

SECTION 10 FENDER AND BUMPER EXTENSIONS

SECTION INDEX

	Page		Page
Bumper Extensions	10-1	Fender Extensions	10-2
Fender Extension Protectors	10-2		

BUMPER EXTENSIONS

GENERAL

The bumper extensions are made of stamped steel and painted black to match the original bumper. The bumper extensions are attached to the front bumper with four bolts.

INSTALLATION—CJ MODELS

- (1) Locate, centerpunch and drill four 25/64-inch holes at marked location as shown in figure 10-1.
- (2) Position bumper extensions on front bumper and install attaching bolts and nuts.
- (3) Tighten nuts to 18 foot-pounds (24 N•m) torque.

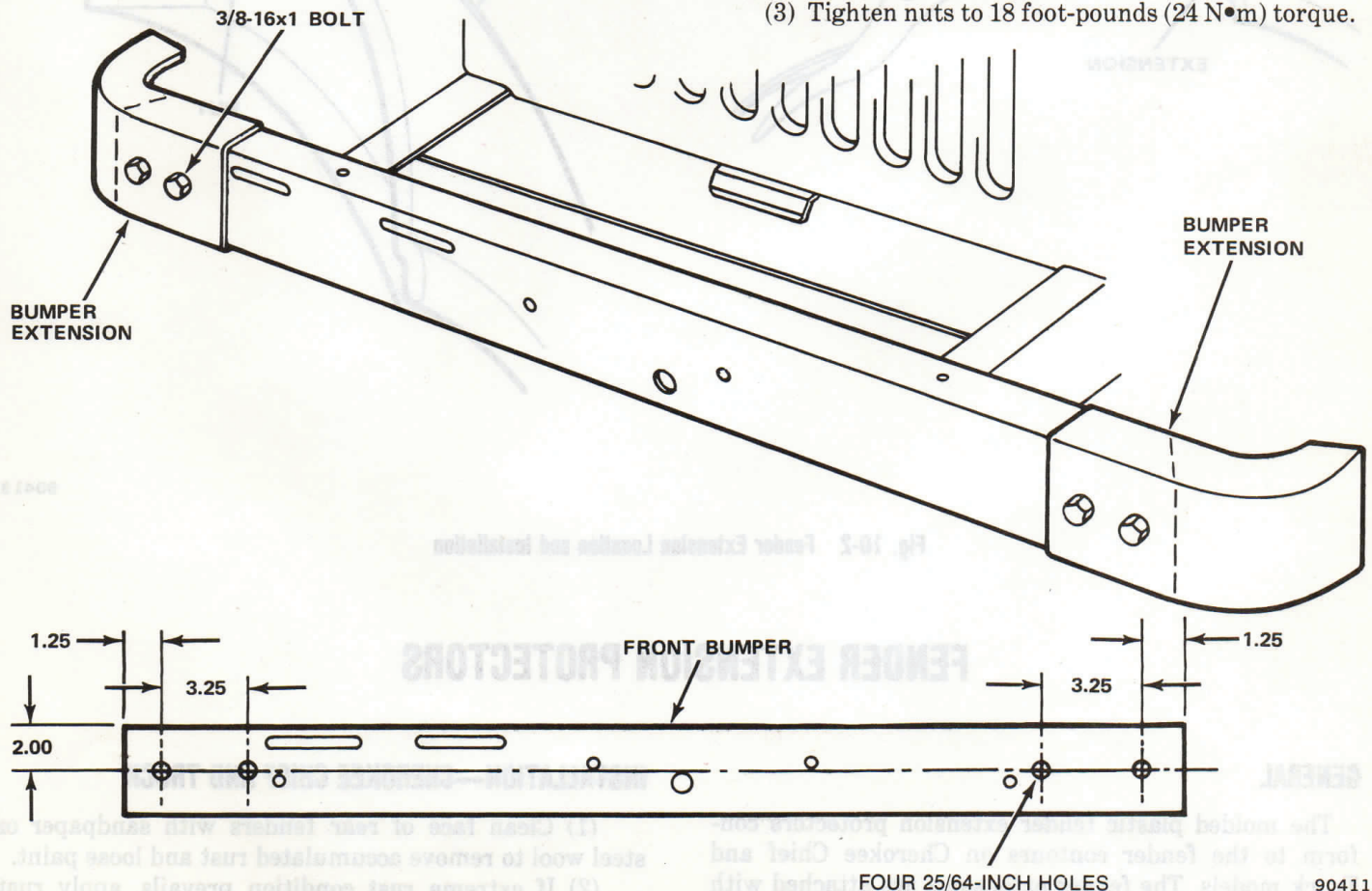

Fig. 10-1 Bumper Extension Location and Installation (Inches)

FENDER EXTENSIONS

GENERAL

The plastic fender extensions are attached to the front and rear CJ fenders with washer head screws and special plastic nuts. The fender extensions protect the body side panels from flying debris.

INSTALLATION—CJ MODELS

(1) Position the respective fender extension into the wheel opening and clamp in place as shown in figure 10-2.

(2) Use fender extension as a template, mark locations of attaching holes.

(3) Remove fender extension.

(4) Centerpunch and drill seven 7/32-inch holes at marked locations.

(5) Position fender extension into wheel opening and install attaching screws and special plastic nuts.

(6) Repeat above procedure on remaining wheel openings.

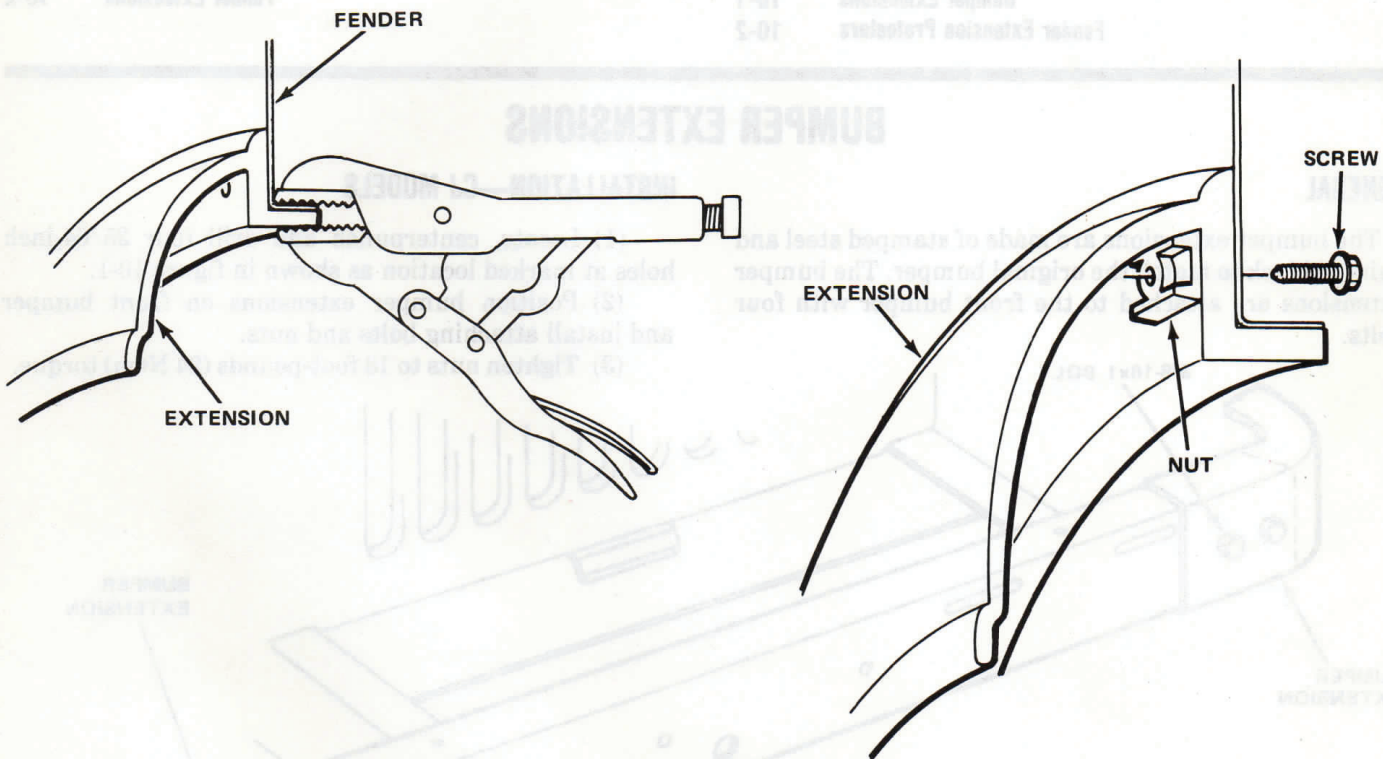

90413

Fig. 10-2 Fender Extension Location and Installation

FENDER EXTENSION PROTECTORS

GENERAL

The molded plastic fender extension protectors conform to the fender contours on Cherokee Chief and Truck models. The fender extensions are attached with adhesive and five screws.

INSTALLATION—CHEROKEE CHIEF AND TRUCK

(1) Clean face of rear fenders with sandpaper or steel wool to remove accumulated rust and loose paint.

(2) If extreme rust condition prevails, apply rust preventive preparation.

(3) Use fender extension protector as a template, mark locations of attaching holes.

(4) Centerpunch and drill five $7/64$ -inch holes at marked locations.

(5) Apply liberal coat of 3M Plastic and Emblem Adhesive or equivalent to entire inside surface of fender extension protector.

(6) Position fender extension protector on rear fender as shown in figure 10-3 and install attaching screws.

(7) Repeat above procedures on other side of vehicle.

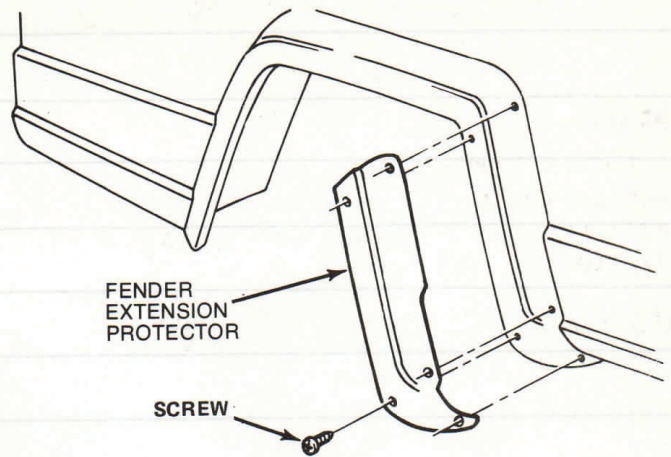

90371

Fig. 10-3 Fender Extension Protector Location and Installation