

SPECIAL INFORMATION

The Engine Build Code Number, the Vehicle Identification Number and the information provided on the Trim Plate are often necessary when determining the proper replacement parts for your vehicle. For their location refer to the General Information Section found at the front of this catalog.

NOTES

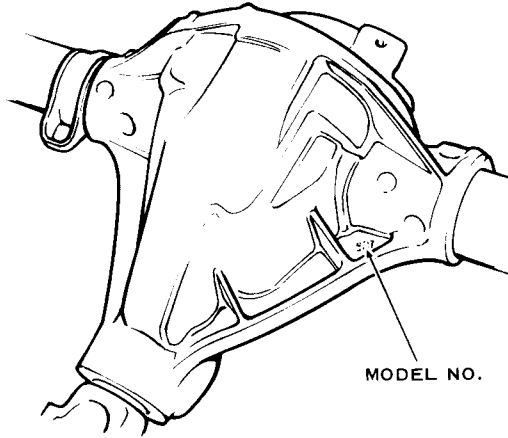

AXLE MODEL IDENTIFICATION

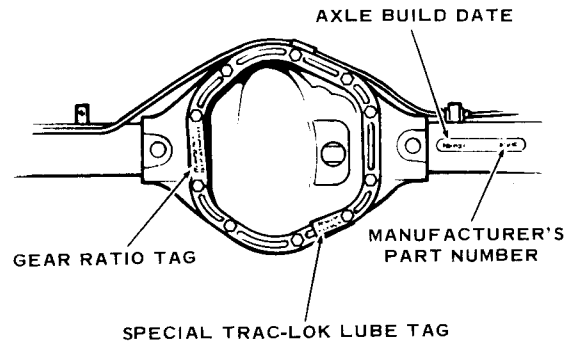

RATIO AND TRAC-LOK DIFFERENTIAL IDENTIFICATION

- 9-1 ..... Used with Axle Tag No. 535 2100, 535 2101, 535 2390, 535 2391 and 535 2572.
- 9-2 ..... Used with Axle Tag No. 535 2464 and 535 2900.
- 9-3 ..... Used with Propeller Shaft Type 1. See Illustration below.
- 9-4 ..... Used with Propeller Shaft Type 2. See Illustration below.

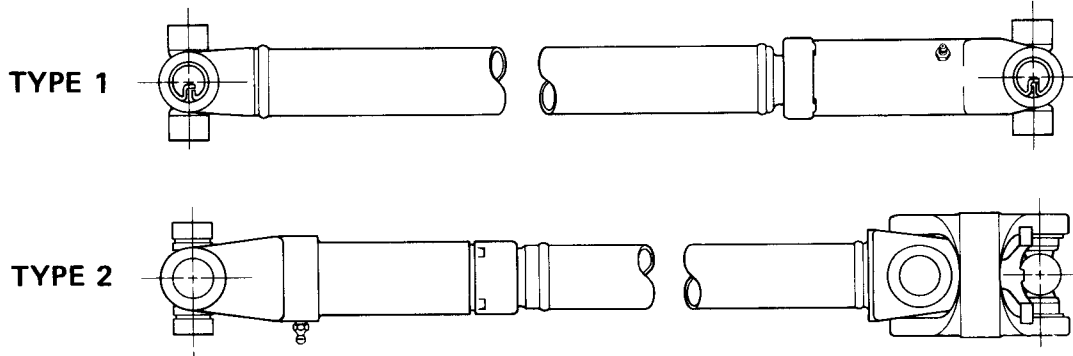



# AXLE - PROPELLER SHAFTS

9.001

GROUP NO. — DESCRIPTION — YEAR and MODEL	PAKS CODE	PRIMARY GROUP NO.	PER CAR	PART NO.	CODE
<b>9.001-1 AXLE ASSEMBLY, Differential Rear (LLD)(Less Shaft)</b>					
<b>MODEL 20 - STANDARD (Tapered Shaft)</b>					
76 80-90 (LQT-3:54 Ratio).....			1	812 7076	
76 80-90 (WQT-3:54 Ratio).....			1	812 7080	
76 80-90 (LQT-4:10 Ratio).....			1	812 7084	
76 90 (WQT-4:10 Ratio).....			1	812 7090	
<b>MODEL 44 - STANDARD</b>					
74 (5352111) 10 (LQT-3:07 Ratio).....			1	812 4002	
74 (5352112) 10 (WQT-3:07 Ratio).....			1	812 4003	
76 (5355294) 10 (WMT-3:07 Ratio).....			1	812 6466	
76 (5356014) 10 (WMT-3:07 Ratio).....			1	812 6466	
76 (5355291) 10 (WHT-3:07 Ratio).....			1	812 6421	
76 (5356008) 10 (WHT-3:07 Ratio).....			1	812 6421	
74 (5352110) 10 (LQT-3:54 Ratio).....			1	812 4000	
74 (5352111) 10 (WQT-3:54 Ratio).....			1	812 4004	
76 (5355296) 10 (WMT-3:54 Ratio).....			1	812 6469	
76 (5356019) 10 (WMT-3:54 Ratio-Cherokee Chief).....			1	812 6464	
76 (5355443) 10 (WMT-3:54 Ratio-Cherokee Chief).....			1	812 6464	
76 (5355292) 10 (WHT-3:54 Ratio).....			1	812 6422	
76 (5356009) 10 (WHT-3:54 Ratio).....			1	812 6422	
76 (5355444) 10 (WHT-3:54 Ratio-Cherokee Chief).....			1	812 6462	
76 (5356011) 10 (WHT-3:54 Ratio-Cherokee Chief).....			1	812 6462	
74 (5352465) 10 (4:09 Ratio).....			1	812 4001	
76 (5355298) 10 (WMT-4:09 Ratio).....			1	812 6471	
76 (5356018) 10 (WMT-4:09 Ratio).....			1	812 6471	
76 (5355293) 10 (WHT-4:09 Ratio).....			1	812 6401	
76 (5356010) 10 (WHT-4:09 Ratio).....			1	812 6401	
76 (5356016) 10 (WMT-5:54 Ratio).....			1	812 6469	
74 (5352106) 25-45 (3:54 Ratio).....			1	812 3499	
76 (5355968) 25-45 (3:54 Ratio).....			1	812 7096	
76 (5356050) 25-45 (3:54 Ratio).....			1	812 7096	
76 (5355429) 25-45 (3:54 Ratio).....			1	812 6472	
76 (5355430) 25-45 (3:54 Ratio).....			1	812 6490	
74 (5352107) 25-45 (4:09 Ratio).....			1	812 4005	
76 (5355970) 25-45 (4:09 Ratio).....			1	812 7099	
76 (5356052) 25-45 (4:09 Ratio).....			1	812 7099	
76 (5355431) 25-45 (4:09 Ratio).....			1	812 6491	
74/75 (5352413) 80 (3:73 Ratio).....			1	812 5055	
74/75 (5352414) 80 (4:27 Ratio).....			1	812 5088	
75 (5354101) 10 (WMT-3:54 Ratio).....			1	812 5452	
75 (5354102) 10 (WMT-4:09 Ratio).....			1	812 5455	
75 (5354103) 10 (WMT-3:07 Ratio).....			1	812 5456	
75 (5354105) 10 (WHT-3:54 Ratio).....			1	812 5457	
75 (5354104) 10 (WHT-3:07 Ratio).....			1	812 5467	
75 (5354692) 10 (WHT-3:54 Ratio).....			1	812 6127	
75 (5353957) 10 (WHT-4:09 Ratio).....			1	812 5486	
75 (5354476) 25-45 (3:54 Ratio).....			1	812 5770	
75 (5354478) 25-45 (4:09 Ratio).....			1	812 5768	
<b>MODEL 60-3 - STANDARD</b>					
74/ (5352102) 26-46 (4:10 Ratio).....			1	812 4647	
74 (5352104) 26-46 (4:88 Ratio).....			1	812 4648	
74/ (5352988) 26-46 (3:73 Ratio).....			1	812 5025	
<b>9.001-2 AXLE, Locking Differential Rear (WLD)(Less Shafts)</b>					
<b>MODEL 20 - TRAC-LOK</b>					
76 80-90 (LQT).....			1	812 7083	
76 80-90 (4:10 Ratio).....			1	812 7091	

AXLE - PROPELLER SHAFTS

**MODEL 44 - TRAC-LOK**

74	(5352556) 10 (3:07 Ratio) .....	1	812 4339
75	(5354107) 10 (3:07 Ratio) .....	1	812 5487
76	(5355295) 10 (WMT-3:07 Ratio) .....	1	812 6468
76	(5356015) 10 (WMT-3:07 Ratio) .....	1	812 6468
74	(5352557) 10 (3:54 Ratio) .....	1	812 4347
75	(5354108) 10 (3:54 Ratio) .....	1	812 5488
76	(5355297) 10 (WMT-3:54 Ratio) .....	1	812 6470
76	(5356017) 10 (WMT-3:54 Ratio) .....	1	812 6470
74	(5352555) 10 (4:09 Ratio) .....	1	812 4338
74	(5352578) 25-45 (3:54 Ratio) .....	1	812 4433
76	(5355969) 25-45 (3:54 Ratio) .....	1	812 7098
76	(5356051) 25-45 (3:54 Ratio) .....	1	812 7098
76	(5355430) 25-45 (3:54 Ratio) .....	1	812 6490
75	(5354477) 25-45 (3:73 Ratio) .....	1	812 5771
74	(5352577) 25-45 (4:09 Ratio) .....	1	812 4416
75	(5354479) 25-45 (4:09 Ratio) .....	1	812 5772
76	(5355971) 25-45 (4:09 Ratio) .....	1	812 7097
76	(5356053) 25-45 (4:09 Ratio) .....	1	812 7097
76	(5355432) 25-45 (4:09 Ratio) .....	1	812 6492
74/75	(5352419) 80 (3:73 Ratio) .....	1	812 5089
74/75	(5352420) 80 (4:27 Ratio) .....	1	812 5087

**MODEL 60-3 - TRAC-LOK**

74/	(5352989) 46 (3:73 Ratio) .....	1	812 4781
74/	(5352566) 46 (4:10 Ratio) .....	1	812 4651
75	(5352566) 46 (4:10 Ratio) .....	1	812 4651
74/	(5352565) 46 (4:88 Ratio) .....	1	812 4649

**9.001-3 BREATHER, Rear Axle**

74/	.....	1	535 2955
-----	-------	---	----------

**9.001-4 HOSE, Rear Axle Breather**

74/	.....	1	535 3097
-----	-------	---	----------

**9.001-5 ATTACHING PARTS, Hose Breather To Body**

BOLT, Hexagon	74/	10.339	1	400 3915
CLAMP, Hose	74/75	17.108	1	G272844
CLAMP, Hose	76		1	322 7851
STRAP, Wirina	74/	3.196	1	318 1008
CLIP, Closed	74/	17.134	1	G140780
NUT, Lock	74	3.303	1	400 1457
NUT, Lock	75/	17.412	1	G271184
NUT, Hexagon	76 80-90	17.410	1	G124824

**9.003-1 HOUSING, Rear Axle (Incl. Tubes)**

74	10 (LQT) .....	1	812 4079
74	10 (WQT) .....	1	812 4007
75	10 (WMT-Except Cherokee Chief) .....	1	812 5453
76	10 (WMT-Except Cherokee Chief) .....	1	812 6467
75	10 (WMT-Cherokee Chief) .....	1	812 6201
76	10 (WMT-Cherokee Chief) .....	1	812 6465
75	10 (WHT-Except Cherokee Chief) .....	1	812 5464
76	10 (WHT-Except Cherokee Chief) .....	1	812 6884
75	10 (WHT-Cherokee Chief) .....	1	812 6200
76	10 (WHT-Cherokee Chief) .....	1	812 6463
74	25-45 .....	1	812 4036
75	25-45 .....	1	812 5769
76	25-45 .....	1	812 7223
74/	26-46 .....	1	812 4020
74/75	80 .....	1	812 5054
76	80-90 (LQT) .....	1	812 7065
76	80-90 (WQT) .....	1	812 7082

**9.003-2 VENT, Rear Axle Tube To Breather Hose**

74/	10 .....	1	535 3494
74/	20-40-80-90 .....	1	535 3495

## AXLE - PROPELLER SHAFTS

9.021

9.004-1	<b>BUMPER, Rear Axle Housing</b> 74/75 ..... (Use 535 3461) .....	1	535 2468
9.004-2	<b>ATTACHING PARTS, Bumper To Bracket Or Floor</b> NUT, Hexagon ..... 74/ (3/8"-16) ..... NUT, Hexagon ..... 74/ (5/16"-18) .....	17.412 17.412	2 G171190 2 G271184
9.005-1	<b>PLUG, Rear Axle Filler</b> 74/ ... (3/4"-16) ..... 76 80-90... (1/2"-14) .....	17.486	1 G103869 1 400 4751
9.007-1	<b>COVER, Rear Axle Housing</b>  <b>LESS GASKET</b> 76 80-90 .....  <b>INCL. GASKET</b> 74 10 (LQT) ..... 74 10 (WQT) ..... 75/ 10 (WMT) ..... 75/ 10 (WHT) ..... 74/ 25-45 ..... 74/ 26-46 ..... 74/75 80 .....	1	321 5943  1 812 4082 1 812 4053 1 812 4082 1 812 4053 1 812 4053 1 812 4025 1 812 4082
9.007-2	<b>ATTACHING PARTS, Cover To Housing</b> BOLT, Hexagon ..... 74/ 10-25-45 ..... BOLT, Hexagon ..... 74/ 26-46 ..... BOLT, Hexagon ..... 74/75 80 ..... BOLT, Hexagon ..... 76 80-90 ..... WASHER, Plain ..... 74/ .....	10 10 10 12 2	991 546 991 106 991 546 400 0722 991 547
9.007-4	<b>GASKET, Rear Axle Housing Cover</b> 74/ 10-25-45-80 ..... 74/ 26-46 ..... 74/75 80 ..... 76 80-90 .....	1 1 1 1	812 2409 943 673 812 2409 317 2122
9.018-1	<b>SCREW, Rear Axle Differential Side Bearing Cap</b> 74/ .....	17.038	4 G179890
9.021-1	<b>CASE ASSEMBLY, Rear Axle Differential (LLD)(Standard)</b> 74/ 10-25-45 (3:07 Ratio) ..... 189 ..... 74/ 10-25-45 (3:54 Ratio) ..... 189 ..... 74/ 10-25-45 (4:09 Ratio) ..... 74/ 26-46 ..... 74/75 80 (3:73) ..... 189 ..... 74 80 (4:10 Ratio) ..... 74/75 80 (4:27 Ratio) ..... 76 80-90 .....	1 1 1 1 1 1 1 1	812 4038 812 4038 812 4077 812 4022 812 4038 812 7069 812 4077 319 1373
9.021-2	<b>CASE ASSEMBLY, Rear Axle Differential (WLD)</b>  <b>MODEL 20 - TRAC-LOK</b> 76 80-90 .....  <b>MODEL 44 - TRAC-LOK</b> 74/ 10-25-45 (3:07 Ratio) ..... 190 ..... 74/ 10-25-45 (3:54 Ratio) ..... 190 ..... 74/ 10-25-45 (4:09 Ratio) ..... 74/ 26-46 ..... 9.024 74 80 (3:73 Ratio) ..... 75 80 (3:73 Ratio) ..... 190 74 80 (4:27 Ratio) ..... 75 80 (4:27 Ratio) .....  <b>MODEL 60-3 - TRAC-LOK</b> 74/ .....	1	812 0235  1 812 4423 1 812 4423 1 812 4413 1 812 4066 1 994 341 1 812 4423 1 994 340 1 812 4413  1 812 4444

9.024

AXLE - PROPELLER SHAFTS

<b>9.024-1</b>	<b>CASE, Rear Axle Differential (LLD)(Standard)</b>			
	74/ 10-25-40 (3:07 Ratio) .....	191	1	812 4039
	74/ 10-25-40 (3:54 Ratio) .....	191	1	812 4039
	76 10-20 (4:09 Ratio).....		1	812 4078
	74/ 26-46 .....		1	812 4023
	76 80-90.....		1	321 2051
	74/75 80 (3:73 Ratio).....	191	1	812 4039
	74/75 80 (4:27 Ratio).....		1	812 4078
<b>9.024-2</b>	<b>CASE, Rear Axle Differential (WLD)</b>			
	<b>MODEL 20 - TRAC-LOK (Case Only)</b>			
	76 80-90.....		1	812 0280
	<b>MODEL 44 - TRAC-LOK (Case Only)</b>			
	74 80 (3:73 Ratio).....		1	994 343
	75 80 (3:73 Ratio).....		1	812 4423
	74 80 (4:27 Ratio).....		1	994 342
	75 80 (4:27 Ratio).....		1	812 4414
	<b>MODEL 44 - TRAC-LOK (Incl. Gasket And Shim Set)</b>			
	74/ 10-25-45 (4:09 Ratio).....		1	812 4414
	74/ 10-25-45 (3:07 Ratio).....		1	812 4424
	74/ 10-25-45 (3:54 Ratio).....		1	812 4424
	<b>MODEL 60-3 - TRAC-LOK</b>			
	74/ 26-46 (4:10 Ratio).....		1	812 6075
	74/ 26-46 (4:88 Ratio).....		1	812 4445
<b>9.027-1</b>	<b>GEAR SET, Rear Axle Differential Side (LLD)(Standard)</b>			
	74/ 10-25-45.....		1	812 4045
	74/ 26-46.....		1	812 4024
	74/75 80.....		1	812 4045
	76 80-90.....		1	812 7092
<b>9.027-2</b>	<b>GEAR SET, Rear Axle Differential Side (WLD)(Trac-Lok)</b>			
	74/ (Model 44)...(Less Gasket And Shims).....		1	994 344
	74/ (Model 44) 10-20...(Incl. Gasket And Shims).....		1	812 4415
	74/ (Model 60-3)...(Incl. Gasket And Shims).....		1	812 4446
	74/75 80...(Less Gasket And Shims).....		1	994 344
	74/75 80...(Incl. Gasket And Shims).....		1	812 4415
	76 80-90.....		2	812 0326
<b>9.027-3</b>	<b>GEAR, Rear Axle Differential Side (LLD)</b>			
	76 80-90.....		2	322 6991
<b>9.029-1</b>	<b>WASHER, Rear Axle Differential Side Gear Thrust (LLD)(Standard)</b>			
	74/75 (Model 44).....		2	805 325
	76 (Model 44) 10-20-40.....		2	805 325
	76 (Model 20) 80-90.....		2	322 0250
<b>9.031</b>	<b>GEAR, Rear Axle Differential Pinion (LLD)</b>			
	76 80-90.....		2	322 1291
<b>9.033-1</b>	<b>WASHER, Rear Axle Differential Pinion Thrust (LLD)(Standard)</b>			
	74/75 (Model 44).....	9.333	2	645 790
	76 (Model 44) 10-20-40.....		2	645 790
	76 (Model 20) 80-90.....		2	322 2999
<b>9.035-2</b>	<b>DISC KIT, Rear Axle Differential Clutch Friction (Incl. Plates)(WLD)(Trac-Lok)</b>			
	74/ 10-25-45.....		1	994 345
	74/ 26-46.....		1	812 2379
	74/75 80.....		1	994 345
	76 80-90.....		1	812 0325
<b>9.036-1</b>	<b>SHAFT, Rear Axle Differential (LLD)(Standard)</b>			
	74/75 (Model 44).....	9.336	1	805 327
	76 (Model 44) 10-20-40.....		1	805 327
	76 (Model 20) 80-90.....		1	321 8195

## AXLE - PROPELLER SHAFTS

9.050

<b>9.036-3</b>	<b>PIN, Rear Axle Differential Shaft (LLD)(Standard)</b>			
	74/ (Model 44) .....	1	636	360
	76 (Model 20) 80-90 .....	17.472	1	G455313
<b>9.039-1</b>	<b>BLOCK, Rear Axle Differential Pinion Shaft Thrust (LLD)</b>			
	76 80-90 .....		1	316 2323
<b>9.040</b>	<b>RING, Rear Axle Differential Pinion And Shaft Snap (WLD)</b>			
	76 80-90 .....		2	812 1787
<b>9.041-1</b>	<b>BEARING, Rear Axle Differential Side</b>			
	74/75 80 .....	9.341	2	805 311
	76 80-90 (Cup) .....	9.043	2	317 2566
	76 80-90 (Bearing) .....		2	317 2565
<b>9.044-1</b>	<b>BEARING KIT, Rear Axle Differential</b>			
	74/ 10-25-45 .....	9.041	1	812 4071
	74/ 26-46 .....	9.052	1	812 4028
	74/75 80 .....		1	812 4071
<b>9.045-1</b>	<b>SHIM SET, Rear Axle Differential Side Bearing</b>			
	74/ 10-25-45 .....		1	812 6237
	74/ 26-46 .....		1	919 619
	74/75 80 .....	9.345	1	806 483
<b>9.045-2</b>	<b>SHIM SET KIT, Rear Axle Differential Side Bearing</b>			
	74/ (Model 60-3) .....		1	812 4784
	74/ (Model 44) .....	9.345	1	812 4791
	76 80-90 .....		1	320 5532
<b>9.045-3</b>	<b>SHIMS, Rear Axle Differential Side Bearing</b>			
	76 (.080 Thick) .. 80-90 .....		1	320 5512
	76 (.082 Thick) .. 80-90 .....		1	320 5513
	76 (.084 Thick) .. 80-90 .....		1	320 5514
	76 (.086 Thick) .. 80-90 .....		1	320 5515
	76 (.088 Thick) .. 80-90 .....		1	320 5516
	76 (.090 Thick) .. 80-90 .....		1	320 5517
	76 (.092 Thick) .. 80-90 .....		1	320 5518
	76 (.094 Thick) .. 80-90 .....		1	320 5519
	76 (.096 Thick) .. 80-90 .....		1	320 5520
	76 (.098 Thick) .. 80-90 .....		1	320 5521
	76 (.100 Thick) .. 80-90 .....		1	320 5522
	76 (.102 Thick) .. 80-90 .....		1	320 5523
	76 (.104 Thick) .. 80-90 .....		1	320 5524
	76 (.106 Thick) .. 80-90 .....		1	320 5525
	76 (.108 Thick) .. 80-90 .....		1	320 5526
	76 (.110 Thick) .. 80-90 .....		1	320 5527
<b>9.050-1</b>	<b>GEAR SET, Rear Axle Ring</b>			
	<b>(Incl. Bearings, Seals, Gasket And Shims)</b>			
	74/ 10 (3:07 Ratio) .....		1	812 4083
	74/ 10-25-45 (3:54 Ratio) .....	185	1	812 4037
	74/ 10-25-45 (4:09 Ratio) .....		1	812 4076
	74/ 26-46 (4:10 Ratio) .....		1	812 4021
	74/ 26-46 (4:88 Ratio) .....		1	812 4776
	74/ 46 (3:73 Ratio) .....		1	812 4782
	74/75 80 (3:73 Ratio) .....		1	812 4777
	74/75 80 (4:27 Ratio) .....		1	812 5051
	<b>(Less Bearings, Seals, Gasket And Shims)</b>			
	76 80-90 (3:54 Ratio) .....		1	448 6825
	76 80-90 (4:10 Ratio) .....		1	812 7072
<b>9.050-2</b>	<b>ATTACHING PARTS, Ring Gear To Differential Case</b>			
	SCREW, Machine .....	76 (Model 20) 80-90 .....	1	448 6828
	SCREW, Machine .....	74/75 (Model 44) .....	9.350	10 649 454
	SCREW, Machine .....	76 (Model 44) 10-20-40 .....	9.350	10 649 454
	SCREW, Machine .....	74/ (Model 60-3) .....		12 919 586

9.050

AXLE - PROPELLER SHAFTS

<b>9.050-4</b>	<b>NUT, Rear Axle Pinion</b>			
	76 (Model 20) 80-90.....	.....	1	318 2601
	76 (Model 44) 10-20-40.....	.....	1	801 367
	74/75 (Model 44).....	9.380	1	801 367
	74/ (Model 60).....	.....	1	919 585
<b>9.050-5</b>	<b>WASHER, Rear Axle Pinion Nut</b>			
	74/.....	9.380	1	636 570
<b>9.052-1</b>	<b>BEARING, Rear Axle Pinion (Front)</b>			
	74/75 80.....	.....	1	52 878
	76 80-90.....	.....	1	317 2135
<b>9.052-2</b>	<b>BEARING, Rear Axle Pinion (Rear)</b>			
	74/75 80.....	.....	1	807 266
	76 80-90.....	.....	1	317 2563
<b>9.055-1</b>	<b>CUP, Rear Axle Pinion Bearing (Front)</b>			
	74/75 80.....	.....	1	52 879
	76 80-90.....	.....	1	317 2134
<b>9.055-2</b>	<b>CUP, Rear Axle Pinion Bearing (Rear)</b>			
	74/75 80.....	.....	1	52 877
	76 80-90.....	.....	1	317 2564
<b>9.055-3</b>	<b>BEARING KIT, Rear Axle Pinion Inner</b>			
	74/ 10-25-45.....	9.052	1	812 4051
	74/ 26-46.....	9.052	1	812 4026
	74/75 80.....	9.052	1	812 4051
<b>9.055-4</b>	<b>BEARING KIT, Rear Axle Pinion Outer</b>			
	74/ 10-25-45..... 180	9.052	1	812 4052
	74/ 26-46.....	9.052	1	812 4027
	74/75 80.....	9.052	1	812 4052
<b>9.056-1</b>	<b>SPACER, Rear Axle Pinion</b>			
	76 80-90.....	.....	1	318 5971
<b>9.057-1</b>	<b>SHIM SET, Rear Axle Pinion Adjusting</b>			
	74/75 10-25-45.....	9.050	1	812 4588
	76 10-20.....	.....	1	812 5924
	74/ 26-46.....	.....	1	945 709
	74/75 80.....	9.357	1	649 228
	76 (.093 Thick)...80-90.....	.....	1	320 5533
	76 (.094 Thick)...80-90.....	.....	1	320 5534
	76 (.095 Thick)...80-90.....	.....	1	320 5535
	76 (.096 Thick)...80-90.....	.....	1	320 5536
	76 (.098 Thick)...80-90.....	.....	1	320 5537
<b>9.064-1</b>	<b>OIL SEAL, Rear Axle Pinion Bearing</b>			
	76 (Model 20) 80-90.....	.....	1	320 8474
	74/ (Model 44) 10-20-40.....	9.364	1	998 092
	75 (Model 44) 80.....	.....	1	998 092
	74/ (Model 60).....	.....	1	998 123
<b>9.064-3</b>	<b>SLINGER, Rear Axle Pinion Bearing Oil</b>			
	74/ (Model 44).....	9.364	1	908 301
	74/ (Model 60-3).....	.....	1	919 608
<b>9.068-1</b>	<b>SHAFT, Rear Axle Drive</b>			
	<b>LEFT</b>			
	74 10 (LQT).....	.....	1	812 4081
	74 10 (WQT).....	.....	1	812 4085
	75/ 10 (WMT).....	.....	1	812 4081
	75/ 10 (WHT-Except Cherokee Chief).....	.....	1	812 4034



## AXLE - PROPELLER SHAFTS

9.100

	75/	10 (WHT-Cherokee Chief) .....	1	812 4034
	74/	25-45. ....	1	812 4034
	74/	26-46 (LLD). ....	1	812 4030
	76	26-46 (WLD). ....	1	812 4448
	74/75	80 .....	1	812 4778
	76	80-90 (LQT). ....	1	812 7070
	76	80-90 (WQT). ....	1	812 7079
	<b>RIGHT</b>			
	74	10 (LQT). ....	1	812 4080
	74	10 (WQT). ....	1	812 4084
	75/	10 (WMT) .....	1	812 4080
	75/	10 (WHT-Except Cherokee Chief). ....	1	812 4084
	75/	10 (WHT-Cherokee Chief) .....	1	812 4080
	74/75	25-45. ....	1	812 4035
	76	25-45. ....	1	812 7224
	74/	26-46 (LLD). ....	1	812 4029
	74/75	80. ....	1	812 4778
	76	26-46 (WLD). ....	1	812 4447
	76	80-90 (LQT). ....	1	812 7071
	76	80-90 (WQT). ....	1	812 7081
<b>9.072-1</b>	<b>SEAL, Rear Axle Drive Shaft Inner Oil</b>			
	74/	10-25-45. ....	2	994 258
	74/75	80. ....	2	994 258
	76	80-90. ....	2	317 0700
<b>9.072-2</b>	<b>PLUG, Rear Axle Shaft Flange</b>			
	74/	(Model 44) .....	1	994 259
<b>9.086-1</b>	<b>BUMPER, Rear Axle</b>			
	74/75	10-20-40 .....	2	933 689
	74/75	80-90 .....	2	945 577
	76	.....	2	535 5483
<b>9.086-2</b>	<b>ATTACHING PARTS, Rear Axle Bumper To Frame</b>			
	BOLT, Hexagon	74/75 80. ....	17.038	4 G180079
	SCREW, Hexagon	76 .....	10.350	4 400 5063
	NUT, Hexagon	74/ .....	17.412	4 G271184
<b>9.100-1</b>	<b>SHAFT ASSEMBLY, Propeller (Complete)(Collapsed Length Is Front Center Of End Yoke)</b>			
	<b>FRONT</b>			
	74/75	10-20-40 (W3ST) .....	1	535 2117
	76	10-20-40 (W3ST-Six) .....	1	535 4818
	76	10-20-40 (W3ST-V8). ....	1	535 2117
	74/75	10-20-40 (W4ST) .....	1	535 2118
	76	10-20-40 (W4ST) .....	1	535 2118
	74/75	10-20-45 (WHT-Six) .....	1	535 2119
	76	10-20-40 (WAT-Six) .....	1	535 2119
	74/75	10-20-40 (WHT-V8) .....	1	535 2118
	76	10-20-40 (WAT-V8) .....	1	535 2118
	74/75	46 (WHT-Six) .....	1	535 2118
	74/75	80 (W3ST) .....	1	535 1013
	76	80-90 (W3ST) .....	1	535 4457
	74/75	80 (W4ST) .....	1	535 1014
	76	80-90 (W4ST) .....	1	535 3242
	76	90 (WAT). ....	1	535 5573
	<b>REAR</b>			
	74/	10 (W3ST) .....	1	947 562
	76	10 (Six-W3ST) .....	1	535 4817
	74/	10 (W4ST) .....	1	992 323
	74	10 (Six-WHT) .....	1	535 2126
	75	10 (Six-WHT) .....	1	535 2667
	76	10 (Six-WAT) .....	1	535 2667

9.100

AXLE - PROPELLER SHAFTS

74	10 (V8-WHT-WQT)	.....	1	535 2127
75	10 (V8-WHT)	.....	1	535 3633
76	10 (V8-W3ST)	.....	1	947 592
76	10 (V8-W4ST)	.....	1	992 323
76	10 (V8-WAT)	.....	1	535 3633
74/75	25 (LHD-W3ST)	.....	1	535 1027
76	25 (Six-W3ST)	.....	1	535 3638
<b>74</b>	<b>25 (RHD-W3ST)</b>	.....	1	535 1029
74/75	25 (W4ST)	.....	1	535 1944
76	25 (W4ST)	.....	1	535 1944
74	25 (Six-WHT)	.....	1	535 2120
75	25 (Six-WHT)	.....	1	535 2668
76	25 (Six-WAT)	.....	1	535 2668
76	25 (V8-W3ST)	.....	1	535 1027
75	25 (V8-WHT)	.....	1	535 3645
74	25 (V8-WHT-LQT)	.....	1	535 1944
74	25 (V8-WHT-WQT)	.....	1	535 1031
76	25 (V8-WAT)	.....	1	535 3645
74	26 (Six-W3ST)	.....	1	535 2690
76	26 (Six-W3ST)	.....	1	535 1031
74/75	26 (W4ST)	.....	1	535 1031
76	40 (Six-WAT)	.....	1	535 1037
74	40 (V8-WHT-WQT)	.....	1	535 1036
75	45 (V8-WHT)	.....	1	535 1054
74/75	45 (W3ST)	.....	1	535 1039
76	45 (Six-W3ST)	.....	1	535 1038
74/75	45 (W4ST)	.....	1	535 1040
76	45 (W4ST)	.....	1	535 1040
74	45 (Six-WHT)	.....	1	535 2114
75	45 (Six-WHT)	.....	1	535 1037
76	45 (V8-W3ST)	.....	1	535 1039
75	45 (V8-WHT)	.....	1	535 1054
76	45 (V8-WHT)	.....	1	535 6064
74	46 (Six-W3ST)	.....	1	535 1035
74/75	46 (V8-W3ST)	.....	1	535 1038
76	46 (V8-W3ST)	.....	1	535 1038
74/75	46 (W4ST)	.....	1	535 1036
74	46 (WHT-WQT)	.....	1	535 1054
75	46 (V8-WHT)	.....	1	535 1054
76	46 (V8-WHT)	.....	1	535 6184
74/75	80 (W4ST)	.....	1	535 1020
76	83 (W4ST-Six)	.....	1	535 5757
74/75	83 (W3ST)	.....	1	535 1021
76	83 (W3ST)	.....	1	535 5754
74/75	84 (W3ST)	.....	1	535 1022
76	84 (W3ST)	.....	1	535 5755
76	90 (W3ST)	.....	1	535 5756
76	90 (W4ST)	.....	1	535 5758
76	90 (WAT)	.....	1	535 5759

9.100-2 ATTACHING PARTS, Rear Propeller Shaft To Rear Axle

CLAMP	74/	.....	2	940 034
BOLT, Hexagon	74/	.....	17.038	4 G454847
WASHER, Lock	74/	.....	17.820	4 G120380
NUT, Hexagon	74/	.....	17.406	4 G120368

9.100-3 ATTACHING PARTS, Propeller Shaft To Transfer Case

U-BOLT	74/	.....	2	A 490
WASHER, Lock	74/	.....	17.820	4 G120214
NUT, Hexagon	74/	.....	17.406	4 G120368

9.100-4 ATTACHING PARTS, Propeller Shaft To Yoke (Front And Rear)

U-BOLT	74/	.....	AR	A 490
WASHER, Lock	74/	.....	17.820	AR G120214
NUT, Hexagon	74/	.....	17.406	AR G120368

9.100-5 ATTACHING PARTS, Rear Propeller Shaft To Transfer Case

BOLT, Hexagon	74/	.....	4	630 595
WASHER, Lock	74/	.....	17.820	4 G120382
NUT, Hexagon	74/	.....	17.406	4 G120369

## AXLE - PROPELLER SHAFTS

9.112

<b>9.100-6</b>	<b>ATTACHING PARTS, Propeller Shaft To Front Axle</b>			
	U-BOLT .....	74/ .....	.....	2 A 490
	WASHER, Lock .....	74/ .....	17.820	4 G120214
	NUT, Hexagon .....	74/ .....	17.406	4 G120368
<b>9.104-1</b>	<b>YOKE, Front Propeller Shaft Universal Joint Sleeve</b>			
	74	10 (LQT) .....	.....	1 994 241
	74	10 (WQT) .....	9.404	1 935 685
	75	10 (WMT) .....	.....	1 994 241
	75	10 (WHT) .....	.....	1 932 209
	74/75	25-45 .....	9.404	1 935 685
	74/75	26-46 .....	.....	1 945 711
	74/75	80 .....	9.404	1 935 685
	76	.....	.....	1 932 209
<b>9.104-2</b>	<b>YOKE, Rear Propeller Shaft Universal Joint Sleeve</b>			
	74	10 (WHT-WQT) .....	.....	1 812 7263
	74/	20-80-90 .....	.....	1 932 209
	74/	40 (W4ST)(WHT-LQT) .....	.....	1 932 209
	74/	40 (W3ST) .....	.....	1 812 4812
<b>9.104-3</b>	<b>YOKE, Rear Propeller Shaft Flanged</b>			
	74	(Holes Diaagonal 2-7/8" Apart) ... 10 (WHT) .....	18.115	1 940 471
	74	(Holes Diaagonal 3-1/8" Apart) ... 10 (WHT) .....	.....	1 807 784
	74	(Holes Diagonal 3-1/8" Apart) ... 20-80 .....	.....	1 807 784
<b>9.104-6</b>	<b>YOKE, Axle Pinion</b>			
	76	10 (WMT) .....	.....	1 994 241
	76	10 (WHT) .....	.....	1 935 685
	76	20 .....	.....	1 935 685
	74	(Model 44) .....	9.404	1 935 685
	74/	(Model 60) .....	.....	1 945 711
	75	(Except Cherokee Chief) .....	9.404	1 935 685
	75	(Cherokee Chief) .....	.....	1 812 6202
	76	80-90 .....	.....	1 812 6054
<b>9.107-2</b>	<b>SPIDER ASSEMBLY, Propeller Shaft Universal Joint</b>			
	74/	10 (WMT) .....	.....	2 940 802
	74/	10 (WHT) .....	.....	2 448 5624
	74/	20-40-80-90 (* 9-3) .....	.....	2 448 5624
	76	(Rear) 20-40-80-90 (* 9-4) .....	.....	2 812 7332
	76	(Front) 20-40-80-90 (* 9-4) .....	.....	1 448 5624
<b>9.107-3</b>	<b>SNAP RING, Propeller Shaft Universal Joint</b>			
	74/	10 (WMT) .....	9.113	AR 940 798
	74/	10 (WHT) .....	.....	AR A 945
	74/	20-40-80-90 .....	.....	AR A 945
<b>9.110-1</b>	<b>CAP, Front Propeller Shaft Sleeve Yoke Dust</b>			
	74/	.....	.....	1 A 942
<b>9.110-2</b>	<b>CAP, Rear Propeller Shaft Sleeve Yoke Dust</b>			
	74/	.....	.....	1 A 942
<b>9.110-3</b>	<b>SEAL, Propeller Shaft Sleeve Yoke Dust Cap</b>			
	74/	10 (WHT) .....	.....	1 925 869
	74/	20-80-90 .....	.....	1 925 869
	74/	40 (W3ST) .....	.....	1 812 4813
	74/	40 (W4ST)(WHT) .....	.....	1 925 869
<b>9.110-6</b>	<b>YOKE KIT, Front Propeller Shaft Socket</b>			
	74/	.....	.....	1 994 823
<b>9.112-1</b>	<b>FITTING, Propeller Shaft Lubricating</b>			
	74/	(Straight Type-1/4"-28) .....	17.290	1 G271287
	74/	(Flush Type) .....	.....	1 994 826

9.113

AXLE - PROPELLER SHAFTS

<b>9.113-1</b>	<b>HOUSING, Rear Propeller Shaft Universal Joint</b>			
	74/ 10 (WMT) .....	1		940 794
<b>9.113-2</b>	<b>DUST KIT, Rear Propeller Shaft Cover And Clamp</b>			
	74/ 10 (WMT) .....	1		940 801
<b>9.113-3</b>	<b>JOINT KIT, Rear Propeller Shaft Universal</b>			
	74/ 10 (WMT) .....	1		940 800
<b>9.113-4</b>	<b>CLAMP, Rear Propeller Shaft Body End Dust Cover (Large)</b>			
	74/ 10 (WMT)..... (Use 812 3249) .....	1		940 795
<b>9.113-5</b>	<b>CLAMP, Rear Propeller Shaft Dust Cover (Small)</b>			
	74/ 10 (WMT) .....	1		940 796
<b>9.113-6</b>	<b>COVER, Rear Propeller Shaft Grease Flat</b>			
	74/ 10 (WMT) .....	1		940 793
<b>9.113-7</b>	<b>GASKET, Rear Propeller Shaft Housing Cover</b>			
	74/ 10 (WMT) .....	1		940 799
<b>9.301-1</b>	<b>AXLE ASSEMBLY, Front</b>			
	<b>MODEL 30 (Less Axle Shafts And Knuckle Assembly)</b>			
	76 80-90 (3:54 Ratio).....	1		812 6517
	76 80-90 (4:09 Ratio).....	1		812 6493
	<b>MODEL 30 (Incl. Axle Shafts And Knuckle Assembly)</b>			
	74/75 80 (3:73 Ratio).....	1		535 0863
	74/75 80 (LHD-4:27 Ratio).....	1		535 0864
	<b>74/75 80 (RHD-4:27 Ratio)</b> .....	1		535 0894
	<b>MODEL 44 (Less Shafts And Knuckle Assembly)</b>			
	74/ (5352390) 10 (LDB-3:54 Ratio).....	1		812 4635
	74/ (5352101) 10 (LDB-3:07 Ratio).....	1		812 4636
	74/ (5352900) 10 (LHD-LDB-4:09 Ratio).....	1		812 4633
	<b>74/75 10 (RHD-LDB-4:09 Ratio)</b> .....	1		812 4809
	74/ (5352572) 10 (WDB-4:09 Ratio).....	1		812 4627
	74/ (5352391) 10 (WDB-3:54 Ratio).....	1		812 4632
	74/ (5352100) 10 (WDB-3:07 Ratio).....	1		812 4628
	74/ (5352093) 25-45 (LDB-3:54 Ratio).....	1		812 4640
	74/ (5352095) 25-45 (LDB-4:09 Ratio).....	1		812 4639
	74/ (5352094) 25-45 (WDB-3:54 Ratio).....	1		812 4638
	74/ (5352632) 25-45 (WDB-4:09 Ratio).....	1		812 4637
	74/ (5352696) 26-46 (WDB-4:09 Ratio).....	1		812 4641
	74/ (5352974) 26-46 (3:73 Ratio).....	1		812 5027
	74/ (5352693) 26-46 (LHD-WDB-4:88 Ratio).....	1		812 4643
	<b>74/75 (5352901) 26-46 (RHD-WDB-4:88 Ratio)</b> .....	1		812 4811
	75/ (5355015) 10 (3:54 Ratio-Cherokee Chief) .....	1		812 6126
<b>9.301-2</b>	<b>BREATHER, Front Axle</b>			
	74/ .....	9.001	1	535 2955
<b>9.301-3</b>	<b>HOSE, Front Axle Breather</b>			
	74/ .....	9.001	1	535 3097
<b>9.301-4</b>	<b>ATTACHING PARTS, Hose Breather To Body</b>			
	CLAMP, Hose ..... 74/75 .....	17.108	1	G272844
	CLAMP, Hose ..... 76 .....	4.160	1	322 7851
	STRAP, Wirina ..... 74/75 .....	3.196	1	318 1008
	STRAP, Wirina ..... 76 .....	3.165	1	322 3227
	CLIP, Closed ..... 74/ .....	17.134	1	G140780
<b>9.301-4b</b>	<b>VENT, Front Axle Tube To Breather Hose</b>			
	74/ .....	9.003	1	535 3495

## AXLE - PROPELLER SHAFTS

9.321

<b>9.303-1 HOUSING, Front Axle (Incl. Tubes)</b>			
74/	10 (Except Cherokee Chief).....	1	812 4332
75/	10 (Cherokee Chief) .....	1	812 4642
74/	25-45.....	1	812 4365
74/	26-46 (3:73 Ratio).....	1	812 4642
74/	46 (4:09 Ratio).....	1	812 4365
74/75	80.....	1	812 2175
76	80-90.....	1	812 6501
<b>9.304-1 BUMPER, Front Axle</b>			
74/75	10-20-40.....	2	935 046
74/75	80-90.....	9.086 2	945 577
76	.....	2	535 5483
<b>9.304-2 ATTACHING PARTS, Bumper To Frame</b>			
SCREW, Hexagon .....	74/75 10-20-40... (5/16"-18 x 3/4") .....	17.672 4	G172455
SCREW, Tapping.....	74/75 80 (Six) .....	17.670 4	G172463
SCREW, Tapping.....	74/75 80 (V8) .....	17.670 2	G172463
SCREW, Hexagon .....	76 .....	10.350 4	400 5063
<b>9.304-3 BRACKET, Front Axle Bumper Frame</b>			
74/75	(Upper) 10-20-40.....	1	535 2012
74/75	(Lower) 10-20-40 .....	1	535 2013
76	(Right Side-Antiwindup).....	1	812 6586
<b>9.304-3a BUMPER, Axle Housing Front Windup Pinion</b>			
75	.....	1	535 3461
76	10-20-40.....	1	535 4848
76	80-90.....	1	535 3461
<b>9.304-4 SPACER, Front Axle Bumper Frame Bracket</b>			
74/	80.....	9.086 1	948 072
<b>9.304-4a ATTACHING PARTS, Front Axle Housing To Frame</b>			
SCREW, Hexagon .....	75/ (5/16"-18 x 5/8") .....	10.340 4	400 5063
SPACER .....	76 SIX...(1/4" Thick) .....	1	941 411
SPACER .....	75/ 258...(1/2" Thick) .....	9.086 1	940 304
NUT, Hexagon.....	75/ ... (Incl. Washer) .....	17.412 1	G271190
NUT, Hexagon.....	76 80-90.....	10.260 1	400 3909
NUT, Hexagon.....	76 (3/8" x 16).....	1	448 7549
<b>9.305-1 PLUG, Front Axle Differential Housing Filter</b>			
74/	(Threaded) .....	17.486 1	G103869
76	(Snap In) .....	1	812 7358
<b>9.307-1 COVER, Front Axle Housing</b>			
<b>MODEL 30 (Incl. Plug)</b>			
74/75	80.....	1	812 1386
76	80-90.....	1	812 6498
<b>MODEL 44 (Incl. Gasket Bolts)</b>			
74/	10-20-40.....	1	812 4352
<b>9.307-2 ATTACHING PARTS, Cover To Housing</b>			
BOLT, Hexagon .....	74/ .....	9.007 10	991 546
<b>9.307-3 GASKET, Front Axle Housing Cover</b>			
74/	10-20-40.....	9.007 1	812 2409
74/75	80.....	1	812 0360
76	80-90.....	1	812 2409
<b>9.318-1 SCREW, Front Axle Differential Side Bearing Cap</b>			
74/	.....	17.038 4	G179890
<b>9.321-1 CASE ASSEMBLY, Front Axle Differential</b>			
<b>MODEL 30 (Incl. Side Gears And Thrust Washers)</b>			
74/75	80.....	1	812 3098
76	80-90 (3:54 Ratio).....	1	812 6513
76	80-90 (4:09 Ratio).....	1	812 6495

9.329

AXLE - PROPELLER SHAFTS

**MODEL 44 (Incl. Cover, Gasket And Shim Set)**

74/	(3:07 Ratio) .....	9.021	1	812 4038
74/	(3:54 Ratio) .....	9.021	1	812 4038
74/	(3:73 Ratio) .....	9.021	1	812 4038
74/	(4:09 Ratio) .....	9.021	1	812 4077
74/	(4:88 Ratio) .....	9.021	1	812 4077

**9.324-1 CASE, Front Axle Differential**

**MODEL 30 (Case Only)**

74/75	80.....		1	947 056
76	80-90 (3:54 Ratio).....		1	812 6515
76	80-90 (4:09 Ratio).....		1	812 6496

**MODEL 44 (Incl. Cover, Gasket And Shim Set)**

74/	10 (* 9-1) .....	9.024	1	812 4039
74/	10 (* 9-2) .....	9.024	1	812 4078
74/	25-45 (3:54 Ratio).....	9.024	1	812 4039
74/	20-40 (4:09 Ratio).....	9.024	1	812 4078
74/	26-46 (3:73 Ratio).....	9.024	1	812 4039

**9.327-1 GEAR SET, Front Axle Differential Side**

**MODEL 30**

74/75	80... (Incl. Pinion Shaft And Thrust Washer).....		1	812 0365
74/75	80... (Less Pinion Shaft And Thrust Washer).....		1	812 0364
76	80-90... (Incl. Pinion Shaft And Thrust Washers).....		1	812 6497

**MODEL 44 (Incl. Cover Gasket And Pinion Bolts)**

74/	10-20-40.....	9.027	1	812 4045
-----	---------------	-------	---	----------

**9.329-1 WASHER, Front Axle Differential Side Gear Thrust**

74/	(Model 30).....		2	812 0832
74/	(Model 44).....		2	645 789

**9.333-1 WASHER, Front Axle Differential Pinion Gear Thrust**

74/	(Model 30).....		2	812 0831
74/	(Model 44).....		2	645 790

**9.336-1 SHAFT, Front Axle Differential Pinion Mate**

74/	(Model 30).....	9.327	1	812 0833
74/	(Model 44).....		1	805 327

**9.336-3 PIN, Front Axle Differential Shaft**

74/	.....	9.036	1	636 360
-----	-------	-------	---	---------

**9.341-1 BEARING, Front Axle Differential Side**

**MODEL 30**

74/75	80 (Bearing Only) .....		2	925 446
76	80-90... (Incl. Bearing And Cup).....		1	812 6500

**MODEL 44 (Incl. Bearing And Cup)**

74/	10-20-40.....	9.041	1	812 4071
-----	---------------	-------	---	----------

**9.343-1 CUP, Front Axle Differential Side Gear Bearing**

74/75	80.....	9.043	2	945 341
-------	---------	-------	---	---------

**9.345-1 SHIM SET, Front Axle Differential Side Gear Bearing**

**MODEL 30**

74/75	80.....		1	648 061
76	80-90.....		1	812 6506

**MODEL 44**

74/	.....		1	812 4791
-----	-------	--	---	----------

## AXLE - PROPELLER SHAFTS

9.364

<b>9.350-1</b>	<b>GEAR SET, Front Axle</b>			
	<b>MODEL 30 (Incl. Pinion)</b>			
	76	80-90 (3:54 Ratio).....	1	812 6518
	74/75	80 (3:73 Ratio).....	1	945 345
	76	80-90 (4:09 Ratio).....	1	812 6494
	74/75	80 (4:27 Ratio).....	1	945 346
	<b>MODEL 44 (Incl. Pinion Bearing, Shim Sets, Cover Gasket, Pinion Nut, Washer, Seal And Slinger)</b>			
	74/	(3:07 Ratio).....	1	812 4363
	74/	(3:54 Ratio).....	1	812 4348
	74/	(3:73 Ratio).....	1	812 4777
	74/	(4:09 Ratio).....	1	812 4364
	74/	(4:88 Ratio).....	1	812 4386
<b>9.350-2</b>	<b>ATTACHING PARTS, Ring Gear To Differential Case</b>			
	BOLT, Hexagon	74/.....	10	649 454
<b>9.350-4</b>	<b>NUT, Front Axle Pinion</b>			
	74/	.....	9.380	1 801 367
<b>9.350-5</b>	<b>WASHER, Front Axle Drive Pinion Nut</b>			
	74/	.....	9.380	1 636 570
<b>9.350-6</b>	<b>SHIM SET, Front Axle Pinion</b>			
	74/	10-20-40.....	9.057	1 812 5773
	76	80-90.....	1	812 6503
<b>9.350-7</b>	<b>SHIM SET, Front Axle Differential Pinion</b>			
	74/	10-20-40.....	9.050	1 812 5924
	75	80.....	1	812 5924
	76	80-90.....	1	812 6502
<b>9.352-1</b>	<b>BEARING, Front Axle Pinion (Inner Front)</b>			
	74/75	80..... (Use 315 6066)	1	926 803
<b>9.352-2</b>	<b>BEARING, Front Axle Pinion (Outer Rear)</b>			
	74/75	80.....	1	U 52 878
<b>9.355-1</b>	<b>CUP, Front Axle Pinion Bearing (Inner-Front)</b>			
	74/75	80..... (Use 315 6065)	1	926 805
<b>9.355-2</b>	<b>CUP, Front Axle Pinion Bearing (Outer-Rear)</b>			
	74/75	80.....	1	U 52 879
<b>9.355-3</b>	<b>BEARING, Front Axle Pinion Kit (Inner-Pinion)</b>			
	74/	10-20-40.....	9.052	1 812 4051
	76	80-90.....	1	812 6499
<b>9.355-4</b>	<b>BEARING, Front Axle Pinion Kit (Outer-Pinion)</b>			
	74/	10-20-40.....	9.052	1 812 4052
	76	80-90.....	1	812 4052
<b>9.357-1</b>	<b>SHIM SET, Front Axle Differential And Pinion</b>			
	74/	10-20-40.....	9.050	1 812 4588
	74/75	80.....	1	929 408
	76	80-90.....	1	812 6502
<b>9.364-1</b>	<b>OIL SEAL, Front Axle Pinion Bearing</b>			
	74/	.....	1	998 092
<b>9.364-3</b>	<b>SLINGER, Front Axle Pinion Bearing Oil</b>			
	74/	(Inner-Front).....	1	916 372
	74/	(Outer-Rear) 80-90.....	9.064	1 636 566
	74/	(Outer-Rear) 10-20-40.....	1	908 301
<b>9.364-4</b>	<b>BAFFLE, Front Axle Pinion Bearing Oil (Rear)</b>			
	74/	.....	1	916 373

**9.368-1 SHAFT ASSEMBLY, Front Axle Drive****MODEL 30 (Incl. Gasket And Snap Ring)**

74/	(Left) 80-90.....	1	812 1396
74/	(Right) 80-90.....	1	812 1394

**MODEL 44**

74/	(Left) 10 (LDB).....	1	812 4356
74/	(Left) 10 (WDB).....	1	812 4406
76	(Left) 10 (Cherokee Chief).....	1	812 4373
74/	(Left) 25-45 (WDB).....	1	812 4373
74/	(Left) 25-45 (LDB).....	1	812 4368
74/	(Left) 26-46.....	1	812 4373
74/	(Right) 10 (LDB).....	1	812 4355
74/	(Right) 10 (WDB).....	1	812 4405
76	(Right) 10 (Cherokee Chief).....	1	812 4372
74/	(Right) 25-45 (WDB).....	1	812 4372
74/	(Right) 25-45 (LDB).....	1	812 4367
74/	(Right) 26-46.....	1	812 4372

**9.368-3 OIL SEAL, Front Axle Shaft Inner**

74/	10.....	2	812 4630
74/	20-40.....	2	812 4832
74/	80-90.....	2	812 1781

**9.368-6 RING, Front Axle Shaft Snap**

74/	10-20-40.....	2	535 2166
75	10-20-40.....	2	535 2097
74/	80-90.....	9.380	2 649 778

**9.368-7 GASKET, Front Axle Drive Shaft Flange**

74/	10-20-40.....	2	992 273
74/	80-90.....	8.296	2 649 784

**9.368-8 RETAINER, Front Axle Shaft Seal Outer**

74/	.....	1	812 6233
-----	-------	---	----------

**9.368-9 RETAINER, Front Axle Shaft Inner**

74/	.....	1	812 6232
-----	-------	---	----------

**9.369-1 FLANGE, Front Axle Shaft Drive**

74/	10-25-45.....	2	535 2616
74/	26-46.....	2	535 2633
74/	80-90.....	9.368	2 999 396

**9.369-2 ATTACHING PARTS, Drive Flange To Hub**

BOLT, Hexagon.....	74/ 80.....	17.038	12 G180126
STUD.....	74/ 26-46 (WDB).....	.....	12 535 2634
NUT, Hexagon.....	74/ 26-46 (WDB).....	17.406	12 G120369
WASHER, Spring.....	74/.....	.....	12 400 4807

**9.370-1 SPIDER ASSEMBLY, Front Axle Shaft**

74/	10-20-40.....	2	812 4589
74/	80-90.....	2	812 2993

**9.370-2 RING, Front Axle Shaft Spider Assembly Snap**

74/	.....	9.380	4 909 453
-----	-------	-------	-----------

**9.404-1 YOKE, Front Axle To Propeller Shaft**

74/	.....	1	935 685
-----	-------	---	---------

**9.404-1 SHIELD, Front Axle Yoke Dust**

74/	80-90.....	9.110	1 636 568
-----	------------	-------	-----------