

STEERING COLUMNS

2J

INDEX

	Page		Page
General	2J-1	Steering Column Installation	2J-13
Ignition Lock Cylinder	2J-37	Steering Column Removal	2J-11
Ignition Switch	2J-37	Steering Wheel Installation	2J-10
Service Diagnosis	2J-1	Steering Wheel Removal	2J-10
Specifications	2J-40	Tilt Column Overhaul—CJ and Scrambler Models	2J-30
Sport Steering Wheel Skirt Replacement	2J-11	Tilt Column Overhaul—Cherokee-Wagoneer-Truck Models	2J-24
Standard Column Overhaul—Automatic Transmission	2J-19	Tools	2J-41
Standard Column Overhaul—Manual Transmission	2J-13		
Steering Column Alignment	2J-10		

GENERAL

Three different steering column designs are used on Jeep vehicles. Models with automatic transmission use a nontilt column with column mounted gearshift mechanism. Models with manual transmission use a nontilt column with ignition key release lever. A six position tilt column is available as an option on all models.

All steering columns used on Jeep vehicles have anti-theft and energy absorbing features. Each column is designed to compress under impact.

The ignition lock cylinder and ignition switch are mounted on the column. When the lock cylinder is turned to LOCK position, the ignition switch and steering shaft cannot be operated. On models with automatic

transmission, the lock mechanism also prevents operation of the column mounted gearshift mechanism.

A center slip-type (telescoping) intermediate shaft is used on all models. It is attached to the steering gear with a flexible coupling and to the steering column with a universal joint.

SERVICE DIAGNOSIS

When diagnosing steering column malfunctions, refer to the Service Diagnosis Charts for the probable cause and correction procedures. To simplify chart use, they are divided into the various sub-systems within the column such as ignition system, lock mechanism, turn signal switch and electrical.

Service Diagnosis—Lock System

Condition	Possible Cause	Correction
WILL NOT LOCK	(1) Lockbolt spring broken or defective.	(1) Replace lock bolt spring.
HIGH EFFORT (REQUIRED TO TURN IGNITION KEY AND LOCK CYLINDER)	(1) Lock cylinder defective.	(1) Replace lock cylinder.
	(2) Ignition switch defective.	(2) Replace ignition switch.
	(3) Rack preload spring broken or deformed.	(3) Replace preload spring.

Service Diagnosis—Lock System (continued)

Condition	Possible Cause	Correction
HIGH EFFORT (REQUIRED TO TURN IGNITION KEY AND LOCK CYLINDER) (CON'T)	(4) Burr on lock sector, lock rack, housing, support or remote rod coupling. (5) Bent sector shaft. (6) Defective lock rack. (7) Remote rod bent, deformed. (8) Ignition switch mounting bracket bent. (9) Distorted coupling slot in lock rack (tilt column).	(4) Remove burr. (5) Replace shaft. (6) Replace lock rack. (7) Replace rod. (8) Straighten or replace. (9) Replace lock rack.
WILL STICK IN "START"	(1) Remote rod deformed. (2) Ignition switch mounting bracket bent.	(1) Straighten or replace. (2) Straighten or replace.
KEY CANNOT BE REMOVED IN "OFF-LOCK"	(1) Ignition switch is not adjusted correctly. (2) Defective lock cylinder.	(1) Adjust switch. (2) Replace lock cylinder.
LOCK CYLINDER CAN BE REMOVED WITHOUT DEPRES- SING RETAINER	(1) Lock cylinder with defective retainer. (2) Burr over retainer slot in housing cover or on cylinder retainer.	(1) Replace lock cylinder. (2) Remove burr.
HIGH EFFORT ON LOCK CYLINDER BETWEEN "OFF" AND "OFF-LOCK"	(1) Distorted lock rack. (2) Burr on tang of shift gate (automatic column). (3) Gearshift linkage not adjusted.	(1) Replace lock rack. (2) Remove burr. (3) Adjust linkage.

Service Diagnosis—Steering Column

Condition	Possible Cause	Correction
NOISE IN COLUMN	<ul style="list-style-type: none"> (1) One click when in "off-lock" position and the steering wheel is moved (all except automatic column). (2) Coupling bolts not tightened. (3) Lack of grease on bearings or bearing surfaces. (4) Upper shaft bearing worn or broken. (5) Lower shaft bearing worn or broken. (6) Column not correctly aligned. (7) Coupling pulled apart. (8) Broken coupling lower joint. (9) Steering shaft snap ring not seated. (10) Shroud loose on shift bowl. Housing loose on jacket—will be noticed with ignition in "off-lock" and when torque is applied to steering wheel. 	<ul style="list-style-type: none"> (1) Normal—lock bolt is seating. (2) Tighten pinch bolts. (3) Lubricate with chassis grease. (4) Replace bearing assembly. (5) Replace bearing. Check shaft and replace if scored. (6) Align column. (7) Replace coupling. (8) Repair or replace joint and align column. (9) Replace snap ring. Check for proper seating in groove. (10) Position shroud over lugs on shift bowl. Tighten mounting screws.
HIGH STEERING SHAFT EFFORT	<ul style="list-style-type: none"> (1) Column misaligned. (2) Defective upper or lower bearing. (3) Tight steering shaft universal joint. (4) Flash on I.D. of shift tube at plastic joint (tilt column only). (5) Upper or lower bearings siezed. 	<ul style="list-style-type: none"> (1) Align column. (2) Replace as required. (3) Repair or replace. (4) Replace shift tube. (5) Replace bearings.
LASH IN MOUNTED COLUMN ASSEMBLY	<ul style="list-style-type: none"> (1) Column mounting bracket bolts loose. (2) Broken weld nuts on column jacket. (3) Column capsule bracket sheared. (4) Column bracket to column jacket mounting bolts loose. (5) Loose lock shoes in housing (tilt column only). 	<ul style="list-style-type: none"> (1) Tighten bolts. (2) Replace column jacket. (3) Replace bracket assembly. (4) Tighten to specified torque. (5) Replace shoes.

Service Diagnosis—Steering Column (Continued)

Condition	Possible Cause	Correction
LASH IN MOUNTED COLUMN ASSEMBLY (CON'T)	<ul style="list-style-type: none"> (6) Loose pivot pins (tilt column only). (7) Loose lock shoe pin (tilt column only). (8) Loose support screws (tilt column only). 	<ul style="list-style-type: none"> (6) Replace pivot pins and support. (7) Replace pin and housing. (8) Tighten screws.
HOUSING LOOSE (TILT COLUMN ONLY)	<ul style="list-style-type: none"> (1) Excessive clearance between holes in support or housing and pivot pin diameters. (2) Housing support-screws loose. 	<ul style="list-style-type: none"> (1) Replace pivot pins and support. (2) Tighten screws.
STEERING WHEEL LOOSE—EVERY OTHER TILT POSITION (TILT COLUMN ONLY)	<ul style="list-style-type: none"> (1) Loose fit between lock shoe and lock shoe pivot pin. 	<ul style="list-style-type: none"> (1) Replace lock shoes and pivot pin.
STEERING COLUMN NOT LOCKING IN ANY TILT POSITION (TILT COLUMN ONLY)	<ul style="list-style-type: none"> (1) Lock shoe seized on pivot pin. (2) Lock shoe grooves have burrs or are filled with foreign material. (3) Lock shoe springs weak or broken. 	<ul style="list-style-type: none"> (1) Replace lock shoes and pin. (2) Clean or replace lock shoes. (3) Replace springs.
NOISE WHEN TILTING COLUMN (TILT COLUMN ONLY)	<ul style="list-style-type: none"> (1) Upper tilt bumpers worn. (2) Tilt spring rubbing in housing. 	<ul style="list-style-type: none"> (1) Replace tilt bumper. (2) Lubricate with chassis grease.
ONE CLICK WHEN IN "OFF-LOCK" POSITION AND THE STEERING WHEEL IS MOVED	<ul style="list-style-type: none"> (1) Seating of lock bolt. 	<ul style="list-style-type: none"> (1) None. Click is normal characteristic sound produced by lock bolt as it seats.
HIGH SHIFT EFFORT (AUTOMATIC AND TILT COLUMN ONLY)	<ul style="list-style-type: none"> (1) Column not correctly aligned. (2) Lower bearing not aligned correctly. (3) Lack of grease on seal or lower bearing areas. 	<ul style="list-style-type: none"> (1) Align column. (2) Assemble correctly. (3) Lubricate with chassis grease.
IMPROPER TRANSMISSION SHIFTING—AUTOMATIC AND TILT COLUMN ONLY	<ul style="list-style-type: none"> (1) Sheared shift tube joint. (2) Improper transmission gearshift linkage adjustment. (3) Loose lower shift lever. 	<ul style="list-style-type: none"> (1) Replace shift tube. (2) Adjust linkage. (3) Replace shift tube.

Service Diagnosis—Ignition System

Condition	Possible Cause	Correction
<p>IGNITION SWITCH ELECTRICALLY INOPERATIVE</p>	<ul style="list-style-type: none"> (1) Loose or defective switch connector. (2) Feed wire open (fusible link). (3) Defective ignition switch. 	<ul style="list-style-type: none"> (1) Tighten or replace connector. (2) Repair or replace. (3) Replace ignition switch.
<p>ENGINE WILL NOT CRANK</p>	<ul style="list-style-type: none"> (1) Ignition switch not adjusted properly. 	<ul style="list-style-type: none"> (1) Adjust switch.
<p>IGNITION SWITCH WILL NOT ACTUATE MECHANICALLY</p>	<ul style="list-style-type: none"> (1) Defective ignition switch. (2) Defective lock sector. (3) Defective remote rod. 	<ul style="list-style-type: none"> (1) Replace switch. (2) Replace lock sector. (3) Replace remote rod.
<p>IGNITION SWITCH CANNOT BE ADJUST- ED CORRECTLY</p>	<ul style="list-style-type: none"> (1) Remote rod deformed. 	<ul style="list-style-type: none"> (1) Repair, straighten or replace.

60659E

Service Diagnosis—Turn Signal

Condition	Possible Cause	Correction
<p>TURN SIGNAL WILL NOT CANCEL</p>	<ul style="list-style-type: none"> (1) Loose switch mounting screws. (2) Switch or anchor bosses broken. (3) Broken, missing or out of position detent, or cancelling spring. 	<ul style="list-style-type: none"> (1) Tighten screws. (2) Replace switch. (3) Reposition springs or replace switch as required.

60659F

Service Diagnosis — Turn Signal (Continued)

Condition	Possible Cause	Correction
TURN SIGNAL DIFFICULT TO OPERATE	(1) Turn signal lever loose. (2) Switch yoke broken or distorted. (3) Loose or misplaced springs. (4) Foreign parts and/or materials in switch. (5) Switch mounted loosely.	(1) Tighten mounting screw. (2) Replace switch. (3) Reposition springs or replace switch. (4) Remove foreign parts and/or material. (5) Tighten mounting screws.
TURN SIGNAL WILL NOT INDICATE LANE CHANGE	(1) Broken lane change pressure pad or spring hanger. (2) Broken, missing or misplaced lane change spring. (3) Jammed wires.	(1) Replace switch. (2) Replace or reposition as required. (3) Loosen mounting screws, reposition wires and retighten screws.
TURN SIGNAL WILL NOT STAY IN TURN POSITION	(1) Foreign material or loose parts impeding movement of switch yoke. (2) Defective switch.	(1) Remove material and/or parts. (2) Replace switch.
HAZARD SWITCH CANNOT BE PULLED OUT	(1) Foreign material between hazard support cancelling leg and yoke.	(1) Remove foreign material. (a) No foreign material impeding function of hazard switch— replace turn signal switch.

Service Diagnosis — Turn Signal (Continued)

Condition	Possible Cause	Correction
NO TURN SIGNAL LIGHTS	<p>(1) Inoperative turn signal flasher.</p> <p>(2) Defective or blown fuse.</p> <p>(3) Loose chassis to column harness connector.</p> <p>(4) Disconnect column to chassis connector. Connect new switch to chassis and operate switch by hand. If vehicle lights now operate normally, signal switch is inoperative.</p> <p>(5) If vehicle lights do not operate check chassis wiring for opens, grounds, etc.</p>	<p>(1) Replace turn signal flasher.</p> <p>(2) Replace fuse.</p> <p>(3) Connect securely.</p> <p>(4) Replace signal switch.</p> <p>(5) Repair chassis wiring as required.</p>
INSTRUMENT PANEL TURN INDICATOR LIGHTS ON BUT NOT FLASHING	<p>(1) Burned out or damaged front or rear turn signal bulb.</p> <p>(2) If vehicle lights do not operate, check light sockets for high resistance connections, the chassis wiring for opens, grounds, etc.</p> <p>(3) Inoperative flasher.</p> <p>(4) Loose chassis to column harness connection.</p> <p>(5) Inoperative turn signal switch.</p> <p>(6) To determine if turn signal switch is defective, substitute new switch into circuit and operate switch by hand. If the vehicle's lights operate normally, signal switch is inoperative.</p>	<p>(1) Replace bulb.</p> <p>(2) Repair chassis wiring as required.</p> <p>(3) Replace flasher.</p> <p>(4) Connect securely.</p> <p>(5) Replace turn signal switch.</p> <p>(6) Replace turn signal switch.</p>

Service Diagnosis—Turn Signal (Continued)

Condition	Possible Cause	Correction
<p>STOP LIGHT NOT ON WHEN TURN INDICATED</p>	<p>(1) Loose column to chassis connection.</p> <p>(2) Disconnect column to chassis connector. Connect new switch into system without removing old. Operate switch by hand. If brake lights work with switch in the turn position, signal switch is defective.</p> <p>(3) If brake lights do not work check connector to stop light sockets for grounds, opens, etc.</p>	<p>(1) Connect securely.</p> <p>(2) Replace signal switch.</p> <p>(3) Repair connector to stop light circuits using service manual as guide.</p>
<p>TURN INDICATOR PANEL LIGHTS NOT FLASHING</p>	<p>(1) Burned out bulbs.</p> <p>(2) High resistance to ground at bulb socket.</p> <p>(3) Opens, grounds in wiring harness from front turn signal bulb socket to indicator lights.</p>	<p>(1) Replace bulbs.</p> <p>(2) Replace socket.</p> <p>(3) Locate and repair as required.</p>
<p>TURN SIGNAL LIGHTS FLASH VERY SLOWLY</p>	<p>(1) High resistance ground at light sockets.</p> <p>(2) Incorrect capacity turn signal flasher or bulb.</p> <p>(3) If flashing rate is still extremely slow, check chassis wiring harness from the connector to light sockets for high resistance.</p>	<p>(1) Repair high resistance grounds at light sockets.</p> <p>(2) Replace turn signal flasher or bulb.</p> <p>(3) Locate and repair as required.</p>

Service Diagnosis — Turn Signal (Continued)

Condition	Possible Cause	Correction
<p>TURN SIGNAL LIGHTS FLASH VERY SLOWLY (CON'T.)</p>	<p>(4) Loose chassis to column harness connection.</p> <p>(5) Disconnect column to chassis connector. Connect new switch into system without removing old. Operate switch by hand. If flashing occurs at normal rate, the signal switch is defective.</p>	<p>(4) Connect securely.</p> <p>(5) Replace turn signal switch.</p>
<p>HAZARD SIGNAL LIGHTS WILL NOT FLASH—TURN SIGNAL FUNCTIONS NORMALLY</p>	<p>(1) Blown fuse.</p> <p>(2) Inoperative hazard warning flasher.</p> <p>(3) Loose chassis-to-column harness connection.</p> <p>(4) Disconnect column to chassis connector. Connect new switch into system without removing old. Depress the hazard warning lights. If they now work normally, turn signal switch is defective.</p> <p>(5) If lights do not flash, check wiring harness "K" lead for open between hazard flasher and connector. If open, fuse block is defective.</p>	<p>(1) Replace fuse.</p> <p>(2) Replace hazard warning flasher in fuse panel.</p> <p>(3) Connect securely.</p> <p>(4) Replace turn signal switch.</p> <p>(5) Repair or replace brown wire or connector as required.</p>

STEERING COLUMN ALIGNMENT

- (1) Loosen all toeplate screws.
- (2) Remove instrument panel lower trim.
- (3) Loosen column mounting bracket-to-instrument-panel attaching bolts.
- (4) Pull steering column upward. Maintain upward pressure and tighten instrument panel-to-column mounting bracket bolts to 20 foot-pounds (27 N•m) torque.
- (5) Install lower clamp bracket and tighten bolts to 20 foot-pounds (27 N•m) torque.
- (6) Tighten toeplate screws to 10 foot-pounds (14 N•m) torque.
- (7) Install instrument panel lower trim.
- (8) On vehicles with automatic transmission, check gearshift manual linkage for proper operation. Refer to Chapter 2C—Automatic Transmission.

STEERING WHEEL REMOVAL

CJ Models

- (1) Disconnect battery negative cable.
- (2) Place front wheels in straight-ahead position.
- (3) Remove horn button. Pull button straight up to remove.
- (4) Remove steering wheel nut and washer.
- (5) Remove receiver bushing attaching screws and remove bushing.
- (6) Remove horn button receiver and contact plate.
- (7) Paint or scribe alignment marks on steering wheel and steering shaft for assembly reference.
- (8) Remove steering wheel using Puller J-21232 (fig. 2J-1).

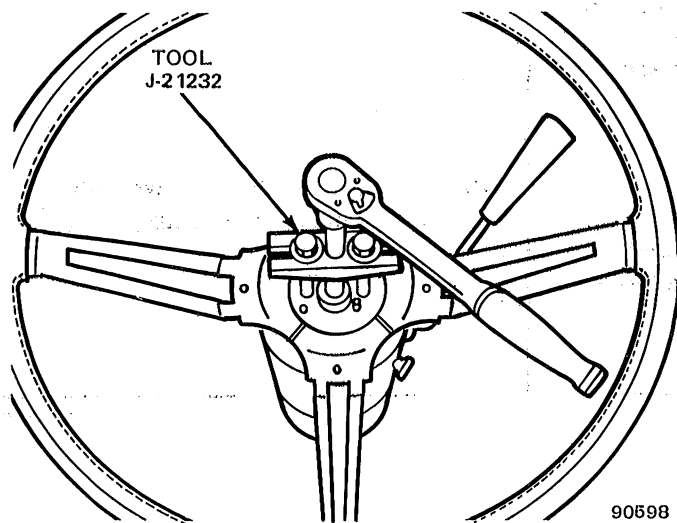

Fig. 2J-1 Steering Wheel Removal

90598

Cherokee-Wagoneer-Truck Models

- (1) Disconnect battery negative cable.
- (2) Place front wheels in straight-ahead position.

(3) On models with standard steering wheel, remove horn cover attaching screws from underside of wheel and remove cover. On models with sport steering wheel, remove horn button by pulling button upward.

(4) On models with standard steering wheel, remove horn wire. Disconnect wire at steering wheel switch. Unseat retainer that holds horn wire and spring in canceling cam yoke and remove wire, retainer, and spring as assembly.

(5) Remove steering wheel nut and washer.

(6) On models with sport steering wheel, remove receiver bushing attaching screws and remove bushing, horn button receiver, and contact plate.

(7) Paint or scribe alignment marks on steering wheel and steering shaft for assembly reference.

(8) Remove steering wheel using Puller J-21232 (fig. 2J-1).

STEERING WHEEL INSTALLATION

CAUTION: Some steering shafts have metric steering wheel nut threads. Inspect and identify the shaft thread type before installing a replacement nut. Metric shafts have an identifying groove in the steering wheel splines (fig. 2J-2). American thread shafts do not have this groove.

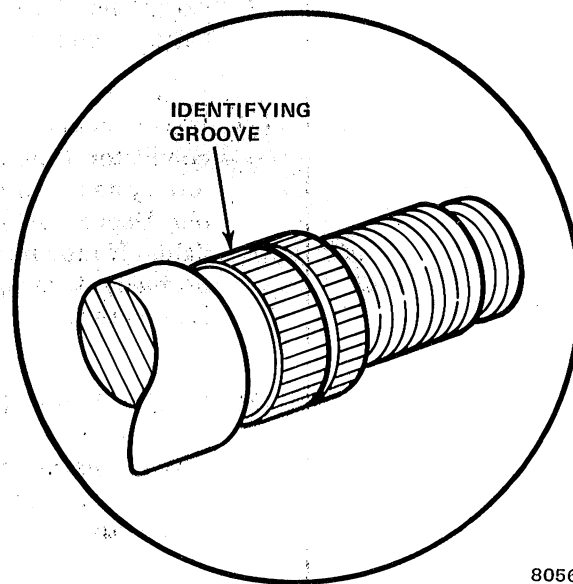

80567

Fig. 2J-2 Metric Steering Shaft Identification

CJ Models

(1) Align reference marks on steering shaft and steering wheel and install wheel.

(2) Install contact plate and horn button receiver. Install receiver so horn button locating notch is at 12 o'clock position.

(3) Install receiver bushing and bushing attaching screws.

- (4) Install steering wheel washer and nut. Tighten nut to 30 foot-pounds (41 N•m) torque.
- (5) Install horn button.
- (6) Connect battery negative cable.
- (7) Reset clock, if equipped.

Cherokee-Wagoneer-Truck Models

- (1) Align reference marks on steering shaft and steering wheel and install wheel.
- (2) On models with sport steering wheel (fig. 2J-3), install contact plate, horn button receiver, and receiver bushing. Be sure to install receiver so horn button locating notch is at 12 o'clock position.
- (3) Install steering wheel washer and nut. Tighten nut to 30 foot-pounds (41 N•m) torque.
- (4) On models with standard steering wheel, insert spring and horn wire in canceling cam yoke. Seat horn wire retainer in cam yoke and connect opposite end of wire to steering wheel switch.
- (5) Install horn button.
- (6) Connect battery negative cable.
- (7) Reset clock, if equipped.

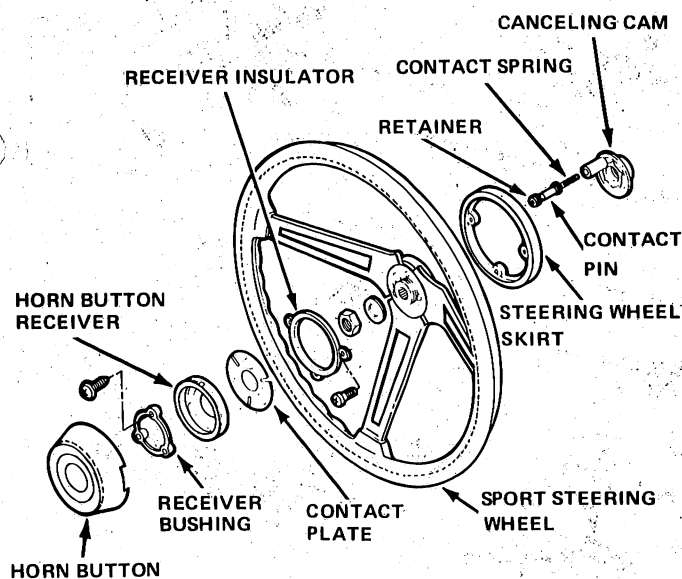

90188

Fig. 2J-3 Sport Steering Wheel Assembly

SPORT STEERING WHEEL SKIRT REPLACEMENT

- (1) Disconnect battery negative cable.
- (2) Place wheels in straight-ahead position.
- (3) Remove horn button. Pull straight up on button to remove.
- (4) Remove steering wheel nut and washer.
- (5) Remove receiver bushing attaching screws and remove bushing, horn button receiver, and contact plate (fig. 2J-3).

- (6) Remove steering wheel using Tool J-21232 (fig. 2J-1).
- (7) Remove receiver insulator attaching screws and remove insulator and skirt (fig. 2J-3).
- (8) Color coat replacement skirt. Refer to Chapter 3B—Metal Repair and Painting for color coat procedure.
- (9) Align and install replacement skirt and receiver insulator on steering wheel and install insulator attaching screws.
- (10) Align reference marks on steering shaft and wheel and install wheel.
- (11) Install contact plate and horn button receiver. Install receiver so horn button locating notch is at 12 o'clock position.
- (12) Install receiver bushing and bushing attaching screws.
- (13) Install steering wheel washer and nut. Tighten nut to 30 foot-pounds (41 N•m) torque.
- (14) Install horn button. Align button tab with receiver notch and press button downward until seated.
- (15) Connect battery negative cable.
- (16) Reset clock, if equipped.

STEERING COLUMN REMOVAL

CAUTION: Handle the steering column with special care after it is removed from the vehicle. Sharp blows on the end of the steering shaft or shift lever, leaning on the column assembly, or dropping the assembly could shear or loosen the plastic fasteners that maintain column rigidity.

- (1) Disconnect battery negative cable.
- (2) On vehicles with automatic transmission, disconnect transmission shift rod at steering column shift lever.

NOTE: On Cherokee and Wagoneer models with automatic transmission and power brakes, the gearshift lever must be moved to the "1" range position to gain access to the shift rod-to-shift lever retaining clip.

- (3) Remove steering column-to-intermediate shaft U-joint pinch bolt.

CAUTION: Do not attempt to separate the intermediate shaft and steering column at this time. If separated, the plastic connector injected into the intermediate shaft could be damaged.

- (4) On Cherokee and Wagoneer models with air conditioning, remove left air duct extension.
- (5) Remove steering column-to-instrument panel bezel. On Cherokee, Wagoneer, and Truck models, screws attaching two halves of bezel are located behind lower bezel half.
- (6) Remove bolts attaching steering column mounting bracket to instrument panel.
- (7) Remove bolts attaching steering column mounting bracket to steering column and remove bracket.

2J-12 STEERING COLUMNS

CAUTION: To avoid damaging the mounting bracket breakaway capsules, store the bracket in a safe place until service operations are completed.

(8) Remove top and bottom toeplates.

- (9) Disconnect wiring harness at ignition switch.
 (10) Disconnect Cruise Command wiring harness connector, if equipped.
 (11) Separate steering column from intermediate shaft and remove steering column.

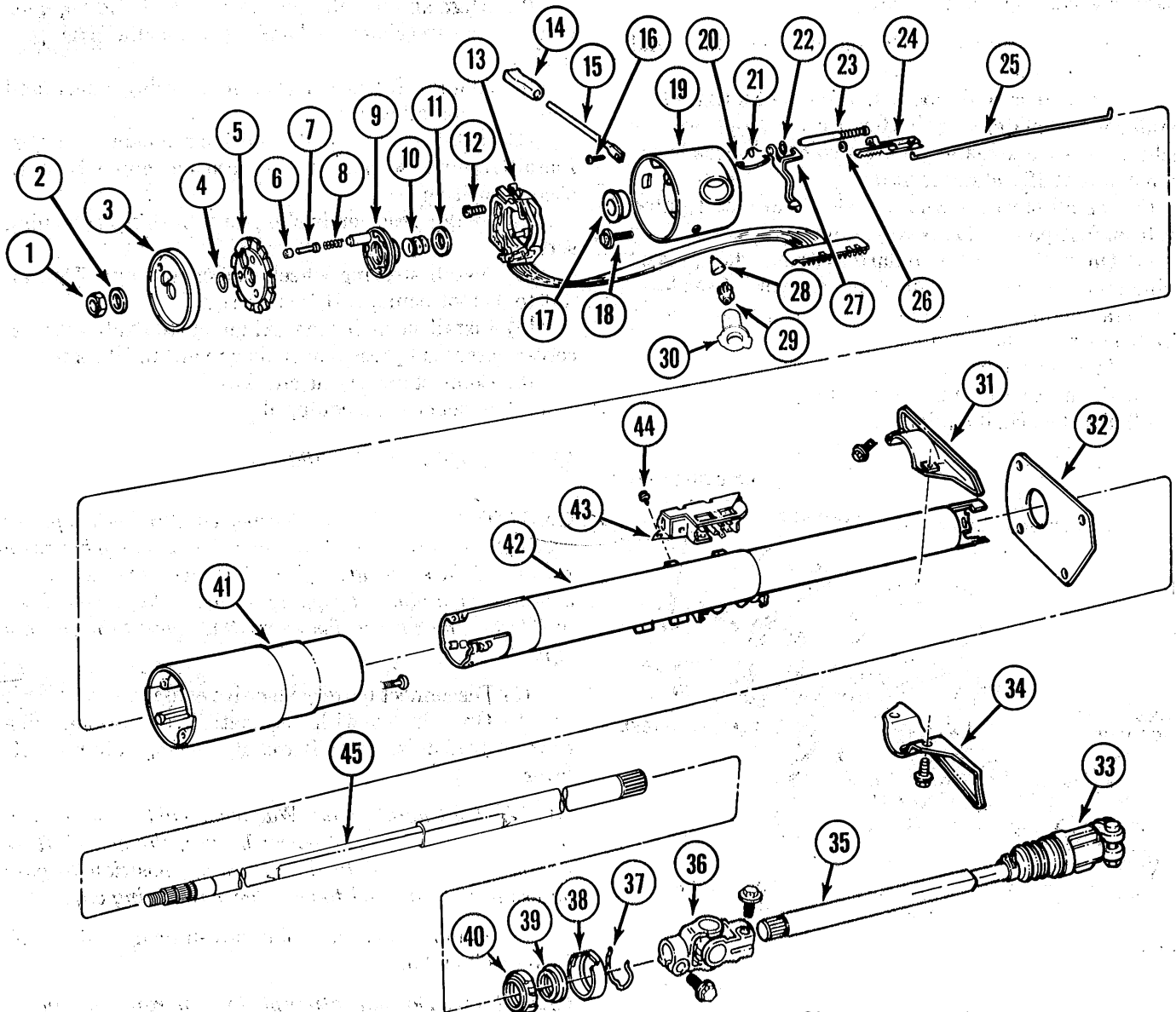

1. STEERING WHEEL NUT
2. WASHER
3. LOCK PLATE COVER
4. STEERING SHAFT SNAP RING
5. LOCKPLATE
6. RETAINER
7. HORN CONTACT PIN
8. SPRING
9. CANCELING CAM
10. UPPER BEARING PRELOAD SPRING
11. THRUST WASHER
12. TURN SIGNAL SWITCH SCREW (3)
13. TURN SIGNAL SWITCH
14. TURN SIGNAL LEVER KNOB
15. TURN SIGNAL LEVER

16. TURN SIGNAL LEVER SCREW
17. UPPER BEARING
18. HOUSING RETAINING SCREW (4)
19. HOUSING
20. RACK PRELOAD SPRING
21. KEY RELEASE LEVER SPRING
22. WAVE WASHER
23. LOCK BOLT
24. LOCK RACK
25. REMOTE ROD
26. SPRING WASHER
27. KEY RELEASE LEVER
28. HAZARD WARNING SWITCH KNOB
29. LOCK SECTOR
30. LOCK CYLINDER

31. TOE PLATE (UPPER HALF)
32. SEAL
33. INTERMEDIATE SHAFT COUPLING
34. TOE PLATE (LOWER HALF)
35. INTERMEDIATE SHAFT
36. INTERMEDIATE SHAFT-TO-STEERING SHAFT U-JOINT
37. SNAP RING
38. RETAINER
39. LOWER BEARING
40. LOWER BEARING ADAPTER
41. SHROUD
42. JACKET
43. IGNITION SWITCH
44. IGNITION SWITCH SCREW (2)
45. STEERING SHAFT

Fig. 2J-4 Steering Column—Manual Transmission

STEERING COLUMN INSTALLATION

CAUTION: Use only the specified screws, bolts, and nuts when servicing the column. Do not use any substitute fasteners. Tighten all fasteners to the specified torque only to maintain the energy-absorbing (compression) action of the column. Bolts and screws longer than specified must not be used as they may prevent the column from compressing under impact. The bolts or nuts securing the column mounting bracket to the instrument panel must be tightened to the proper torque so that the bracket will break away under impact.

- (1) Install steering column in vehicle and connect column to intermediate shaft.
- (2) Install intermediate shaft-to-column U-joint pinch bolt. Tighten bolt to 45 foot-pounds (61 N•m) torque.
- (3) Connect Cruise Command wire harness connector, if equipped.
- (4) Connect wiring harness connectors to ignition switch. Install white connector first—black connector last.
- (5) Install top and bottom toeplates but do not tighten attaching bolts completely.
- (6) Install mounting bracket on steering column and tighten bracket attaching bolts to 20 foot-pounds (27 N•m) torque.
- (7) Align steering column mounting bracket and instrument panel and loosely install mounting bracket-to-instrument panel bolts.
- (8) Pull steering column upward and tighten column mounting bracket-to-instrument panel bolts to 20 foot-pounds (27 N•m) torque. Be sure to maintain upward pressure on column when tightening bolts.
- (9) Tighten toe plate bolts to 10 foot-pounds (14 N•m) torque.
- (10) Install both halves of steering column-to-instrument panel bezel.
- (11) On Cherokee, Wagoneer and Truck models with air conditioning, install left air duct extension.
- (12) Connect transmission shift rod to steering column shift lever.
- (13) On vehicles with automatic transmission, check operation of gearshift manual linkage and adjust linkage, if necessary. Refer to Chapter 2C—Automatic Transmission.
- (14) Connect all electrical components and check for proper operation.
- (15) Install instrument panel trim and left side air conditioning duct, if equipped.
- (16) Connect battery negative cable.
- (17) Reset clock, if equipped.

STANDARD COLUMN OVERHAUL/MANUAL TRANSMISSION

Column Disassembly

NOTE: Steering column removal is not necessary if only the lock plate cover, lock plate, steering shaft snap ring, canceling cam, turn signal switch, upper bearing preload spring, or lock cylinder are to be serviced (fig. 2J-4). However, the column must be removed in order to service any of the remaining components. If the column is removed, remove the column-to-instrument panel mounting bracket and install Support Fixture J-23074 (fig. 2J-5). Mount the column in a vise by clamping the support fixture flange in the vise.

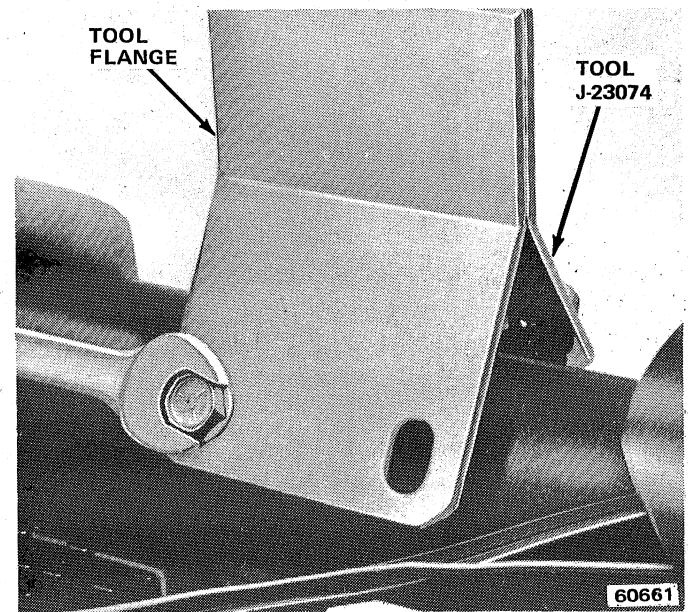

Fig. 2J-5 Steering Column Support Fixture Installation

- (1) Place front wheels in straight-ahead position.
- (2) Disconnect battery negative cable.
- (3) Cover painted areas of column.
- (4) Remove steering wheel.
- (5) Remove lock plate cover. Use two screwdrivers to pry cover off lock plate and out of column.
- (6) Compress lock plate and unseat steering shaft snap ring as follows:
 - (a) Inspect and identify steering shaft nut thread type. Metric shafts have identifying groove in steering wheel locating splines (fig. 2J-2). American thread shafts do not have this groove.
 - (b) If shaft has American threads, use tool J-23653 as is to compress lock plate and unseat snap ring (fig. 2J-6).
 - (c) If shaft has metric threads, replace compressor tool standard forcing screw with Metric Forcing Screw J-23653-4 before installing tool on steering shaft.

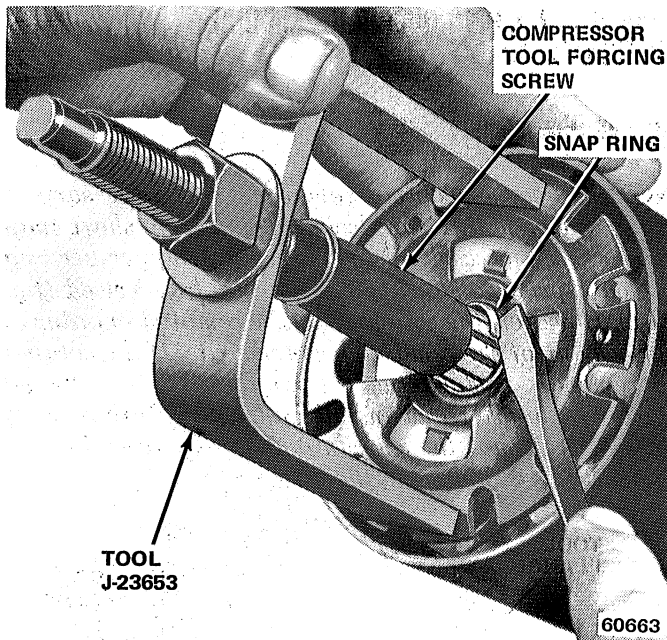

Fig. 2J-6 Steering Shaft Snap Ring Removal

WARNING: The lock plate is under strong spring tension. Do not attempt to remove the steering shaft snap ring without using the compressor tool.

(7) Remove lock plate compressor tool and snap ring. Discard snap ring.

CAUTION: When the steering shaft snap ring is removed, the shaft is free in the column. During bench overhaul, remove the shaft by pulling it out from the lower end of column. Do not allow the shaft to fall out whenever the column is removed from the vehicle.

(8) Remove lock plate, canceling cam, upper bearing preload spring, and thrust washer from shaft.

(9) Remove hazard warning switch knob. Press knob inward and unthread knob from column.

(10) On vehicles without Cruise Command, remove turn signal lever attaching screw and remove lever.

(11) On vehicles with Cruise Command, disconnect two of four wires at switch connector. Fold wires back along harness. Tape wires to harness and tape length of string to harness to aid removal.

(12) Unhook turn signal switch wire harness connector from bracket at lower end of steering column.

(13) Disconnect instrument panel harness connector from turn signal switch harness connector by lifting plastic lock tab on connector and separating connectors (fig. 2J-7).

(14) Wrap tape around turn signal switch harness connector to prevent snagging during removal.

(15) Remove turn signal switch attaching screws and remove switch. Pull switch and harness straight up and out of housing (fig. 2J-8).

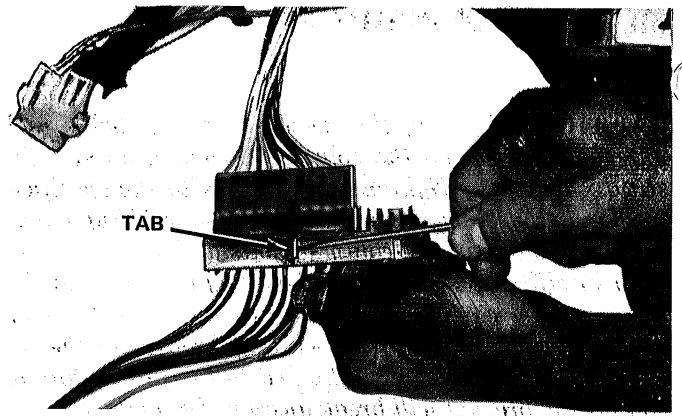

Fig. 2J-7 Turn Signal Switch Removal/Installation

(16) On vehicles with Cruise Command, remove turn signal lever and switch and remove switch harness using string previously taped in place.

(17) Turn ignition lock cylinder (clockwise) two detent positions beyond Off-LOCK position.

(18) Compress lock cylinder retaining tab using thin-bladed screwdriver and remove lock cylinder from column.

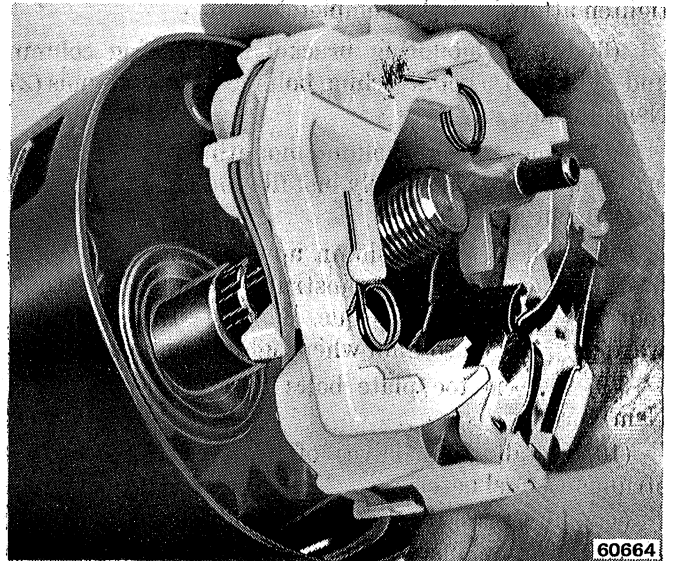

Fig. 2J-8 Disconnecting Turn Signal Switch Harness

NOTE: The lock cylinder retaining tab is accessible through the slot adjacent to the turn signal switch mounting boss (fig. 2J-9). If the retaining tab is not visible through the slot, scrape or knock any casting flash out of the slot to provide access.

(19) Remove ignition switch from lower end of column (fig. 2J-10).

(20) Remove screws attaching housing and shroud to column jacket (fig. 2J-11) and remove housing and shroud.

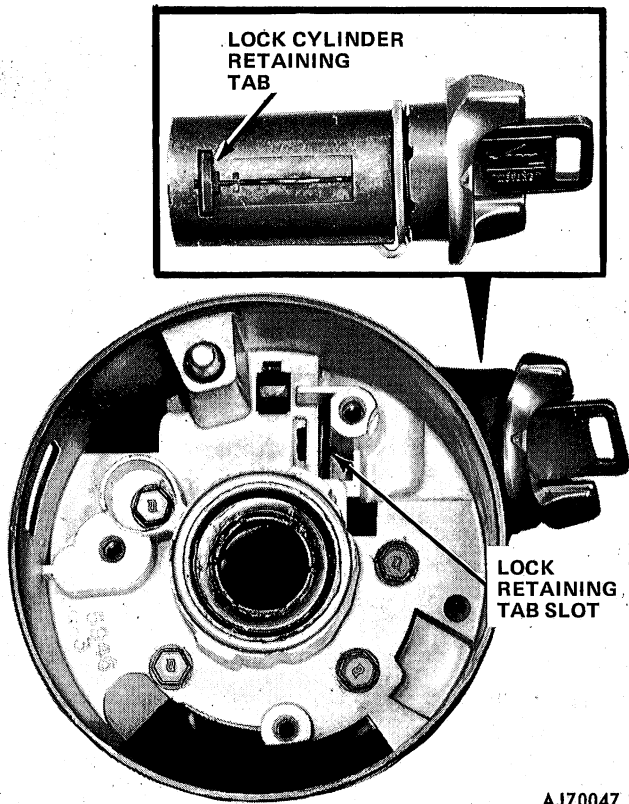

Fig. 2J-9 Lock Cylinder Retaining Tab Location

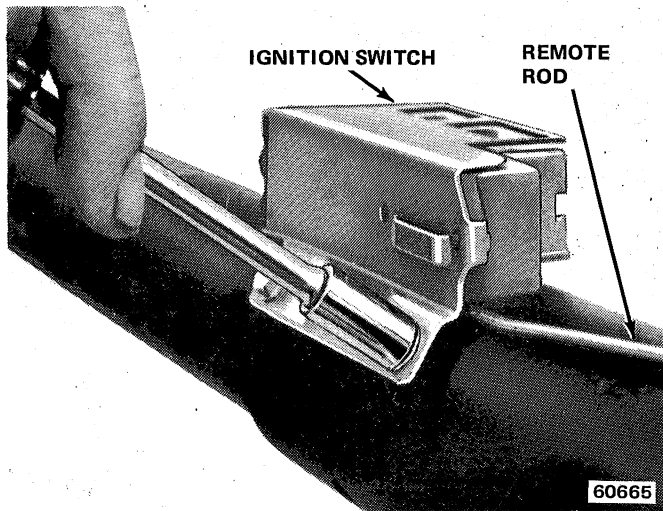

Fig. 2J-10 Ignition Switch Removal/Installation

- (21) Disengage remote rod from lock rack.
- (22) Remove screws attaching shroud to housing (fig. 2H-12) and remove housing from shroud.
- (23) Remove wave washer from key release lever pivot and remove key release lever and spring (fig. 2J-13).
- (24) Remove lock rack and lock bolt assembly (fig. 2J-14).

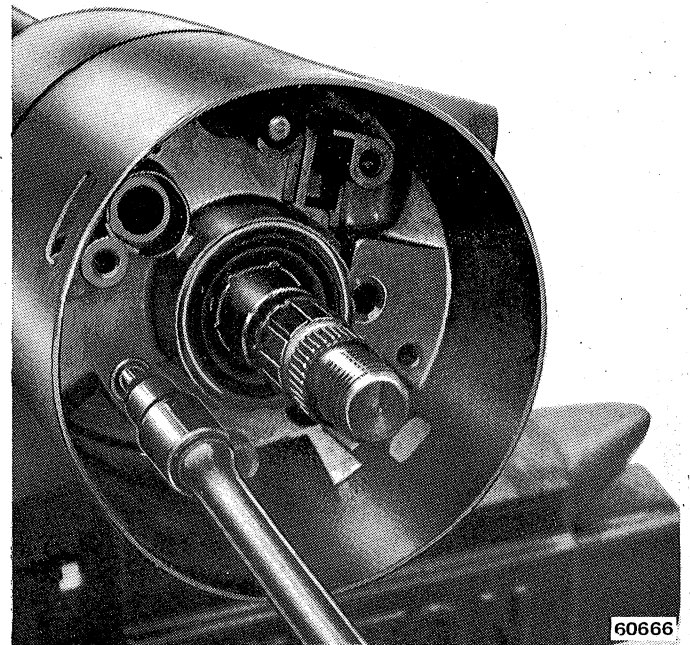

Fig. 2J-11 Housing and Shroud Removal/Installation

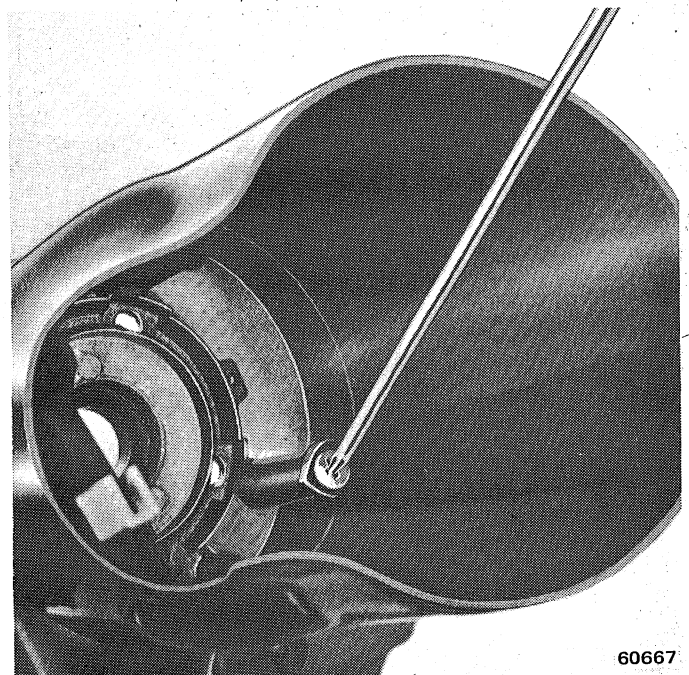

Fig. 2J-12 Removing Shroud From Housing

- (25) Remove rack preload spring (fig. 2J-15).
- (26) Remove lock sector through lock cylinder hole in housing. Push on block tooth of sector with blunt punch to remove (fig. 2J-16).

NOTE: Although the preceding steps can be performed with the column mounted in the vehicle, the following steps can be performed only after the column has been removed.

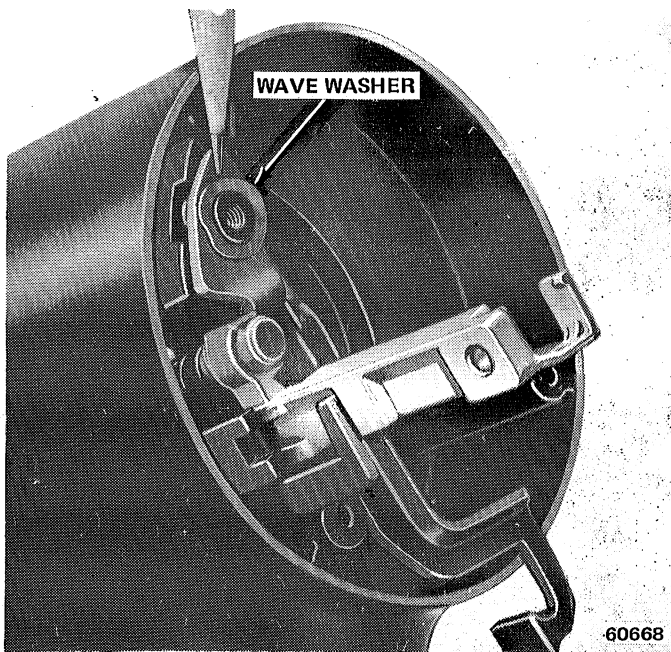

Fig. 2J-13 Wave Washer Position

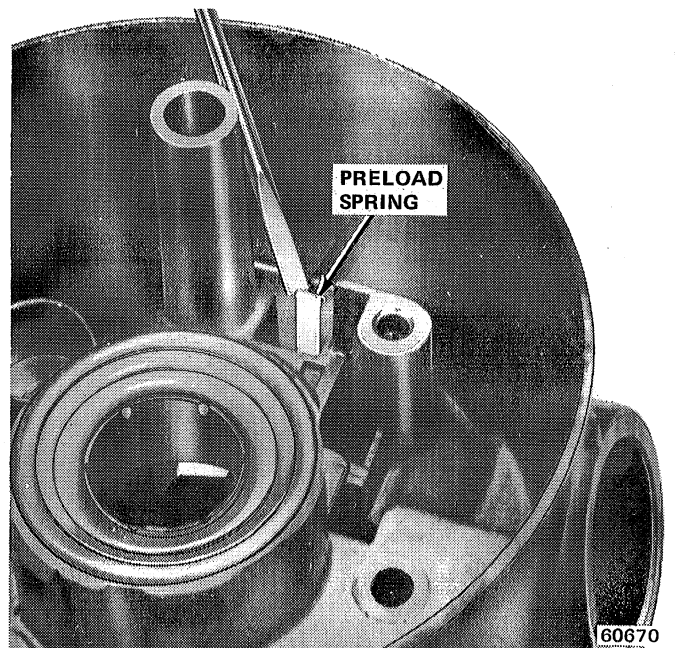

Fig. 2J-15 Rack Preload Spring Removal/Installation

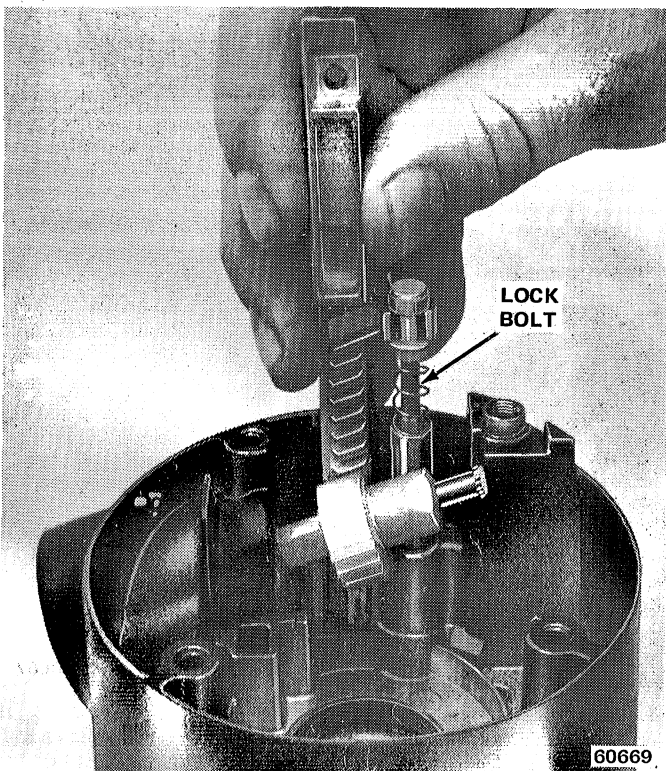

Fig. 2J-14 Lock Rack and Lock Bolt Removal

(27) Remove column from vehicle, if necessary, and mount column in vise using Support Fixture Tool J-23074 (fig. 2J-5).

(28) Remove steering shaft if not removed previously.

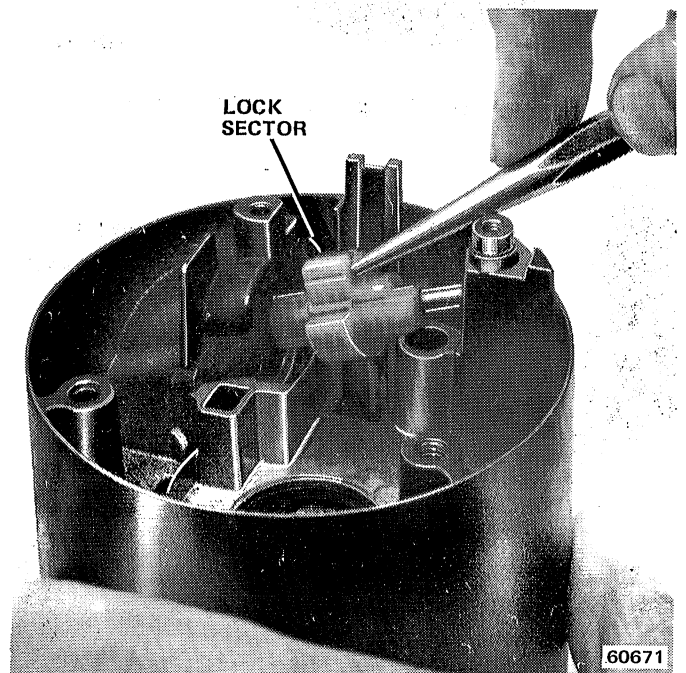

Fig. 2J-16 Lock Sector Removal

(29) Remove spring clip from lower bearing retainer and remove retainer, bearing, and adapter,

Column Assembly

CAUTION: Use only the specified screws, bolts, and nuts when servicing the column and tighten all fasteners to recommended torque values only to maintain the energy-absorbing (compressing) action of the column.

Incorrect length screws or bolts can prevent the column from compressing under impact. The bolts and nuts that attach the column mounting bracket to the column and instrument panel must also be tightened to the proper torque so that the bracket will break away under impact.

(1) Coat all friction and bearing surfaces with chassis grease before assembly.

(2) Install lock sector on sector shaft. Install sector through lock cylinder hole in housing (fig. 2J-17). Use blunt tool to press sector onto shaft. Be sure sector turns freely after installation.

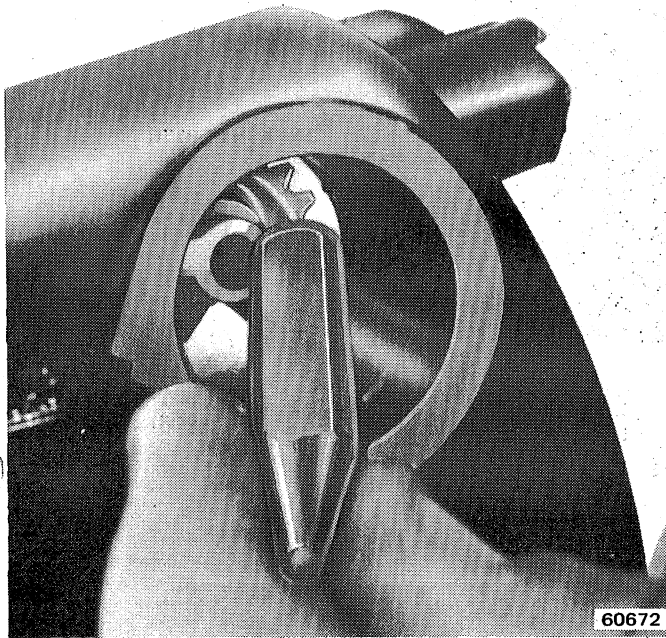

60672

Fig. 2J-17 Sector Installation

(3) Install rack preload spring (fig. 2J-15). Bowed side of spring must bear against lock rack when rack is installed.

(4) Assemble lock bolt and lock rack (fig. 2J-18).

(5) Install assembled lock bolt and lock rack in housing. Mate block tooth of lock rack with block tooth of sector (fig. 2J-19).

(6) Install key-release lever return spring over post in housing (fig. 2J-20). Insert release lever finger in lock rack slot and position hole in lever over threaded hole in housing post (fig. 2J-21). Be sure inner end of spring contacts release lever.

(7) Raise key-release lever slightly and install end of release lever spring between lever and housing boss (fig. 2J-22).

(8) Coat wave washer with chassis grease and install washer on post and over release lever (fig. 2J-13).

(9) Position shroud on housing and install attaching screws. Tighten screws to 18 inch-pounds (2 N•m) torque. Do not displace release lever wave washer when assembling shroud and housing.

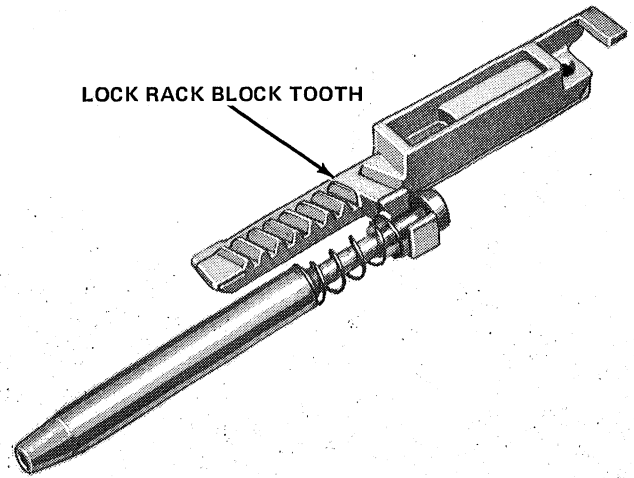

60673

Fig. 2J-18 Assembling Lock Bolt and Lock Rack

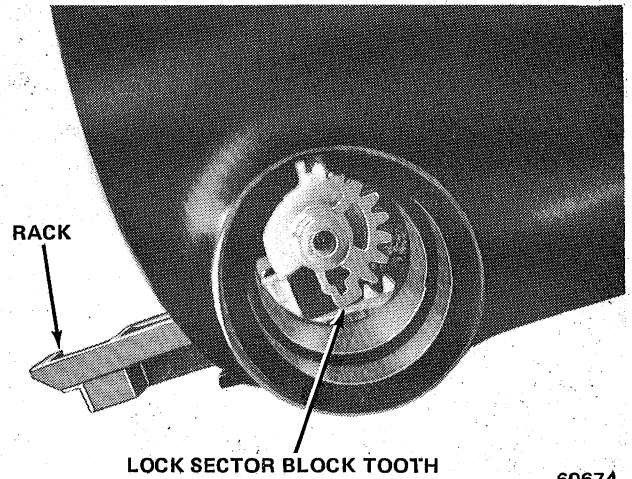

60674

Fig. 2J-19 Lock Bolt and Lock Rack Installation

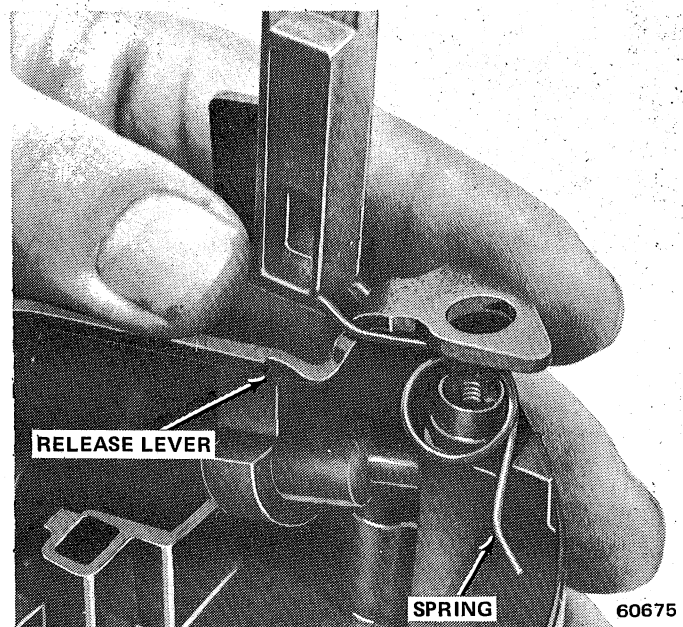

60675

Fig. 2J-20 Key Release Lever and Spring Installation

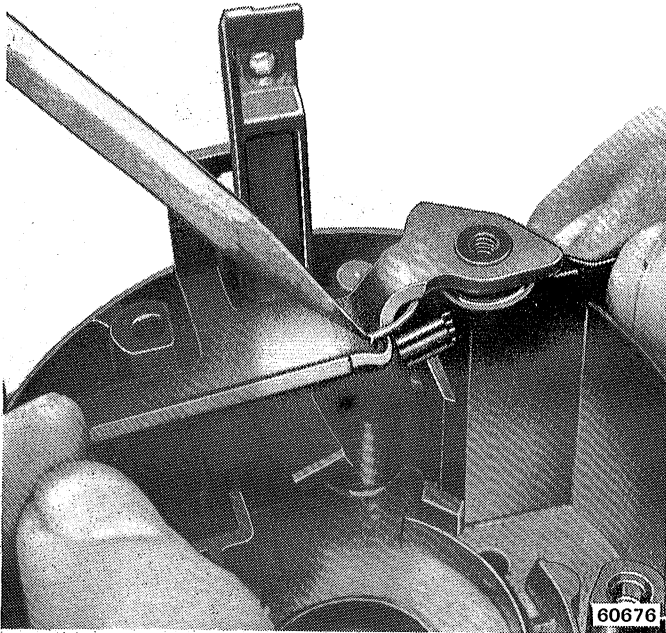

Fig. 2J-21 Positioning Key Release Lever Spring

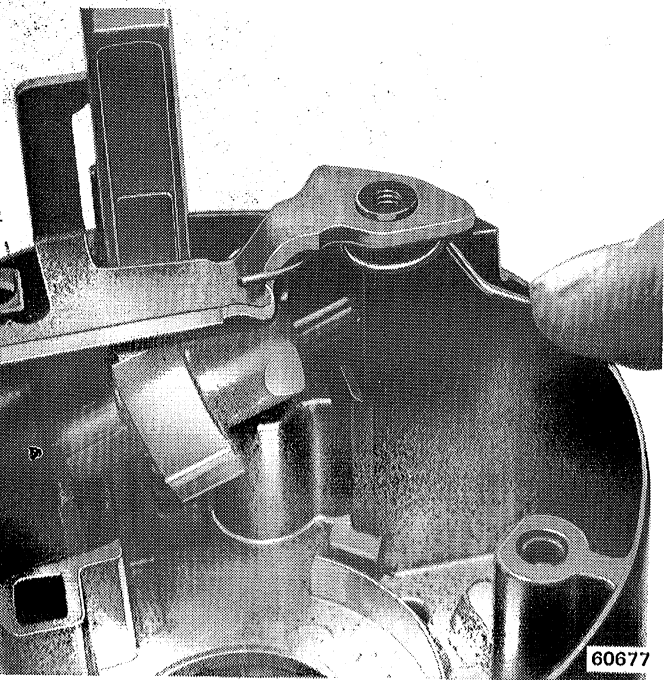

Fig. 2J-22 Securing Key Release Lever Spring

(10) Install remote rod on lock rack. Insert short hooked end of rod in lock rack.

(11) Install assembled shroud and housing on column and install attaching screws (fig. 2J-11). Tighten screws to 60 inch-pounds (7 N•m) torque.

(12) Install lock cylinder in lock cylinder sleeve. Insert key in lock, hold cylinder sleeve, and rotate key clockwise until key stops (this retracts actuator).

(13) Insert lock cylinder assembly in housing bore with cylinder tab aligned with keyway in housing. Push cylinder inward until it bottoms. Rotate key counterclockwise until drive section of cylinder mates with sector. Push cylinder in fully until tab engages in housing groove.

counterclockwise to Off-Unlock position.

(15) Install ignition switch as follows:

(a) Position switch on column jacket (fig. 2J-23).

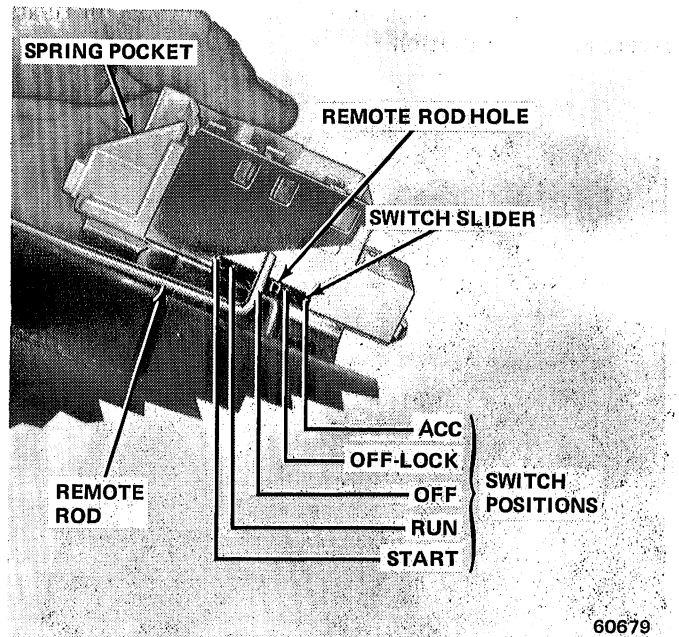

Fig. 2J-23 Positioning Ignition Switch

(b) Move switch slider to extreme left to Accessory position.

(c) Move slider two positions to right from Accessory position to Off-Unlock position.

(d) Insert remote rod into hole in switch slider.

(e) Position switch on column and install attaching screws. Tighten screws to 35 inch-pounds (4 N•m) torque.

(16) Install lower bearing, bearing adapter, retainer, and snap ring in lower end of column.

(17) Install steering shaft through lower end of column and into upper bearing in housing.

(18) Install turn signal switch and wire harness. Fold wires against connector and feed connector through housing and shroud.

(19) Align turn signal switch in housing and install switch attaching screws. Tighten screws to 35 inch-pounds (4 N•m) torque.

(20) On vehicles without Cruise Command, install turn signal lever. Tighten lever attaching screw to 35 inch-pounds (4 N•m) torque.

(21) On vehicles with Cruise Command, install lever and switch assembly. Use string previously taped in

place to guide wires into housing. Remove string and tape. Connect wires to switch terminal and install lever attaching screw. Tighten screw to 35 inch-pounds (4 N•m) torque.

(22) Install thrust washer, upper bearing preload spring, and canceling cam on steering shaft. Position canceling cam as shown in figure 2J-24.

(23) Place turn signal switch in neutral position and install hazard warning switch knob.

(24) Position lock plate on steering shaft.

(25) Install replacement steering shaft snap ring on sleeve of Compressor Tool J-23653 and install tool on steering shaft (fig. 2J-25).

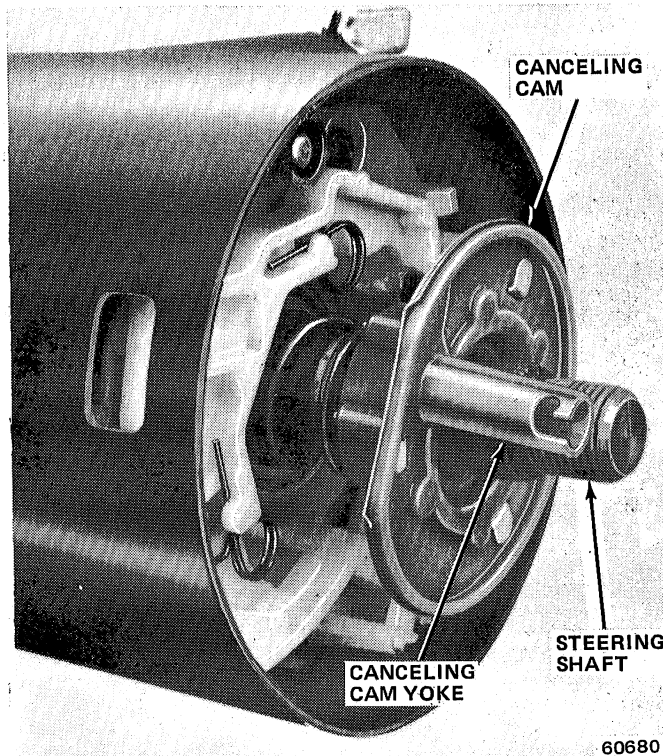

Fig. 2J-24 Positioning Canceling Cam

CAUTION: Identify the steering shaft nut thread type before using the compressor tool. If the shaft has American threads, use the compressor tool as is. However, if the shaft has metric threads (fig. 2J-2), replace the compressor tool forcing screw with Metric Forcing Screw J-23653-4 before using the tool.

(26) Compress lock plate and install snap ring in steering shaft groove (fig. 2J-25).

(27) Remove compressor tool. Be sure snap ring is fully seated before removing tool.

(28) Install lock plate cover.

(29) Remove Support Fixture Tool J-23074, if installed.

(30) Install column mounting bracket. Tighten bracket attaching bolts to 20 foot-pounds (27 N•m) torque.

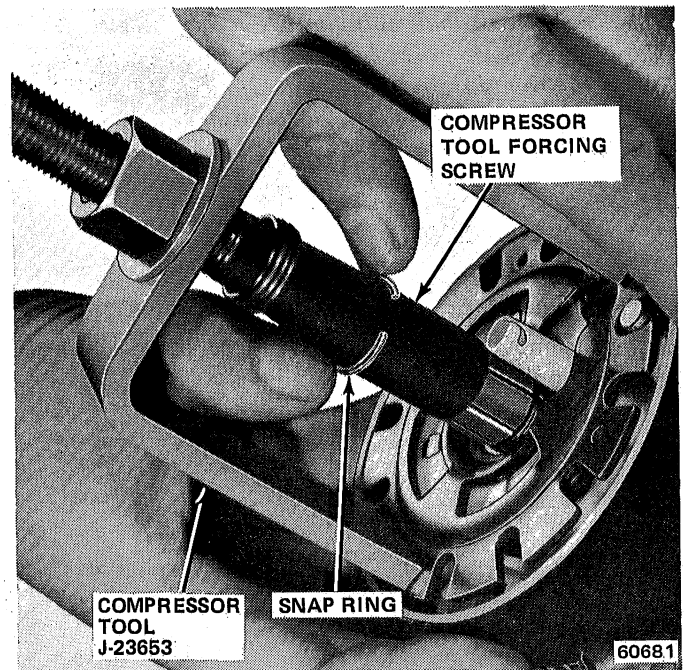

Fig. 2J-25 Steering Shaft Snap Ring Installation

(31) Connect column wiring harness connectors and install harness protector.

(32) Install steering wheel.

(33) Install and tighten steering wheel nut to 30 foot-pounds (41 N•m) torque.

CAUTION: Some steering shafts have metric size steering wheel nut threads. If a replacement nut is being installed, identify the shaft thread type before installation. Metric shafts have an identifying groove in the steering wheel locating splines (fig. 2J-2). American thread shafts do not have this groove.

(34) Install column bezel.

(35) Install and tighten column bracket-to-instrument panel bolts to 20 foot-pounds (27 N•m) torque.

(36) Tighten toe plate bolts to 10 foot-pounds (14 N•m) torque.

(37) Remove protective covering from column painted areas.

(38) Connect battery negative cable.

STANDARD COLUMN OVERHAUL—AUTOMATIC TRANSMISSION

Column Disassembly

NOTE: Steering column removal is not necessary if only the lock plate cover, lock plate, steering shaft snap ring, upper bearing preload spring, canceling cam, turn

signal switch, or lock cylinder are to be serviced. However, the column must be removed in order to service any of the remaining components. If the column must be removed, remove the column mounting bracket and install Support Fixture J-23074 (fig. 2J-5). Mount the column in a vise by clamping the support fixture flange in the vise.

- (1) Disconnect battery negative cable.
- (2) Place front wheels in straight-ahead position.
- (3) Remove column-to-instrument panel bezel and left air conditioning duct, if equipped.
- (4) Cover painted areas of column.

- (5) Remove steering wheel (fig. 2J-1).
- (6) Remove lock plate cover (fig. 2J-26). Use two screwdrivers to pry cover off lock plate and out of housing.

- (7) Compress lock plate and unseat steering shaft snap ring as follows:

(a) Inspect and identify steering shaft nut thread type. Metric shafts have identifying groove in steering wheel locating splines (fig. 2J-2). American thread shafts do not have this groove.

(b) If shaft has American threads, use Compressor Tool J-23653, as is, to compress lock plate and unseat snap ring (fig. 2J-6).

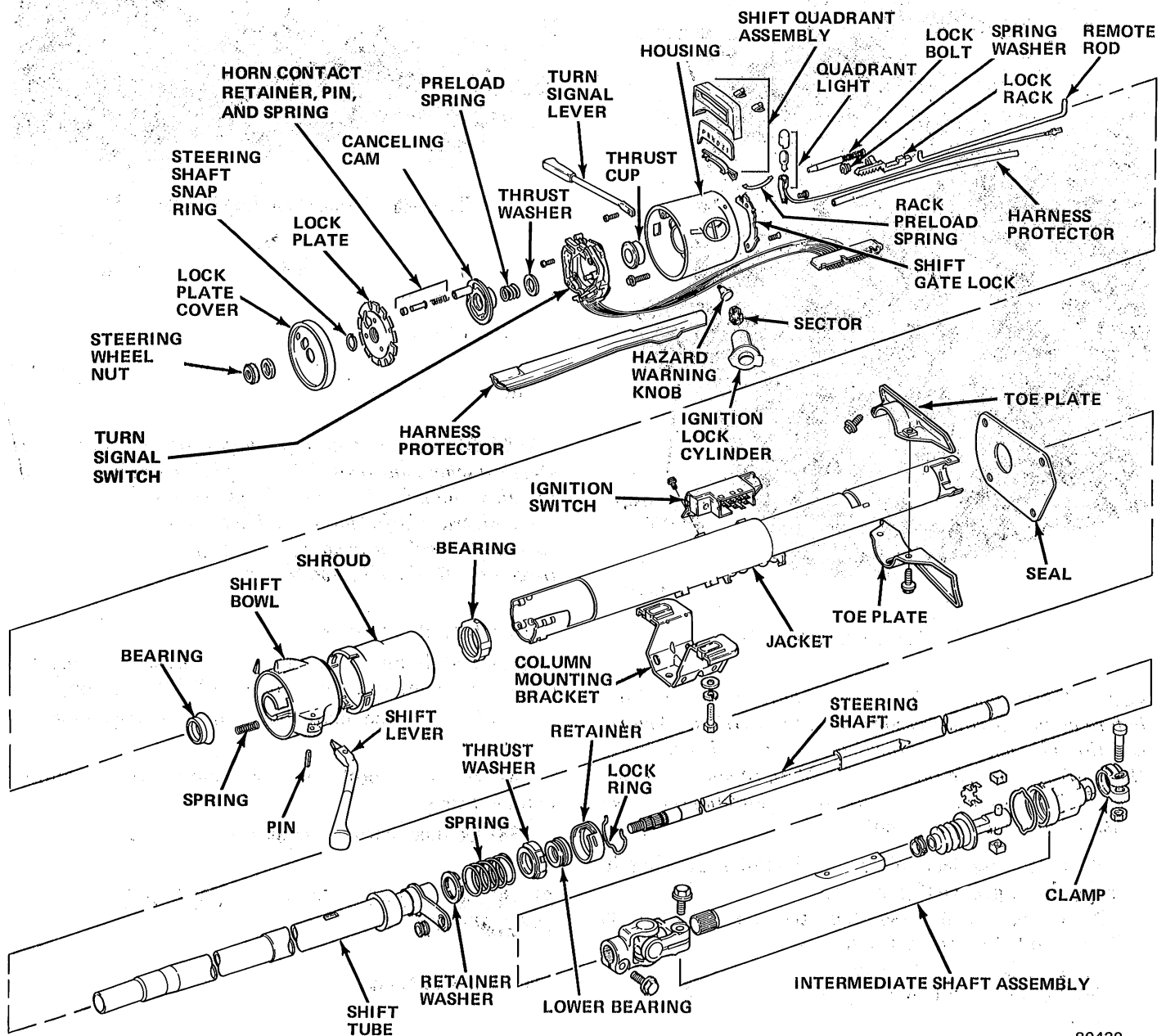

80438

Fig. 2J-26 Steering Column—Automatic Transmission

(c) If shaft has metric nut threads; replace compressor tool standard forcing screw with Metric Forcing Screw J-23653-4 before installing tool on steering shaft.

WARNING: The lock plate is under strong spring tension. Do not attempt to remove the snap ring without using the compressor tool.

(8) Remove lock plate compressor tool and remove steering shaft snap ring. Discard snap ring.

CAUTION: When the snap ring is removed, the steering shaft is free in the column. If the column is removed for bench overhaul, do not let the shaft fall out when the column is moved.

(9) Remove lock plate, canceling cam, upper bearing preload spring, and thrust washer (fig. 2J-26).

(10) On vehicles without Cruise Command, remove turn signal lever attaching screw and remove lever.

(11) On vehicles with Cruise Command, remove wires from switch terminal. Fold two of four wires back along harness. Tape wires in place and tape length of string to harness to aid removal.

(12) Push inward on hazard warning switch knob and unthread knob in counterclockwise direction.

(13) Place gearshift lever in Park position. Remove lever retaining pin using punch and remove lever.

(14) Unhook turn signal switch wire harness connector from column.

(15) Disconnect turn signal switch harness connector from instrument panel harness connector (fig. 2J-7). Lift connector lock tab to separate connectors.

(16) Using stiff wire or paper clip, compress lock tab retaining shift quadrant light wire in connector block and disconnect wire.

(17) Remove column lower bracket and plastic harness protector.

(18) Remove column-to-instrument panel mounting bracket if turn signal switch is to be removed with column mounted in vehicle.



Fig. 2J-27 Turn Signal Switch Harness Removal

(19) Wrap tape around turn signal switch harness connector to prevent snagging (fig. 2J-27).

(20) Remove turn signal switch attaching screws and remove switch and harness. Pull switch straight up and out of column.

(21) On vehicles with Cruise Command, remove turn signal lever attaching screw and remove lever and switch as assembly. Guide switch harness out of column using string previously taped to harness.

(22) Place lock cylinder in LOCK position. Compress lock cylinder retaining tab and remove lock cylinder (fig. 2J-9).

NOTE: The retaining tab is accessible through the tab slot in the housing (fig. 2J-9). If the tab is not visible through the slot, scrape or knock all casting flash from the slot.

(23) Remove ignition switch from lower end of column.

(24) Remove upper housing attaching screws and remove upper housing.

NOTE: The remote rod and shift quadrant light wire, if equipped, will be removed as an assembly along with the upper housing.

(25) Remove thrust cup from upper housing (fig. 2J-28).

(26) Remove lock bolt and lock rack and remove rack preload spring (fig. 2J-29).

(27) Remove lock sector from sector shaft using blunt punch (fig. 2J-19). Note lock sector position for assembly reference and remove sector through lock cylinder hole in housing.

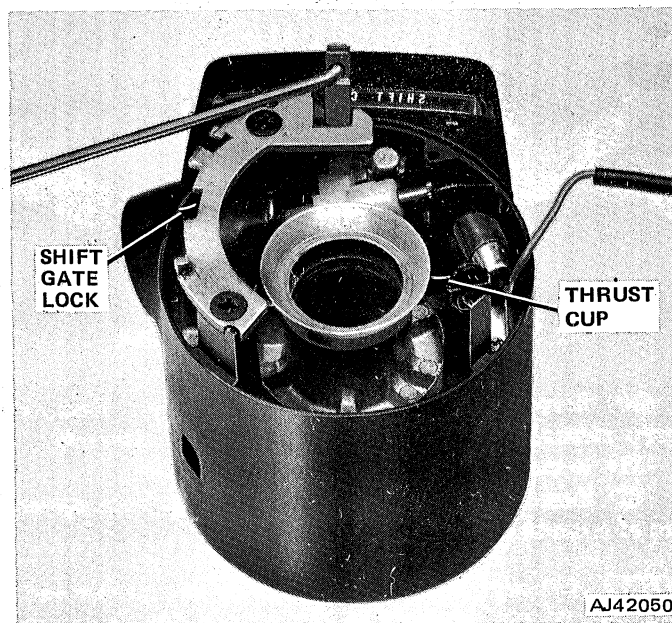

Fig. 2J-28 Thrust Cup Position

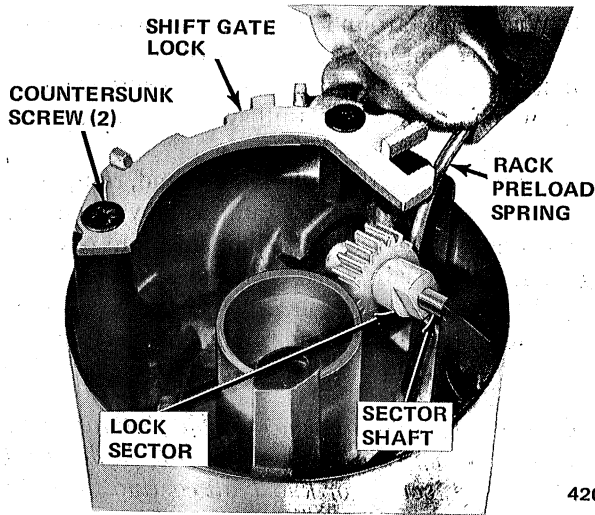

Fig. 2J-29 Housing Components

(28) Remove shift gate lock from upper housing. Examine shift gate lock detents for wear. Replace lock if excessively worn.

(29) Remove shift quadrant. Quadrant is retained by two clips which must be pried out with small punch (fig. 2J-30).

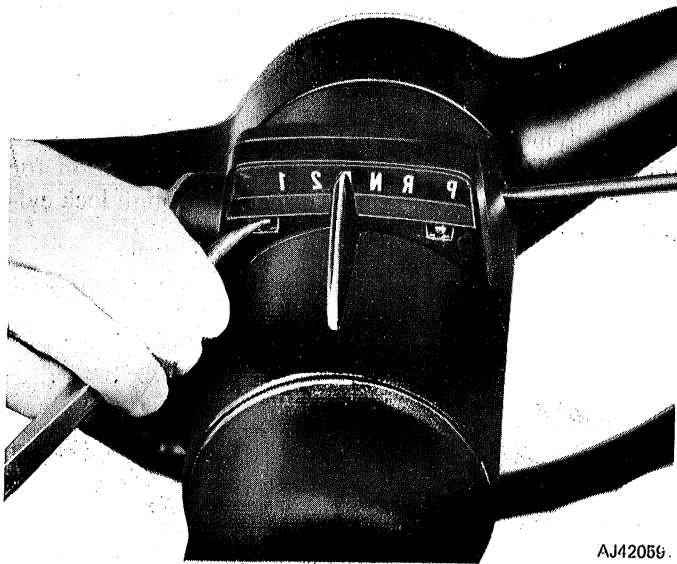

Fig. 2J-30 Shift Quadrant Retainer Clip Removal

(30) Remove shift quadrant light cover. Remove screw retaining socket assembly and remove assembly.

(31) Remove shift bowl from column jacket.

(32) Remove nylon lower bowl bearing from upper end of column tube (fig. 2J-31).

NOTE: Although the preceding steps are performed with the column mounted in the vehicle, the following steps can be performed only after the column has been removed.

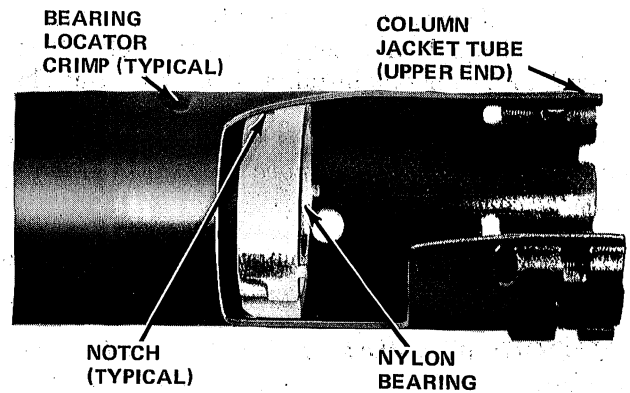
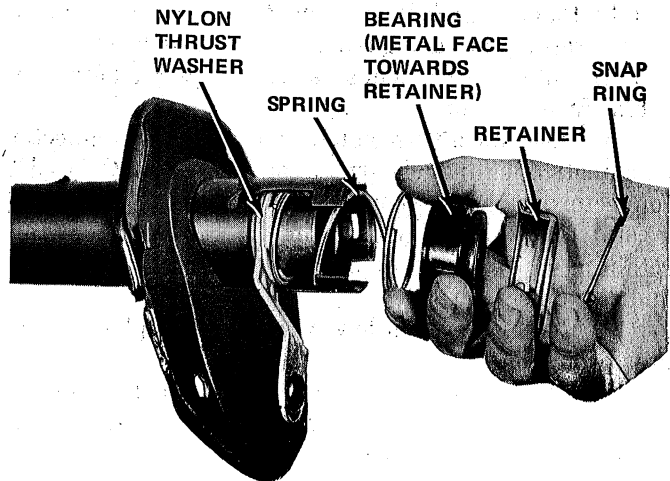

Fig. 2J-31 Shift Bowl Lower Bearing Position

(33) Remove column from vehicle. Refer to Steering Column Removal.

(34) Remove steering shaft from lower end of column.

(35) Remove lower bearing retainer, retainer ring, lower bearing preload spring, and nylon washer (fig. 2J-32).



NOTE: FLOOR SHIFT STEERING COLUMNS HAVE NO THRUST WASHER OR SPRING

Fig. 2J-32 Lower Bearing Assembly

(36) Remove shift tube.

(37) Remove nylon shift tube bearing from tube.

Column Assembly

(1) Apply chassis grease to all friction and bearing surfaces.

(2) Install shift tube.

(3) Install nylon washer in lower end of shift tube with flat side of washer facing upper end of tube (fig. 2J-32).

(4) Install preload spring, lower bearing (with metal face toward retainer), bearing retainer, and retainer ring.

(5) Install nylon lower bowl bearing in upper end of jacket.

NOTE: The bearing must be installed with the smaller inside diameter facing the lower end of the jacket, and with the bearing notches engaged in the three locator crimps in the column (fig. 2J-31).

(6) Align shift bowl with shift tube spline and install bowl.

(7) Install rack preload spring in upper housing (fig. 2J-29).

(8) Position large end of sector on sector shaft and press sector in place using blunt punch (fig. 2J-17).

(9) Install shift gate lock and install two countersunk attaching screws (fig. 2J-28). Tighten screws to 45 inch-pounds (5 N•m) torque.

(10) Install shift quadrant lamp and lamp cover.

(11) Install shift quadrant indicator and press retainer clips into place with flat side toward bowl.

(12) Assemble lock bolt and lock rack (fig. 2J-18).

(13) Install assembled lock bolt and lock rack in shift bowl (fig. 2J-33).

NOTE: The block tooth of the lock rack must engage the block tooth of the sector (fig. 2J-19).

(14) Install nylon thrust cup in upper housing with flared end of cup facing outward (fig. 2J-28).

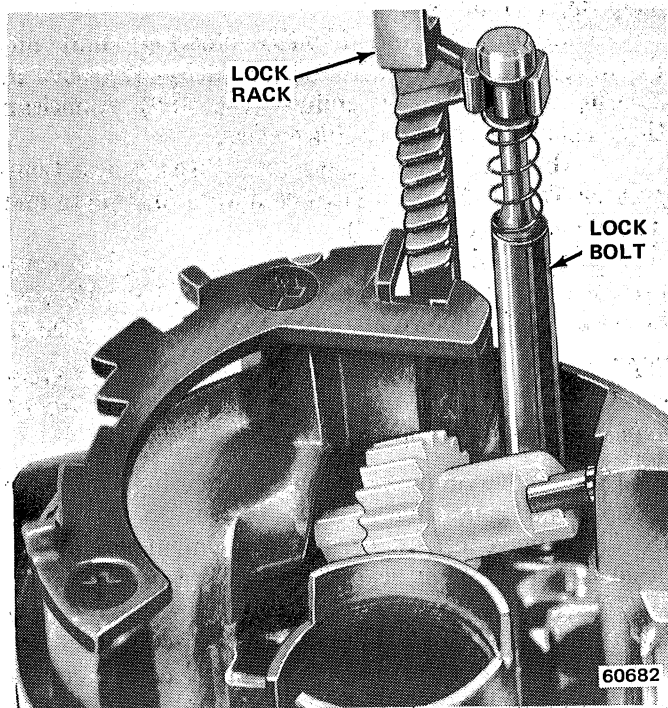

Fig. 2J-33 Lock Rack and Lock Bolt Installation

(15) Rotate shift bowl counterclockwise to stop and install upper housing. Tighten housing attaching screws to 60 inch-pounds (7 N•m) torque.

NOTE: The shift bowl must be in the Park position and the rack pulled downward before the upper housing can be installed.

(16) Guide shift quadrant lamp wire and remote lock rod into position between shift bowl and column jacket.

(17) Install turn signal switch and harness assembly in column.

(18) Remove tape from turn signal switch wire harness connector and position harness in protector and protector-to-column jacket.

(19) Install turn signal switch retaining screws. Be sure switch actuating lever pivot is correctly aligned and seated in upper housing pivot boss before installing screws.

(20) On vehicles without Cruise Command, install turn signal lever and lever attaching screw. Tighten screw to 35 inch-pounds (4 N•m) torque.

(21) On vehicles with Cruise Command, install turn signal lever and switch assembly. Guide wires into housing using string previously taped in place. Remove string and tape. Connect wires to switch terminals. Install lever attaching screw and tighten screw to 35 inch-pounds (4 N•m) torque.

(22) Install steering shaft, if removed. Install shaft through lower end of column and into upper bearing.

(23) Install thrust washer, upper bearing preload spring, and canceling cam on upper end of steering shaft.

(24) Align lock plate splines with steering shaft splines and install lock plate. Be sure canceling cam shaft protrudes through opening in lock plate (fig. 2J-34).

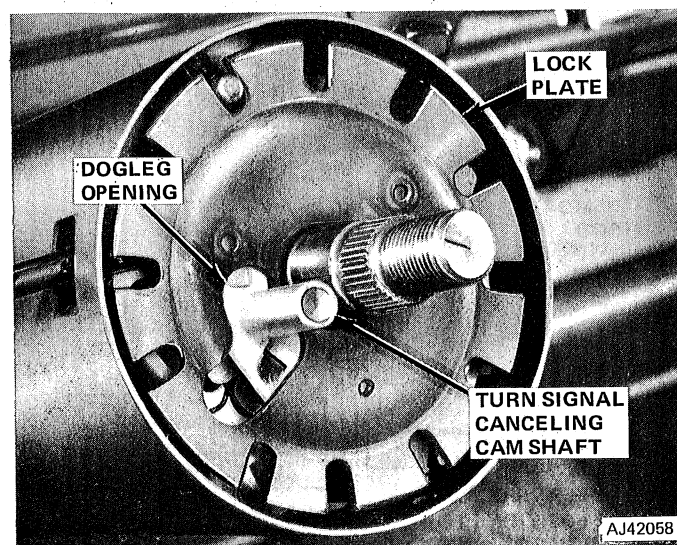

Fig. 2J-34 Cancelling Cam and Lock Plate Position

(25) Install replacement steering shaft snap ring on sleeve of Lock Plate Compressor Tool J-23653 and install tool on steering shaft (fig. 2J-25).

CAUTION: *Inspect and identify the steering shaft nut thread type before installing the compressor tool. If the shaft has metric threads (fig. 2J-2), be sure to replace the compressor tool standard forcing screw with Metric Forcing Screw J-23653-4 before installing the tool on the shaft.*

(26) Compress lock plate and seat snap ring in steering shaft groove.

(27) Remove compressor tool.

(28) Install lock plate cover.

(29) Align canceling cam and index marks on steering shaft and steering wheel and install steering wheel. Tighten steering wheel nut to 30 foot-pounds (41 N•m) torque.

CAUTION: *Some steering shafts have metric threads. Be sure to obtain and install the proper thread-type nut. Metric thread shafts have an identifying groove in the steering wheel locating splines (fig. 2J-2).*

(30) Install hazard warning light switch knob and steering wheel trim cover.

(31) Install gearshift lever.

(32) Install lock cylinder in housing.

(33) Place shift bowl in any position except Park and rotate bowl counterclockwise until lock rack bottoms against lower surface of bowl.

(34) Install ignition switch on column:

(a) Move switch slider toward left to Accessory position.

(b) Move slider two positions toward right to Off-Unlock position (fig. 2J-35).

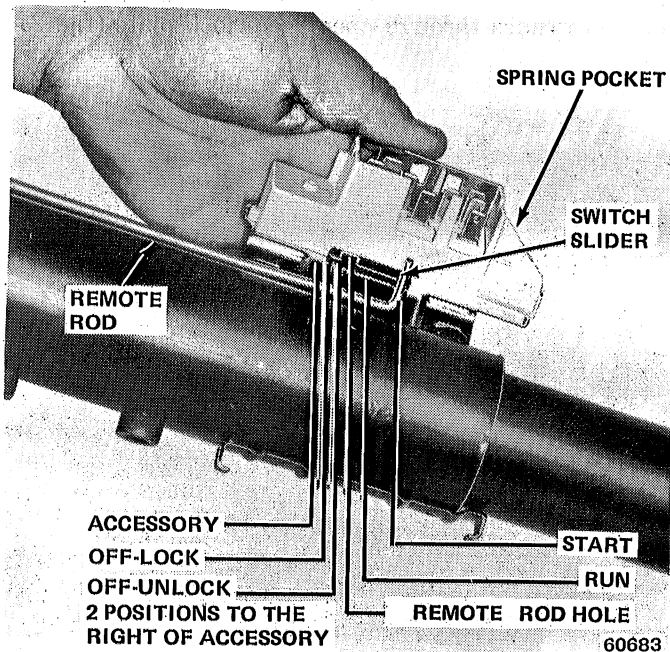

Fig. 2J-35 Positioning Ignition Switch

(c) Insert remote rod into slider hole and attach ignition switch to column. Tighten switch attaching screws to 35 inch-pounds (4 N•m) torque.

(35) Install column if removed. Refer to Steering Column Installation.

(36) Install lower finish panel, air conditioning duct if equipped, and column-to-instrument panel bezel.

(37) Remove protective covering from painted areas of column.

(38) Connect battery negative cable.

TILT COLUMN OVERHAUL—CHEROKEE-WAGONEER-TRUCK MODELS

Column Disassembly

NOTE: *Although it is possible to disassemble the tilt steering column down to the housing with the column in the vehicle, the column must be removed if more extensive disassembly is necessary. If the column is removed, use Steering Column Support Fixture J-23074 to mount the column assembly in a vise (fig. 2J-5).*

(1) Place front wheels in straight-ahead position.

(2) Disconnect battery negative cable.

(3) Cover painted areas of column.

(4) Remove steering wheel.

(5) Remove gearshift lever retaining pin and remove gearshift lever.

(6) Remove lock plate cover. Use two screwdrivers to pry cover off lock plate and out of housing.

(7) Compress lock plate and unseat steering shaft snap ring as follows:

(a) Inspect and identify steering shaft nut thread type. Metric shafts have identifying groove in steering wheel locating splines (fig. 2J-2). American thread shafts do not have this groove.

(b) If shaft has American threads, use Compressor Tool J-23653 as is to compress lock plate and unseat snap ring (fig. 2J-6).

(c) If shaft has metric threads, replace compressor tool standard forcing screw with Metric Forcing Screw J-23653-4 before installing tool on steering shaft.

WARNING: *The lock plate is under strong spring pressure. Do not attempt to remove the lock plate without using the compressor tool.*

(8) Remove compressor tool and steering shaft snap ring. Discard snap ring.

(9) Remove lock plate, canceling cam, upper bearing preload spring, spring seat, and bearing race.

(10) On vehicles without Cruise Command, remove turn signal lever attaching screw and remove lever.

(11) On vehicles with Cruise Command, remove wires from switch terminal in lever. Fold two of four switch wires back, along harness and tape wires in place. Tape length of string to harness to aid removal.

(12) Press hazard warning light switch knob inward and remove knob by turning counterclockwise.

(13) Unhook turn signal switch wire harness connector from mounting bracket on lower right side of column jacket.

(14) Loosen toeplate bolts.

(15) Remove bolts attaching column mounting bracket to steering column.

(16) Remove bolts attaching mounting bracket to instrument panel and remove mounting bracket.

(17) Remove wire harness plastic protector from column jacket.

(18) Wrap tape around harness connector to prevent snagging (fig. 2J-27).

(19) Remove turn signal switch retaining screws and remove switch and wire harness. Pull switch straight up and out of column.

(20) On vehicles with Cruise Command, remove turn signal lever attaching screw and remove lever and switch. Guide switch wire harness out of column using string previously taped to harness.

(21) Insert ignition key in lock cylinder and turn cylinder to LOCK position.

(22) Compress lock cylinder retaining tab and remove lock cylinder (fig. 2J-9).

NOTE: The retaining tab is accessible through the tab slot in the housing (fig. 2J-9). If the tab is not visible through the slot, remove all casting flash from the slot.

(23) Remove spring clips retaining shift quadrant using punch or long needlenose pliers and remove quadrant (fig. 2J-30).

(24) Remove shift quadrant mounting bracket and light socket.

(25) Remove tilt lever.

(26) Remove cover retaining screws and remove cover from column.

(27) Remove lock sector tension spring retaining screw. Unhook spring from lock sector shaft and remove spring.

(28) Remove snap ring from lock sector shaft and remove lock sector, sector shaft, and retaining ring.

(29) Install tilt lever and place upper housing in full upward tilt position.

(30) Insert screwdriver in tilt spring retainer slot and compress retainer approximately 3/16 inch (4.7 mm). Rotate retainer 1/8 turn counterclockwise and remove retainer and spring.

WARNING: The tilt spring is under strong spring tension.

(31) Place housing in center (nontilt) position.

(32) Remove housing pivot pins using tool J-21854-1 (fig. 2J-36).

(33) Lift tilt lever to disengage lock shoes and remove housing. Remove both ball bearing assemblies from housing if bearings are to be replaced.

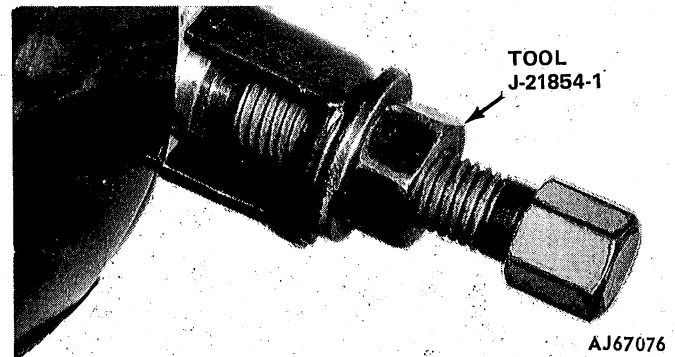

Fig. 2J-36 Pivot Pin Removal

(34) Remove tilt lever.

(35) Remove release lever pin from housing using pin punch or tool J-22635 (fig. 2J-37).

NOTE: When removing the release lever pin, compress the lock shoe springs to relieve spring tension on the pin.

(36) Remove lock shoe pin from housing using pin punch or tool J-22635 (fig. 2J-38).

NOTE: When removing the lock shoe pin, compress the lock shoe springs to relieve spring tension on the pin (fig. 2J-38).

(37) Remove lock shoes and lock shoe springs.

(38) Disconnect steering shaft at intermediate shaft coupling. Remove steering shaft through upper end of column.

(39) Disassemble steering shaft by folding shaft at 90° and separating upper and lower halves of shaft at flexible joint (fig. 2J-39).

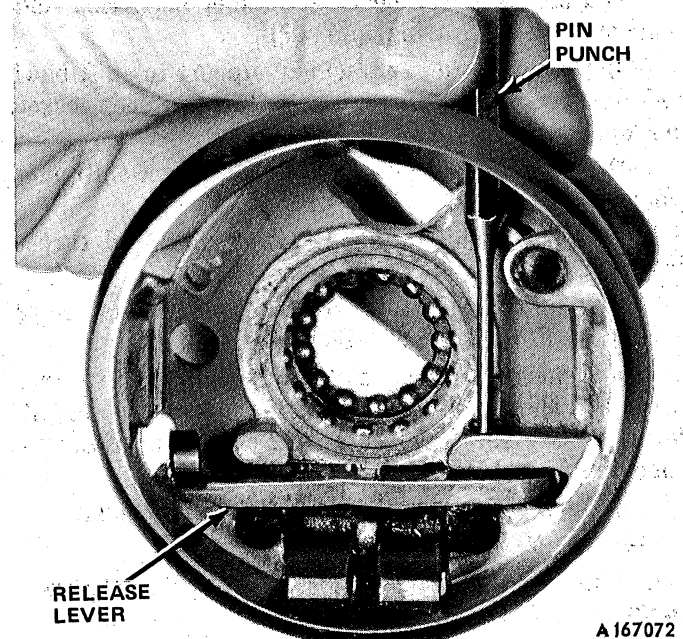

Fig. 2J-37 Release Lever Pin Removal

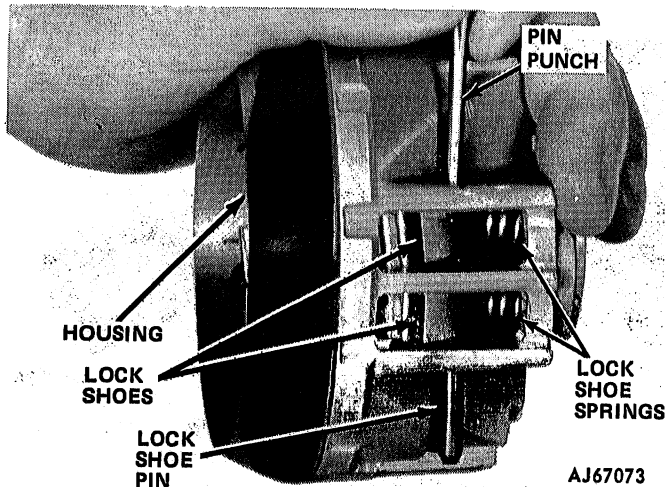

Fig. 2J-38 Lock Shoe Pin Removal

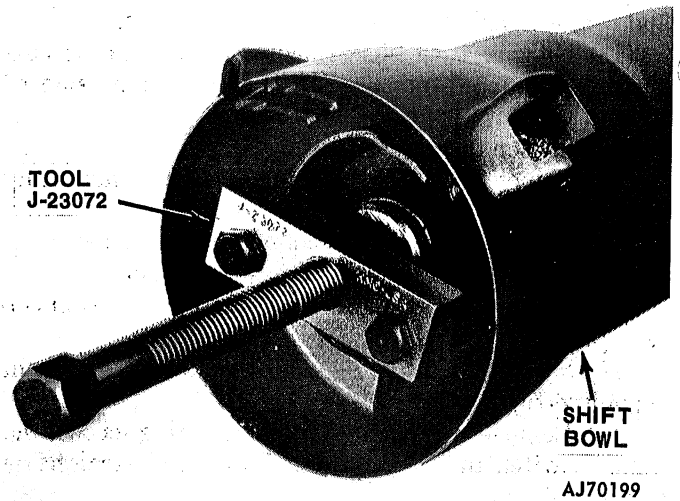

Fig. 2J-40 Shift Tube Removal

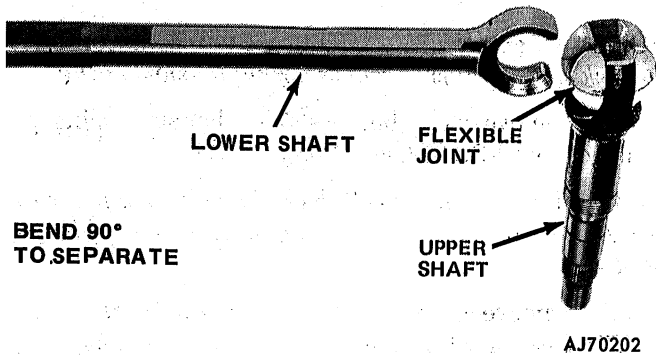

Fig. 2J-39 Steering Shaft Assembly

- (40) Remove ignition switch.
- (41) Remove lock rack and remote rod.
- (42) Remove lower bearing retainer snap ring and remove retainer, bearing, and adapter.
- (43) Remove screws attaching support to shift bowl and remove support. Use 1/4-inch, 12-point deep socket to remove screws.
- (44) Remove shift gate screws and remove shift gate from support.
- (45) Remove shift tube retaining ring and thrust washer.
- (46) Remove shift tube from column jacket using Shift Tube Remover Tool J-23072 (fig. 2J-40).
- (47) Remove retainer plate by rotating shift bowl clockwise, sliding plate out of jacket notches, tipping it down toward shift bowl hub at 12 o'clock position and removing plate-bottom side first (fig. 2J-41).
- (48) Remove wave washer and shift tube spring.
- (49) Remove shift bowl from column jacket.
- (50) Remove lower bearing retainer spring clip (fig. 2J-42).
- (51) Remove lower bearing retainer and remove lower bearing, and bearing adaptor assembly.

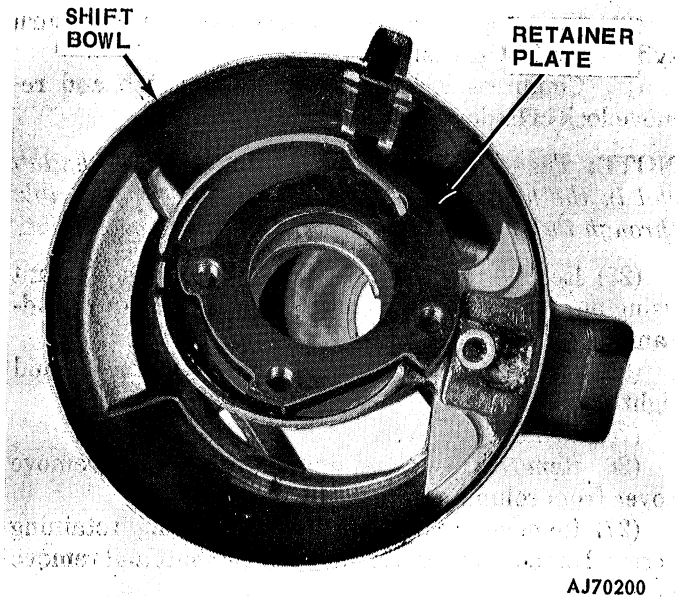

Fig. 2J-41 Retainer Plate Removal

Column Assembly

- (1) Coat all bearing and friction surfaces with chassis grease.
- (2) Mount shift bowl on column jacket.
- (3) Install shift tube spring, wave washer, and retainer plate in shift bowl.
- (4) Install shift tube through lower end of column jacket and align tube spline with shift bowl keyway.
- (5) Insert Installer Tools J-23073-2 and -4 in shift tube (fig. 2J-43). Spring-loaded lower foot of tool must engage shift tube inner shoulder and tool guide must be seated in shift tube.
- (6) Tighten tool spring tension nut to snug fit.

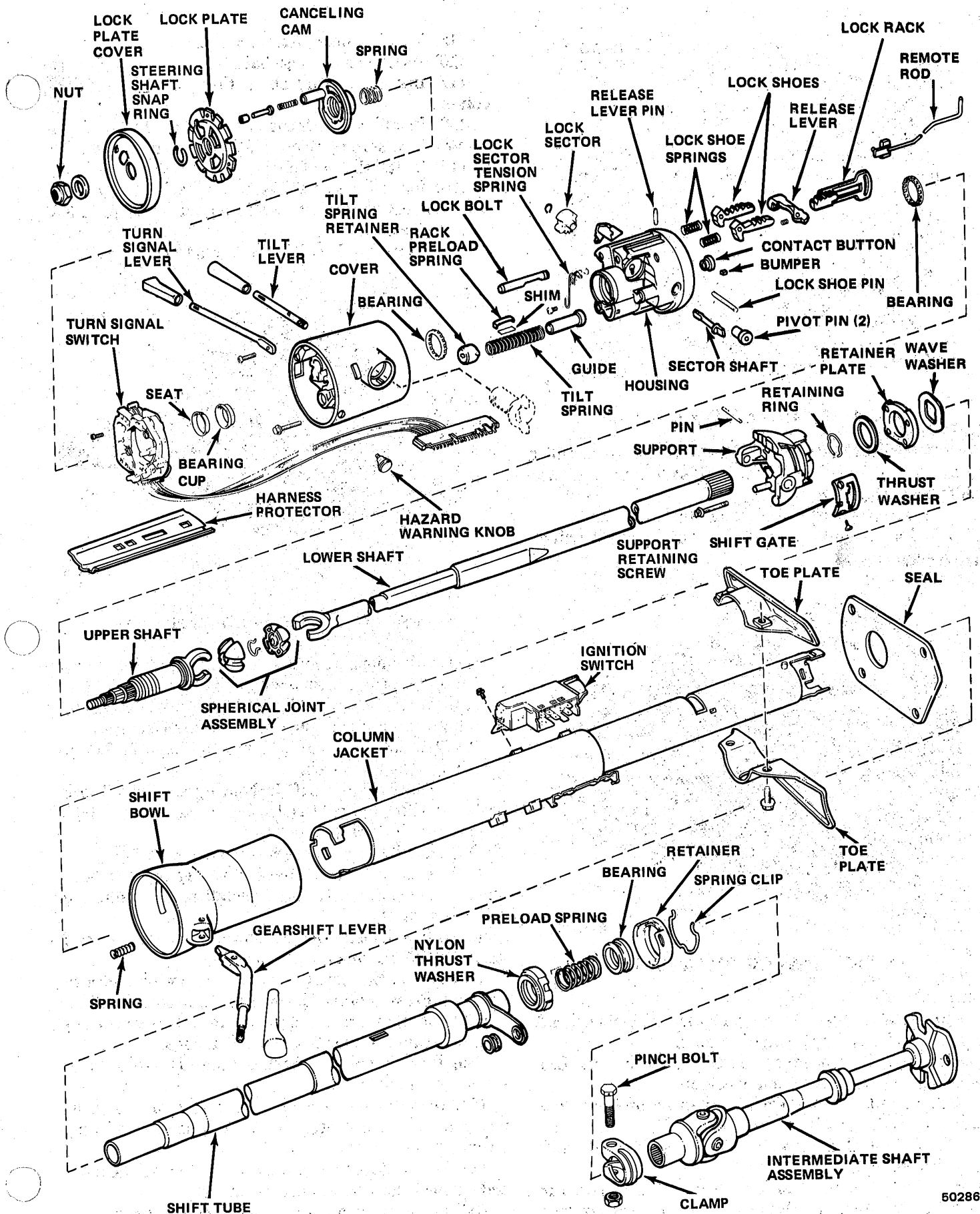

Fig. 2J-42 Tilt Steering Column—Cherokee-Wagoneer-Truck Models

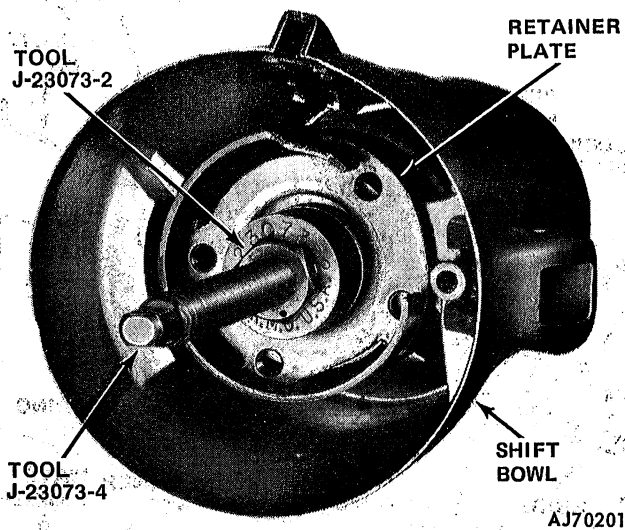

Fig. 2J-43 Positioning Shift Tube Installer Tools

- (7) Place Receiver Tools J-23073-3 and -4 over puller stud and tighten Tool Nut J-23073-2 to pull tube into shift bowl (fig. 2J-44).
- (8) Remove shift tube installer tools.
- (9) Install shift tube thrust washer and retainer plate snap ring.

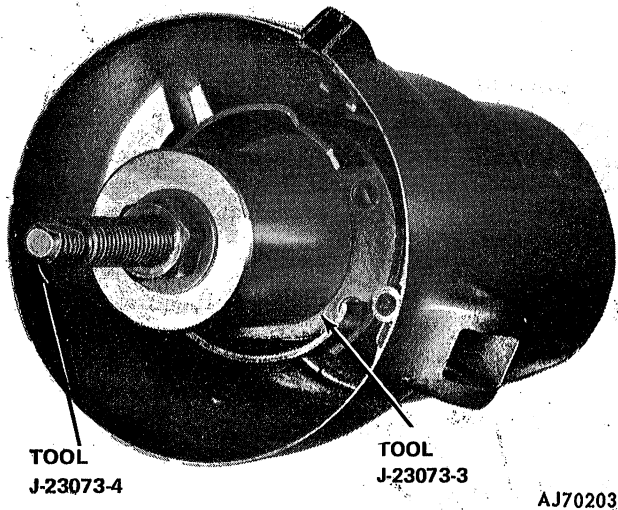

Fig. 2J-44 Pulling Shift Tube Into Shift Bowl

- (10) Install lower bearing adaptor with notched end of adaptor facing lower end of column.
- (11) Install lower bearing in column with metal face of bearing toward lower end of column.
- (12) Install lower bearing retainer and retainer spring clip (fig. 2J-42).
- (13) Install shift gate in support and install shift gate attaching screws.
- (14) Install support in shift bowl. Align V-notch in support with notch in column jacket (located at 9 o'clock position).

- (15) Install support attaching screws.
- (16) Assemble steering shaft.
- (17) Install steering shaft through upper end of column.
- (18) Install replacement ball bearings in housing if removed. Be sure there are 14 balls in each bearing.
- (19) Install tilt handle.
- (20) Insert ignition switch remote rod between shift-bowl and column jacket, and into guide channel in left side of support.
- (21) Engage lock rack in remote rod (fig. 2J-45).

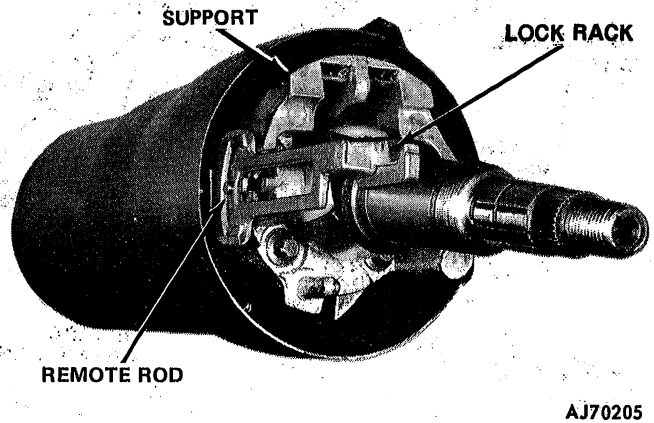

Fig. 2J-45 Lock Rack and Remote Rod Position

- (22) Guide housing over steering shaft and lock rack and align lock shoes with teeth in support.
- (23) Align housing and support pivot pin holes and install pivot pins using fiber mallet or brass drift.
- (24) Install lock shoes, lock shoe springs, tilt bumpers, and lockpin in housing.
- (25) Install sector shaft in housing and install lock sector on shaft. Large block tooth on sector must engage large slot in lock rack.
- (26) Install lock sector retaining snap ring.
- (27) Hook lock sector tension spring on lock bolt, engage spring in sector, and install spring retaining screw (fig. 2J-46).
- (28) Place housing in full upward tilt position and install tilt spring and guide in housing.
- (29) Install tilt spring retainer over spring and into housing. Press retainer downward approximately 3/16 inch (4.7 mm) and rotate approximately 1/8-turn clockwise to secure retainer tabs in housing lugs.
- (30) Place housing in neutral (nontilt) position and remove tilt handle.
- (31) Install cover on housing and install cover attaching screws. Tighten screws to 35 inch-pounds (4 N•m) torque.
- (32) Guide shift quadrant light wire through housing and between shift bowl and column jacket.
- (33) Install shift quadrant mounting bracket and attach light socket.

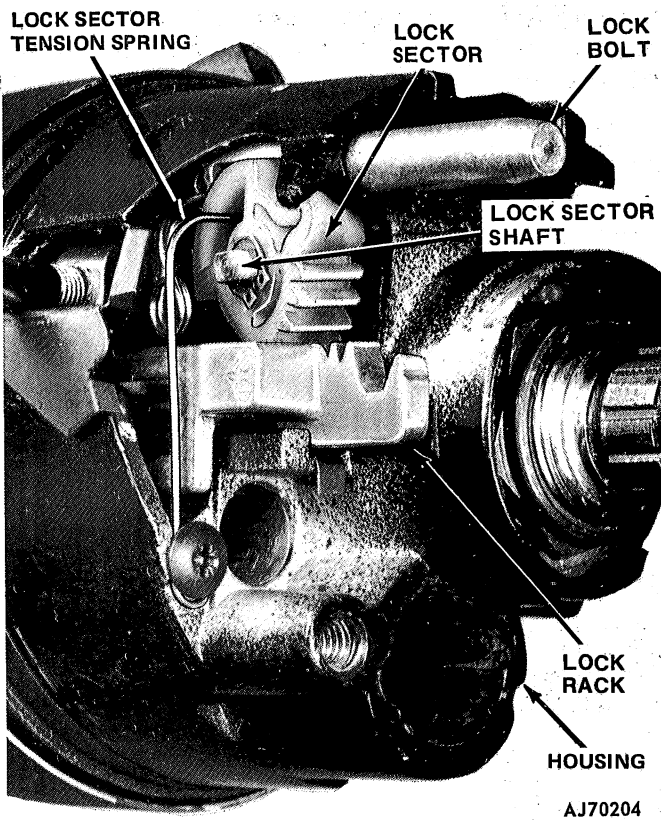

Fig. 2J-46 Lock Sector and Tension Spring Position

(34) Hook base of shift quadrant over tabs on left side of retainer and place in position.

(35) Install shift quadrant pointer in shift bowl and engage pointer in quadrant.

(36) Install quadrant retainer clips so flat side of clips face downward.

(37) Reinstall tilt handle.

(38) Install turn signal switch and switch harness in column. Guide switch wire harness between cover and column jacket.

(39) On vehicles without Cruise Command, install turn signal lever and lever attaching screw. Tighten screw to 35 inch-pounds (4 N•m) torque.

(40) On vehicles with Cruise Command, install turn signal lever and switch assembly. Guide switch wire harness into cover using string previously taped to harness. Remove tape from harness and connect wires to switch terminal. Install lever attaching screw and tighten screw to 35 inch-pounds (4 N•m) torque.

(41) Remove tape from turn signal switch harness connector and position wires in column harness protector.

(42) Align turn signal switch in cover and install switch attaching screws. Tighten screws to 35 inch-pounds (4 N•m) torque.

NOTE: Be sure the switch actuating lever pivot is correctly aligned and seated in the housing pivot boss before installing the switch attaching screws.

(43) Install mounting bracket on column. Tighten bracket-to-column bolts to 20 foot-pounds (27 N•m) torque.

(44) Position column mounting bracket on instrument panel and install bracket-to-instrument panel attaching bolts. Tighten bolts to 20 foot-pounds (27 N•m) torque.

(45) Tighten toeplate bolts to 10 foot-pounds (14 N•m) torque.

(46) Install upper bearing race, bearing seat, preload spring, and canceling cam on steering shaft.

(47) Align lock plate splines with steering shaft splines and install lock plate. Canceling cam shaft must protrude through opening in lock plate (fig. 2J-34).

(48) Install replacement steering shaft snap ring on sleeve of Compressor Tool J-23653 and install tool on steering shaft (fig. 2J-25).

CAUTION: Identify the steering shaft nut thread type before installing the compressor tool on the shaft. If the shaft has American threads, use the compressor tool as is. However, if the shaft has metric threads (fig. 2J-2), replace the compressor tool standard forcing screw with Metric Forcing Screw J-23653-4 before using the tool.

(49) Compress lock plate and seat snap ring in steering shaft groove (fig. 2J-25).

(50) Connect steering shaft to intermediate shaft coupling.

(51) Install gearshift lever in shift bowl. Guide lever over lock sector tension spring and into bowl. Align lever retaining pin holes with pin punch and install retaining pin using fiber mallet or brass drift.

(52) Install lock cylinder as follows:

(a) Insert ignition key in lock cylinder.

(b) Hold lock cylinder and turn key clockwise until it stops.

(c) Align cylinder retainer tab with keyway in cover and insert cylinder in cover.

(d) Push lock cylinder against lock sector. Rotate cylinder counterclockwise until cylinder engages in sector and push cylinder inward until cylinder retainer tab snaps into place.

(53) Install steering wheel. Tighten steering wheel nut to 30 foot-pounds (41 N•m) torque.

CAUTION: Some steering shafts have metric size steering wheel nut threads. Be sure to install the proper thread-type nut. Metric shafts have an identifying groove in the steering wheel locating splines (fig. 2J-2). Shafts with American threads do not have this groove.

(54) Install column, if removed. Refer to Steering Column Installation. However, if column was serviced in vehicle, proceed to following steps.

(55) Install and tighten column mounting bracket bolts to 20 foot-pounds (27 N•m) torque.

(56) Position column mounting bracket on instrument panel and install panel-to-bracket nuts. Tighten nuts to 20 foot-pounds (27 N•m) torque.

TILT COLUMN OVERHAUL—CJ AND SCRAMBLER MODELS

NOTE: Although the tilt column (fig. 2J-47) can be disassembled down to the housing with the column mounted in the vehicle, the column must be removed if

- (57) Install column bezel.
- (58) Tighten toeplate screws to 10 foot-pounds (14 N•m) torque.
- (59) Remove protective covering from column painted areas.
- (60) Connect battery negative cable.

disassembly is to be more extensive. If the column is removed, use Support Fixture J-23074 to mount the column in a vise for service operations (fig. 2J-5).

Column Disassembly

- (1) Place front wheels in straight-ahead position.
- (2) Disconnect battery negative cable.
- (3) Cover painted areas of column.
- (4) Remove steering wheel.
- (5) Remove gearshift lever retaining pin and remove lever, if equipped.

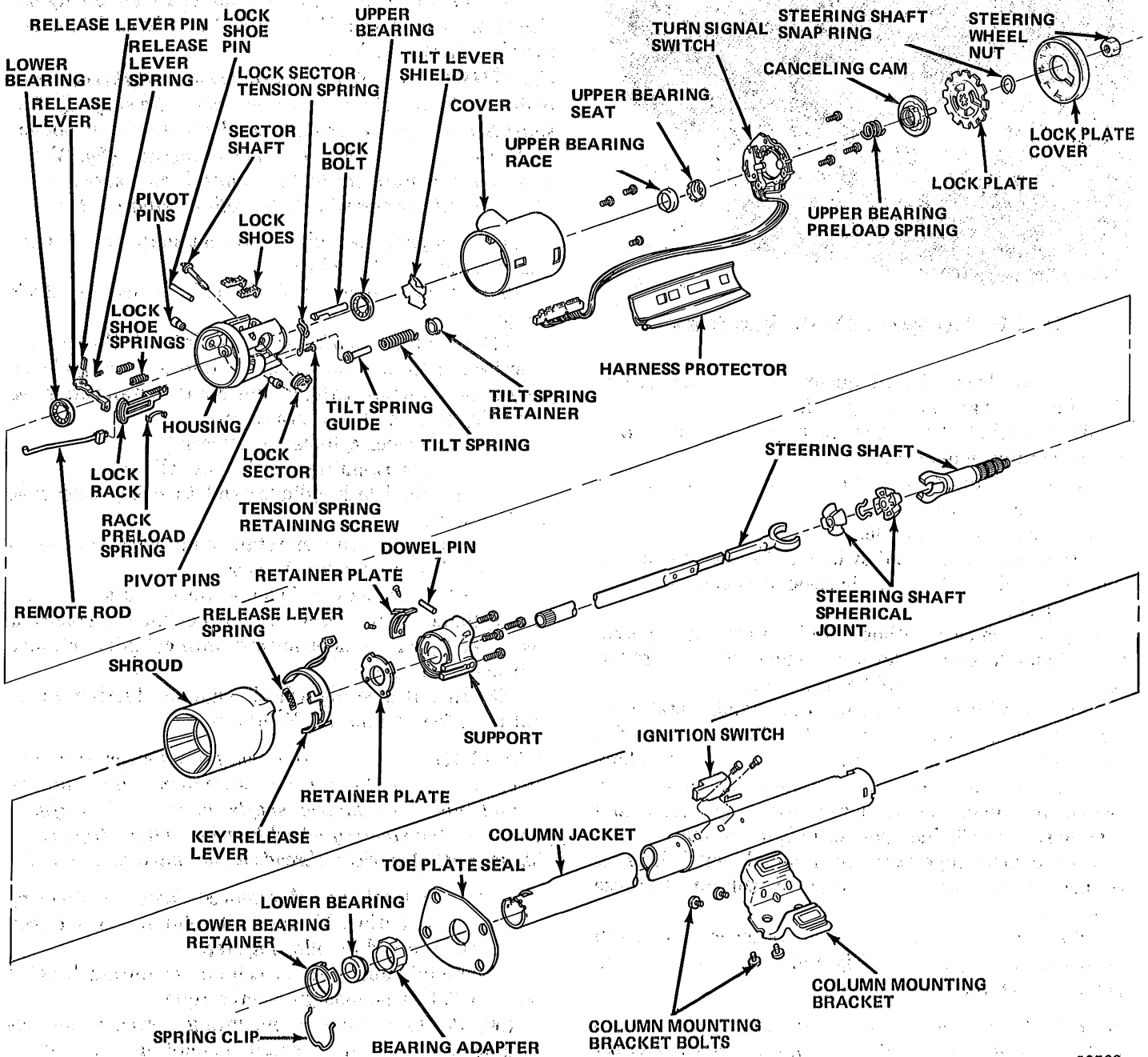

Fig. 2J-47 Tilt Steering Column—CJ and Scrambler Models

(6) Remove lock plate cover. Use two screwdrivers to pry cover off plate and out of column.

(7) Remove tilt and turn signal levers.

(8) Remove hazard warning knob. Press knob inward and turn in counterclockwise direction to remove.

(9) Compress lock plate and unseat steering shaft snap ring as follows:

(a) Inspect and identify steering shaft nut thread type. Metric shafts have identifying groove in steering wheel locating splines (fig. 2J-2). American thread shafts do not have this groove.

(b) If shaft has American threads, use tool J-23653, as is, to compress lock plate and unseat steering shaft snap ring (fig. 2J-6).

(c) If shaft has metric threads, replace compressor tool standard forcing screw with Metric Forcing Screw J-23653-4 before using compressor tool.

WARNING: The lock plate is under strong spring pressure. Do not attempt to remove the snap ring without using the compressor tool.

(10) Remove compressor tool and snap ring. Discard snap ring.

(11) Remove lock plate, canceling cam, and upper bearing preload spring (fig. 2J-47).

(12) Disconnect turn signal switch harness at lower right side of column jacket.

(13) Loosen all toeplate screws.

(14) Remove bolts attaching column mounting bracket to column jacket.

(15) Remove nuts attaching column mounting bracket to instrument panel bolts and remove mounting bracket.

(16) Remove wire harness protector from column jacket (fig. 2J-48).

(17) Wrap tape around harness connector to prevent snagging connector when removed (fig 2J-49).

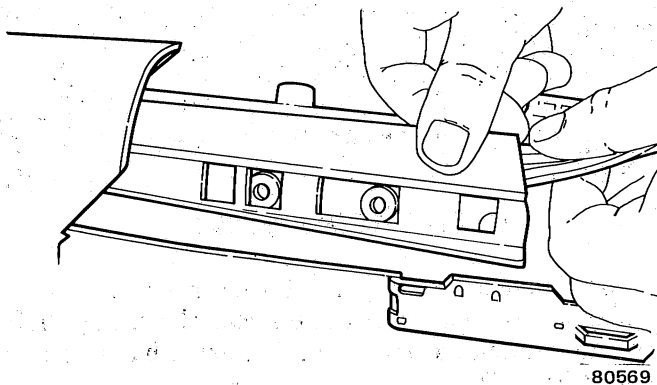

Fig. 2J-48 Harness Protector Removal

(18) Remove turn signal switch attaching screws and remove switch and harness. Pull switch straight up and out of column.

(19) Insert ignition key in ignition lock cylinder and turn cylinder to On position.

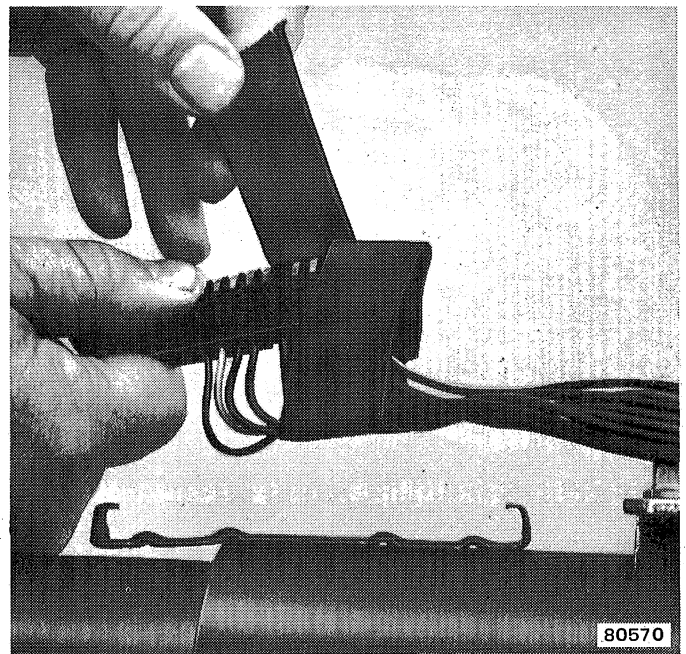

Fig. 2J-49 Taping Harness Connector

(20) Compress ignition lock cylinder retaining tab using thin bladed screwdriver and remove cylinder from column.

NOTE: The retaining tab is accessible through the slot adjacent to the turn signal switch mounting boss (fig. 2J-9). If the tab is not visible through the slot, scrape or knock any casting flash out of the slot to provide access.

(21) Remove cover retaining screws and remove cover from column (fig. 2J-50).

(22) Remove upper bearing race and bearing seat from steering shaft (fig. 2J-51).

(23) Reinstall tilt lever and place column in full upward tilt position.

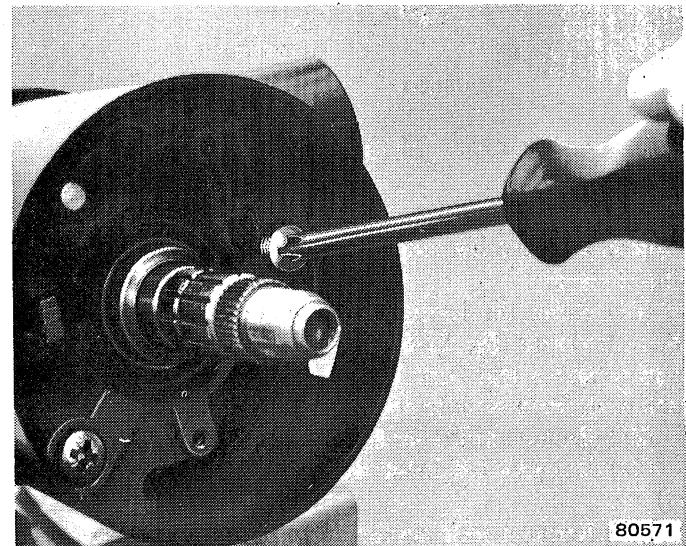

Fig. 2J-50 Cover Removal

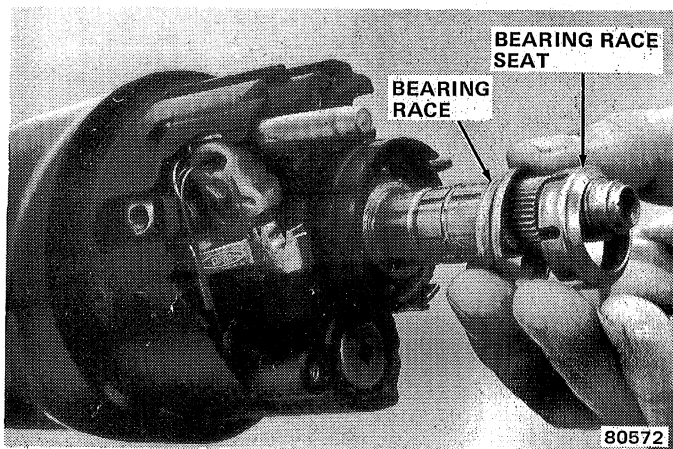

Fig. 2J-51 Upper Bearing Race and Seat Removal/Installation

(24) Remove tilt spring, guide, and retainer using screwdriver (fig. 2J-52). Press retainer inward and turn it counterclockwise until retainer tabs align with housing lugs. Be sure screwdriver blade just fits into retainer slot.

WARNING: *The tilt spring guide is under strong spring pressure.*

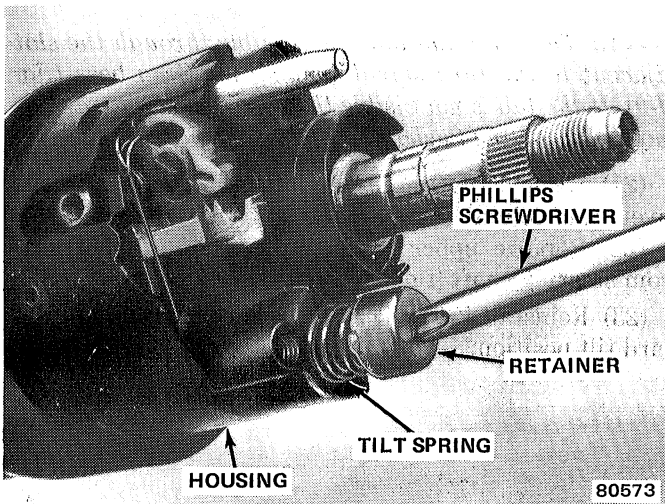

Fig. 2J-52 Tilt Spring and Guide Removal

(25) Place housing in center (nontilt) position.

(26) Remove housing pivot pins using tool J-21854-1 (fig. 2J-36).

(27) Raise tilt lever to disengage lock shoes and remove housing (fig. 2J-53). Pull housing upward to disengage shoes and turn housing to one side to separate lock rack from remote rod.

(28) Remove tilt lever from housing.

(29) Remove tilt lever shield from housing (fig. 2J-54).

(30) Remove lock sector spring retaining screw and remove spring (fig. 2J-55). Rotate spring in clockwise direction to remove it from bolt.

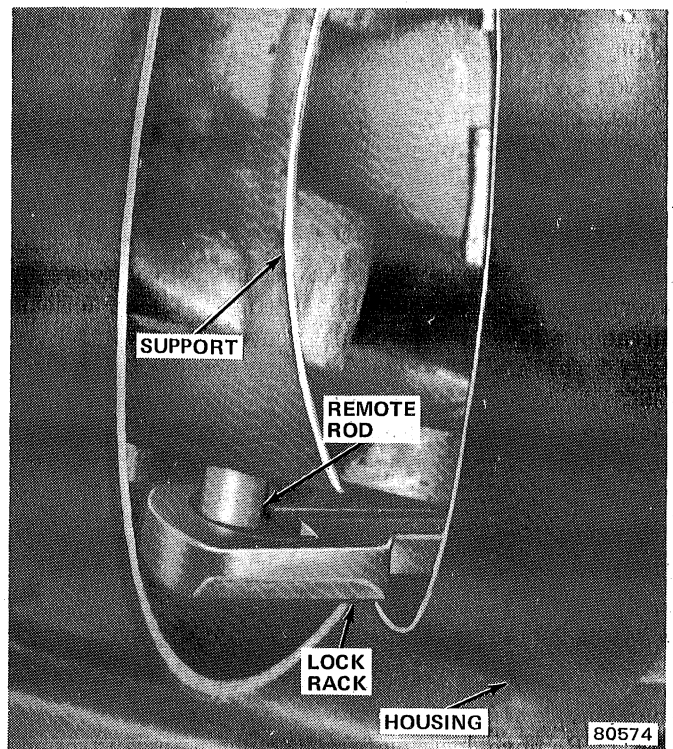

Fig. 2J-53 Housing Removal

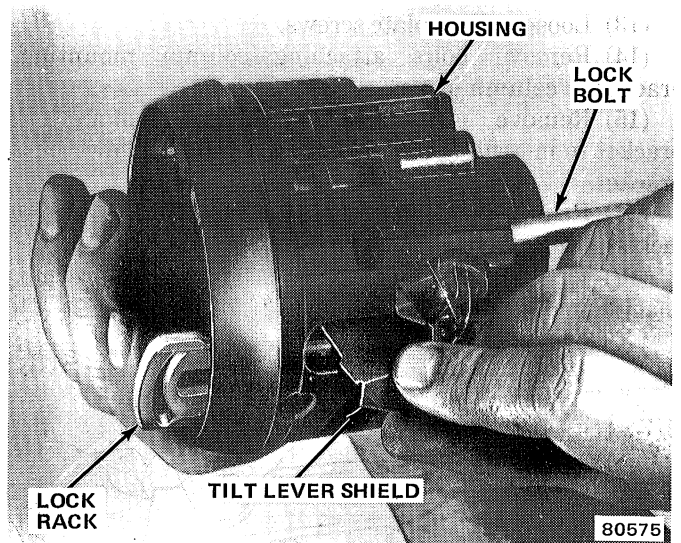

Fig. 2J-54 Tilt Lever Shield Removal

(31) Remove lock sector retaining ring (fig. 2J-55).

(32) Remove lock sector and sector shaft. Tap shaft through sector and out of housing using hammer and punch (fig. 2J-56).

(33) Remove lock bolt, lock rack, rack preload spring, spring shim, if equipped, and remote rod from housing.

(34) Insert wedge between lock shoes and housing to relieve spring tension on tilt and lock shoe pins (fig. 2J-57).

(35) Remove tilt lever pin from housing using tool J-22635 or pin punch (fig. 2J-37).

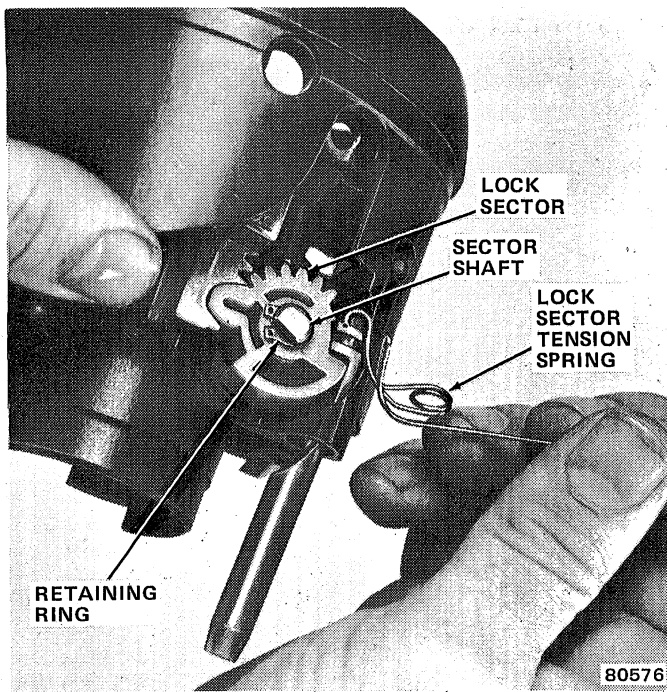

Fig. 2J-55 Lock Sector Tension Spring Removal/Installation

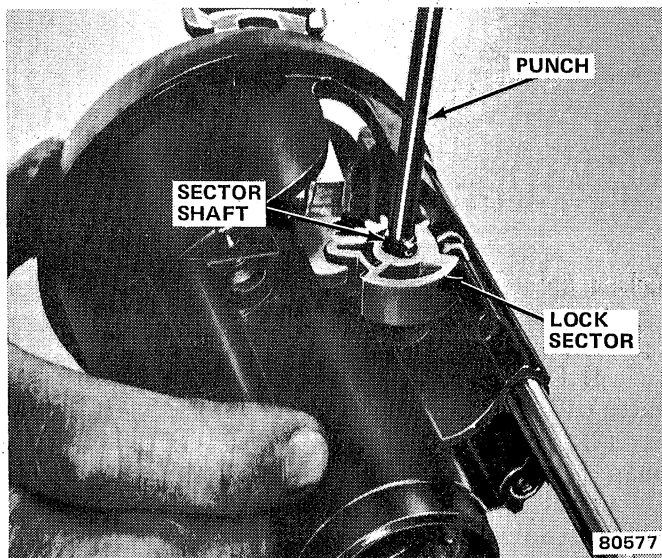

Fig. 2J-56 Lock Sector and Sector Shaft Removal

(36) Remove lock shoe pin from housing using tool J-22635 or pin punch (fig. 2J-38) and remove lock shoes, springs, and wedge.

(37) Remove housing upper and lower bearings and races only if damaged or worn. If bearings and races must be replaced, remove bearings and races using hammer and punch.

NOTE: Discard the housing bearings and races if removed. They are not reusable.

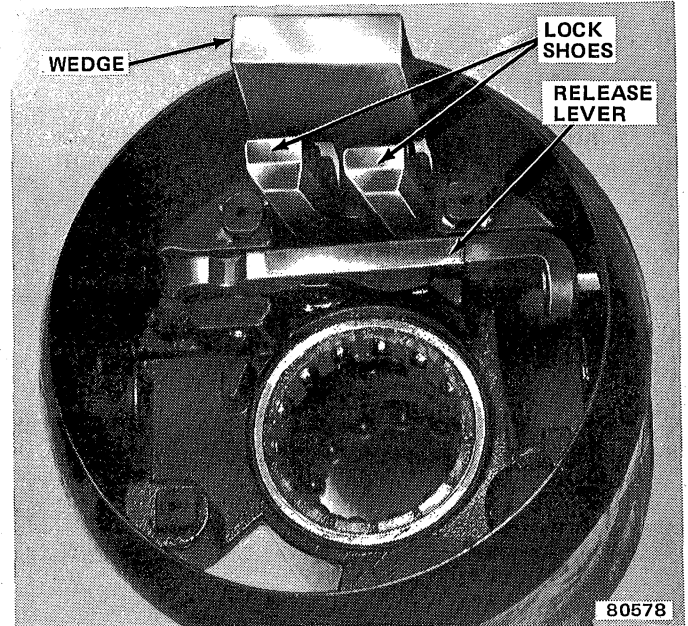

Fig. 2J-57 Relieving Lock Shoe Spring Tension

(38) Disconnect steering shaft at intermediate shaft coupling.

(39) Remove steering shaft through upper end of column (fig. 2J-58).

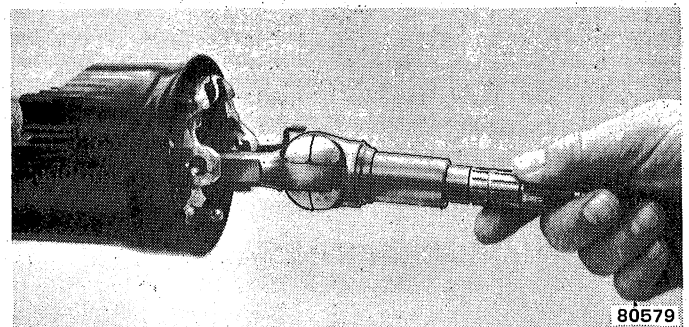

Fig. 2J-58 Steering Shaft Removal/Installation

(40) Remove support attaching bolts and remove support (fig 2J-59). Use 1/4-inch, 12-point deep socket to remove bolts.

(41) Remove retainer plate (fig. 2J-60). Tip upper end of plate rearward and turn plate counterclockwise to remove.

(42) Remove shroud using twisting-pulling motion (fig. 2J-61).

(43) Remove key-release lever and lever spring from shroud (fig. 2J-62). Tip lever forward and lift upward to remove.

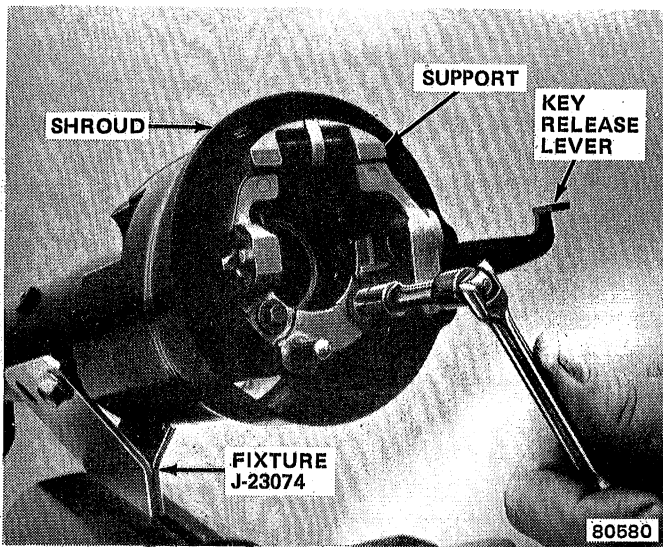

Fig. 2J-59 Support Removal/Installation

- (44) Disconnect ignition switch wire harness connector and remove switch from column.
- (45) Remove snap ring, retainer, and bearing assembly from lower end of column.

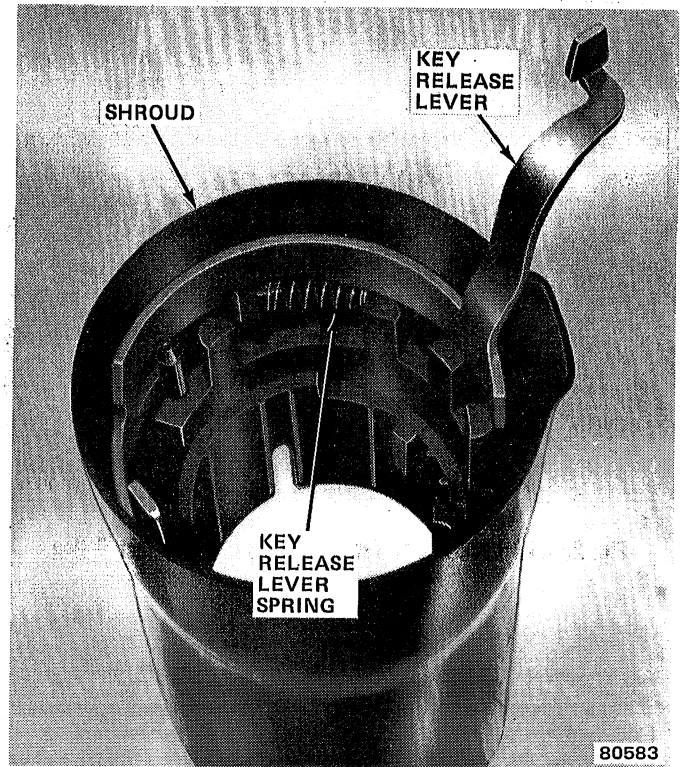

Fig. 2J-62 Key-Release Lever and Spring Removal/Installation

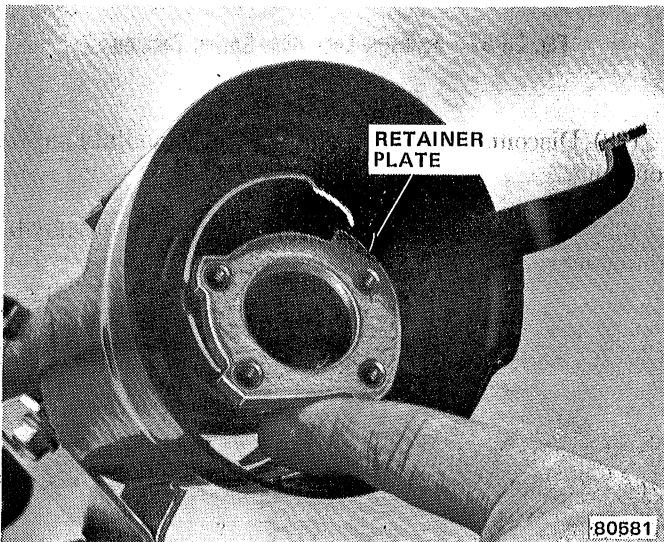

Fig. 2J-60 Retainer Plate Removal/Installation

Column Assembly

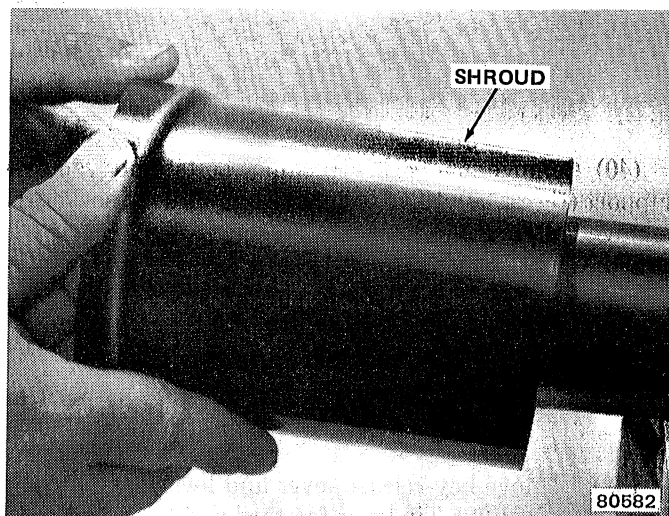

Fig. 2J-61 Shroud Removal/Installation

- (1) Lubricate all bearing, friction, and thrust surfaces with chassis grease.
- (2) Install bearing assembly, bearing retainer, and snap ring in lower end of column (fig. 2J-47).
- (3) Install key-release lever spring on lever and install assembled lever and spring in shroud (fig. 2J-62).
- (4) Align and install shroud on column jacket (fig. 2J-61).
- (5) Install retainer plate (fig. 2J-60). Tip plate toward 12 o'clock position, slide it under jacket opening, and seat it in column jacket notches.
- (6) Align column jacket "V" notch with corresponding "V" on support and install support in column (fig. 2J-63). Press key-release lever downward while pressing support into place to seat support fully.
- (7) Install all support attaching screws finger-tight. Then tighten screws alternately and evenly to 60 inch-pounds (81 N•m) torque (fig. 2J-59).
- (8) Install remote rod in support. Guide rod through upper end of shroud and insert it into rod slot in support.

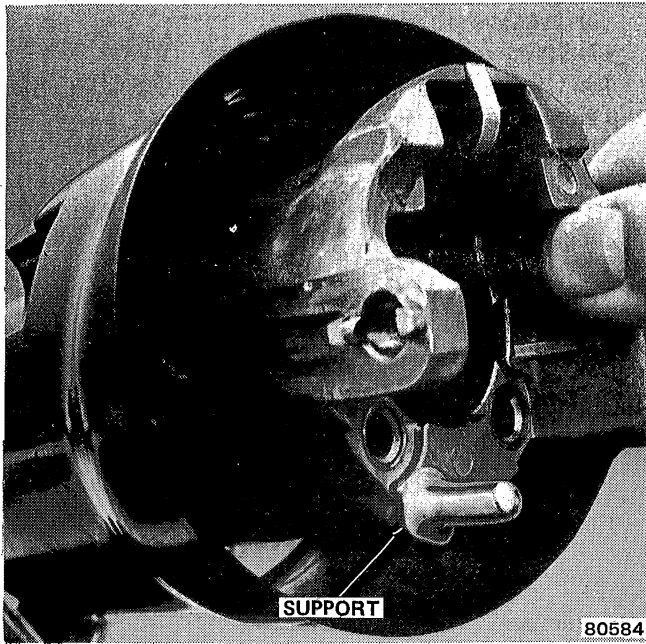

Fig. 2J-63 Support Installation

- (9) Install steering shaft in column (fig. 2J-58).
- (10) Install replacement bearings in housing, if removed. Be sure to lubricate bearings with chassis grease before installation.
- (11) Install lock shoes, lock shoe springs, and lock shoe pin in housing. Use 0.180-inch (4.5 mm) diameter rod to align lock shoes and pin during installation.
- (12) Install release lever, lever spring, and lever pin in housing. Insert wedges between housing and lever to relieve spring tension and ease pin installation (fig. 2J-57).
- (13) Install sector shaft in housing. Lightly tap shaft into housing using punch.
- (14) Install lock sector on shaft. Lightly tap sector onto shaft until shaft snap ring groove is exposed and install sector retaining snap ring.
- (15) Install lock bolt in housing and engage bolt in lock sector cam surface (fig. 2L-56).
- (16) Install lock rack, rack preload spring, and replacement shim (if used) in housing. Square block tooth of rack must engage square block tooth of sector (fig. 2J-56).
- (17) Install lock spring and spring retaining screw (fig. 2J-55). Tighten screw to 35-inch pounds (4 N•m) torque.
- (18) Align and install assembled housing on support (fig. 2J-53). Hold lock shoes in disengaged position to ease housing installation.
- (19) Align pivot pin holes in housing and support and install pivot pins. Press housing downward when first installing pins to prevent damaging pin holes in support. When pins are started in both housing and support, seat pins fully using hammer and punch.

(20) Insert tilt lever in housing and place housing in full upward tilt position.

(21) Lubricate tilt guide and spring liberally with chassis grease and install tilt spring on guide.

(22) Insert assembled tilt spring and guide in housing and install guide retainer on spring (fig. 2J-52). Engage retainer lock tabs with housing lugs by pressing retainer downward and turning clockwise using screwdriver.

(23) Install tilt lever shield in housing.

(24) Remove tilt lever.

(25) Install cover on housing. Align and install cover attaching screws. Tighten screws to 60 inch-pounds (7 N•m) torque.

(26) Install turn signal switch. Guide switch harness and connector through column and position switch in housing. Do not install switch screws at this time.

(27) Insert hazard warning knob in signal switch, press knob inward, and align and install signal switch attaching screws. Tighten screws to 35 inch-pounds (4 N•m) torque. Be sure signal switch is properly seated before tightening screws.

(28) Thread hazard warning knob into signal switch and pull knob outward.

(29) Install upper bearing race and seat in housing (fig. 2J-51).

(30) Install upper bearing preload spring, canceling cam, and lock plate (fig. 2J-47).

(31) Install replacement steering shaft snap ring on sleeve of Compressor Tool J-23653 and install tool on steering shaft (fig. 2J-25).

CAUTION: Identify the steering shaft nut thread type before installing the compressor tool. If the shaft has American threads, use the compressor tool as is. However, if the shaft has metric threads (fig. 2J-2), replace the compressor tool standard forcing screw with Metric Forcing Screw J-23653-4 before installing the tool.

(32) Compress lock plate and seat snap ring in steering shaft groove (fig. 2J-25).

(33) Remove compressor tool. Be sure snap ring is completely seated before removing tool.

(34) Install tilt and turn signal levers. Tighten turn signal lever attaching screw to 15 inch-pounds (2 N•m) torque.

(35) Install shift lever and lever retaining pin, if equipped.

(36) Install ignition lock cylinder. Hold cylinder sleeve, turn knob clockwise against stop, align cylinder tab with housing keyway and insert cylinder in housing. Turn cylinder knob counterclockwise until cylinder mates with lock sector and push cylinder inward until retainer snaps into place.

(37) Insert key in lock cylinder and turn cylinder to Off-Unlock position.

(38) Install ignition switch as follows:

(a) Move switch slider to Accessory position then back two clicks to Off-Unlock position. Remote rod hole in slider should be almost at center (fig. 2J-64).

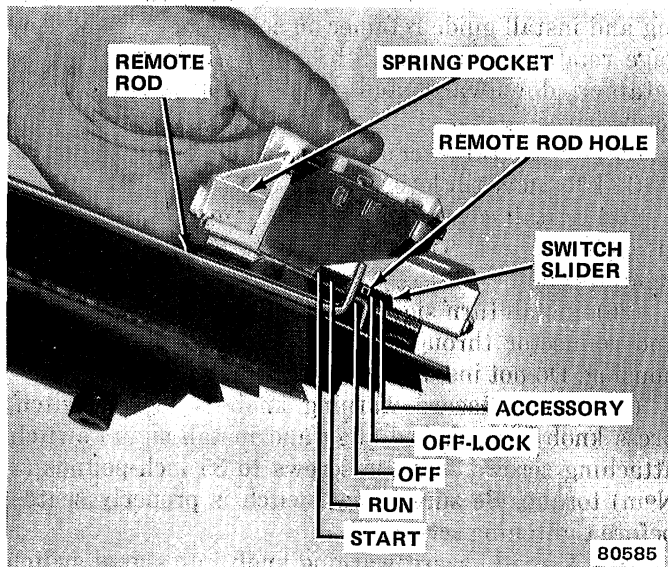

Fig. 2J-64 Ignition Switch Installation

(b) Insert remote rod into slider hole and install switch on column jacket.

(c) Move switch downward to eliminate switch-to-remote rod lash and tighten switch attaching screws to 35 inch-pounds (4 N•m) torque.

(39) Position switch harness protectors, if equipped, over harness and snap protectors into place on column.

(40) Install lock plate cover.

(41) Install steering wheel. Tighten steering wheel nut to 30 foot-pounds (41 N•m) torque.

CAUTION: Some steering shafts have metric size steering wheel nut threads. Identify the shaft nut thread type before installing a replacement nut. Metric shafts have an identifying groove in the steering wheel locating splines (fig. 2J-2). American thread shafts do not have this groove.

(42) Remove column support fixture and install column mounting bracket. Tighten bracket attaching bolts to 20 foot-pounds (27 N•m) torque.

(43) Install column, if removed. Refer to Steering Column Installation.

Removal

- (1) Disconnect battery negative cable.
- (2) Cover painted areas of column.
- (3) Remove column-to-instrument panel bezel.
- (4) Loosen toeplate screws.
- (5) On vehicles with tilt column, place column in neutral (nontilt) position.

(6) Remove steering wheel.

(7) Remove lock plate cover.

(8) Compress lock plate and unseat steering shaft snap ring as follows:

(a) Inspect and identify steering shaft nut thread type. Metric shafts have identifying groove in steering wheel locating splines (fig. 2J-2). American thread shafts do not have this groove.

(b) If shaft has American threads, use Compressor Tool J-23653 as is to compress lock plate and unseat snap ring.

(c) If shaft has metric threads, replace compressor tool standard forcing screw with Metric Forcing Screw J-23653-4 before installing tool on shaft.

(9) Remove compressor tool and snap ring. Discard snap ring.

(10) Remove lock plate, canceling cam, and upper bearing preload spring.

(11) Place turn signal lever in right turn position and remove lever.

(12) Remove hazard warning knob. Press knob inward and turn counterclockwise to remove.

(13) Remove column wiring harness protectors, if equipped.

(14) Disconnect column wiring harness connectors at base of column.

(15) If Cruise Command switch is to be serviced, remove switch and harness by removing turn signal lever attaching screw and removing lever, switch, and switch harness as assembly.

(16) If turn signal switch is to be serviced, remove hazard warning knob and turn signal lever. Remove switch attaching screws and remove switch from column.

Installation

(1) If turn signal switch was serviced, install switch in housing and install attaching screws. Tighten screws to 35 inch-pounds (4 N•m) torque. Install hazard warning knob and install turn signal lever. Tighten lever attaching screw to 15 inch-pounds (2 N•m) torque.

(2) If Cruise Command switch was serviced, install signal lever and switch assembly and install attaching screws. Tighten screws to 35 inch-pounds (4 N•m) torque.

(3) Install upper bearing preload spring, canceling cam, and lock plate on steering shaft.

(4) Install replacement steering shaft snap ring on sleeve of Compressor Tool J-23653 and install tool on steering shaft.

CAUTION: Identify the steering shaft nut thread type before installing the compressor tool. If shaft has American threads, use tool J-23653 as is. However, if the shaft has metric threads (fig. 2J-2), replace the compressor tool standard forcing screw with Metric Forcing Screw J-23653-4 before using the tool.

(5) Compress lock plate and seat steering shaft snap ring in shaft groove. Remove compressor tool after snap ring installation.

(6) Install lock plate cover.

(7) Install steering wheel and install replacement steering wheel nut. Tighten nut to 30 foot-pounds (41 N•m) torque.

CAUTION: *Some steering shafts have metric size steering wheel nut threads. Be sure to install the proper thread-type nut. Metric shafts have an identifying groove in the steering wheel locating splines (fig. 2J-2).*

(8) Connect signal switch or Cruise Command switch harness connectors at base of column and install harness protector.

(9) Install and tighten column-to-mounting bracket bolts to 20 foot-pounds (27 N•m) torque.

(10) Install and tighten column mounting bracket-to-instrument panel bolts to 20 foot-pounds (27 N•m) torque.

(11) Install column bezel.

(12) Tighten toeplate bolts to 10 foot-pounds (14 N•m) torque.

(13) Remove protective covering from painted areas of column.

(14) Connect battery negative cable.

IGNITION SWITCH

Removal

(1) Insert key in lock cylinder and turn cylinder to Off-Unlock position.

(2) Disconnect battery negative cable.

(3) Disconnect harness connectors at switch.

(4) Remove switch attaching screws.

(5) Disengage remote rod from switch slider and remove switch from column.

Installation

(1) Move switch slider to Accessory position (fig. 2J-64).

(2) Move switch slider back two clicks to Off-Unlock position (fig. 2J-64).

(3) Engage remote rod in switch slider and position switch on column. Do not move slider when positioning switch on column jacket.

(4) Install and tighten switch attaching screws to 35 inch-pounds (4 N•m) torque.

(5) Connect harness connectors to switch.

(6) Connect battery negative cable.

IGNITION LOCK CYLINDER

The key-operated lock cylinder is located at the upper end of the steering column and is mounted in the column housing or cover. The lock cylinder is a two-piece assembly and can be removed, disassembled, and repaired or recoded if necessary.

Conditions Requiring Service

Key Lost—Key Code Number Known

The key code may be converted to a five-digit number that determines key bitting. This number may be obtained from the catalogues furnished by manufacturers of key cutting machines or by calling the Jeep zone office.

Defective Ignition Lock—Ignition Key Available—No Key Code Number

New lock cylinders are available from service parts warehouses only as uncoded cylinders without tumblers. Tumblers are ordered under five different part numbers, one for each depth of cut available. Refer to Key Coding.

Key Lost—Key Code Lost Or Not Known

Contact the servicing dealer and provide the dealer with the vehicle identification number. The dealer may have a record of the key codes involved. If not, the key code numbers assigned to the vehicle may be obtained from the Jeep zone office.

Lock Cylinder Removal

(1) Disconnect battery negative cable.

(2) Apply protective material to painted areas of column.

(3) Remove steering wheel.

(4) Remove lock plate cover. Use two screwdrivers to pry cover out of column.

(5) Compress lock plate and unseat steering shaft snap ring as follows:

(a) Inspect and identify steering shaft nut thread type. Metric shafts have identifying groove in steering wheel locating splines (fig. 2J-2). American thread shafts do not have this groove.

(b) If shaft has American threads, use Compressor Tool J-23653, as is, to compress lock plate and unseat snap ring (fig. 2J-6).

(c) If shaft has metric threads, replace compressor tool standard forcing screw with Metric Forcing Screw J-23653-4 before installing tool on steering shaft.

WARNING: *The lock plate is under strong spring pressure. Do not attempt to remove the steering shaft snap ring without using the compressor tool.*

(6) Remove compressor tool and snap ring. Discard snap ring.

(7) Remove lock plate, canceling cam, and upper bearing preload spring.

(8) Remove turn signal lever attaching screw and remove lever.

(9) Press hazard warning knob inward and turn knob counterclockwise to remove it.

(10) Disconnect turn signal and Cruise Command wire harness connectors at base of column.

(11) Remove turn signal switch attaching screws and move switch aside to provide working clearance. It is not necessary to remove switch and harness completely.

(12) Insert key in lock cylinder. On manual transmission columns, place cylinder in On position. On automatic transmission columns, place cylinder in Off-Lock position.

(13) Compress lock cylinder retaining tab using thin blade screwdriver and remove lock cylinder from column.

NOTE: The lock cylinder retaining tab is accessible through the slot adjacent to the turn signal switch mounting boss (fig. 2J-9). If the tab is not visible through the slot, scrape or knock any casting flash out of the slot to provide access.

Lock Cylinder Installation

(1) Install lock cylinder as follows:

(a) Insert key in lock cylinder.

(b) Hold cylinder sleeve and turn key clockwise until key stops.

(c) Align lock cylinder retaining tab with keyway in housing and insert cylinder into column.

(d) Push cylinder inward until it contacts lock sector. Rotate cylinder to engage it with lock sector, and push cylinder inward until cylinder retaining tab engages in housing groove.

(2) Align and install turn signal switch in column.

(3) Install and tighten switch attaching screws to 35 inch-pounds (4 N•m) torque.

(4) Install hazard warning knob. Tighten knob to 5 inch-pounds (0.56 N•m) torque.

(5) Install turn signal lever. Tighten lever attaching screw to 15 inch-pounds (2 N•m) torque.

(6) Install upper bearing preload spring, canceling cam, and lock plate on steering shaft.

(7) Install replacement steering shaft snap ring on sleeve of Compressor Tool J-23653 and install tool on steering shaft (fig. 2J-6).

CAUTION: Identify the steering shaft nut thread type before installing the compressor tool. If the shaft has American threads, use the tool as is. However, if the shaft has metric threads (fig. 2J-2), replace the compressor tool standard forcing screw with Metric Forcing Screw J-23653-4 before installing the tool on the shaft.

(8) Compress lock plate with compressor tool and seat snap ring in steering shaft groove (fig. 2J-6).

(9) Remove compressor tool.

(10) Install lock plate cover.

(11) Install steering wheel and tighten steering wheel nut to 30 foot-pounds (41 N•m) torque.

CAUTION: Some steering shafts have metric steering wheel nut threads. Identify the shaft nut thread type before installing a replacement nut. Metric shafts have an identifying groove in the steering wheel locating splines (fig. 2J-2).

(12) Connect column wiring harness connectors at base of column.

(13) Remove protective covering from column painted areas.

(14) Connect battery negative cable.

(15) Reset clock, if equipped.

Lock Cylinder Disassembly

In the following procedures, all references to turning the key clockwise or counterclockwise are made as if the cylinder is being viewed from the key-end.

(1) Insert key in lock cylinder.

(2) Hold lock sleeve and turn cylinder to Lock position.

(3) Fabricate plunger pin compressor tool from paper clip. Make 90° bend in one end of clip about 1/4 inch (6.35 mm) from end (fig. 2J-65).

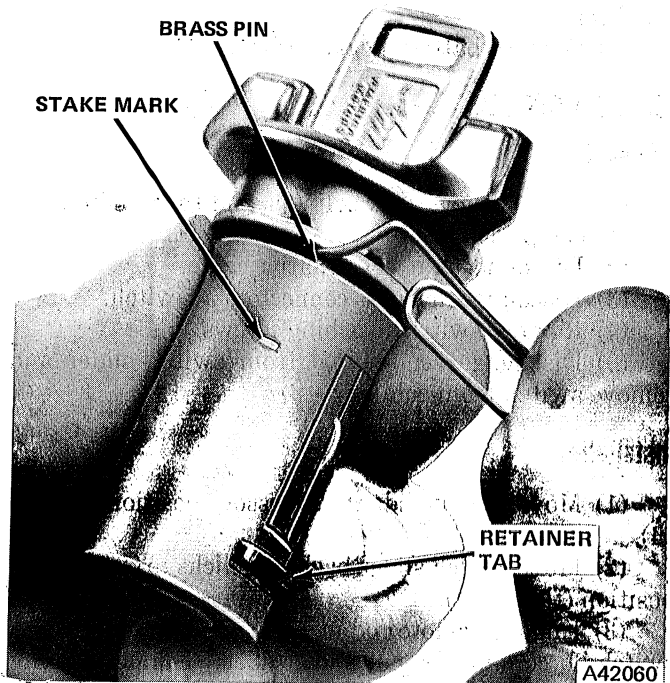
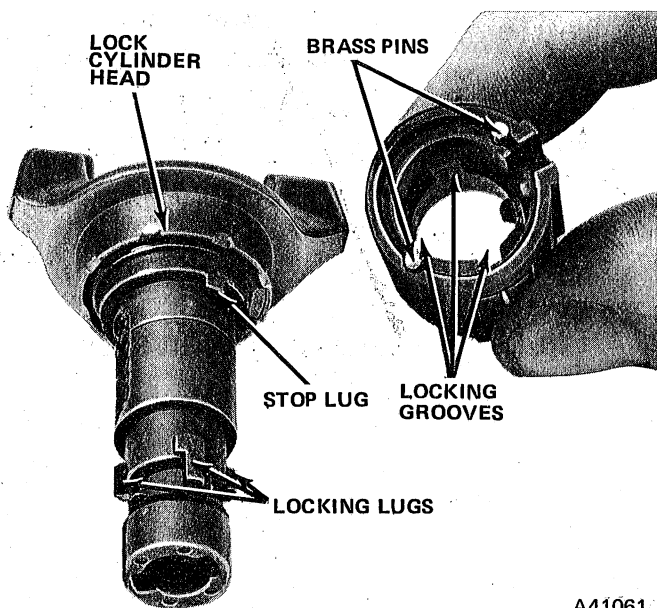

Fig. 2J-65 Compressing Lock Cylinder Plunger Pin

(4) Turn lock cylinder to Accessory position. Brass plunger pins in lock sleeve should now bear against lock cylinder stop lug (fig. 2J-66).

(5) Compress plunger pin using paper clip compressor tool (fig. 2J-65).

NOTE: There are two brass pins and two staking marks on the lock sleeve. The brass pin that must be compressed in order to separate the cylinder and sleeve is located just above the stake mark that is positioned above and to the left of the retaining tab (fig. 2J-65).



A41061

Fig. 2J-66 Lock Cylinder and Sleeve Disassembled

- (6) Hold brass plunger pin in compressed position and turn lock cylinder clockwise using paper clip.
- (7) Stop turning cylinder when it springs upward slightly. Cylinder locking lugs are now aligned with sleeve locking grooves.
- (8) Remove ignition key.
- (9) Turn sleeve and cylinder upside down.
- (10) Fabricate wire hook from additional paper clip.
- (11) Lift nylon stop on lock sleeve using wire hook and separate cylinder from sleeve (fig. 2J-67).

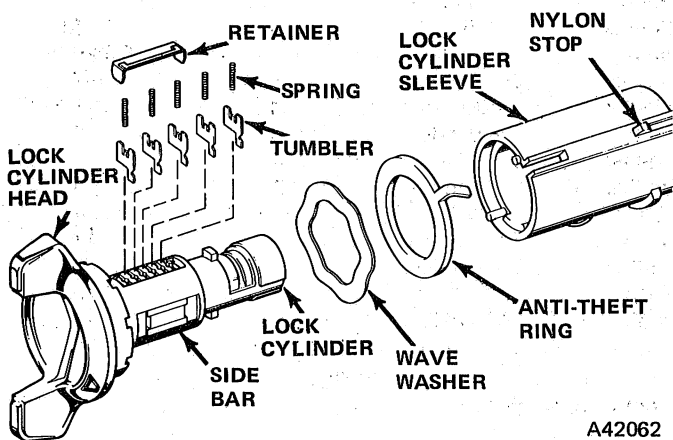

A42062

Fig. 2J-67 Ignition Lock Cylinder Assembly

NOTE: If the cylinder does not separate from the sleeve easily, tap the assembly lightly on the workbench to free the sleeve from the cylinder.

- (12) Pry tumbler retainer from cylinder and remove tumbler springs (fig. 2J-67).
- (13) Pull side bar outward slightly and remove tumblers from cylinder (fig. 2J-67).

Key Coding

To determine the tumblers needed when the key code is not available, use the code diagram as follows (fig. 2J-68):

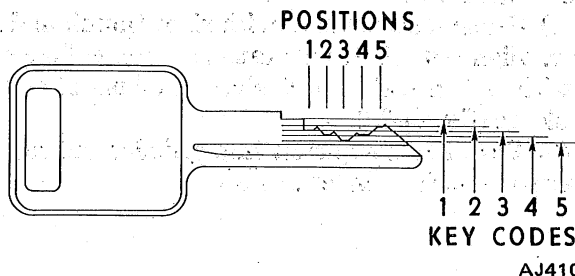

AJ41049

Fig. 2J-68 Key Coding Diagram

- (1) Place key over coding diagram with uncut side of key aligned exactly with diagram. Each of five positions will align with key notches.
- (2) Starting at head of key blade, determine and record lowest level tumbler number that is visible in each position (1 through 5).
- (3) After tumbler number sequence is determined, lock cylinder is ready for assembly.
- (4) Starting at key end of lock cylinder, insert tumblers in proper slots and in order required by key code. Pull side bar outward slightly to allow tumblers to drop completely into place.
- (5) Install a spring on each tumbler.
- (6) Insert tumbler retainer so two end prongs slide into slots in cylinder.
- (7) Press retainer downward until it is seated.
- (8) Insert key in lock cylinder and check tumbler operation. If tumblers are properly installed, side bar will drop downward when key is inserted. If side bar does not move, disassemble cylinder and check for incorrect assembly or coding of key and tumblers.
- (9) If cylinder is correctly assembled and operates properly, stake each end of spring retainer in place using punch (fig. 2J-69).

Assembly

- (1) Insert key completely into lock cylinder, then pull key out two notches.

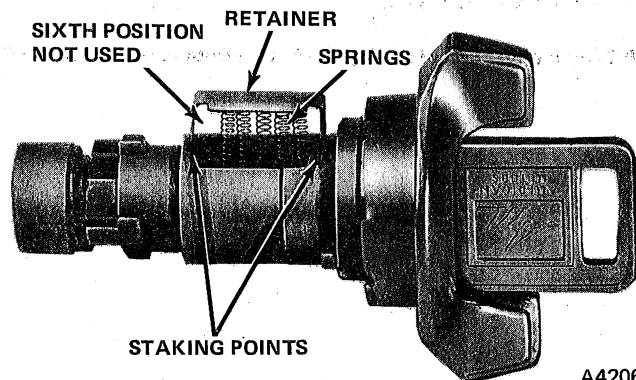

A42063

Fig. 2J-69 Tumbler and Spring Installation

(2) Install wave washer and anti-theft ring on lock cylinder (fig. 2J-70).

(3) Grasp lock sleeve with left thumb and forefinger and hold nylon stop in lock sleeve upward with forefinger (fig. 2J-70).

(4) Grasp lock cylinder with right thumb and forefinger, align anti-theft ring tang and lock cylinder side bar with slot in wall of lock sleeve, and insert cylinder into sleeve (fig. 2J-70).

(5) Push key completely into cylinder and turn key clockwise to lock cylinder in sleeve.

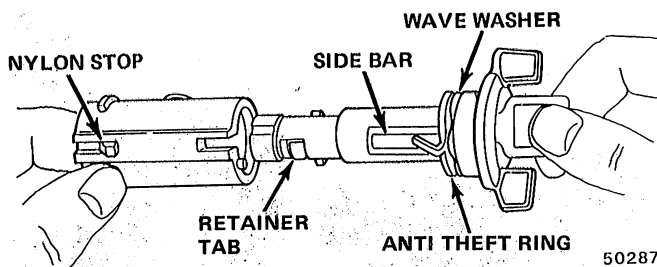

Fig. 2J-70 Assembling Lock Cylinder and Sleeve

SPECIFICATIONS

Torque Specifications

Service Set-To Torques should be used when assembling components. Service In-Use Recheck Torques should be used for checking a pre-tightened item.

	USA (ft-lbs)		Metric (N·m)	
	Service Set-To Torque	Service In-Use Recheck Torque	Service Set-To Torque	Service In-Use Recheck Torque
Clamp Bolt, Flexible Coupling	30	25-35	41	34-47
Clamp Bolt, Intermediate Shaft	45	40-55	61	54-75
Clamp Bolt, Steering Shaft U-Joint	45	40-55	61	54-75
Column Mounting Bracket Bolt	20	15-25	27	20-34
Column Mounting Bracket-to-Instrument Panel Bolts	20	15-25	27	20-34
Cover Screws (Auto. Col.)	60 in-lbs.	50-65 in-lbs.	7	5-7
Cover Screws (Tilt Col.)	100 in-lbs.	95-105 in-lbs.	11	10-12
Hazard Warning Knob	5 in-lbs.	3-7 in-lbs.	0.56	0.34-0.79
Housing Screws (Std. Col.)	60 in-lbs.	55-65 in-lbs.	7	5-7
Housing Screws (Tilt Col.)	100 in-lbs.	95-105 in-lbs.	11	10-12
Ignition Switch Mounting Screws	35 in-lbs.	30-40 in-lbs.	4	3-5
Lock Sector Tension Spring Screw	35 in-lbs.	30-40 in-lbs.	4	3-5
Shroud Screws (Man. Trans. Col.)	18 in-lbs.	14-22 in-lbs.	2	2-3
Steering Wheel Nut	30	25-35	41	34-47
Support Screws (Tilt Col.)	60 in-lbs.	50-65 in-lbs.	7	5-7
Tilt Lever Screw	35 in-lbs.	30-40 in-lbs.	4	3-5
Toe Plate Screws	10	10-18	14	14-24
Turn Signal Lever Screw	15 in-lbs.	12-20 in-lbs.	2	1-3
Turn Signal Switch Screws	35 in-lbs.	28-40 in-lbs.	4	3-5

All Torque values given in foot-pounds and newton-meters with dry fits unless otherwise specified.

Tools

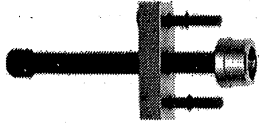

**J-23072
SHIFT TUBE REMOVER**



**J-22635
PIN REMOVER AND
INSTALLER**



**J-23653
LOCK PLATE
COMPRESSOR**

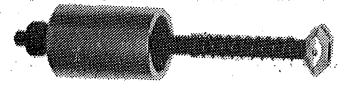

**J-23073
SHIFT TUBE
INSTALLER**

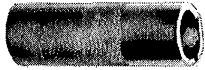

**J-22569
STEERING SHAFT SNAP RING
REMOVER AND INSTALLER**



**J-21232
STEERING WHEEL
PULLER**

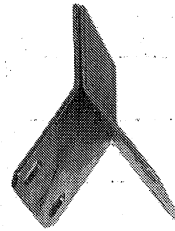

**J-23074
STEERING COLUMN
HOLDING FIXTURE**



**J-21854-1 PIVOT
PIN PULLER**

