

TRANSFER CASE

2D

SECTION INDEX

	Page		Page
General Information	2D-1	Model 300 Transfer Case	2D-37
Model 208 Transfer Case	2D-6	Tools	2D-48
Model 219 Quadra-Trac Transfer Case	2D-22		

GENERAL INFORMATION

	Page		Page
General	2D-1	Transfer Case Removal	2D-5
Towing	2D-1	Transfer Case Service	2D-3
Transfer Case Installation	2D-5	Transfer Case Shift Linkage	2D-3

GENERAL

Three transfer case models are used in Jeep vehicles. They are models 208, 219 and 300. Models 208 and 219 are aluminum case chain drive units and are used in Cherokee, Wagoneer and Truck models exclusively. Model 300 is a cast iron case gearbox type unit and is used in CJ and Scrambler models only. All three models have an integral four-wheel low range.

Model 208 is a four position unit providing four-wheel drive high and low ranges, a two-wheel high range and a neutral position. Model 208 is a part-time four-wheel drive unit. Torque input in four-wheel high and low ranges is undifferentiated. The range positions on the model 208 are selected by a floor mounted gearshift lever. Refer to the model 208 section for shift patterns. Model 208 is the standard equipment transfer case for Cherokee, Wagoneer and Truck models. Front drive hubs are also standard equipment on Jeep models equipped with this transfer case.

The model 219 Quadra-Trac, full time four-wheel drive transfer case is available as an option on Cherokee, Wagoneer and Truck models with automatic transmission only. This transfer case is also a four position unit providing four-wheel high and low ranges, a neutral position for towing and a four-high lock position for use only when the vehicle is immobile due to excessive wheel spin.

The model 219 provides fully differentiated operation in four-wheel high range. This is accomplished through

a torque biasing viscous coupling.

The 219 is a chain drive unit employing two drive sprockets and an interconnecting drive chain. The 219 range positions are selected by a floor mounted gearshift lever. Refer to the model 219 section for shift patterns.

NOTE: *Front drive hubs are not available nor recommended for vehicles equipped with the model 219 Quadra-Trac transfer case.*

Model 300 is a cast iron case, four position gearbox type transfer case. It is used in CJ and Scrambler models only and provides four-wheel high and low ranges, a neutral position and a two-wheel drive high range. Model 300 is a part-time unit. Torque input in four-wheel high and low ranges is undifferentiated.

TOWING

Emergency Towing

If the vehicle is disabled and is to be towed with the front or rear wheels off the ground, towing speed should be limited to 30 mph (48 km/h) for a distance no greater than 15 miles (24 km).

Towing Vehicles with Manual Transmission and Model 208 or 300 Transfer Case

Ignition Key Available: Shift transmission and transfer case into Neutral. Vehicle can now be towed with all

four wheels on the ground or with front or rear wheels raised. Turn front drive hubs to 4 x 4 or Lock position. Turn ignition key to Off position to unlock steering column.

Ignition Key Not Available and Vehicle is Unlocked: Shift transmission and transfer case into Neutral and tow vehicle with front wheels raised.

Ignition Key Not Available and Vehicle is Locked: Place dolly under rear wheels and tow vehicle with front end raised. Or, disconnect rear propeller shaft at rear axle yoke (be sure to mark the shaft and yoke for proper alignment at reassembly), secure shaft to underside of vehicle, and tow with front end raised.

NOTE: *On CJ and Scrambler models, when towing vehicle over 200 miles (300 km), stop towing every 200 miles (300 km). With the transfer case still in N (Neutral) and transmission in gear, start engine and rev engine for about one minute to circulate oil in the transfer case.*

Towing Vehicle with Automatic Transmission and Model 208 or 300 Transfer Case

Ignition Key Available: Turn ignition key to Off position to unlock steering column and gearshift selector linkage. Move gearshift lever to Park and transfer case shift lever to Neutral.

Ignition Key Not Available: Place dolly under rear wheels and tow vehicle with front end raised. Or, disconnect rear propeller shaft at rear axle yoke (index mark yoke for correct assembly), secure shaft to underside of vehicle, and tow with front wheels raised.

NOTE: *On CJ and Scrambler models, when towing vehicle over 200 miles (300 km), stop towing every 200 miles (300 km) and with the transfer case still in N (Neutral), start engine, place automatic transmission in D (Drive), and rev engine for about one minute to circulate oil in the transfer case.*

Towing Vehicle with Automatic Transmission and Model 219 Quadra-Trac Transfer Case

Ignition Key Available: Vehicle can be towed with all four wheels on the ground without disconnecting propeller shafts. Turn ignition key to Off position to unlock steering wheel. Move gearshift lever to Park and shift transfer case shift lever to Neutral position.

Ignition Key Not Available: Place dolly under rear wheels and tow vehicle with front wheels raised. Or, disconnect rear propeller shaft at rear axle (mark yoke for correct assembly), secure shaft to underside of vehicle, and tow with front wheels raised.

Recreational Towing

Jeep vehicles can be towed behind a recreational vehicle such as a motor home, but the following instruc-

tions must be followed to avoid damaging drive line components. Also be sure to check and comply with federal, state and local laws or ordinances regarding this type of towing.

With Manual Transmission and Model 208 or Model 300 Transfer Case

- (1) Turn ignition switch to Off position to unlock steering wheel.
- (2) Shift transmission into gear and the transfer case into Neutral.
- (3) Turn selective drive hubs to 4 x 4 or Lock position, for axle lubrication.

With Automatic Transmission and Model 208 or Model 300 Transfer Case

- (1) Turn ignition switch to Off position to unlock steering wheel.
- (2) Shift automatic transmission into Park.
- (3) Shift transfer case into Neutral position.
- (4) Turn selective drive hubs to 4 x 4 or Lock position for axle lubrication.

With Automatic Transmission and Model 219 Quadra-Trac Transfer Case

- (1) Turn ignition switch to Off position to unlock steering wheel.
- (2) Shift automatic transmission into Park.
- (3) Shift transfer case into Neutral position.

Trailer Towing and Campers

The Jeep Corporation new vehicle warranty includes conditions and limitations for vehicles used in towing trailers or campers or installation of slide-in campers on Jeep Trucks. The requirements and recommendations in this manual and other factory literature must be followed in order to maintain this coverage.

In addition to the vehicle maintenance and servicing requirements set forth in this manual, the GVW and GAW ratings are of special significance. When a Jeep vehicle is to be used for trailer or camper towing, or slide-in camper installations in Jeep Trucks, it is extremely important that the GVW or GAW ratings not be exceeded by the addition of:

- The tongue weight of a trailer.
- The weight transferred to a Truck model by the mounting of a fifth-wheel trailer.
- The weight of a slide-in camper or any other type of truck camper.
- The weight of any other type of vehicle put in or on the towing vehicle.

Remember that additional items placed in or on the trailer or mounted camper will add to the load.

CAUTION: Jeep Corporation will not be responsible for brake performance if the Jeep vehicle and trailer hydraulic brake systems are interconnected in any way. A separate brake system is recommended, and actually required in some states, for all trailers weighing 1,000 pounds (454 kg) or more.

TRANSFER CASE SERVICE

All three transfer case models are fully serviceable units and can be disassembled for cleaning, inspection, overhaul and adjustment procedures. In-vehicle and out-of-vehicle servicing procedures are outlined in this chapter. Refer to the necessary subsection for service diagnosis, principles of operation and all servicing, lubrication, and adjustment procedures.

TRANSFER CASE SHIFT LINKAGE

Cherokee-Wagoneer-Truck with Manual Transmission

Removal

- (1) Raise vehicle.
- (2) Disconnect shift lever link from operating lever and transfer case shift lever (fig. 2D-1). Do not lose washers, grommets, and bushings that retain link in levers.
- (3) Lower vehicle.
- (4) Remove screws attaching shift lever boot to floorpan and slide boot upward on shift lever.
- (5) Remove screws attaching shift lever support bracket to floorpan (fig. 2D-1).
- (6) Remove knob from transfer case shift lever.
- (7) Slide shift lever out of boot and remove lever and support bracket as assembly.
- (8) Remove shoulder bolt from support bracket and remove shift lever from bracket. Do not lose shift lever bushing or spring washer.
- (9) Inspect lever, link, support bracket, shoulder bolt and bushings. Replace any component that is bent, cracked, broken, scored or excessively worn.

Installation

- (1) Install shift lever bushing in shift lever (fig. 2D-1).
- (2) Install shift lever in support bracket.
- (3) Align lever bushing with holes in support bracket and install spring washer and shoulder bolt. Tighten bolt securely.
- (4) Slide shift lever into boot and into floorpan hole.
- (5) Position lever support bracket on floorpan and install bracket attaching screws.
- (6) Install knob on shift lever.
- (7) Raise vehicle.
- (8) Install grommet in operating lever, if removed.

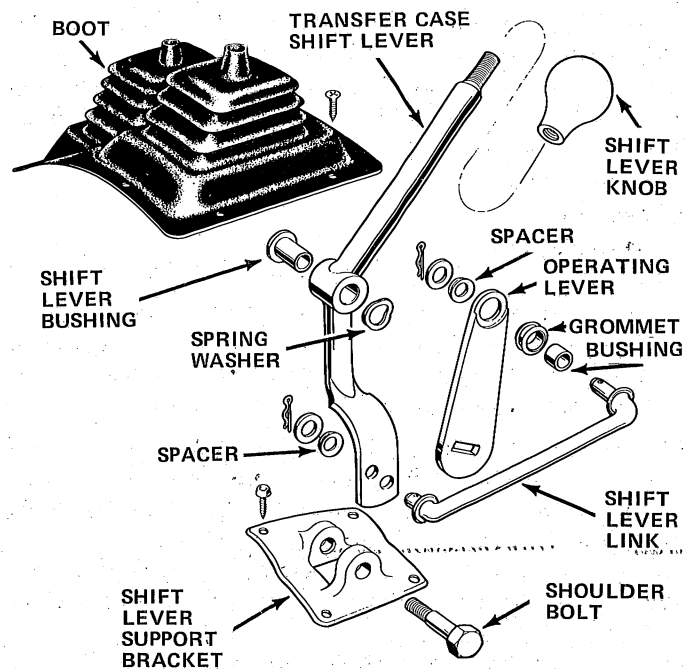

81018

Fig. 2D-1 Transfer Case Shift Linkage—
Cherokee-Wagoneer-Truck with Manual Transmission

- (9) Install bushing on end of shift lever link that attaches to operating lever.
- (10) Connect shift lever link to operating lever and shift lever using spacers and washers removed previously, and new cotter pins.
- (11) Lower vehicle.
- (12) Install screws that attach shift lever boot to floorpan.

Cherokee-Wagoneer-Truck with Automatic Transmission

Removal

- (1) Remove screws attaching pivot bushing retainer assembly to floorpan (fig. 2D-2).
- (2) Raise vehicle.
- (3) Disconnect lower shift rod at operating lever (fig. 2D-2). Retain flat washer, wave washer and push-on retainer that attach rod end to lever.
- (4) Disconnect upper shift rod at shift lever. Retain cotter pin, spacer, and washer that attach rod end to shift lever.
- (5) Disconnect lower shift rod at bellcrank lever. Retain cotter pin, spacer and washer that attach lower shift rod trunnion to bellcrank (fig. 2D-2).
- (6) Disconnect upper shift rod at bellcrank lever. Retain bushing, cotter pin, spacer, and washer that attach rod end to bellcrank.
- (7) Remove bolt, nut and spring washer that attach bellcrank lever (fig. 2D-2). Remove lever and bushing.
- (8) Lower vehicle.
- (9) Remove shift lever, pivot bushing and bushing retainer as assembly.

(10) Separate pivot bushing retainer assembly and remove pivot bushing and lever.

(11) Clean and inspect shift linkage components. Replace any component that exhibits excessive wear, scoring, distortion, or is cracked, bent or broken.

Installation

(1) Assemble pivot bushing, shift lever and bushing retainer assembly.

(2) Install shift lever assembly in floorpan and install screws that attach pivot bushing retainer to floorpan.

(3) Raise vehicle.

(4) Install bushing in bellcrank lever (if removed) and install lever. Tighten lever attaching bolt and nut securely. Be sure spring washer is positioned on bolt before installing bolt.

(5) Connect upper shift rod to bellcrank lever. Be sure grommet is installed in lever and bushing on rod end before attaching rod to lever.

(6) Connect lower shift rod to operating lever.

(7) Connect lower shift rod trunnion to bellcrank lever.

(8) Connect upper shift rod to transfer case shift lever.

(9) Lower vehicle.

(10) Check linkage operation. If adjustment is necessary, adjust linkage at lower shift rod trunnion. Loosen trunnion jamnuts and position trunnion on rod as required to obtain desired adjustment.

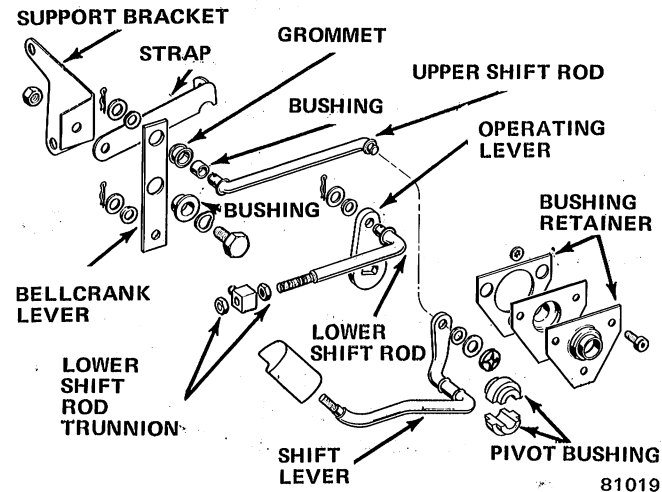
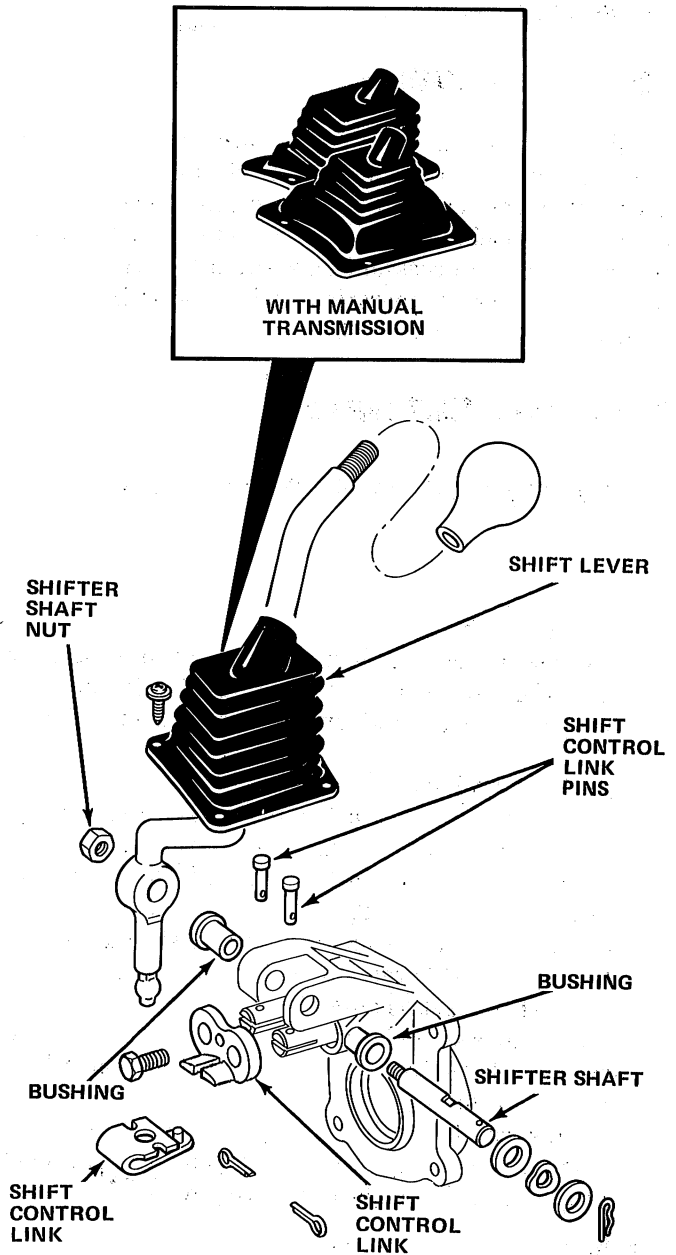

**Fig. 2D-2 Transfer Case Shift Linkage—
Cherokee-Wagoneer-Truck with Automatic Transmission**

(2) Remove shift lever knob and slide boot up and off lever.

(3) Raise vehicle.

(4) Remove shifter shaft retaining nut (fig. 2D-3).



**Fig. 2D-3 Transfer Case Shift Linkage—
CJ and Scrambler Models**

CJ and Scrambler Models—With Manual or Automatic Transmission

Removal

(1) Remove screws that attach shift lever boot to floorpan.

(5) Remove cotter pins that retain link pins in shift rods and remove link pins. Discard old cotter pins.

(6) Remove shifter shaft from shift lever.

NOTE: On some models, the shifter shaft is treaded into the shift lever and must be unthreaded to remove it. On other models, the shaft is removed simply by sliding it out of the lever and front cover bosses.

- (7) Remove shift lever.
- (8) Remove shift and shift control links from shift rods.
- (9) Clean and inspect linkage components. Replace any component that is broken, bent, cracked, or excessively worn or scored.

Installation

- (1) Install shift and shift control links.
- (2) Install shift lever.
- (3) Install shifter shaft in front cover bosses and shift lever.
- (4) Install and tighten shifter shaft retaining nut.
- (5) Install link pins in shift rods. Secure pins with new cotter pins.
- (6) Lower vehicle.
- (7) Install boot on shift lever.
- (8) Install knob on shift lever.
- (9) Position boot on floorpan and install boot attaching screws.

TRANSFER CASE REMOVAL

Cherokee-Wagoneer-Truck Models

- (1) Raise vehicle.
- (2) Drain lubricant from transfer case.
- (3) Disconnect speedometer cable and indicator switch wires and disconnect transfer case shift lever link at operating lever.
- (4) Place support stand under transmission and remove rear crossmember.
- (5) Mark transfer case front and rear output shaft yokes and propeller shafts for assembly alignment reference.
- (6) Disconnect front and rear propeller shafts at transfer case yokes. Secure shafts to frame rails with wire.
- (7) Disconnect parking brake cable guide from pivot located on right frame rail, if necessary.
- (8) Remove bolts attaching exhaust pipe support bracket-to-transfer case, if necessary.
- (9) Remove transfer case-to-transmission bolts.
- (10) Move transfer case assembly rearward until free of transmission output shaft and remove assembly.
- (11) Remove all gasket material from rear of transmission adapter housing.

CJ and Scrambler Models

- (1) On models with automatic transmission, remove shift lever knob, trim ring, and boot from transfer case shift lever.

(2) On models with manual transmission, remove shift lever knob, trim ring and boot from transmission and transfer case shift levers.

(3) Remove floor covering, if equipped, and remove transmission access cover from floorpan.

(4) Raise vehicle and drain lubricant from transfer case.

(5) Position support stand under clutch housing to support engine and transmission and remove rear crossmember.

(6) Disconnect front and rear propeller shafts at transfer case. Mark propeller shaft yokes for assembly reference.

(7) Disconnect speedometer cable at transfer case.

(8) If necessary, disconnect parking brake cable at equalizer. Disconnect exhaust pipe support bracket at transfer case, if equipped.

(9) Remove bolts attaching transfer case to transmission and remove transfer case.

TRANSFER CASE INSTALLATION

Cherokee-Wagoneer-Truck Models

(1) Align and install transfer case assembly on transmission. Be sure transfer case input gear splines are aligned with transmission output shaft. Align splines by rotating transfer case rear output shaft yoke, if necessary.

NOTE: Do not install any transfer case attaching bolts until the transfer case is completely seated against the transmission.

(2) Align and install transfer case attaching bolts. Tighten bolts to 40 foot-pounds (54 N•m) torque.

(3) Attach exhaust pipe support bracket to transfer case, if removed.

(4) Align and connect propeller shafts.

(5) Connect parking brake cable guide to pivot bracket on frame rail, if removed.

(6) Connect speedometer cable and indicator switch wires and connect transfer case shift lever link to operating lever.

(7) Install rear crossmember and remove transmission support stand.

(8) Fill transfer case with AMC/Jeep Automatic Transmission Fluid or equivalent labeled Dexron II®.

(9) Lower vehicle.

TRANSFER CASE INSTALLATION

CJ and Scrambler Models

(1) Shift transfer case to 4L position.

(2) Rotate transfer case output shaft (by turning yoke) until transmission output shaft gear engages

transfer case input shaft. Move transfer case forward until case seats against transmission.

CAUTION: Be sure the transfer case is flush against the transmission. Severe damage to the transfer case will result if the attaching bolts are tightened while the transfer case is cocked or in a bind.

(3) Install transfer case attaching bolts. Tighten bolts to 30 foot-pounds (41 N•m) torque.

(4) Fill transfer case with SAE 85W-90 gear lubricant.

(5) Connect speedometer driven gear to transfer case. Also connect transfer case shift lever and control links to transfer case shift rods.

(6) Connect front and rear propeller shafts to transfer case. Be sure to align shafts-to-yokes using reference marks made during removal. Tighten shaft-to-yoke clamp strap nuts to 16 foot-pounds (21 N•m) torque.

(7) Install rear crossmember and remove support stand from under clutch housing.

(8) Connect parking brake cable to equalizer and connect exhaust pipe support bracket to transfer case if disconnected.

(9) Lower vehicle.

(10) Install transmission access cover plate on floorpan. Install floor covering, if equipped.

(11) Install boots, trim rings, and shift knobs.

MODEL 208 TRANSFER CASE

	Page
Assembly	2D-18
Cleaning and Inspection	2D-11
Disassembly	2D-9
General	2D-6
Identification	2D-7
In-Vehicle Service	2D-8

	Page
Lubrication	2D-7
Power Flow	2D-7
Service Diagnosis	2D-7
Specifications	2D-21
Subassembly Overhaul	2D-13

GENERAL

The model 208 transfer case provides four-wheel high and low ranges, a two-wheel high range and a neutral position. The model 208 is used in Cherokee, Wagoneer and Truck models only. Models equipped with the 208 transfer case are also equipped with manual locking front drive hubs as standard equipment.

The model 208 is a chain drive unit consisting of a two-piece aluminum case containing front and rear output shafts, two drive sprockets, a shift mechanism and a planetary gear assembly. The drive sprockets are connected and operated by the drive chain. The planetary assembly which consists of a four pinion carrier and an annulus gear provide the four-wheel drive low range when engaged. Reduction ratio is 2.61:1 in low range.

Transfer Case Shift Pattern

A floor mounted shift lever is used to select the various operating ranges on all 208 models. The shift lever is located on the floorpan transmission tunnel adjacent to the transmission gearshift lever. Although the transfer case shift pattern is in a straight line for all 208 models, the range positions are different for manual and automatic transmission applications (figs. 2D-4 and 2D-5).

Four-Wheel Drive Indicator Lamp

An indicator lamp is mounted in the instrument panel

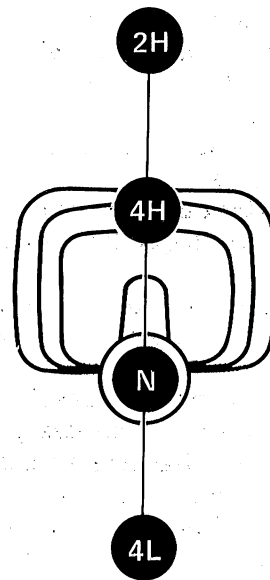
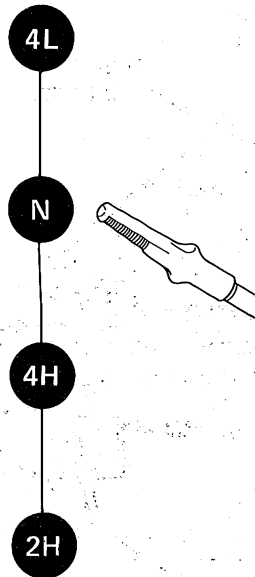

Fig. 2D-4 Model 208 Shift Pattern—Manual Transmission

to alert the driver whenever the vehicle is being operated in four-wheel high range. The lamp is controlled by an indicator switch in the transfer case (fig. 2D-6). The switch is a ball and plunger unit that is activated by the transfer case range sector when four-wheel high range is selected. The indicator lamp is illuminated in the four-wheel high range position only.



90513B

Fig. 2D-5 Model 208 Shift Pattern—Automatic Transmission

IDENTIFICATION

An identification tag is attached to the rear half of the transfer case (fig. 2D-6). This tag provides the transfer case model number, low range reduction ratio, and assembly number. The information on this tag is necessary for servicing information. If the tag is removed or becomes dislodged during service operations, it should be reattached using an adhesive sealant such as Loctite 312, or equivalent.

LUBRICATION

The model 208 transfer case lubricant should be changed at the intervals specified in the Maintenance Schedule. When adding lubricant to or refilling the transfer case after service, use AMC/Jeep Automatic Transmission Fluid or equivalent labeled Dexron II® only. Do not use any type of anti-friction type additives or similar substance. Use the specified grade of motor oil only. Refer to the In-Vehicle Service section for lubricant change procedures and fill level. Model 208 lubricant capacity is 6 pints (3 liters).

POWER FLOW

In all drive range positions input torque is transmitted to the transfer case geartrain through the transfer case input gear (fig. 2D-7).

In 2H range, torque flows from the input gear to the planetary assembly and annulus gear which rotate as a unit. Torque is transferred to the mainshaft through the planetary carrier which is splined to the mainshaft. Torque flow continues through the mainshaft and rear yoke which is splined to the mainshaft, and finally to the

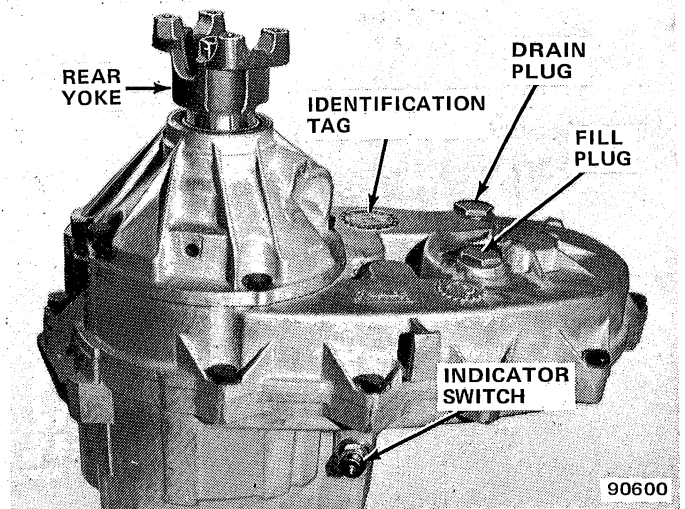

Fig. 2D-6 Model 208 Indicator Switch, Identification Tag and Drain and Fill Plug Location

rear propeller shaft and axle. In 2H range, the sliding clutch remains in a neutral position and does not lock the drive sprocket to the mainshaft. As a result, torque is not transferred to the driven sprocket.

In 4H range, input torque from the input gear is transmitted through the planetary and annulus gear and through the mainshaft in exactly the same fashion as in 2H range. However, in 4H position, the sliding clutch is shifted forward and into engagement with the mainshaft clutch gear. This locks the drive sprocket to the mainshaft through the sliding clutch. Torque is now transmitted through the drive sprocket to the driven sprocket by the connecting drive chain. Since the front output shaft is splined to the driven sprocket, torque now flows through the front output shaft to the front propeller shaft and axle resulting in high range four-wheel drive.

In 4L range, the path of torque through the transfer case is exactly the same as in 4H range but with one major difference. In 4L range, the annulus gear is shifted forward and into engagement with the lockplate. Since the lockplate is fixed in the case, the annulus gear is held stationary and does not rotate. This causes the planetary pinions to rotate about the annulus gear internal teeth producing a gear reduction ratio of 2.61:1.

SERVICE DIAGNOSIS

Before attempting to repair a suspected transfer case malfunction, check all other drive line components beforehand. The actual cause of a problem may be related to such items as the front hubs, axles, propeller shafts, wheels and tires, transmission, or clutch instead. If all other drive line components are in good condition and operating properly, refer to the Service Diagnosis charts for further information.

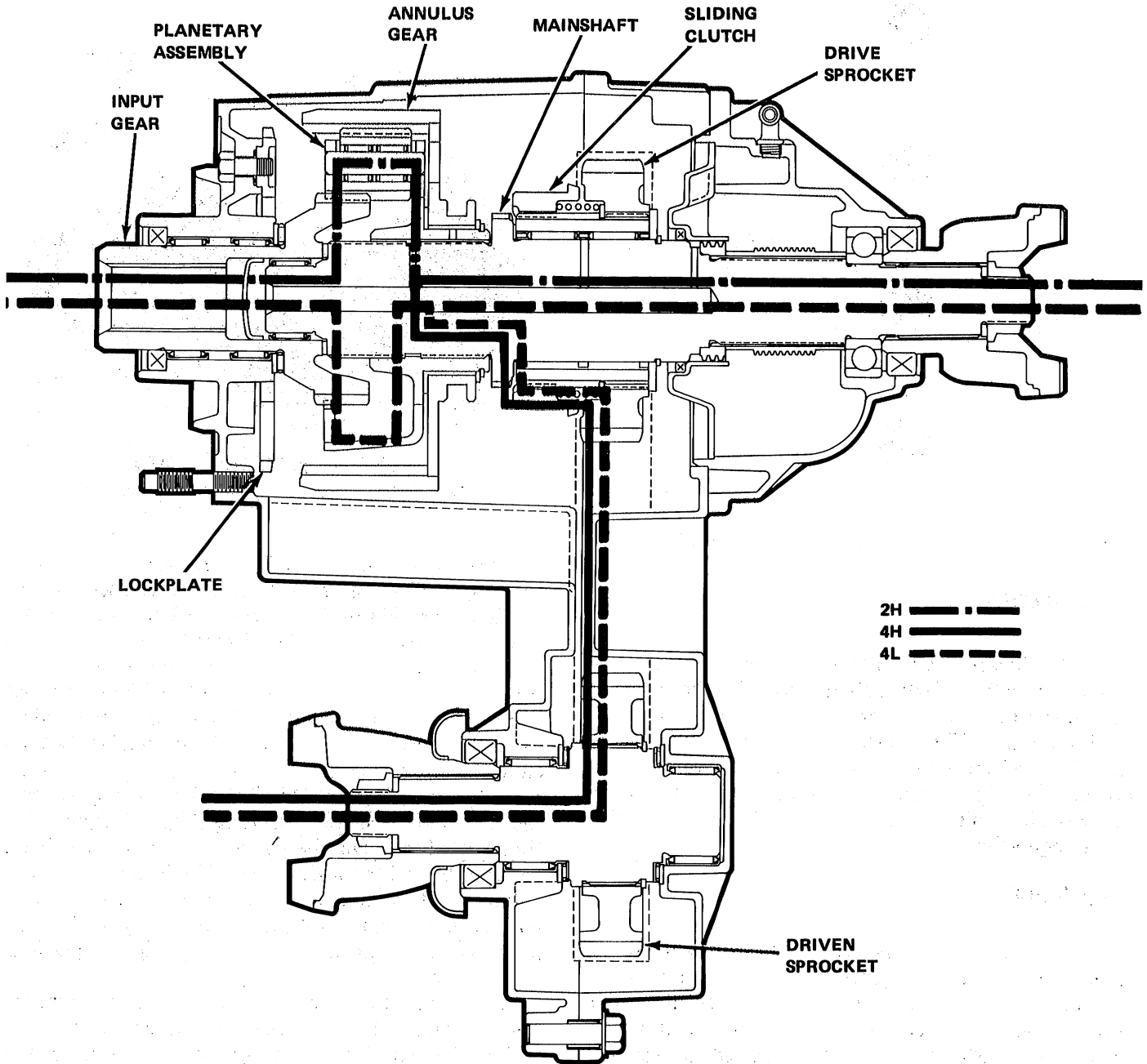

Fig. 2D-7 Power Flow—Model 208 Transfer Case

90555

IN-VEHICLE SERVICE

Changing Lubricant

- (1) Raise vehicle.
- (2) Position drain pan under transfer case.
- (3) Remove drain and fill plugs, and drain lubricant completely.
- (4) Install drain plug. Tighten plug to 35 foot-pounds (47 N•m) torque.
- (5) Remove drain pan.
- (6) Fill transfer case to edge of fill plug opening with AMC/Jeep Automatic Transmission Fluid or equivalent labeled Dexron II®.

- (7) Install fill plug. Tighten plug to 35 foot-pounds (47 N•m) torque.
- (8) Lower vehicle.

Speedometer Gear, Shaft Seal, Rear Bearing and Retainer, Oil Pump and Pump Seal Replacement

NOTE: The front and rear yokes, output shaft seals, rear retainer and bearing, oil pump, pump seal, and speedometer drive gear can all be serviced with the transfer case in the vehicle. The following combined procedure outlines removal and installation of these components.

Removal

- (1) Raise vehicle.
- (2) Remove fill and drain plugs and drain oil from transfer case.
- (3) Mark propeller shaft and transfer case yoke for assembly alignment reference.
- (4) Disconnect propeller shaft. Secure shaft to underside of vehicle.
- (5) Remove and discard transfer case yoke retaining nut and yoke seal washer. Use Tool J-8614-01 to hold yoke while removing nut.
- (6) Remove yoke. If necessary, remove yoke using Tools J-8614-01, -02 and -03.
- (7) Remove speedometer driven gear sleeve and driven gear from rear retainer.
- (8) Mark rear retainer for assembly alignment reference.
- (9) Remove retainer attaching bolts and remove retainer. Tap retainer with rawhide or plastic mallet to remove it.

CAUTION: Do not attempt to pry the retainer off the rear case. Tap the retainer loose using a rawhide or plastic mallet only.

- (10) Remove speedometer drive gear.
- (11) Remove pump housing from retainer and remove seal from housing (fig. 2D-8).
- (12) If retainer or bearing are to be replaced, remove bearing retaining snap ring from rear retainer and tap bearing out of retainer using plastic mallet.
- (13) Remove oil pump from mainshaft (fig. 2D-5).
- (14) Remove output shaft seal if seal is to be replaced.

Installation

- (1) Install oil pump on mainshaft.
- (2) Install seal in pump housing. Be sure to install seal so lip faces case interior. Lubricate seal lip with petroleum jelly or 10W-30 motor oil before installation.
- (3) Install speedometer driven gear.
- (4) Install rear output bearing in rear retainer and install snap ring. Be sure shielded side of bearing faces interior of transfer case.
- (5) Install pump housing in rear retainer.
- (6) Apply Loctite 515, or equivalent sealant, to mating surface of rear retainer.
- (7) Align retainer and case reference marks and install retainer on case.
- (8) Install and tighten retainer attaching bolts to 23 foot-pounds (31 N•m) torque.
- (9) Install output shaft seal.
- (10) Install yoke, yoke seal washer and yoke nut. Tighten nut to 120 foot-pounds (163 N•m) torque.
- (11) Install speedometer driven gear and sleeve.
- (12) Install drain plug. Tighten plug to 35 foot-pounds (47 N•m) torque.

(13) Fill transfer case to edge of fill plug opening with AMC/Jeep Automatic Transmission Fluid or equivalent labeled Dexron II®.

- (14) Install fill plug. Tighten plug to 35 foot-pounds (47 N•m) torque.
- (15) Connect propeller shaft. Tighten clamp strap bolts to 16 foot-pounds (21 N•m) torque.
- (16) Lower vehicle.

DISASSEMBLY

- (1) Remove fill and drain plugs (fig. 2D-9).
- (2) Remove front and rear yokes. Discard yoke seal washers and yoke nuts.
- (3) Turn transfer on end and position front case on wood blocks. Cut "V" case notches in wood blocks to clear mounting studs in front case if necessary.
- (4) Remove lock mode indicator switch and washer (fig. 2D-9).
- (5) Remove detent bolt, spring and ball (fig. 2D-10).
- (6) Mark rear retainer and case for assembly alignment reference.
- (7) Remove rear retainer attaching bolts and remove retainer and pump housing as assembly (fig. 2D-8). Tap retainer from case using plastic mallet only. Do not pry.
- (8) Remove pump housing from retainer and remove pump seal from housing (fig. 2D-8). Discard seal.
- (9) Remove speedometer drive gear from mainshaft.
- (10) Remove oil pump from mainshaft. Note position of pump for assembly reference. Side facing case interior has recess in it (fig. 2D-11).
- (11) Remove bolts attaching rear case to front case and remove rear case.

CAUTION: To remove the rear case, insert screwdrivers into the slots cast in the case ends and gently pry upward. Do not attempt to wedge the case halves apart at any point on the mating surfaces.

- (12) Remove front output shaft rear thrust bearing assembly (fig. 2D-12). Note position of bearing and races for assembly reference.
- (13) Remove driven sprocket retaining snap ring (fig. 2D-13).
- (14) Remove drive sprocket retaining snap ring and remove thrust washer and spacer washer, if equipped (fig. 2D-14).
- (15) Remove drive and driven sprockets and drive chain as assembly (fig. 2D-15). Lift evenly on both sprockets to remove assembly.
- (16) Remove front output shaft and front thrust bearing assembly (fig. 2D-16).
- (17) Remove sprocket carrier stop ring (fig. 2D-17).
- (18) Remove clutch spring (fig. 2D-17).
- (19) Remove sliding clutch, mode fork, mode fork spring and bracket as assembly (fig. 2D-18). Remove shift rail.

Service Diagnosis

Condition	Possible Cause	Correction
<p>TRANSFER CASE DIFFICULT TO SHIFT OR WILL NOT SHIFT INTO DESIRED RANGE</p>	<p>(1) Vehicle speed too great to permit shifting.</p> <p>(2) If vehicle was operated for extended period in 4H mode on dry paved surface, driveline torque load may cause difficult shifting.</p> <p>(3) Transfer case external shift linkage binding.</p> <p>(4) Insufficient or incorrect lubricant.</p> <p>(5) Internal components binding, worn, or damaged.</p>	<p>(1) Stop vehicle and shift into desired range. Or reduce speed to 2-3 mph (3-4 km/h) before attempting to shift.</p> <p>(2) Stop vehicle, shift transmission to neutral, shift transfer case to 2H mode and operate vehicle in 2H on dry paved surfaces.</p> <p>(3) Lubricate or repair or replace linkage, or tighten loose components as necessary.</p> <p>(4) Drain and refill to edge of fill hole with Jeep, Dextron II Automatic transmission fluid only.</p> <p>(5) Disassemble unit and replace worn or damaged components as necessary.</p>
<p>TRANSFER CASE NOISY IN ALL DRIVE MODES</p>	<p>(1) Insufficient or incorrect lubricant.</p>	<p>(1) Drain and refill to edge of fill hole with Jeep, Dextron II Automatic transmission fluid only. Check for leaks and repair if necessary. Note: If unit is still noisy after drain and refill; disassembly and inspection may be required to locate source of noise.</p>
<p>NOISY IN — OR JUMPS OUT OF FOUR WHEEL DRIVE LOW RANGE</p>	<p>(1) Transfer case not completely engaged in 4L position.</p> <p>(2) Shift linkage loose or binding.</p> <p>(3) Range fork cracked, inserts worn, or fork is binding on shift rail.</p> <p>(4) Annulus gear or lockplate worn or damaged.</p>	<p>(1) Stop vehicle, shift transfer case in Neutral, then shift back into 4L position.</p> <p>(2) Tighten, lubricate, or repair linkage as necessary.</p> <p>(3) Disassemble unit and repair as necessary.</p> <p>(4) Disassemble unit and repair as necessary.</p>

Service Diagnosis (Continued)

Condition	Possible Cause	Correction
LUBRICANT LEAKING FROM OUTPUT SHAFT SEALS OR FROM VENT	(1) Transfer case overfilled. (2) Vent closed or restricted. (3) Output shaft seals damaged or installed incorrectly.	(1) Drain to correct level. (2) Clear or replace vent if necessary. (3) Replace seals. Be sure seal lip faces interior of case when installed. Also be sure yoke seal surfaces are not scored or nicked. Remove scores, nicks with fine sandpaper or replace yoke(s) if necessary.
ABNORMAL TIRE WEAR	(1) Extended operation on dry hard surface (paved) roads in 4H range.	(1) Operate in 2H on hard surface (paved) roads.

90770B

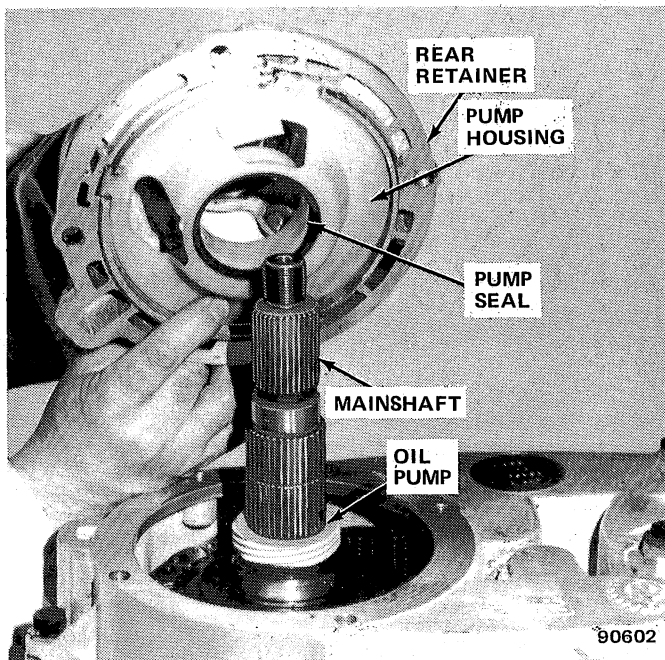

Fig. 2D-8 Rear Retainer Removal/Installation

(20) Remove sprocket carrier, needle bearing upper retainer, thrust washer and mainshaft needle bearings as assembly (fig. 2D-19).

(21) Remove mainshaft (fig. 2D-20).

(22) Remove annulus gear retaining ring and thrust washer (fig. 2D-20).

(23) Remove annulus gear and range fork as assembly. Turn fork counterclockwise to disengage fork lug from range sector and lift assembly out of case (fig. 2D-21).

(24) Remove planetary thrust washer and remove planetary assembly (fig. 2D-22).

(25) Remove mainshaft thrust bearing from input gear (fig. 2D-23) and remove input gear. Lift gear straight up and out of case.

(26) Remove input gear thrust bearing and race (fig. 2D-24). Note position of bearing and race for assembly reference.

(27) Remove range sector operating lever attaching nut and washer. Remove lever and remove sector shaft and seal retainer (fig. 2D-9).

(28) Remove range sector.

(29) Inspect lockplate (fig. 2D-24). If lockplate is loose or is worn, broken or cracked, remove lockplate. Refer to replacement procedure in Subassembly Overhaul section.

(30) Remove output shaft seals from front and rear case seal bores.

CLEANING AND INSPECTION

Wash all parts thoroughly in clean solvent. Be sure all old lubricant, metallic particles, dirt, or foreign material are removed from the surfaces of every part. Apply compressed air to each oil feed port and channel in each case half to remove any obstructions or cleaning solvent residue.

Inspect all gear teeth for signs of excessive wear or damage and check all gear splines for burrs, nicks, wear or damage. Remove minor nicks or scratches on oil stone. Replace any part exhibiting excessive wear or damage.

Inspect all snap rings and thrust washers for evidence of excessive wear, distortion, or damage. Replace any of these parts if they exhibit these conditions.

Inspect the two case halves for cracks, porosity, damaged mating surfaces, stripped bolt threads, or distortion. Replace any part that exhibits these conditions.

Inspect the low range lockplate in the front case. If the lockplate teeth or the plate hub is cracked, broken, chipped, or excessively worn, replace the lockplate and the lockplate attaching bolts. Refer to the Low Range Lockplate Replacement procedure in the Subassembly Overhaul section.

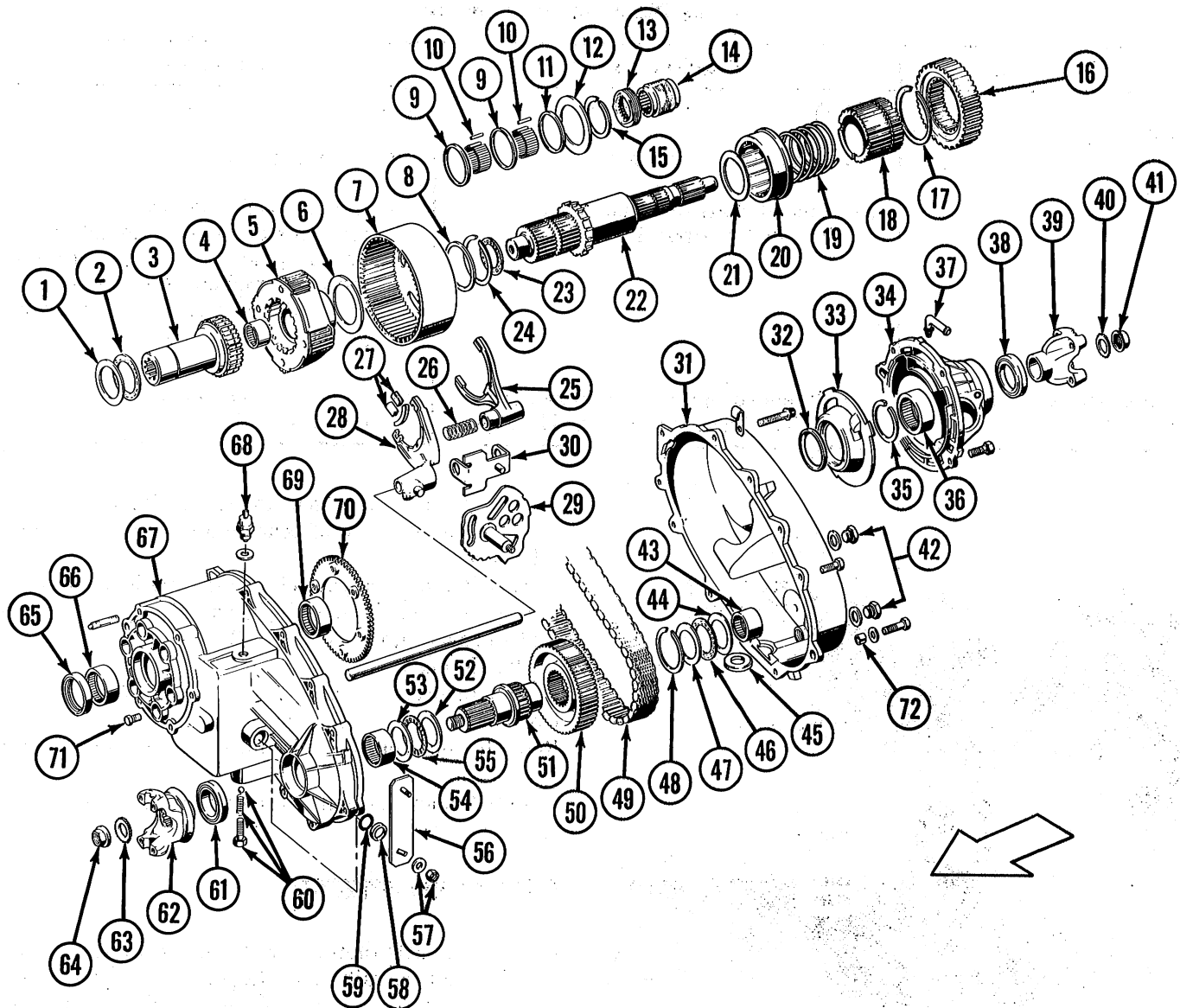

- | | |
|---|--|
| <ul style="list-style-type: none"> 1. INPUT GEAR THRUST WASHER 2. INPUT GEAR THRUST BEARING 3. INPUT GEAR 4. MAINSHAFT PILOT BEARING 5. PLANETARY ASSEMBLY 6. PLANETARY THRUST WASHER 7. ANNULUS GEAR 8. ANNULUS GEAR THRUST WASHER 9. NEEDLE BEARING SPACERS 10. MAINSHAFT NEEDLE BEARINGS (120) 11. NEEDLE BEARING SPACER 12. THRUST WASHER 13. OIL PUMP 14. SPEEDOMETER GEAR 15. DRIVE SPROCKET RETAINING RING 16. DRIVE SPROCKET 17. SPROCKET CARRIER STOP RING 18. SPROCKET CARRIER 19. CLUTCH SPRING 20. SLIDING CLUTCH 21. THRUST WASHER 22. MAINSHAFT 23. MAINSHAFT THRUST BEARING 24. ANNULUS GEAR RETAINING RING 25. MODE FORK 26. MODE FORK SPRING 27. RANGE FORK INSERTS 28. RANGE FORK 29. RANGE SECTOR | <ul style="list-style-type: none"> 30. MODE FORK BRACKET 31. REAR CASE 32. SEAL 33. PUMP HOUSING 34. REAR RETAINER 35. REAR OUTPUT BEARING 36. BEARING SNAP RING 37. VENT TUBE 38. REAR SEAL 39. REAR YOKE 40. YOKE SEAL WASHER 41. YOKE NUT 42. DRAIN AND FILL PLUGS 43. FRONT OUTPUT SHAFT REAR BEARING 44. FRONT OUTPUT SHAFT REAR THRUST BEARING RACE (THICK) 45. CASE MAGNET 46. FRONT OUTPUT SHAFT REAR THRUST BEARING 47. FRONT OUTPUT SHAFT REAR THRUST BEARING RACE (THIN) 48. DRIVEN SPROCKET RETAINING RING 49. DRIVE CHAIN 50. DRIVEN SPROCKET 51. FRONT OUTPUT SHAFT 52. FRONT OUTPUT SHAFT FRONT THRUST BEARING RACE (THIN) 53. FRONT OUTPUT SHAFT FRONT THRUST BEARING RACE (THICK) 54. FRONT OUTPUT SHAFT FRONT BEARING 55. FRONT OUTPUT SHAFT FRONT THRUST BEARING 56. OPERATING LEVER 57. WASHER AND LOCKNUT 58. RANGE SECTOR SHAFT SEAL RETAINER 59. RANGE SECTOR SHAFT SEAL 60. DETENT BALL, SPRING AND RETAINER BOLT 61. FRONT SEAL 62. FRONT YOKE 63. YOKE SEAL WASHER 64. YOKE NUT 65. INPUT GEAR OIL SEAL 66. INPUT GEAR FRONT BEARING 67. FRONT CASE 68. LOCK MODE INDICATOR SWITCH AND WASHER 69. INPUT GEAR REAR BEARING 70. LOCKPLATE 71. LOCKPLATE BOLTS 72. CASE ALIGNMENT DOWELS |
|---|--|

Fig. 2D-9 Model 208 Transfer Case

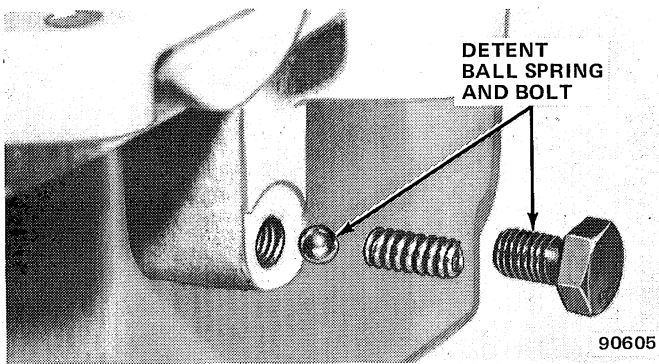

Fig. 2D-10 Detent Ball, Spring and Bolt Removal/Installation

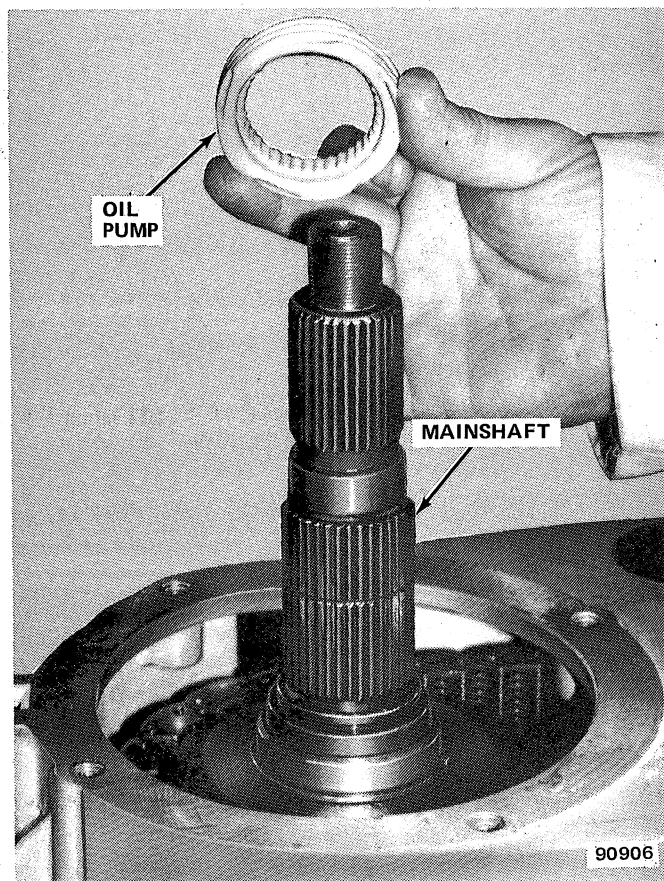

Fig. 2D-11 Oil Pump Removal/Installation

Inspect the condition of all needle, roller, ball and thrust bearings in the front and rear case halves and the input gear. Also check the condition of the bearing bores in both cases and in the input gear, rear output shaft, side gear, and rear retainer. Replace any part that exhibits signs of excessive wear or damage. If the case or input gear bearings require replacement, refer to Bearing Replacement in the Subassembly Overhaul section.

SUBASSEMBLY OVERHAUL

Lockplate Replacement

(1) Remove and discard lockplate attaching bolts.



Fig. 2D-12 Front Output Shaft Rear Thrust Bearing Assembly Removal/Installation

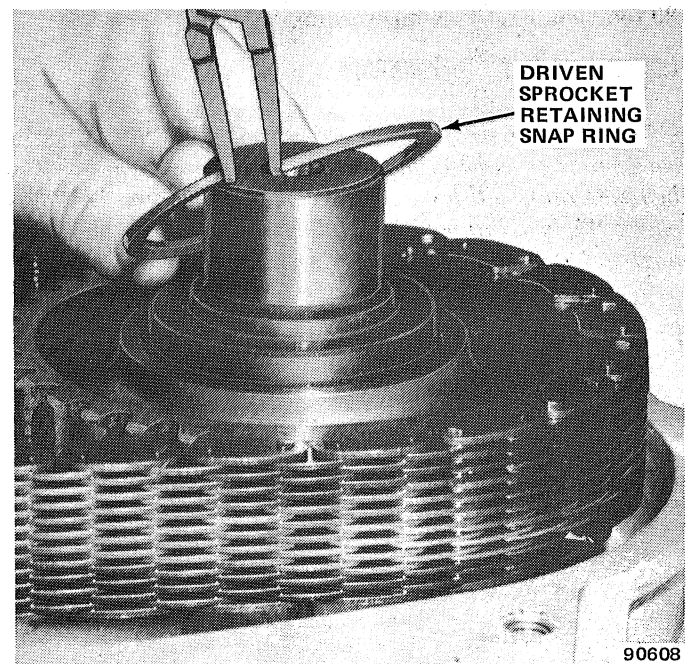

Fig. 2D-13 Driven Sprocket Retaining Snap Ring Removal/Installation

(2) Remove lockplate from case.

(3) Coat case and lockplate surfaces around bolt holes with Loctite 515, or equivalent sealant.

(4) Position new lockplate in case and align bolt holes in lockplate and case.

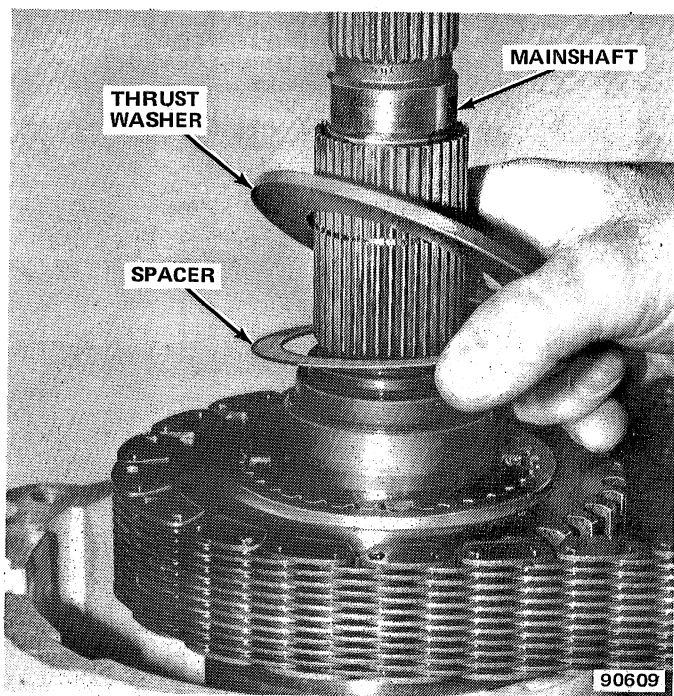

Fig. 2D-14 Drive Sprocket Thrust Washer and Spacer Removal/Installation

(5) Coat new lockplate attaching bolts with Loctite 271, or equivalent adhesive sealant.

(6) Install and tighten lockplate attaching bolts to 30 foot-pounds (41 N•m) torque.

Bearing/Bushing Replacement

CAUTION: All of the bearings used in the transfer case must be correctly positioned to avoid covering the bearing oil feed holes. After replacing any bearings check the bearing position to be sure the feed hole is not obstructed or blocked by the bearing.

Rear Output Bearing and Rear Seal Replacement

(1) Remove bearing retaining snap ring and tap bearing out of retainer using mallet or brass drift.

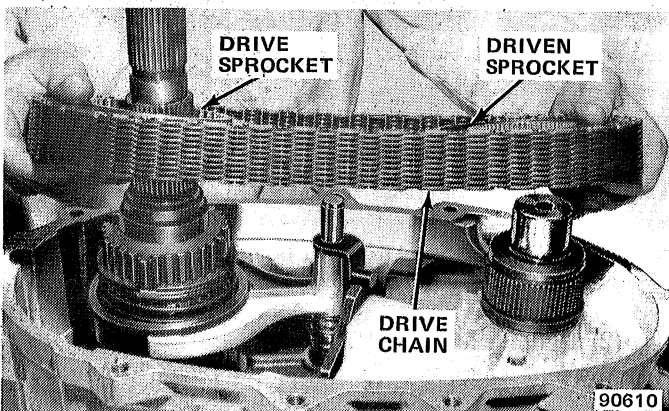

Fig. 2D-15 Sprocket and Chain Removal/Installation

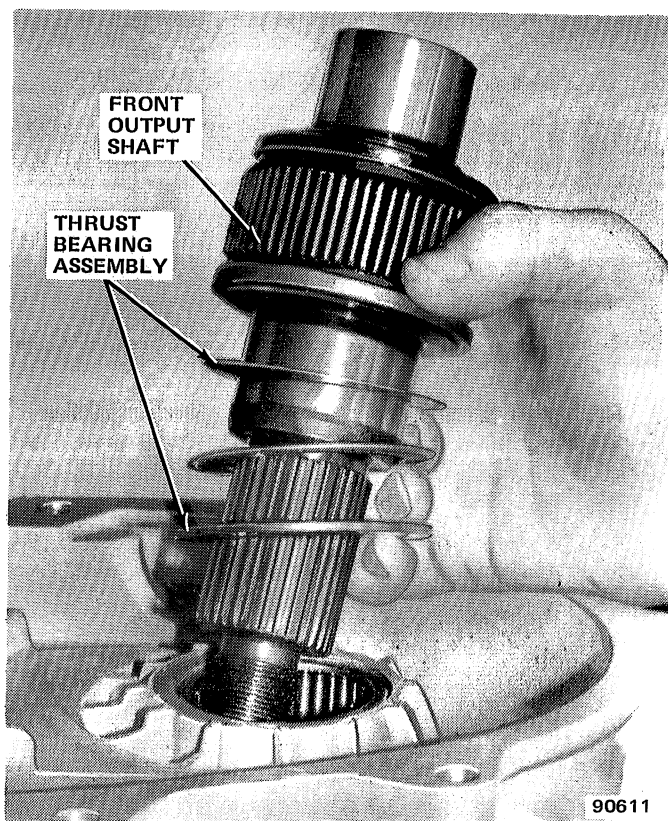

Fig. 2D-16 Front Output Shaft and Front Thrust Bearing Assembly — Removal/Installation

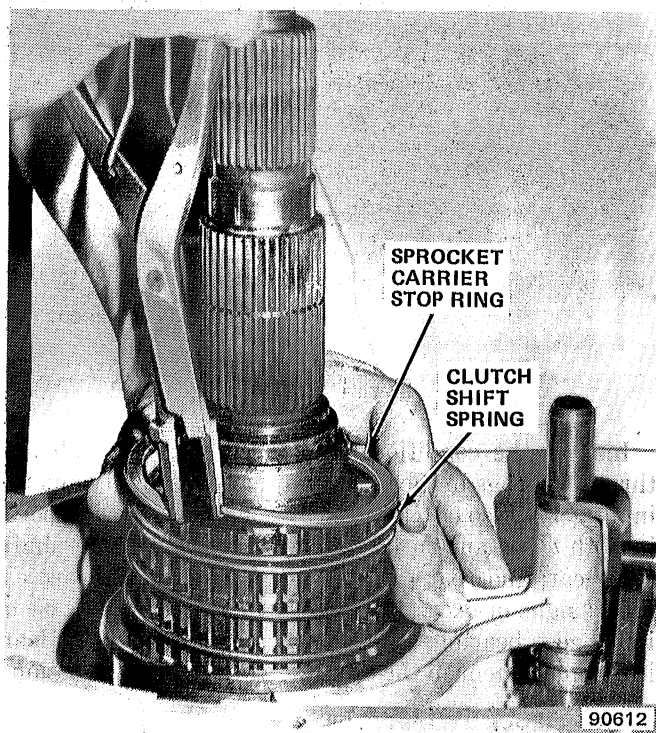

Fig. 2D-17 Sprocket Carrier Stop Ring and Clutch Spring Removal/Installation

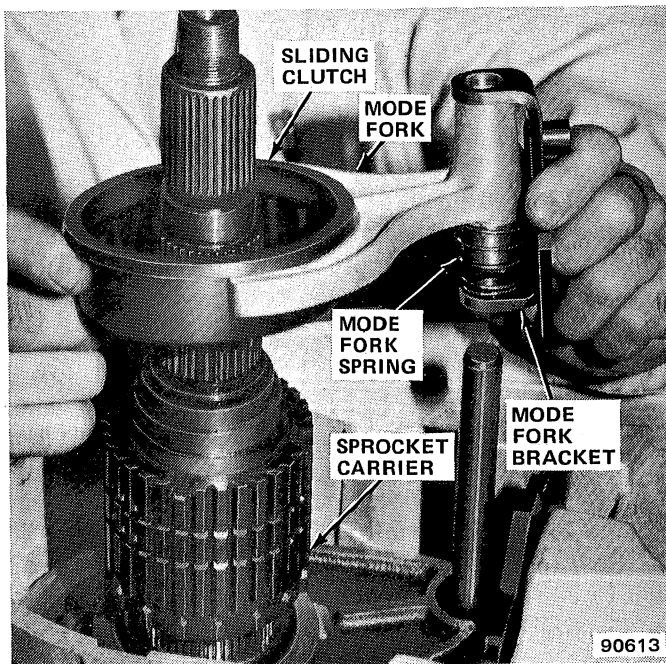

Fig. 2D-18 Mode Fork, Spring, Bracket and Sliding Clutch Removal/Installation

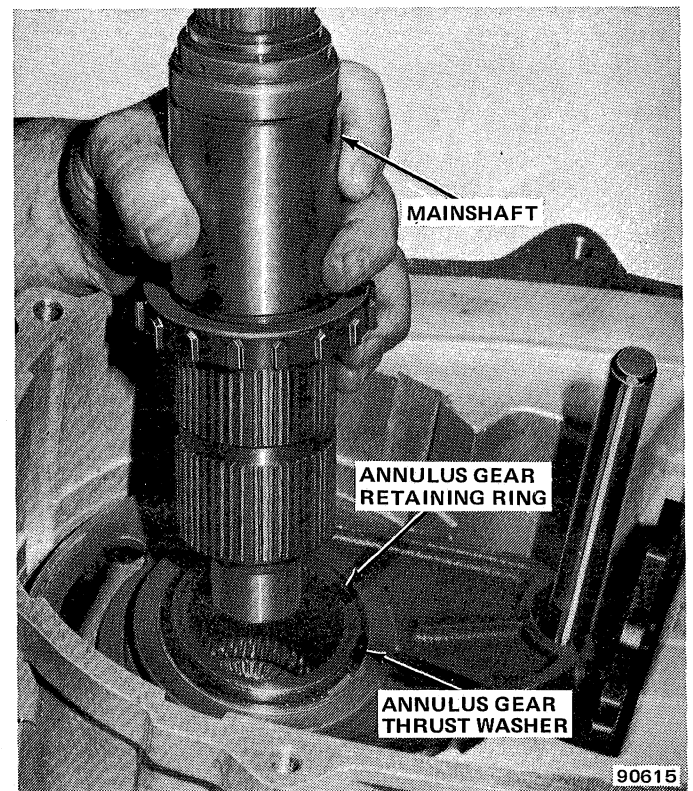

Fig. 2D-20 Mainshaft Removal/Installation

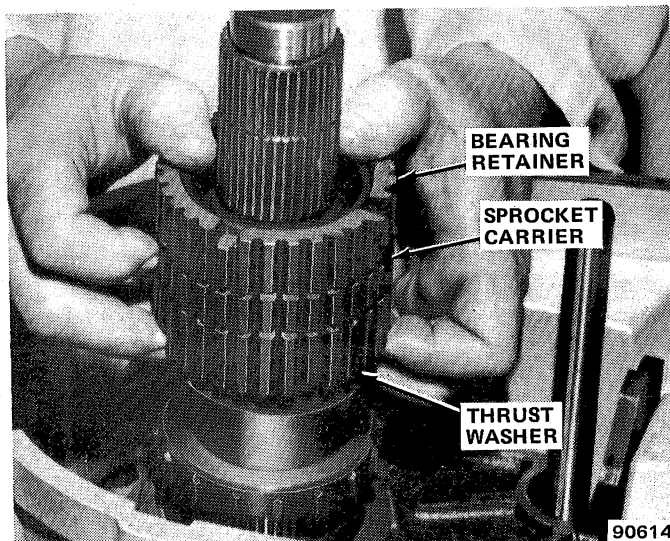

Fig. 2D-19 Sprocket Carrier, Bearing Retainers, Thrust Washer and Needle Bearing Removal

(2) Remove rear seal using screwdriver or brass drift.

(3) Install new bearing using Tool J-7818 (fig. 2D-25). Be sure shielded side of bearing faces interior of case.

(4) Install bearing retaining snap ring.

(5) Install new rear seal using Tools J-8092 and J-29162 (fig. 2D-26).

Front Output Shaft Front Bearing Replacement

(1) Remove bearing using Tools J-8092 and J-29168 (fig. 2D-27).

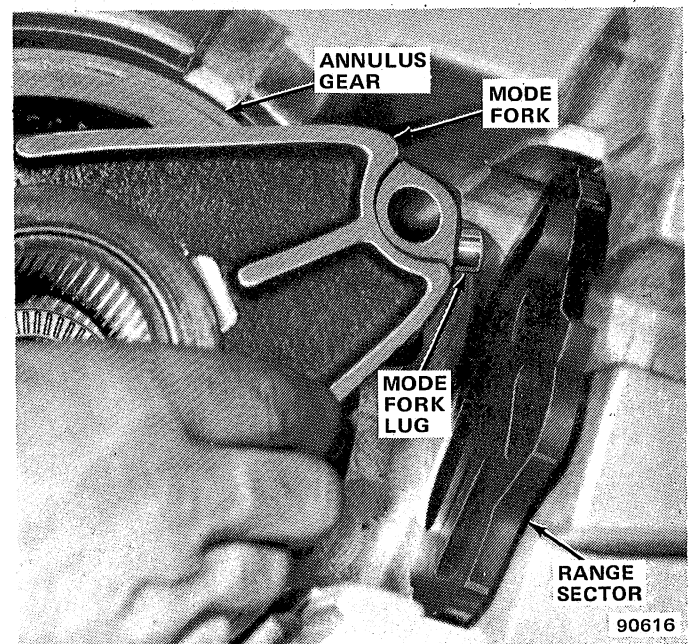

Fig. 2D-21 Annulus Gear and Mode Fork Removal/Installation

(2) Install new bearing using Tools J-8092 and J-29167 (fig. 2D-28).

(3) Remove installer tools and check bearing position to be sure oil feed hole is not covered.

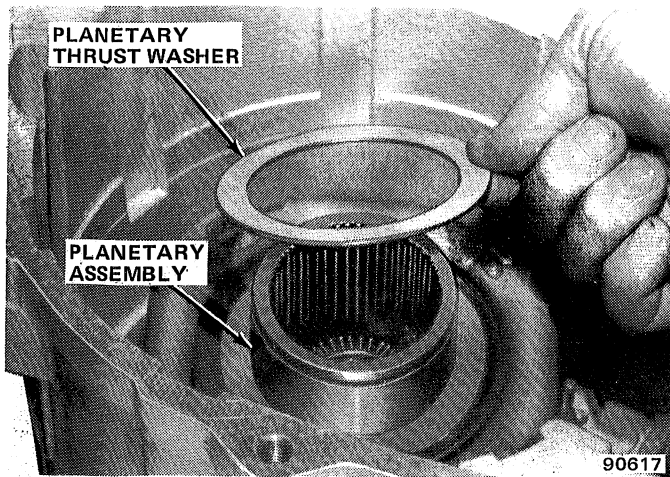

Fig. 2D-22 Planetary Thrust Washer and Planetary Assembly

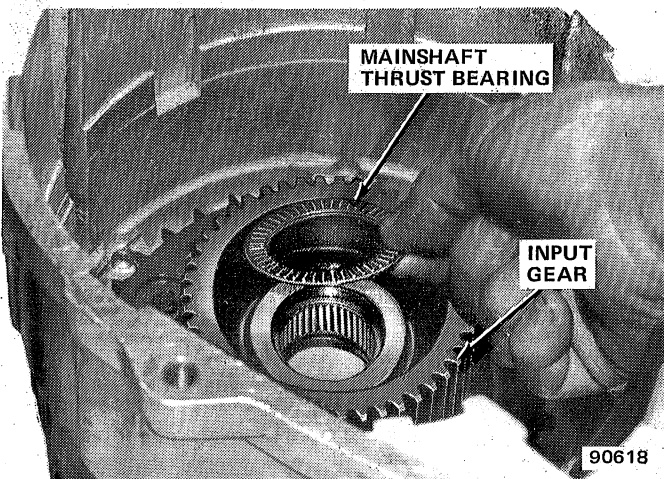

Fig. 2D-23 Mainshaft Thrust Bearing and Input Gear

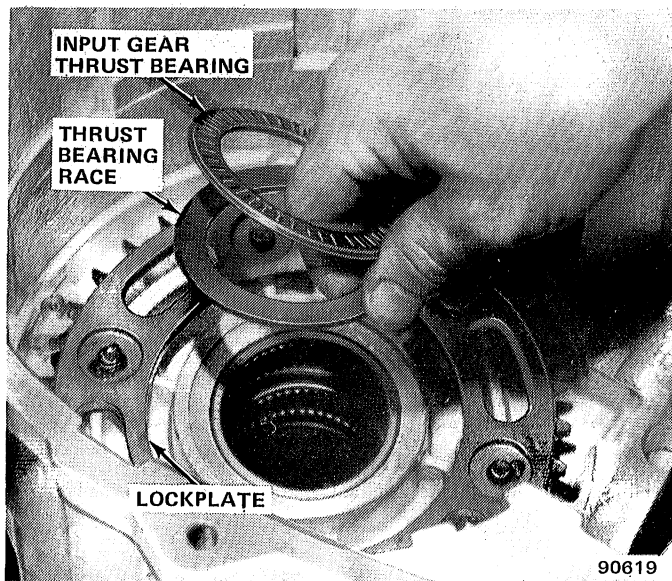

Fig. 2D-24 Input Gear Thrust Bearing and Race Removal—Installation

Front Output Shaft Rear Bearing Replacement

- (1) Remove bearing using Remover J-26941 and Slide Hammer J-2619-01 (fig. 2D-29).
- (2) Install new bearing using Driver Handle J-8092 and Installer J-29163 (fig. 2D-30).
- (3) Remove installer tools and check bearing position to be sure oil feed hole is not covered. Also be sure bearing is seated flush with edge of case bore to allow room for thrust bearing assembly.

Input Gear Front/Rear Bearing Replacement

- (1) Remove both bearings simultaneously using Driver Handle J-8092 and Remover J-29170 (fig. 2D-31).
- (2) Install new bearings one at a time. Install rear bearing first; then install front bearing. Use Driver Handle J-8092 and Installer J-29169 (fig. 2D-32).
- (3) Remove installer tools and check bearing position to be sure oil feed holes are not covered. Also be sure bearings are flush with case bore surfaces.

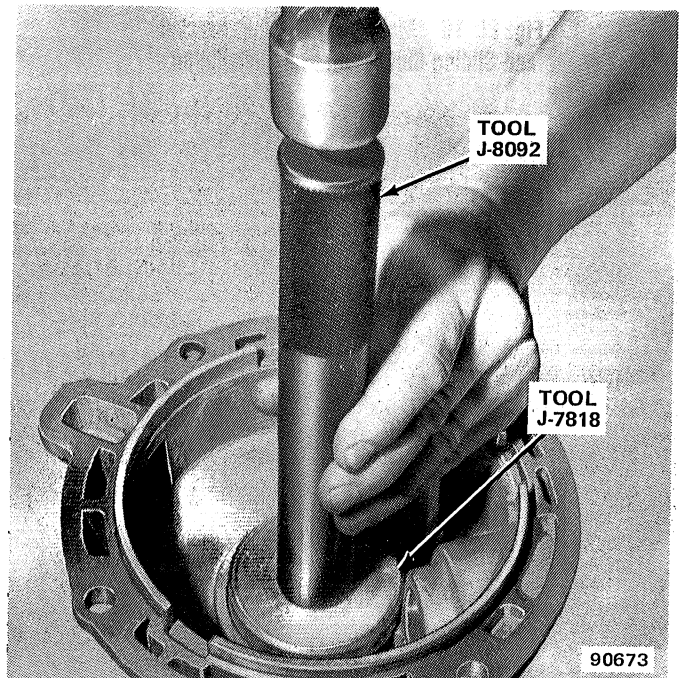

Fig. 2D-25 Rear Output Bearing Installation

Mainshaft Pilot Bearing Replacement

- (1) If bearing cannot be removed by hand, remove it using Slide Hammer J-2619-01 and Remover J-29369-1 or similar internal type blind hole bearing puller (fig. 2D-33).
- (2) If necessary, install new bearing using Driver Handle J-8092 and Installer J-29174 (fig. 2D-34).
- (3) If bearing was seated using installer tools, check bearing position to be sure hole feed hole is not covered. Also be sure bearing is seated flush with edge of bearing bore.

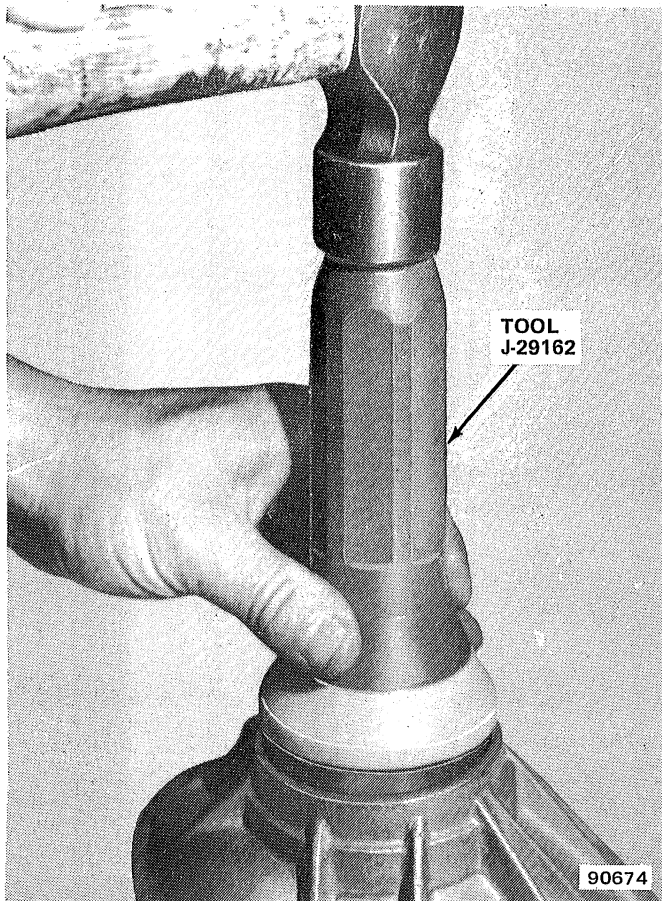

Fig. 2D-26 Rear Seal Installation

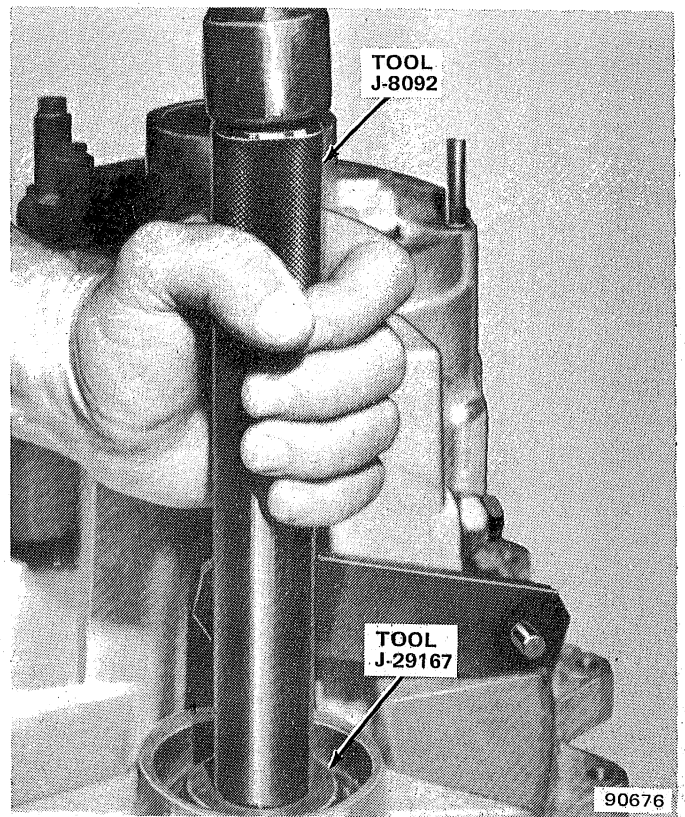

Fig. 2D-28 Front Output Shaft Front Bearing Installation

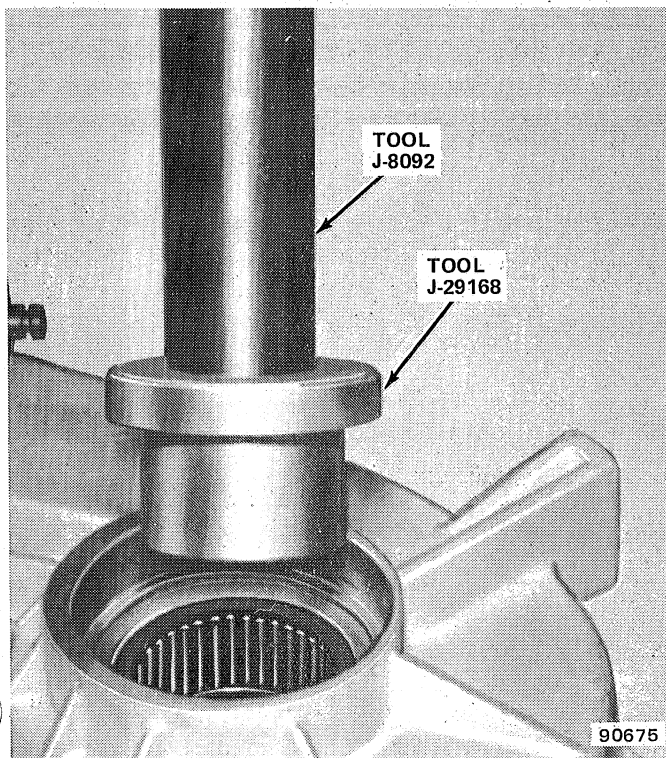

Fig. 2D-27 Front Output Shaft Front Bearing Removal

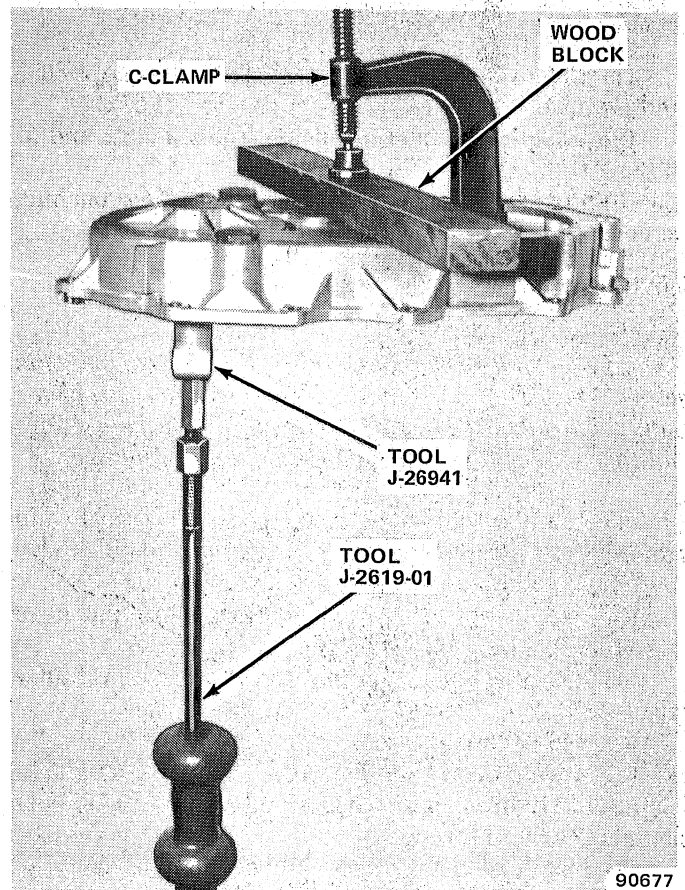

Fig. 2D-29 Front Output Shaft Rear Bearing Removal

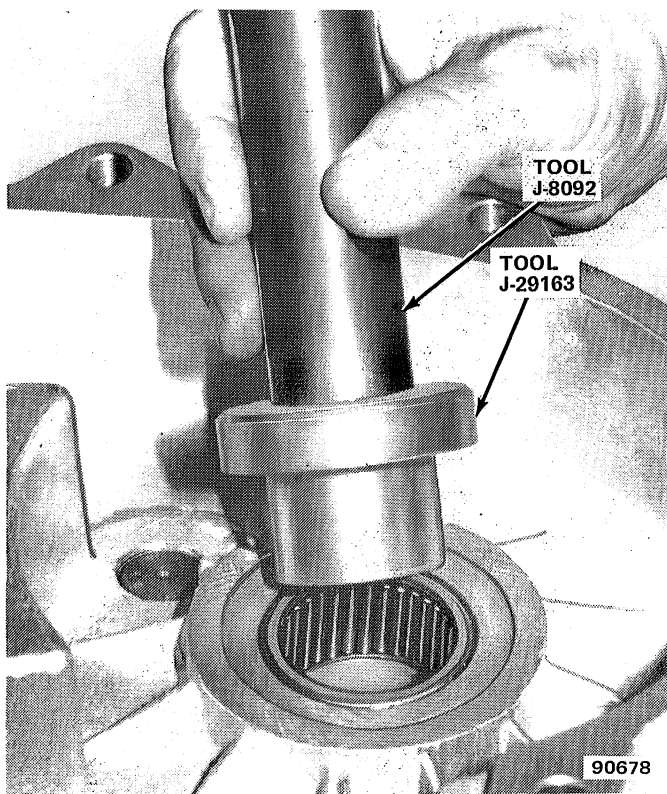

Fig. 2D-30 Front Output Shaft Rear Bearing Installation

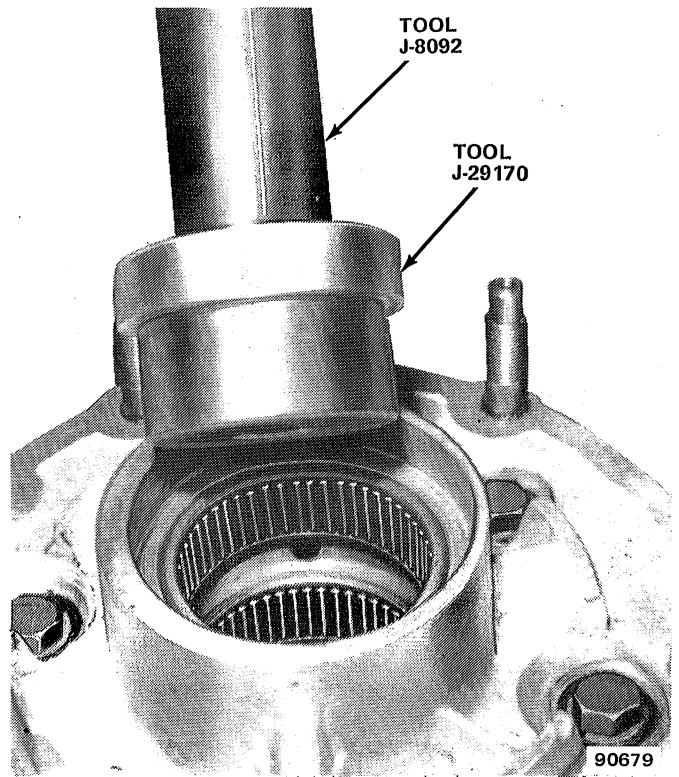

Fig. 2D-31 Input Gear Bearing Removal

Annulus Gear Bushing Replacement

(1) Remove bushing using Driver Handle J-8092 and Remover/Installer Tool J-29185 (fig. 2D-35).

(2) Install new bushing using Tools J-8092 and J-29185-2 (fig. 2D-36).

(3) Remove any chips generated by bushing removal/installation.

ASSEMBLY

NOTE: During assembly, lubricate all components with AMC/Jeep Automatic Transmission Fluid or equivalent labeled Dexron II® or petroleum jelly where indicated only. Do not use any other type of lubricants.

(1) Install input gear race and thrust bearing in front case (fig. 2D-24).

(2) Install input gear.

(3) Install mainshaft thrust bearing in input gear (fig. 2D-37).

(4) Install range sector shaft seal and seal retainer (fig. 2D-9).

(5) Install range sector.

(6) Install operating lever on range sector shaft. Install and tighten shaft washer and locknut to 18 foot-pounds (24 N•m) torque.

(7) Install planetary assembly over input gear (fig. 2D-37). Be sure planetary is fully seated and meshed with gear.

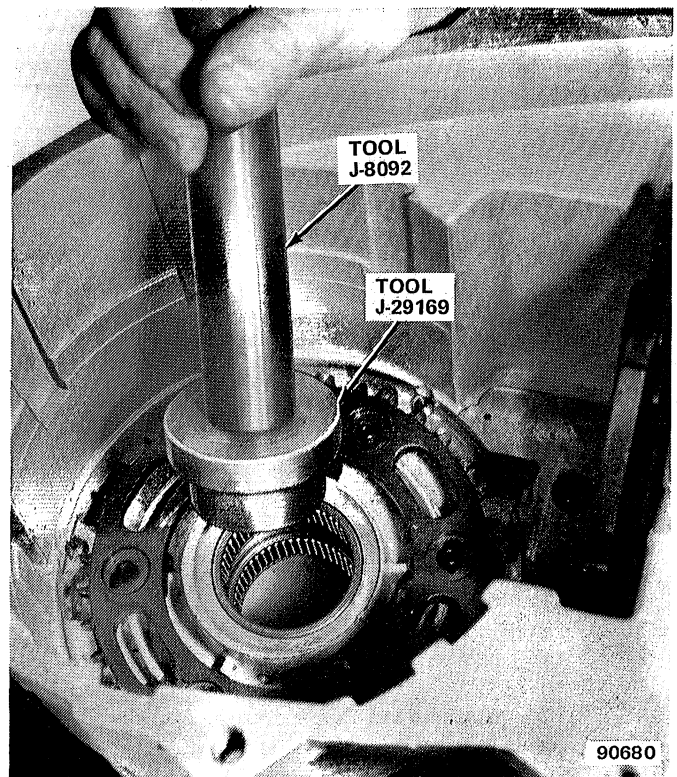

Fig. 2D-32 Input Gear Bearing Installation

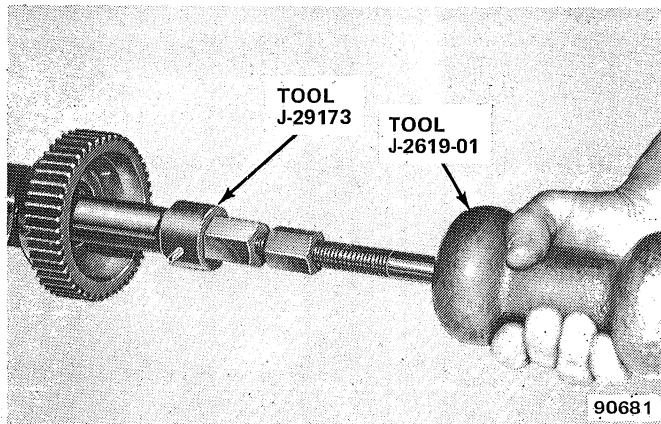

Fig. 2D-33 Mainshaft Pilot Bearing Removal

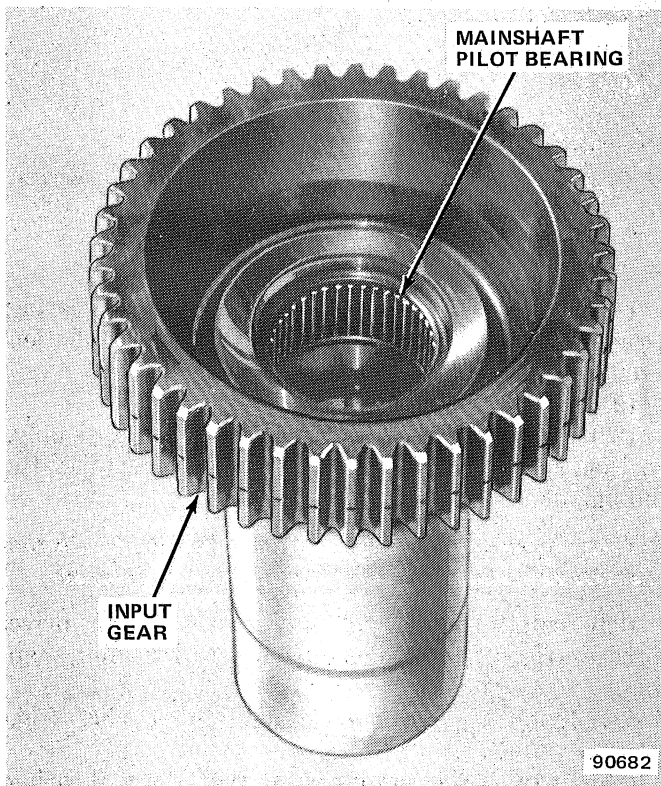

Fig. 2D-34 Mainshaft Pilot Bearing Installation

(8) Install planetary thrust washer on planetary hub (fig. 2D-22).

(9) Install inserts in range fork, if removed.

(10) Engage range fork in annulus gear and install annulus gear over planetary assembly (fig. 2D-38).

NOTE: Be sure the range fork lug is fully inserted in the range sector slot (fig. 2D-21).

(11) Install annulus gear thrust washer and retaining snap ring (fig. 2D-20).

(12) Align shift rail bores in case and range fork and install shift rail (2D-38).

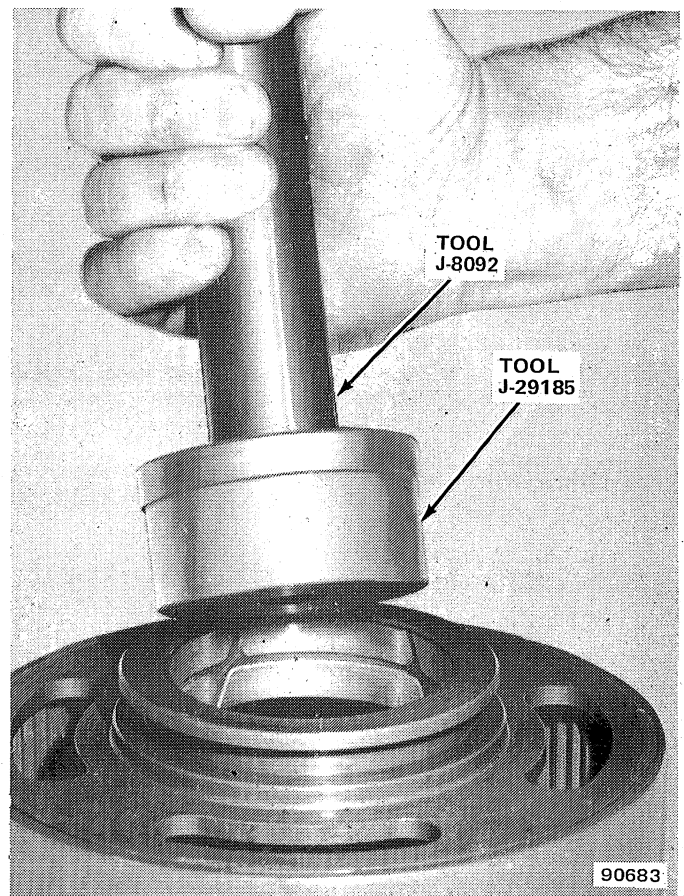

Fig. 2D-35 Annulus Gear Bushing Removal

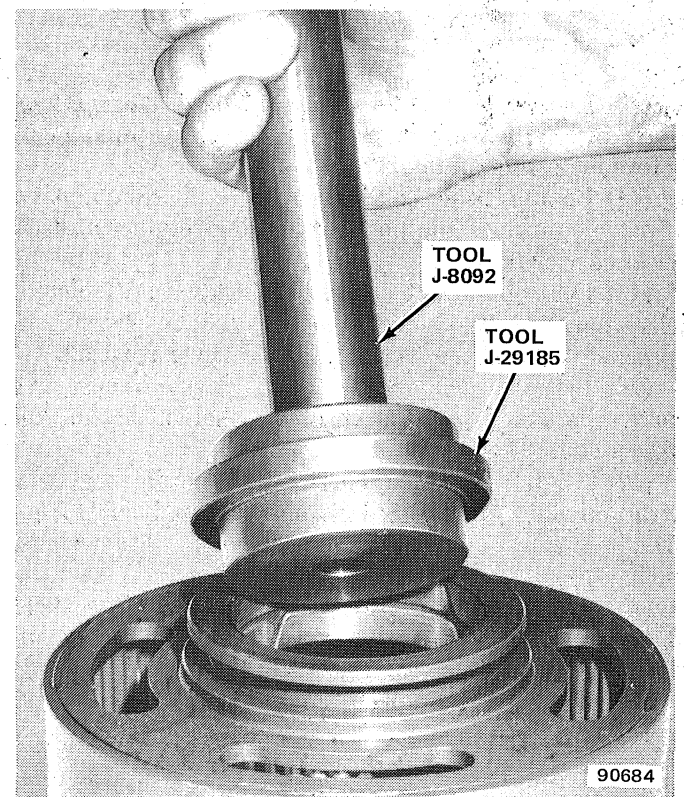

Fig. 2D-36 Annulus Gear Bushing Installation

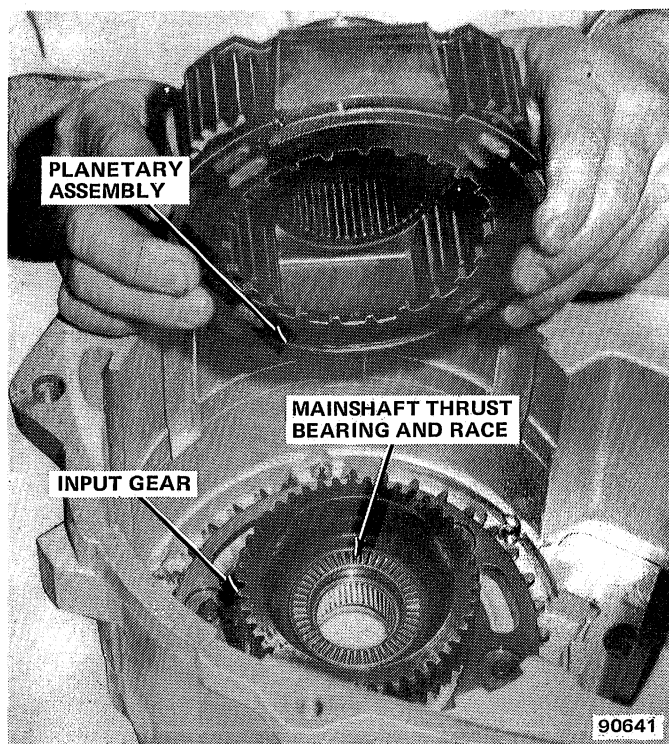

Fig. 2D-37 Input Gear, Mainshaft Thrust Bearing and Planetary Installation

CAUTION: *The shift rail bore in the case must be completely dry and not contain any oil. A small amount of oil may prevent the rail from seating completely and also prevent front case installation.*

(13) Install mainshaft (fig. 2D-20). Be sure mainshaft thrust bearing is properly seated in input gear before installing mainshaft.

(14) Coat sprocket carrier bore with liberal quantity of petroleum jelly and position bearing retainer at center of carrier bore.

(15) Coat mainshaft needle bearings with petroleum jelly and install 60 needle bearings in each end of sprocket carrier bore. Total of 120 bearings are used.

(16) Install bearing retainer in each end of sprocket carrier bore and position thrust washer on bottom of carrier (fig. 2D-39).

(17) Align assembled carrier and needle bearings with mainshaft and install assembly on mainshaft (fig. 2D-16). Take care to avoid displacing needle bearings during installation.

(18) Assemble mode fork, fork spring and bracket. Engage fork in sliding clutch and install assembly on shift rail and mainshaft (fig. 2D-18).

(19) Install clutch spring and stop ring on sprocket carrier (fig. 2D-17).

NOTE: *If the sprocket carrier has two ring grooves, install the stop ring in the upper groove only.*

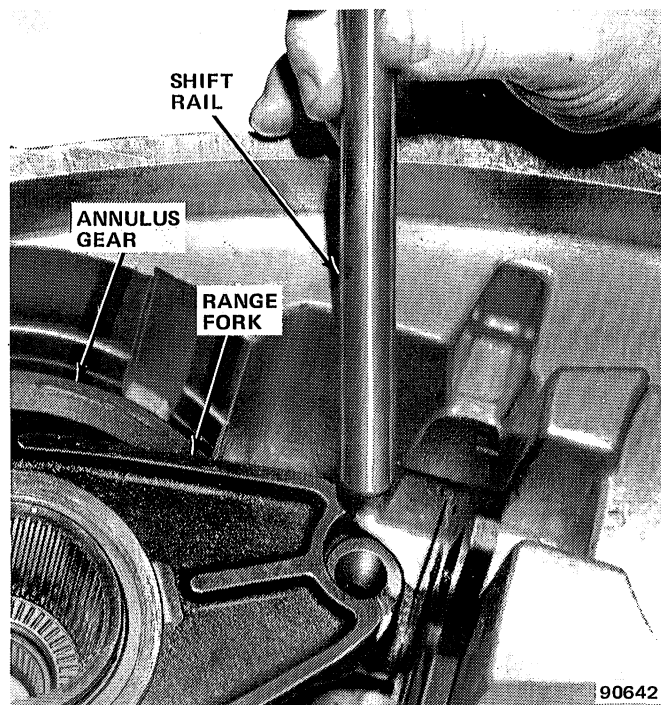

Fig. 2D-38 Annulus Gear and Shift Rail Installation

(20) Install front output shaft front thrust bearing assembly in front case (fig. 2D-16). Correct installation sequence is thick race-thrust bearing-thin race.

(21) Install front output shaft.

(22) Install sprockets and drive chain as assembly. Position sprockets in chain, align sprockets with shafts and install assembly (fig. 2D-15).

NOTE: *Be sure the drive sprocket is installed with the recessed side of the sprocket facing the case interior.*

(23) Install spacer and thrust washer on drive sprocket (fig. 2D-14) and install sprocket retaining snap ring.

(24) Install driven sprocket retaining ring (fig. 2D-13).

(25) Install front output shaft rear thrust bearing assembly on front output shaft (fig. 2D-12). Correct installation sequence is thin race-thrust bearing-thick race.

(26) Install oil pump on mainshaft. Be sure recessed side of pump faces downward toward case interior.

(27) Install speedometer drive gear on mainshaft.

(28) Install magnet in front case, if removed.

(29) Apply Loctite 515, or equivalent sealant, to mating surface of front case and install rear case on front case.

CAUTION: *Be sure front output shaft rear thrust bearing assembly is seated in the rear case.*

(30) Align case bolt holes and alignment dowels and install bolts. Tighten bolts alternately and evenly to 23 foot-pounds (31 N•m) torque.

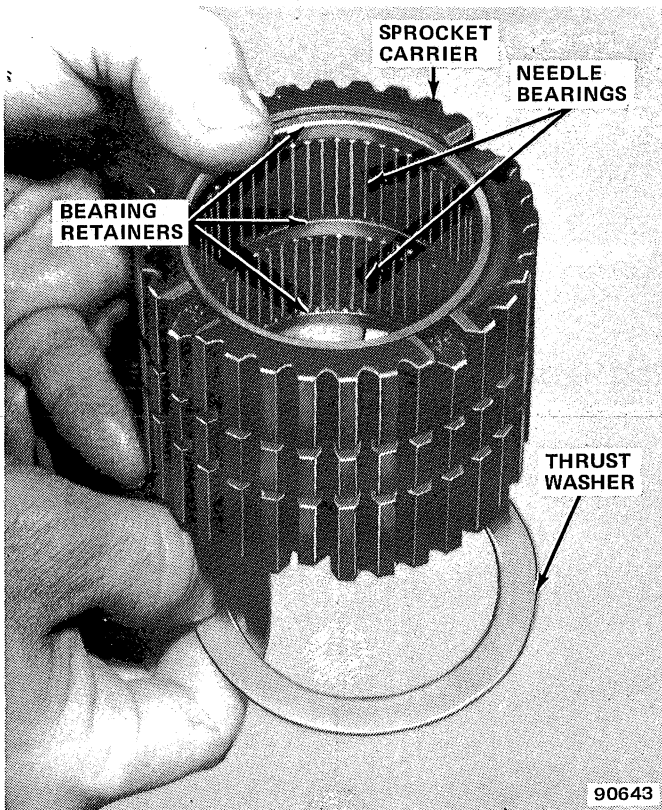

Fig. 2D-39 Assembling Sprocket Carrier Components

NOTE: Be sure to install flat washers on the two bolts installed at the opposite ends of the case.

- (31) Install rear output bearing in rear retainer and install snap ring.
- (32) Install seal in pump housing. Apply petroleum jelly to pump housing tabs and install housing in rear retainer.
- (33) Apply Loctite 515, or equivalent sealant, to mating surface of rear retainer.

- (34) Align rear retainer and case index marks and install retainer. Install and tighten retainer bolts to 23 foot-pounds (23 N•m) torque.
- (35) Install oil seal in rear retainer bore. Coat seal lip with petroleum jelly before installation.
- (36) Install washer and indicator switch. Tighten switch to 18 foot-pounds (24 N•m) torque.
- (37) Apply small quantity of Loctite 515, or equivalent sealant, to detent retainer bolt and install detent ball, spring and bolt (fig. 2D-10). Tighten bolt to 23 foot-pounds (31 N•m) torque.
- (38) Install drain plug and gasket. Tighten plug to 35 foot-pounds (47 N•m) torque.
- (39) Install oil seal in front case output shaft bore.
- (40) Install front and rear yokes. Be sure to install yoke, with collar on it, on front output shaft.
- (41) Install yoke seal washers and yoke nuts. Tighten nuts to 120 foot-pounds (163 N•m) torque.
- (42) Pour 6 pints (3 liters) of 10W-30 motor oil into transfer case through fill plug hole and install and tighten fill plug to 18 foot-pounds (24 N•m) torque.

SPECIFICATIONS

Specifications—Model 208 Transfer Case

Transfer Case Type	4-position, dual range, part-time 4-wheel drive unit with integral low range
Torque Transmittal Mode	Dual sprockets with interconnecting drive chain
Low Range Reduction Ratio and Mode	2.6:1 through annulus gear and planetary carrier assembly
Drive positions and shift controls	2H, 4H, 4L, Neutral — Ranges selected via floor-mounted shift lever. (4-wheel drive ranges are undifferentiated)
Case Configuration	Two-piece aluminum casting with removable rear retainer
Lubricant Capacity and Type	6 pints (3 liters) Jeep, Dextron II Automatic transmission fluid only.

90621

Torque Specifications

Service Set-To Torques should be used when assembling components. Service In-Use Recheck Torques should be used for checking a pre-tightened item.

	USA (ft-lbs)		Metric (N•m)	
	Service Set-To Torque	Service In-Use Recheck Torque	Service Set-To Torque	Service In-Use Recheck Torque
Detent Retainer Bolt	23	20-25	31	27-34
Drain and Fill Plugs	35	30-40	47	40-54
Front/Rear Yoke Nuts	120	90-130	163	122-176
Indicator Switch	18	15-20	24	20-34
Operating Lever Locknut	18	14-20	24	19-27
Rear Case-to-Front Case Bolts (All)	23	20-25	31	27-34
Rear Retainer Bolts	23	20-25	31	27-34

All torque values given in foot-pounds and newton-meters with dry fits unless otherwise specified.

90620

MODEL 219 QUADRA-TRAC TRANSFER CASE

	Page
Assembly	2D-34
Cleaning and Inspection	2D-28
Disassembly	2D-26
General	2D-22
Identification	2D-22
In-Vehicle Service	2D-25

	Page
Lubrication	2D-22
Power Flow	2D-22
Service Diagnosis	2D-24
Specifications	2D-37
Subassembly Overhaul	2D-30

GENERAL

The model 219 Quadra-Trac transfer case provides four-wheel high and low ranges, a neutral position and a four-wheel high-lock position for use when the vehicle is immobile due to excessive wheel spin.

Model 219 provides full-time, fully differentiated operation in 4H range only. The 4L and Lock ranges provide undifferentiated drive modes. In 4H range, differentiation is accomplished through a torque biasing viscous coupling and an open differential connected to the coupling. Two drive sprockets and an interconnecting drive chain are used to distribute input torque.

Drive range selection is by means of a floor mounted shift lever. A straight line shift pattern is used for all models equipped with the 219 (fig. 2D-40).

Four-Wheel High-Lock Position Indicator Lamp

An indicator lamp is mounted in the instrument panel to alert the driver whenever the vehicle is being operated in four-wheel high-lock range. The lamp is controlled by an indicator switch in the transfer case. The switch is a ball and plunger unit that is activated by the transfer case range sector when four-wheel high-lock range is selected. The indicator lamp is illuminated in the four-wheel high-lock position only.

IDENTIFICATION

An identification tag is attached to the rear half of the transfer case (fig. 2D-3). This tag provides the transfer case model number, low range reduction ratio, and assembly number. The information on this tag is necessary for servicing information. If the tag is removed or becomes dislodged during service operations, it should be reattached using an adhesive sealant such as Loctite 312, or equivalent.

LUBRICATION

The model 219 transfer case lubricant should be changed at the intervals specified in the Maintenance Schedule. When adding lubricant to or refilling the

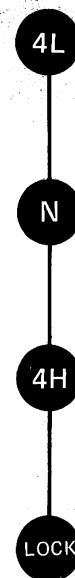

Fig. 2D-40 Model 219 Shift Pattern

transfer case after service, use AMC/Jeep Automatic Transmission Fluid or equivalent labeled Dexron II®. Do not use any type of anti-friction type additives or similar substance. Use the specified grade of motor oil only. Refer to the In-Vehicle Service section for lubricant change procedures and fill level. Model 219 lubricant capacity is 4 pints (2 liters).

POWER FLOW

Four-Wheel High (4H) Range

In all drive range positions, input torque is transmitted to the transfer case geartrain through the input gear (fig. 2D-41).

In four high range (4H), torque flows from the input gear to the planetary assembly and annulus gear which rotate as a unit. Torque is transferred to the mainshaft through the planetary carrier which is splined to the mainshaft (fig. 2D-41).

In 4H range, the clutch sleeve is not engaged with the mainshaft. Torque flows through the mainshaft to the differential pinions which are splined to the mainshaft.

Torque is then transmitted through the pinions to the gear teeth on the side gear and rear output shaft. Since the side gear is splined to the drive sprocket, torque is also transmitted to the front output shaft through the driven sprocket which is connected to the drive sprocket by the drive chain (fig. 2D-41).

Viscous Coupling and Differential Operation in 4H Range

The differential assembly consists of the side gear, rear output shaft and the viscous coupling and differential pinion gear assembly. The differential operates in the same fashion as an open-type axle differential. In straight-ahead driving, the differential and coupling rotate as a unit. On turns, the differential allows the front and rear axles to operate at their own speeds. This occurs because the pinions are then free to rotate around

the side gear and rear output shaft gear teeth at differing speeds.

The viscous coupling functions as a torque biasing slip limiting unit. It consists of an enclosed housing containing two sets of fixed clutch plates and a special silicone fluid. The differential pinion gears are located in the open center section of the coupling.

The coupling is connected to the front propeller shaft through the side gear and drive sprocket which operates the driven sprocket and front output shaft via the drive chain. The rear propeller shaft is connected to the coupling through the rear output shaft side gear teeth which are meshed with the differential pinions. In normal operation, the coupling is not active. Front/rear axle speed differences that produce drive line torque loads are dissipated by the differential. However, when extreme speed variations between axles occur, such as

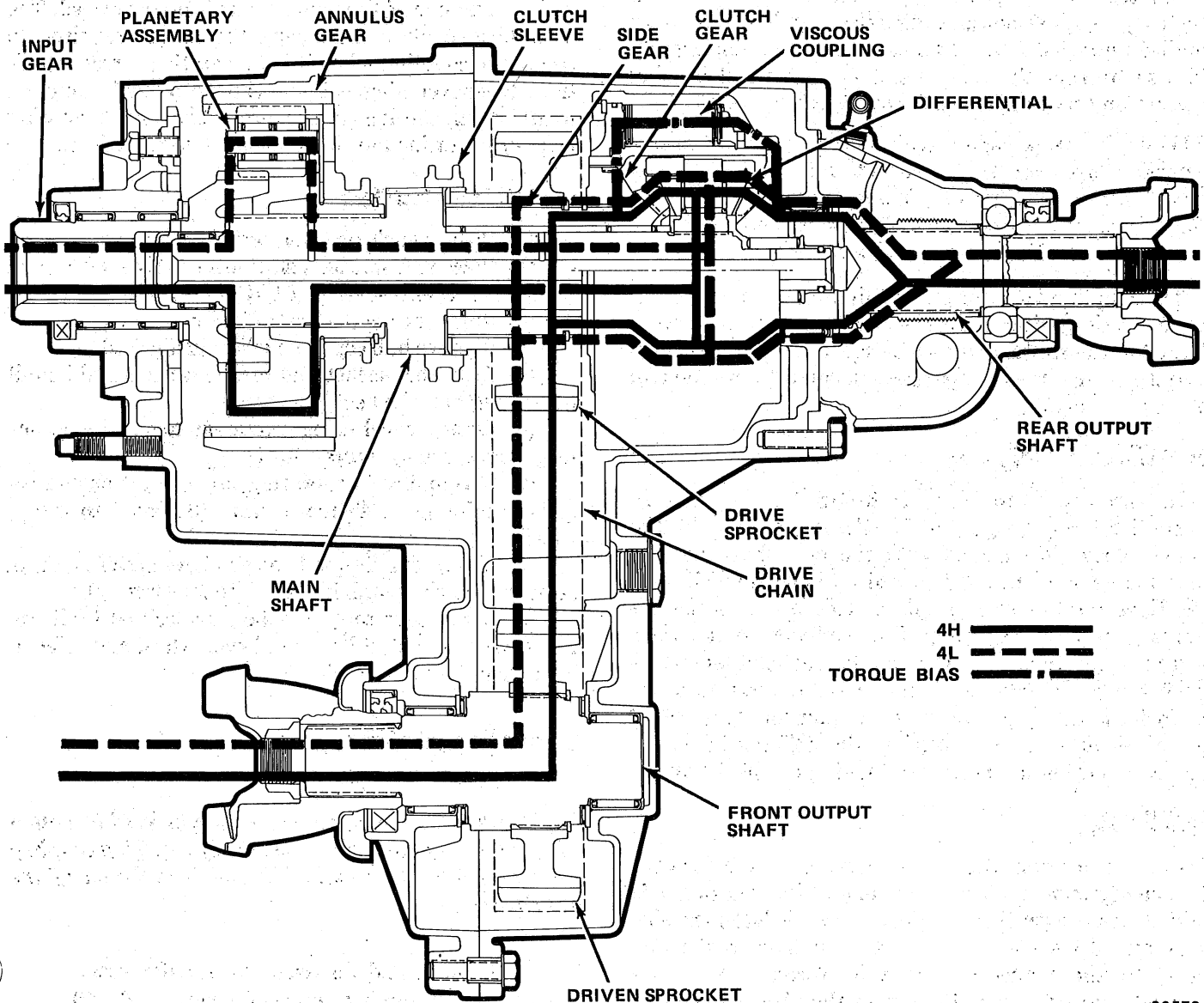

Fig. 2D-41 Power Flow—Model 219 Quadra-Trac Transfer Case

when one wheel or set of wheels spin on an ice covered surface, the coupling acts to transfer torque to the axle wheels having greater traction.

The special silicone fluid in the enclosed portion of the coupling is quite viscous and does not thin out when heated or subjected to high shear forces. In operation, when one axle overspeeds due to wheel slip, the input to the coupling causes the coupling rotational speed to increase also. However, as coupling speed increases, the fixed clutch plates in the coupling are forced to rotate (shear) through the silicone fluid at higher speeds also. As the fluid is forced between the plates, it is displaced and expands, creating shear friction and increased resistance to further increases in input speed. This resistance to rotating speed increases in direct proportion to the increase in input speed from the front or rear axle through the propeller shaft.

In situations where the coupling becomes operational, the coupling does not lock the axles together to produce undifferentiated four-wheel drive. The coupling merely limits (controls) the amount of slippage while delivering maximum torque to the axle having greater traction.

NOTE: *The coupling and pinion assembly is not a serviceable component. It is a sealed unit and is not refillable. If the coupling or pinions become damaged in some way, it must be replaced as an assembly only. Do not attempt to disassemble the unit.*

The coupling does not provide limited slip operation in 4L or Lock positions. In these ranges the coupling is locked to the shafts and torque flow bypasses the differential. Transfer case operation is undifferentiated in these drive modes.

Four-Wheel Low (4L) Range

In 4L range, the torque path through the transfer case is similar to 4H range (fig. 2D-41). However, in 4L the clutch sleeve is engaged with the mainshaft and the annulus gear is shifted forward into engagement with the fixed (stationary) lockplate. This prevents the annulus gear from rotating. The planetary pinions are forced to rotate around the annulus internal teeth producing a gear reduction ratio of 2.61:1. Because the mainshaft, side gear and sprocket and coupling are all locked together in 4L position, the differential is bypassed resulting in undifferentiated four-wheel drive.

Lock Position

In Lock position, the clutch sleeve is moved forward into engagement with the mainshaft. Since the sleeve is still engaged with the side gear clutch, it locks the side gear and drive sprocket, which is splined to the side gear, to the mainshaft as well. Torque now flows through the side gear directly to the viscous coupling housing through the clutch gear which is splined to the side gear. Because the rear output shaft is also splined to

the coupling housing, the differential is bypassed resulting in an undifferentiated four-wheel drive-lock mode. This range should be used only when the vehicle is immobile due to excessive wheel spin.

SERVICE DIAGNOSIS

Before attempting to repair a suspected transfer case malfunction, check all other drive line components beforehand. The actual cause of a problem may be related to such items as the front hubs, axles, propeller shafts, wheels and tires, transmission, or clutch instead. If all other drive line components are in good condition and operating properly, refer to the service diagnosis charts for further information.

Torque Bias Check—Model 219

A method for checking viscous coupling operation, both in and out of the vehicle, has been developed. The procedure involves measuring the torque required to rotate the coupling when it is in a static (at rest) condition. Whenever diagnosis indicates a possible coupling malfunction, check coupling torque bias (static rotating torque) as outlined in the following two procedures.

In-Vehicle Torque Bias Check

- (1) Place vehicle on level surface. Stop engine.
- (2) Place transmission shift lever in NEUTRAL and transfer case shift lever in 4-HIGH position.
- (3) Raise one front wheel off floor.
- (4) Remove hub cap from wheel just raised.
- (5) Assemble socket and torque wrench and install on any lug nut of wheel just raised.
- (6) Rotate wheel using torque wrench and measure torque required to rotate wheel.
- (7) If coupling is operating properly, it should require minimum of 45 foot-pounds (61 N•m) to rotate wheel.
- (8) If rotating torque is at or above specified limit, remove wrench, install hub cap and lower wheel.
- (9) If rotating torque is below specified limit, remove wrench, install hub cap, lower wheel and refer to On-Bench Torque Bias Check.

On-Bench Torque Bias Check

NOTE: *The following procedure can be used as both a diagnostic procedure and a means of verifying coupling operation prior to reassembly and installation of the transfer case.*

- (1) Remove and disassemble transfer case.
- (2) Install clutch gear on side gear (fig. 2D-42).
- (3) Install assembled clutch gear and side gear in viscous coupling.

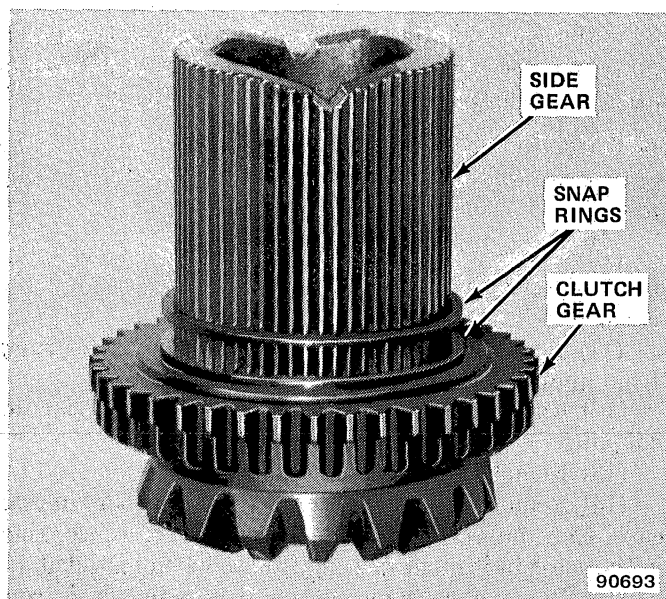

Fig. 2D-42 Side Gear Components

(4) Mount assembled coupling and gears in vise. Place wood blocks between vise jaws and side gear and clamp side gear firmly (fig. 2D-43).

CAUTION: Wood blocks must be placed between the vise jaws and side gear to avoid damaging the gear.

(5) Check engagement of clutch gear in viscous coupling. Be sure gear is fully engaged in coupling before proceeding. If necessary, loosen vise and reposition wood blocks so they support gear in coupling.

(6) Install rear output shaft in viscous coupling (fig. 2D-43).

(7) Install yoke on rear output shaft and install yoke retaining nut.

(8) Assemble and install socket and torque wrench on yoke retaining nut (fig. 2D-43).

(9) Rotate rear output shaft using torque wrench and measure torque required to rotate shaft in coupling.

(10) Torque required to rotate shaft in coupling should be minimum of 25 foot-pounds (34 N•m) torque.

(11) If rotating torque is less than specified, coupling has malfunctioned. If torque is at or above specified limit, coupling is in good condition.

IN-VEHICLE SERVICE

Changing Lubricant

- (1) Raise vehicle.
- (2) Position drain pan under transfer case.
- (3) Remove fill and drain plugs, and drain lubricant.
- (4) Install drain plug. Tighten plug to 35 foot-pounds (47 N•m) torque.
- (5) Fill transfer case to bottom edge of fill plug hole with AMC/Jeep Automatic Transmission Fluid or equivalent labeled Dexron®.

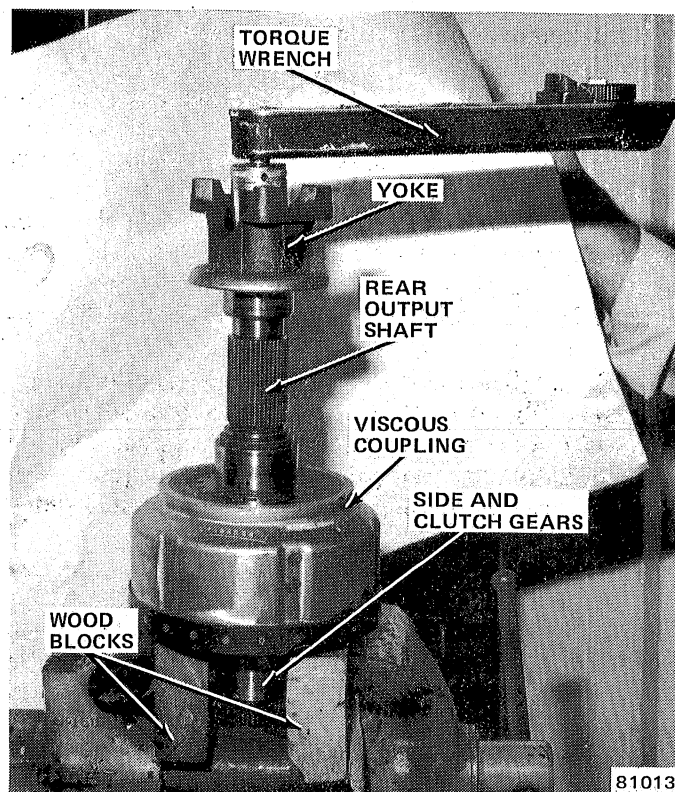

Fig. 2D-43 Torque Bias Check—On-Bench

(6) Install and tighten fill plug to 35 foot-pounds (47 N•m) torque.

(7) Remove drain pan and lower vehicle.

Speedometer Gear, Rear Bearing, Rear Seal, and Shaft Yoke Replacement

NOTE: The front and rear yokes, seals, rear retainer and bearing and speedometer gear can all be serviced in the vehicle. The following combined procedure outlines replacement of these components.

Replacement

- (1) Raise vehicle.
- (2) Position drain pan under transfer case.
- (3) Remove fill and drain plugs. Drain oil from transfer case.
- (4) Mark propeller shaft and transfer case yoke for assembly reference.
- (5) Disconnect propeller shaft. Secure shaft to underside of vehicle.
- (6) Remove and discard transfer case yoke nut and seal washer. Use Tool J-8614-01 to hold yoke while removing nut.
- (7) Remove yoke. Use Tools J-8614-01, -02, -03 to remove yoke, if necessary.
- (8) Remove speedometer cable from retainer.
- (9) Mark rear retainer for assembly reference and remove retainer.

(10) Remove differential shims and speedometer driven gear.

(11) Remove rear output bearing snap ring and remove bearing from retainer.

(12) Remove rear seal from retainer using punch or screwdriver.

(13) Install bearing in retainer. Be sure shielded side of bearing is facing case interior. Install bearing snap ring.

(14) Install rear yoke seal using Tool J-29162 (fig. 2D-26).

(15) Install speedometer gear and differential shim.

(16) Apply Loctite 515, or equivalent sealant, to mating surface of rear retainer and install retainer. Tighten retainer bolts to 23 foot-pounds (31 N•m) torque.

(17) Install yoke, seal washer and yoke nut. Tighten nut to 120 foot-pounds (163 N•m) torque.

(18) Install speedometer cable.

(19) Connect propeller shaft.

(20) Install drain plug and fill transfer case to bottom edge of fill plug hole with AMC/Jeep Automatic Transmission Fluid or equivalent labeled Dexron II® only.

(21) Install fill plug. Tighten fill and drain plugs to 18 foot-pounds (24 N•m) torque.

(22) Remove drain pan and lower vehicle.

DISASSEMBLY

(1) Remove fill and drain plugs. Drain lubricant from transfer case.

(2) Remove front and rear output shaft yokes (fig. 2D-44). Discard yoke seal washers and yoke nuts.

(3) Mark rear retainer and rear case for assembly alignment reference.

(4) Remove rear retainer attaching bolts and remove retainer. Use plastic mallet to loosen retainer if necessary. Do not pry retainer off rear case.

(5) Remove differential shim(s) and speedometer drive gear from rear output shaft (fig. 2D-40). Tag shim(s) for assembly reference.

NOTE: *The speedometer gear fits on the shaft one way only. The long end should face the case. Note gear position for assembly reference.*

(6) Remove rear output bearing snap ring and remove bearing from retainer using plastic mallet.

NOTE: *The rear output bearing has one side shielded. Note bearing position for assembly reference.*

(7) Remove rear output shaft seal from rear retainer using screwdriver or punch.

(8) Position front case assembly on wood blocks (fig. 2D-41).

NOTE: *The wood blocks will support the case assembly in a more solid manner if "V" notches are cut in the blocks beforehand.*

(9) Remove bolts attaching rear case to front case and remove rear case. Insert screwdrivers in notches at case ends to pry rear case off front case (fig. 2D-42).

NOTE: *The two case-end bolts have flat washers and alignment dowels. Note bolt, dowel and washer location for assembly reference (fig. 2D-44).*

(10) Remove rear output shaft and viscous coupling as assembly (fig. 2D-48). Tap shaft with plastic mallet to remove it, if necessary.

(11) Remove O-ring seal and pilot roller bearings from mainshaft (fig. 2D-48).

(12) Remove rear output shaft from viscous coupling.

(13) Remove shift rail spring from rail.

(14) Remove plastic oil pump from shaft bore in rear case. Note pump position for assembly reference. End with recess in it must face shaft bore when installed.

(15) Remove rear output shaft bearing seal from case. Use screwdriver to pry seal out of seal bore.

(16) Remove front output shaft thrust bearing assembly (fig. 2D-49). Remove thick washer, bearing and thin washer. Tag assembly for installation reference.

(17) Remove driven sprocket retaining snap ring (fig. 2D-50).

(18) Remove drive sprocket, drive chain, driven sprocket, side gear clutch and clutch gear as assembly (fig. 2D-51). Place assembly on workbench and mark components for assembly installation reference, especially sprockets.

(19) Remove needle bearings and bearing spacers from mainshaft or side gear bore. Total of 82 needle bearings and two spacers are used.

(20) Remove side gear/clutch gear assembly from drive sprocket (fig. 2D-47). Remove two snap rings and remove clutch gear from side gear. Note position of snap rings and gears for assembly reference (fig. 2D-53).

(21) Remove side gear clutch (fig. 2D-54) and mainshaft thrust washer.

(22) Remove front output shaft and shaft thrust bearing assembly (fig. 2D-55). Note installation sequence of thrust bearing assembly. Correct sequence is thin race-bearing-thick race.

(23) Remove front output shaft seal from front case using screwdriver or punch.

(24) Remove shift rail spring from shift rail if not already removed. Tag spring for assembly reference.

(25) Remove clutch sleeve, mode fork and mode fork spring as assembly (fig. 2D-56). Note position of components for assembly reference. Disassemble components for cleaning and inspection.

(26) Remove mainshaft thrust washer and remove mainshaft (fig. 2D-57). Grasp shaft and pull straight up to remove.

(27) Move range operating lever downward to last detent position.

(28) Disengage range fork lug from range sector slot (fig. 2D-21).

Service Diagnosis

Condition	Possible Cause	Correction
FRONT OR REAR OF VEHICLE TENDS TO PULL OR WANDER OCCASIONALLY WHEN DRIVING IN STRAIGHT DIRECTION	(1) Incorrect or unequal tire pressures (2) Mismatched tires	(1) Adjust tire pressures to within ½ - 1 pound on all four wheels. (2) Install tires of equal size and type on all four wheels.
TRANSFER CASE DIFFICULT TO SHIFT OR WILL NOT SHIFT INTO DESIRED RANGE	(1) Vehicle speed too great to permit shifting. (2) External shift linkage binding, bent, loose. (3) Internal components worn, binding or damaged.	(1) Slow vehicle to 2-3 mph (3-4 km/h) or stop vehicle and shift into desired range (2) Repair linkage as necessary. (3) Disassemble unit and replace worn or damaged components.
NOISY IN — OR JUMPS OUT OF 4L RANGE	(1) Transfer case not completely engaged in 4L. (2) Shift linkage binding bent, loose. (3) Range fork, shift rail, annulus gear, or clutch sleeve lockplate, worn or damaged.	(1) Stop vehicle, shift transfer case to neutral; then shift back into 4L. (2) Repair linkage as necessary. (3) Disassemble unit and replace worn or damaged components.
NOISY IN ALL DRIVE MODES	(1) Insufficient or incorrect lubricant.	(1) Drain and refill with Jeep, Dextron Automatic transmission fluid only. Check for leaks if fluid level was low and repair as necessary. Note: If unit is still noisy after drain and refill, disassembly and inspection may be necessary to locate source of noise.
SEVERE LOW SPEED SHUDDER NOTED DURING ROAD TEST ON 219 TRANSFER CASE	(1) Indicates low or loss of viscous silicone fluid.	(1) Check transfer case lubricant for burnt fluid containing viscous silicone fluid. (2) If verified remove transfer case and disassemble. Check viscous coupling for case cracks, blown seal. (3) Replace as necessary. (4) Inspect front and rear axle for correct ratio.
LUBRICANT LEAKS FROM OUTPUT SHAFT SEALS OR FROM VENT	(1) Transfer case overfilled. (2) Vent closed or restricted. (3) Shaft seals damaged or installed incorrectly.	(1) Drain to correct level. (2) Clean or replace vent. (3) Replace seals. Be sure seal lip faces interior of case when installed. Also check yoke seal surfaces for nicks, scratches. Use crocus cloth to remove minor surface irregularities.

- (29) Remove annulus gear retaining snap ring and thrust washer (fig. 2D-58).
- (30) Remove annulus gear and range fork as assembly (fig. 2D-59). Separate components for cleaning and inspection.
- (31) Remove planetary thrust washer from planetary assembly hub (fig. 2D-60).
- (32) Remove planetary assembly (fig. 2D-61). Grasp planetary hub and lift assembly upward to remove it.
- (33) Remove mainshaft thrust bearing from input gear (fig. 2D-61).
- (34) Remove input gear and remove input gear thrust bearing and race (fig. 2D-62).
- (35) Remove range sector detent ball and spring retaining bolt and remove detent ball and spring (fig. 2D-10).

- (36) Remove range sector and operating lever attaching nut and lockwasher and remove lever.
- (37) Remove range sector.
- (38) Remove range sector shaft O-ring and retainer (fig. 2D-44).
- (39) Remove input gear oil seal from front case using screwdriver or punch.

CLEANING AND INSPECTION

Wash all parts thoroughly in clean solvent. Be sure all old lubricant, metallic particles, dirt, or foreign material are removed from the surfaces of every part. Apply compressed air to each oil feed port and channel in each case half to remove any obstructions or cleaning solvent residue.

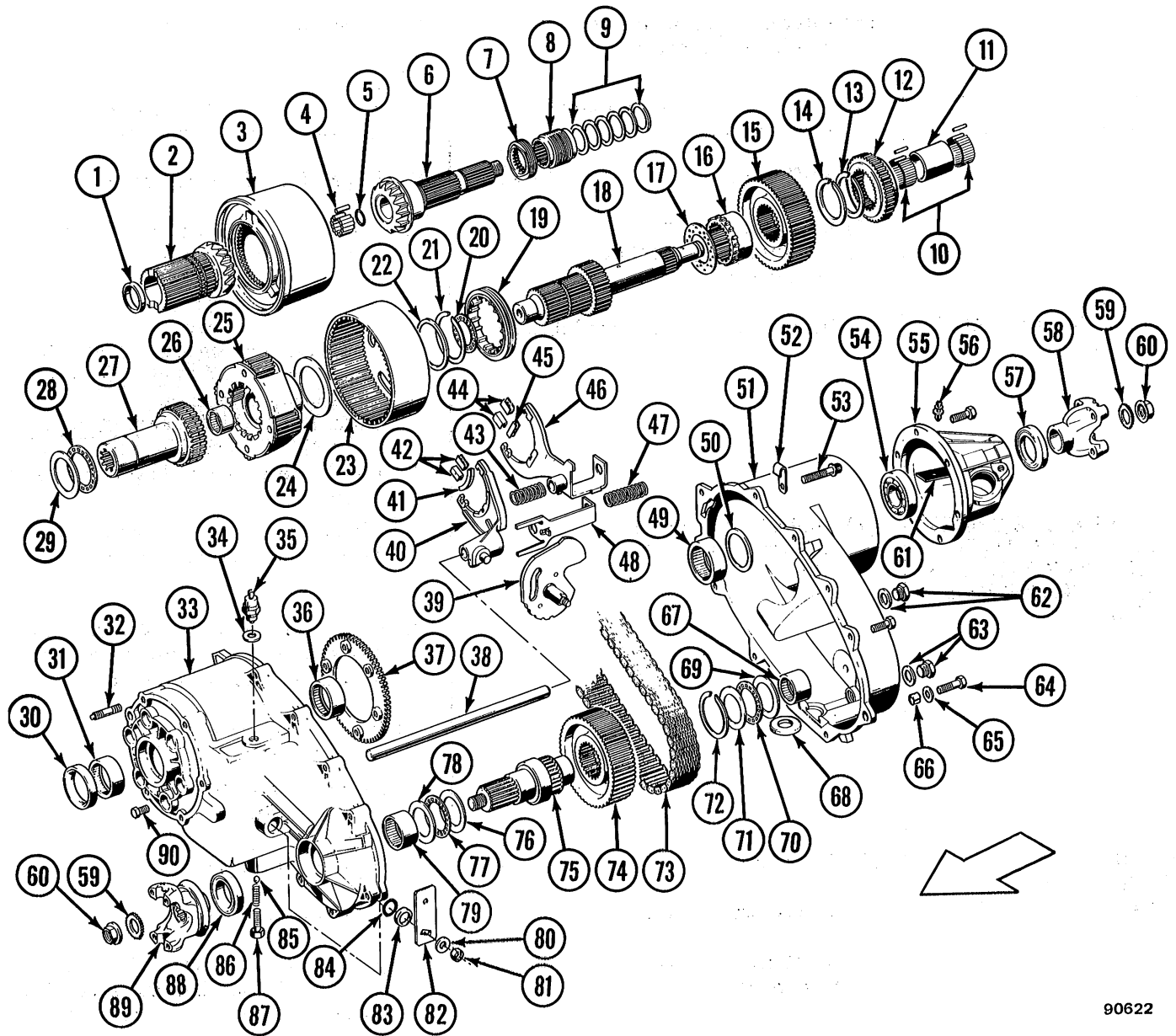

Fig. 2D-44 Model 219 Quadra-Trac Transfer Case

1. MAINSHAFT REAR BEARING SPACER - SHORT (2)
2. SIDE GEAR
3. VISCOUS COUPLING AND DIFFERENTIAL ASSEMBLY
4. MAINSHAFT REAR PILOT ROLLER BEARINGS (15)
5. MAINSHAFT O-RING
6. REAR OUTPUT SHAFT
7. OIL PUMP
8. SPEEDOMETER GEAR
9. DIFFERENTIAL END PLAY SHIMS (SELECTIVE)
10. MAINSHAFT NEEDLE BEARINGS (82)
11. MAINSHAFT REAR BEARING SPACER
12. CLUTCH GEAR
13. CLUTCH GEAR LOCATING RING
14. DRIVE SPROCKET LOCATING RING
15. DRIVE SPROCKET
16. SIDE GEAR CLUTCH
17. MAINSHAFT THRUST WASHER
18. MAINSHAFT
19. CLUTCH SLEEVE
20. MAINSHAFT THRUST BEARING
21. ANNULUS GEAR RETAINING RING
22. ANNULUS GEAR THRUST WASHER
23. ANNULUS GEAR
24. PLANETARY THRUST WASHER
25. PLANETARY ASSEMBLY
26. MAINSHAFT FRONT PILOT BEARING
27. INPUT GEAR
28. INPUT GEAR THRUST BEARING
29. INPUT GEAR THRUST BEARING RACE
30. INPUT GEAR OIL SEAL
31. INPUT GEAR FRONT BEARING
32. FRONT CASE MOUNTING STUD (6)
33. FRONT CASE
34. LOCK MODE INDICATOR SWITCH GASKET
35. LOCK MODE INDICATOR SWITCH
36. INPUT GEAR REAR BEARING
37. LOW RANGE LOCKPLATE
38. SHIFT RAIL
39. RANGE SECTOR
40. RANGE FORK
41. RANGE FORK INSERT
42. RANGE FORK PADS
43. MODE FORK SPRING
44. MODE FORK PADS
45. MODE FORK INSERT
46. MODE FORK
47. SHIFT RAIL SPRING
48. MODE FORK BRACKET
49. REAR OUTPUT SHAFT BEARING
50. REAR OUTPUT SHAFT BEARING SEAL
51. REAR CASE
52. WIRING CLIP
53. SPLINE BOLT
54. REAR OUTPUT BEARING
55. REAR RETAINER
56. VENT
57. OUTPUT SHAFT OIL SEAL
58. REAR YOKE
59. YOKE SEAL WASHER
60. YOKE LOCKNUT
61. VENT CHAMBER SEAL
62. FILL PLUG AND GASKET
63. DRAIN PLUG AND GASKET
64. REAR CASE BOLT
65. WASHER (2)
66. CASE ALIGNMENT DOWEL
67. FRONT OUTPUT SHAFT REAR BEARING
68. MAGNET
69. FRONT OUTPUT SHAFT REAR THRUST BEARING RACE (THICK)
70. FRONT OUTPUT SHAFT REAR THRUST BEARING
71. FRONT OUTPUT SHAFT REAR THRUST BEARING RACE (THIN)
72. DRIVEN SPROCKET RETAINING SNAP RING
73. DRIVE CHAIN
74. DRIVEN SPROCKET
75. FRONT OUTPUT SHAFT
76. FRONT OUTPUT SHAFT FRONT THRUST BEARING RACE (THIN)
77. FRONT OUTPUT SHAFT FRONT THRUST BEARING
78. FRONT OUTPUT SHAFT FRONT THRUST BEARING RACE (THICK)
79. FRONT OUTPUT SHAFT FRONT BEARING
80. WASHER
81. LOCKNUT
82. OPERATING LEVER
83. RANGE SECTOR SHAFT SEAL RETAINER
84. RANGE SECTOR SHAFT SEAL
85. DETENT BALL
86. DETENT SPRING
87. DETENT RETAINING BOLT
88. FRONT OUTPUT SHAFT SEAL
89. FRONT YOKE
90. LOCKPLATE BOLTS

90622

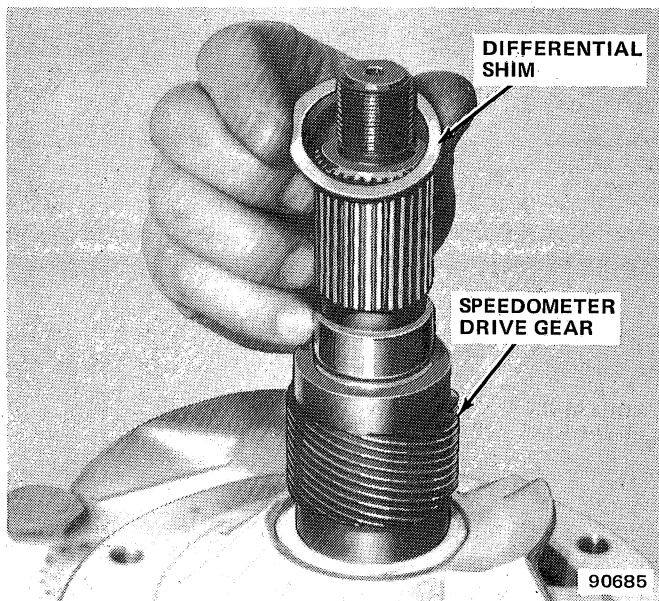

Fig. 2D-45 Differential Shim, Speedometer Gear and Oil Pump

Inspect all gear teeth for signs of excessive wear or damage and check all gear splines for burrs, nicks, wear or damage. Remove minor nicks or scratches with an oilstone. Replace any part exhibiting excessive wear or damage.

Inspect all snap rings and thrust washers for evidence of excessive wear, distortion, or damage. Replace any of these parts if they exhibit these conditions.

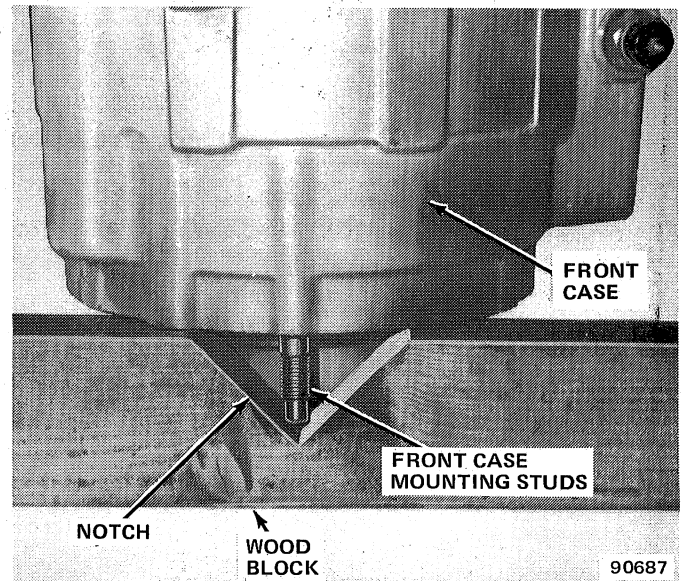

Fig. 2D-46 Mounting Transfer Case on Wood Blocks

Inspect the two case halves for cracks, porosity, damaged mating surfaces, stripped bolt threads, or distortion. Replace any part that exhibits these conditions.

Inspect the low range lockplate in the front case. If the lockplate teeth or the plate hub is cracked, broken, chipped, or excessively worn, replace the lockplate and the lockplate attaching bolts. Refer to the Low Range Lockplate Replacement procedure in the Subassembly Overhaul section.

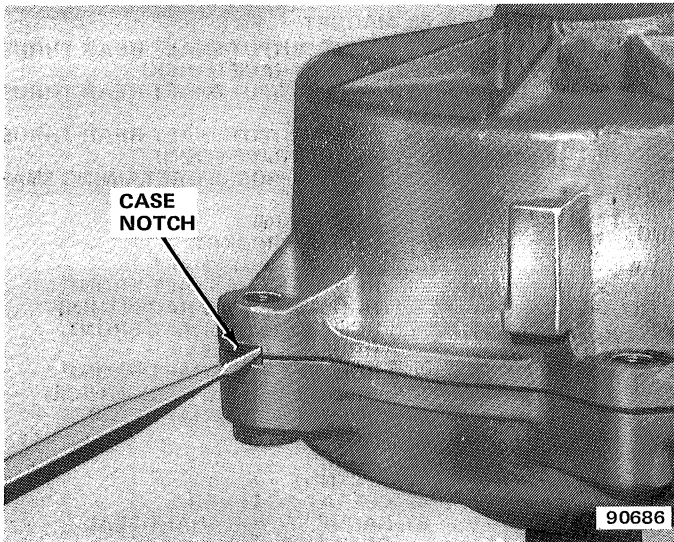

Fig. 2D-47 Rear Case Removal

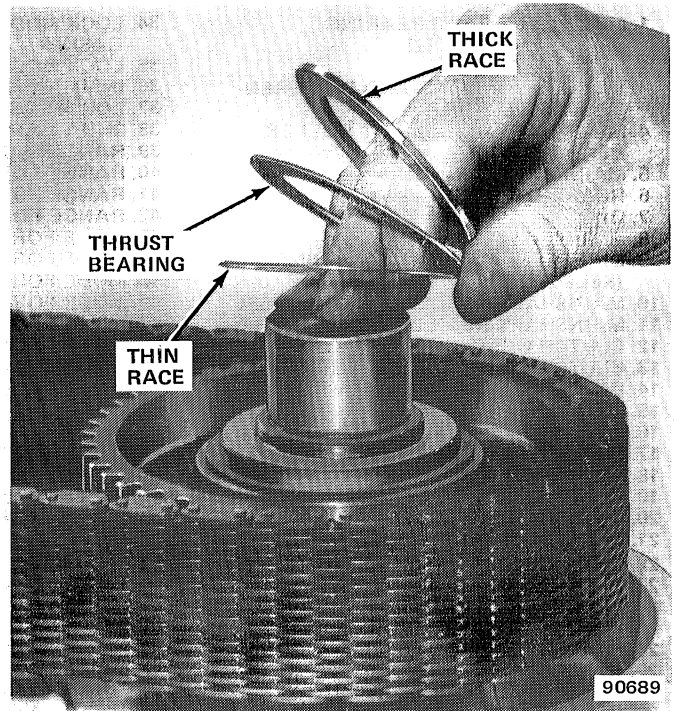

Fig. 2D-49 Front Output Shaft Rear Thrust Bearing Assembly Removal/Installation

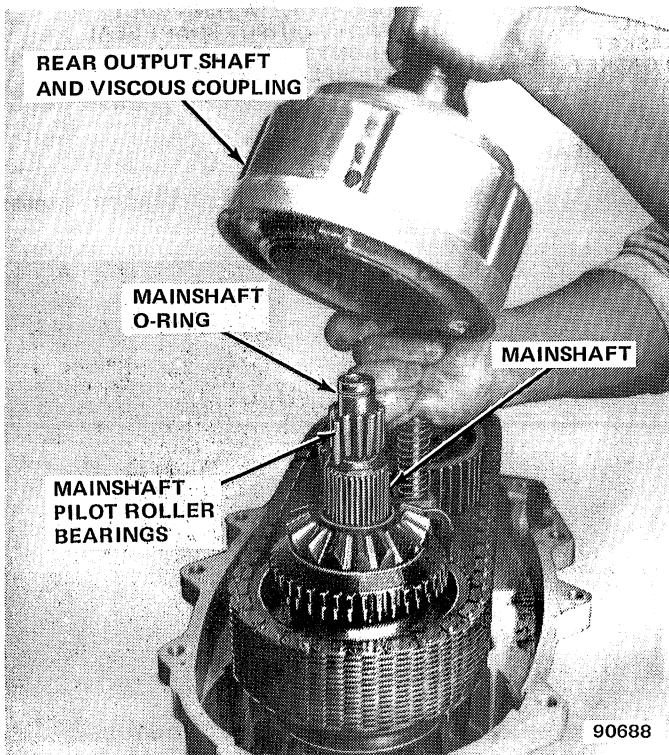

Fig. 2D-48 Viscous Coupling and Rear Output Shaft Removal/Installation

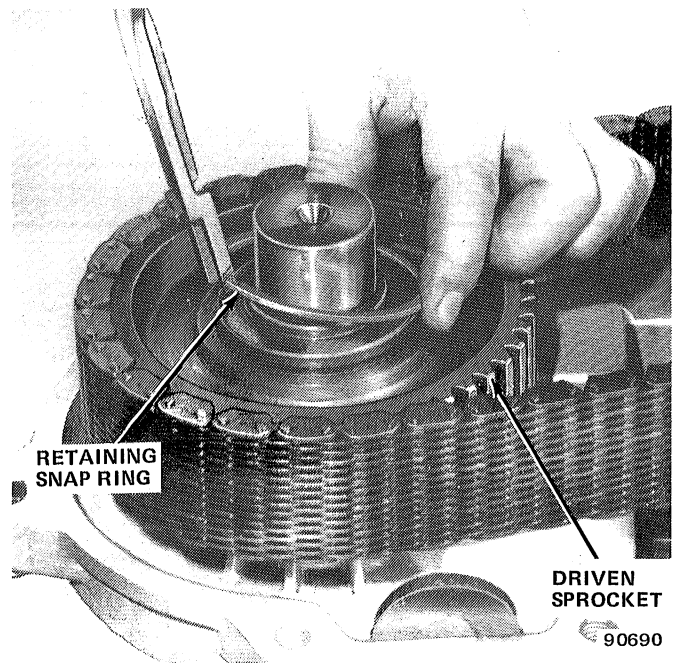

Fig. 2D-50 Driven Sprocket Retaining Snap Ring Removal/Installation

Inspect the condition of all needle, roller, ball and thrust bearings in the front and rear case halves, and the input gear. Also check the condition of the bearing bores in both cases and in the input gear, rear output shaft, side gear, and rear retainer. Replace any part that exhibits signs of excessive wear or damage. If the case or input gear bearings require replacement, refer to Bearing Replacement in the Subassembly Overhaul section.

Inspect the coupling and pinion gears. If the coupling is leaking fluid or the gears are worn or damaged in any

way, replace the coupling as an assembly only. Do not attempt to service the unit.

SUBASSEMBLY OVERHAUL

Lockplate Replacement

- (1) Remove and discard lockplate attaching bolts.

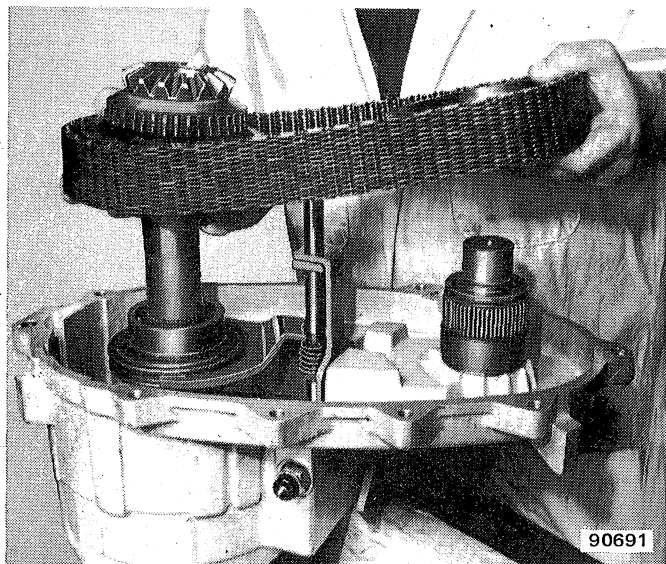

90691

Fig. 2D-51 Sprocket and Chain Removal—Installation

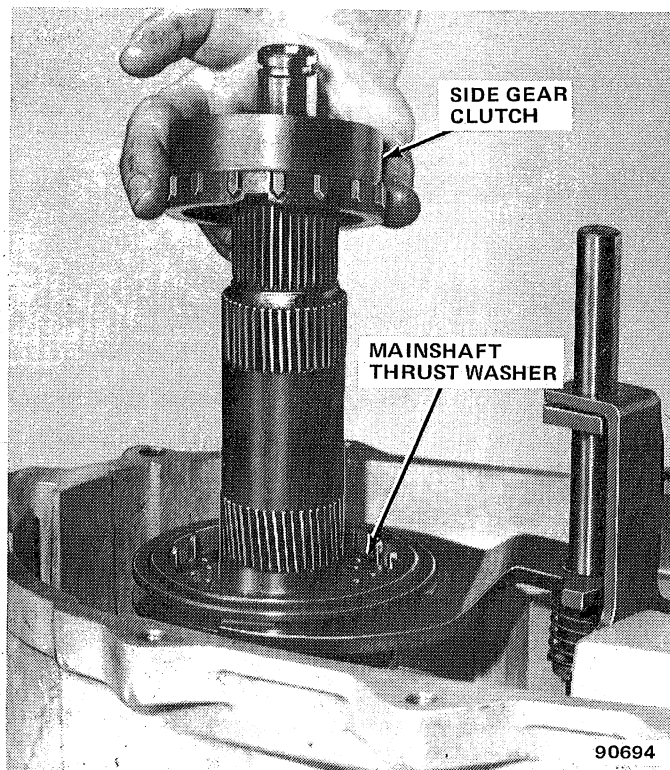

90694

Fig. 2D-54 Side Gear Clutch Removal/Installation

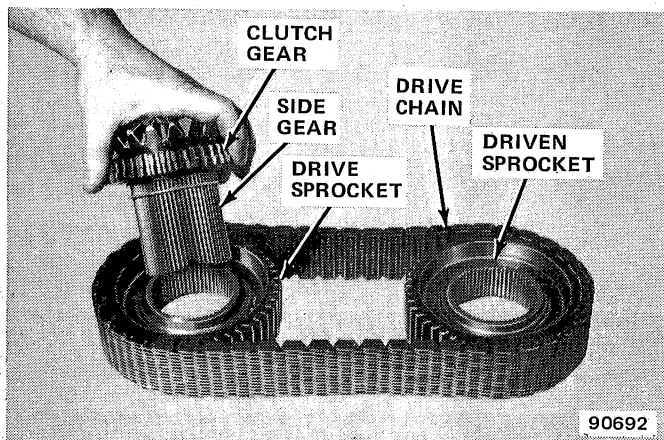

90692

Fig. 2D-52 Side Gear, Clutch Gear, Sprockets and Chain Assembly

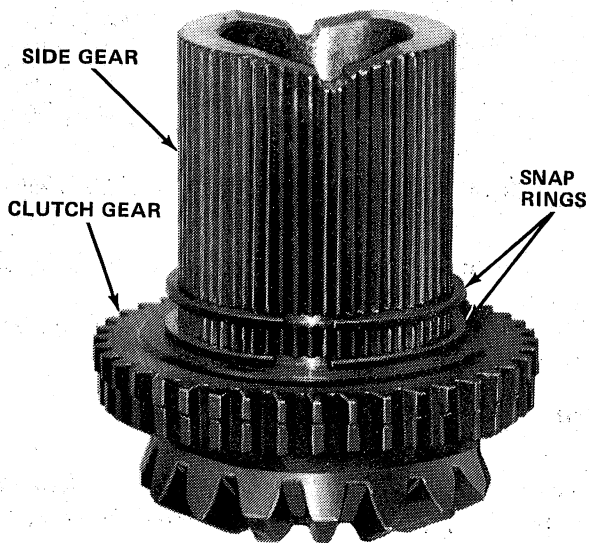

90643

Fig. 2D-53 Side Gear Components

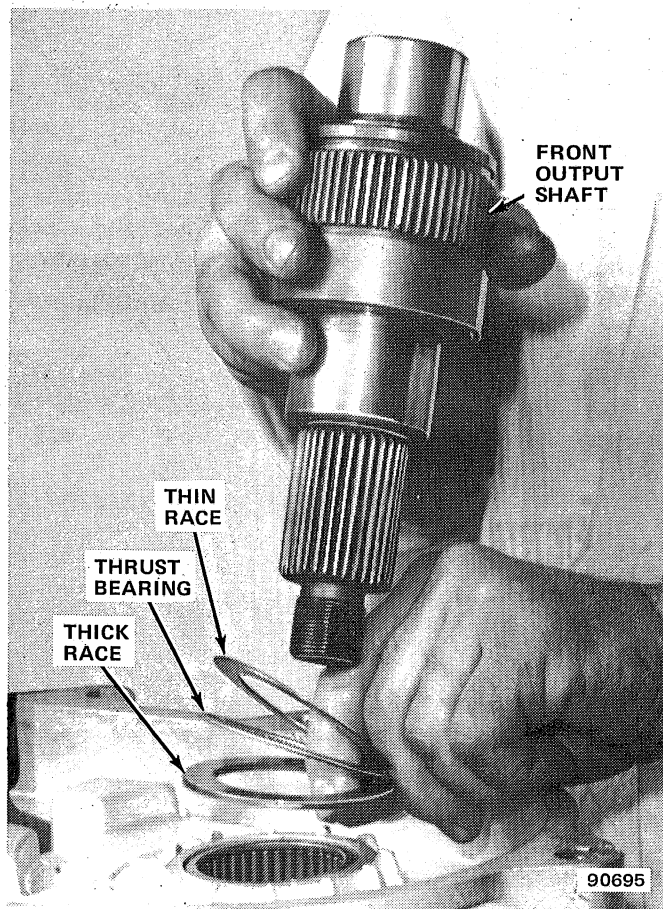

90695

Fig. 2D-55 Front Output Shaft and Shaft Front Thrust Bearing Removal/Installation

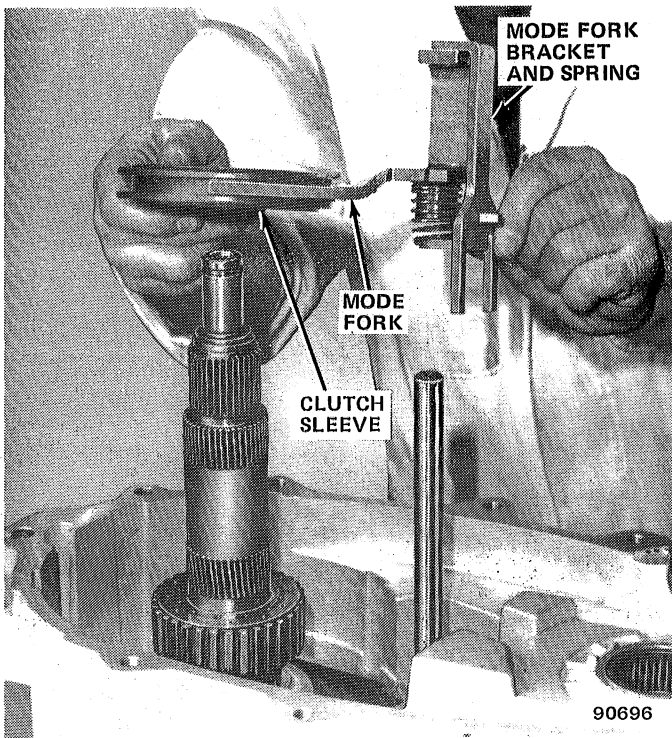

Fig. 2D-56 Clutch Sleeve and Mode Fork Removal/Installation

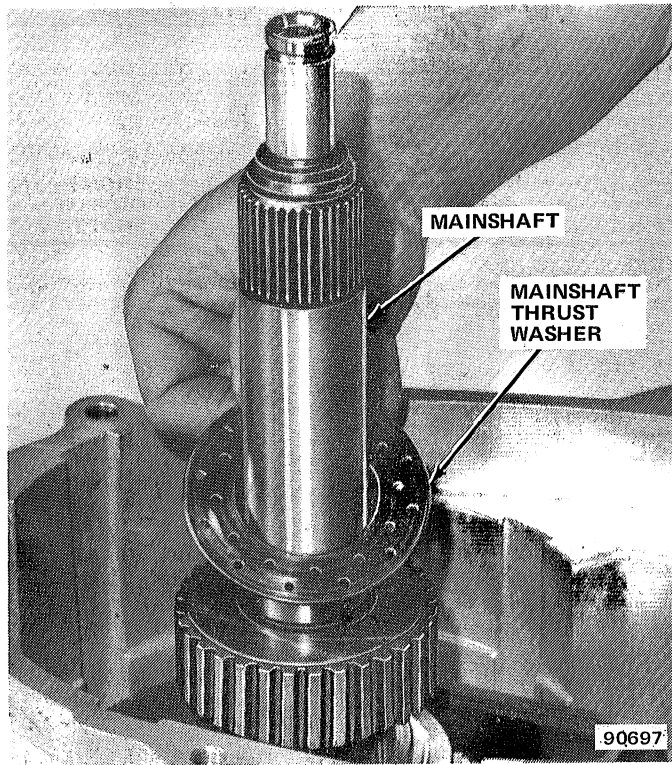

Fig. 2D-57 Mainshaft and Thrust Washer

- (2) Remove lockplate from case.
- (3) Coat case and lockplate surfaces around bolt holes with Loctite 515, or equivalent sealant.
- (4) Position new lockplate in case and align bolt holes in lockplate and case.

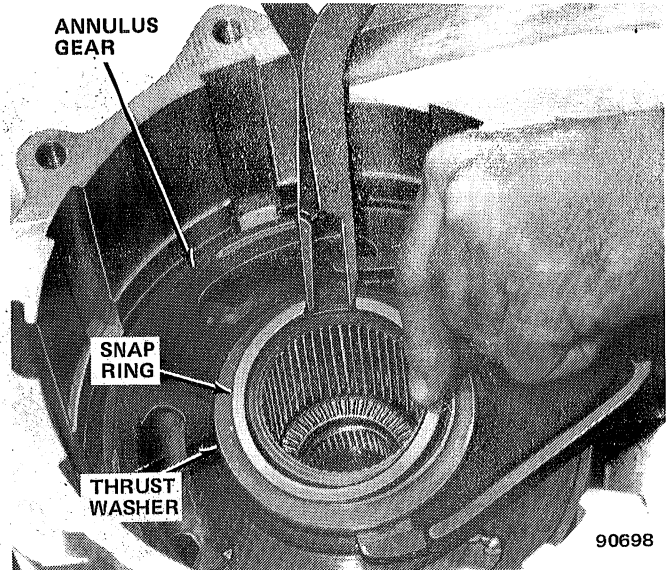

Fig. 2D-58 Annulus Gear Snap Ring and Thrust Washer Removal/Installation

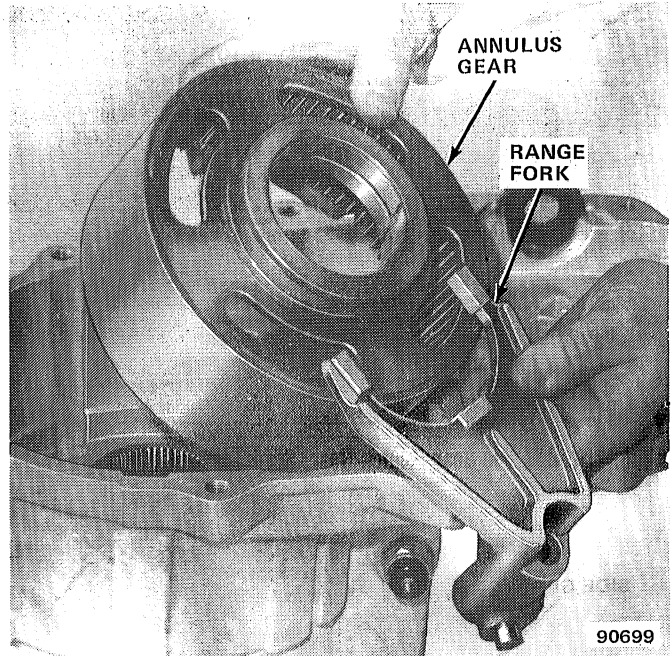

Fig. 2D-59 Annulus Gear and Range Fork Removal/Installation

- (5) Coat new lockplate attaching bolts with Loctite 271, or equivalent adhesive sealant.
- (6) Install and tighten lockplate attaching bolts to 30 foot-pounds (41 N•m) torque.

Bearing and Bushing Replacement

CAUTION: All of the bearings used in the transfer case must be correctly positioned to avoid covering the bearing oil feed holes. After replacing any bearing, check the bearing position to be sure the feed hole is not covered by the bearing.

Rear Output Shaft Bearing

(1) Remove bearing using Driver Handle J-8092 and Remover J-29165. Refer to figure 2D-27 for similar tool setup.

(2) Install bearing using Driver Handle J-8092 and Installer J-29166.

(3) Remove bearing installer tools and check bearing position to be sure the bearing oil feed hole is not covered.

Front Output Shaft Front Bearing

(1) Remove bearing using Driver Handle J-8092 and

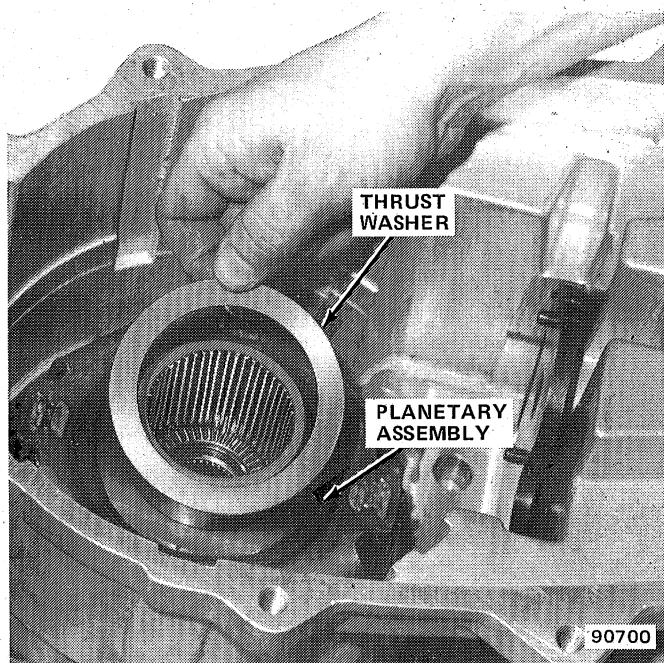

Fig. 2D-60 Planetary Thrust Washer Removal/Installation

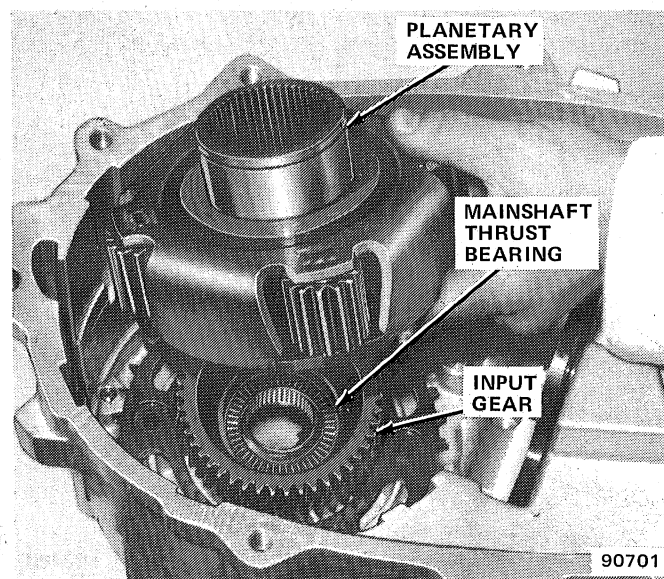

Fig. 2D-61 Planetary Assembly Removal/Installation

Remover J-29168 (fig. 2D-27).

(2) Install new bearing using Driver Handle J-8092 and Installer J-29167 (fig. 2D-28).

(3) Remove installer tools and check bearing position to be sure oil feed hole is not covered.

Front Output Shaft Rear Bearing

(1) Remove bearing using Remover J-26941 and Slide Hammer J-2619-01 (fig. 2D-29).

(2) Install new bearing using Driver Handle J-8092 and Installer J-29163 (fig. 2D-30).

(3) Remove installer tools and check bearing position to be sure oil feed hole is not covered. Also be sure bearing is seated flush with edge of bore in case to allow room for thrust bearing assembly.

Input Gear Front/Rear Bearings

(1) Remove both bearings simultaneously using Driver Handle J-8092 and Remover J-29170 (fig. 2D-31).

(2) Install new bearings one at a time. Install rear bearing first; then install front bearing. Use Driver Handle J-8092 and Installer J-29169 (fig. 2D-32).

(3) Remove installer tools and check bearing position to be sure oil feed holes are not covered. Also be sure bearings are flush with case bore surfaces.

Mainshaft Front Pilot Bearing

(1) If bearing cannot be removed by hand, remove it using Slide Hammer J-2619-01 and Remover J-29369-1 or similar internal type blind hole bearing puller (fig. 2D-33).

(2) If necessary, install new bearing using Driver Handle J-8092 and Installer J-29174. Be sure bearing is flush with bore (fig. 2D-34).

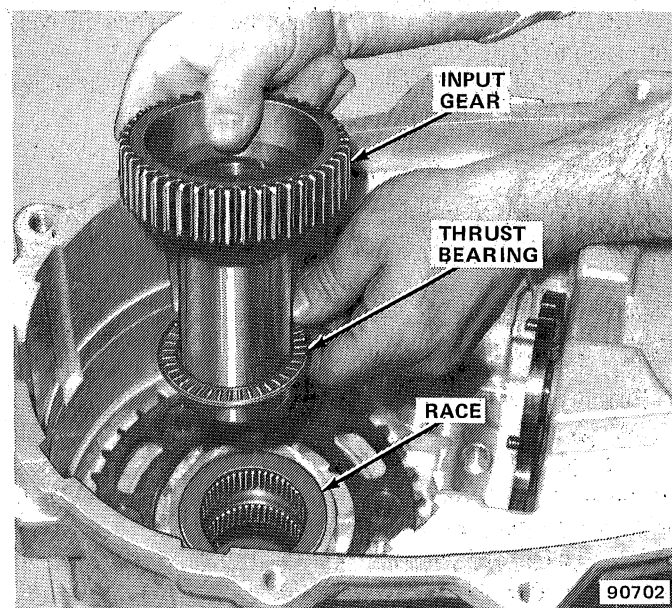

Fig. 2D-62 Input Gear and Thrust Bearing Removal/Installation

(3) If bearing was seated using installer tools, check bearing position to be sure oil feed hole is not covered. Also be sure bearing is seated flush with edge of bearing bore.

Rear Output Bearing and Seal

(1) Remove snap ring and remove bearing using rawhide mallet or brass punch.

(2) Install new bearing using Tools J-8092 and J-7818 (fig. 2D-25).

CAUTION: *Be sure the shielded side of the bearing faces the interior of the transfer case after installing it.*

(3) Install bearing snap ring.

(4) Install seal using Tool J-29162 (fig. 2D-26).

Annulus Gear Bushing Replacement

(1) Remove bushing using Driver Handle J-8092 and Remover—Installer Tool J-29185 (fig. 2D-35).

(2) Install new bushing using Tools J-8092 and J-29185 (fig. 2D-36).

(3) Remove any chips generated by bushing removal/installation.

ASSEMBLY

NOTE: *During assembly, prelubricate all transfer case internal components with Jeep Dexron II or petroleum jelly where indicated. Do not use chassis lubricant or similar "heavy" type lubricants.*

(1) Install new input gear and rear output shaft bearing oil seals. Seat seals flush with edge of seal bore or in seal groove in case. Coat seal lips with petroleum jelly after installation.

(2) Install input gear thrust bearing race in case counterbore (fig. 2D-62).

(3) Install input gear thrust bearing on input gear and install gear and bearing in case (fig. 2D-62).

(4) Install mainshaft thrust bearing in bearing recess in input gear (fig. 2D-61).

(5) Install planetary assembly on input gear. Be sure planetary pinion teeth mesh fully with input gear (fig. 2D-61).

(6) Install planetary thrust washer on planetary hub (fig. 2D-60).

(7) Install new sector shaft O-ring and retainer in shaft bore in case.

(8) Install range sector in front case (fig. 2D-63). Install operating lever on sector shaft and install lever attaching washer and locknut on shaft. Tighten locknut to 17 foot-pounds (23 N•m) torque.

(9) Install detent spring, ball and retaining bolt in front case detent bore. Tighten bolt to 22 foot-pounds (30 N•m) torque (fig. 2D-10).

(10) Move range sector to last detent position.

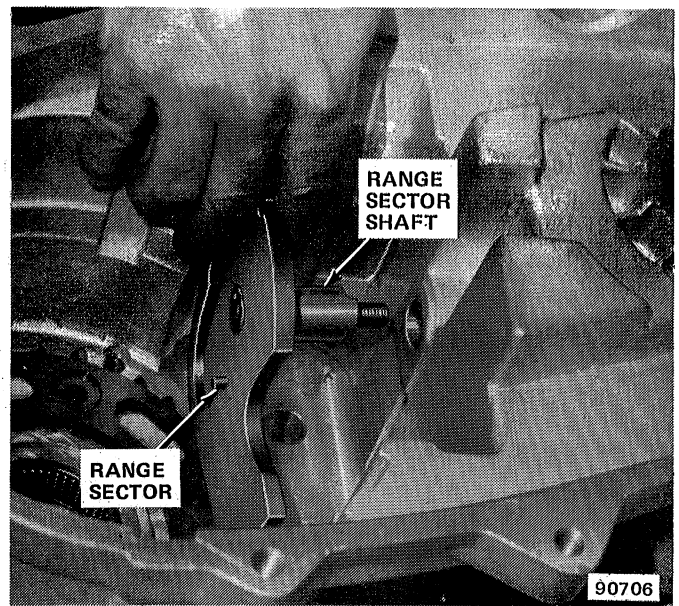

Fig. 2D-63 Range Sector Installation

(11) Assemble annulus gear and range fork. Install assembled fork and gear on and over planetary assembly. Be sure annulus gear is fully meshed with planetary pinions (fig. 2D-59).

(12) Insert range fork lug in range sector detent slot (fig. 2D-21).

(13) Install annulus thrust washer and annulus retaining ring on annulus gear hub (fig. 2D-58).

(14) Align mainshaft thrust washer in input gear, if necessary.

(15) Install mainshaft. Be sure shaft is fully seated in input gear.

(16) Install mainshaft thrust washer on mainshaft (fig. 2D-64).

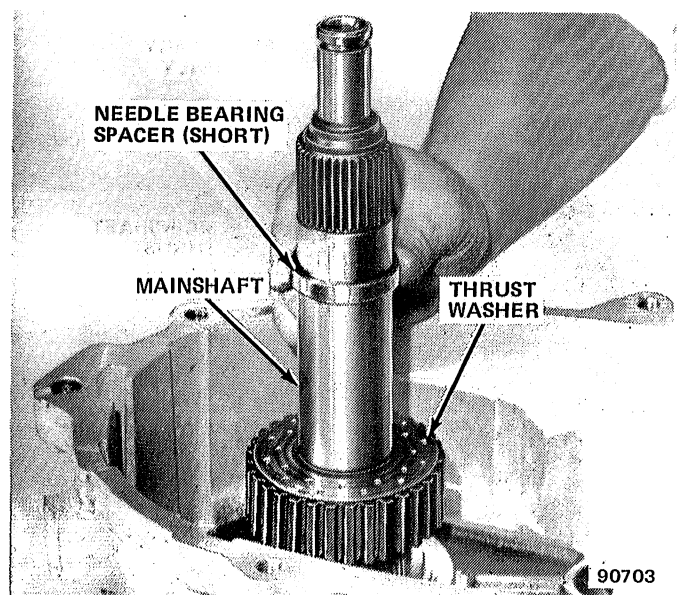

Fig. 2D-64 Mainshaft and Thrust Washer Installation

(17) Apply liberal coating of petroleum jelly to mainshaft needle bearing surface and to all 82 needle bearings. Install 41 bearings on shaft. Be sure bearings are in vertical position and seat on mainshaft. Use additional petroleum jelly to hold bearings in place if necessary (fig. 2D-65).

(18) Install long mainshaft needle bearing spacer on shaft (fig. 2D-65). Lower spacer onto previously installed needle bearings carefully to avoid displacing bearings.

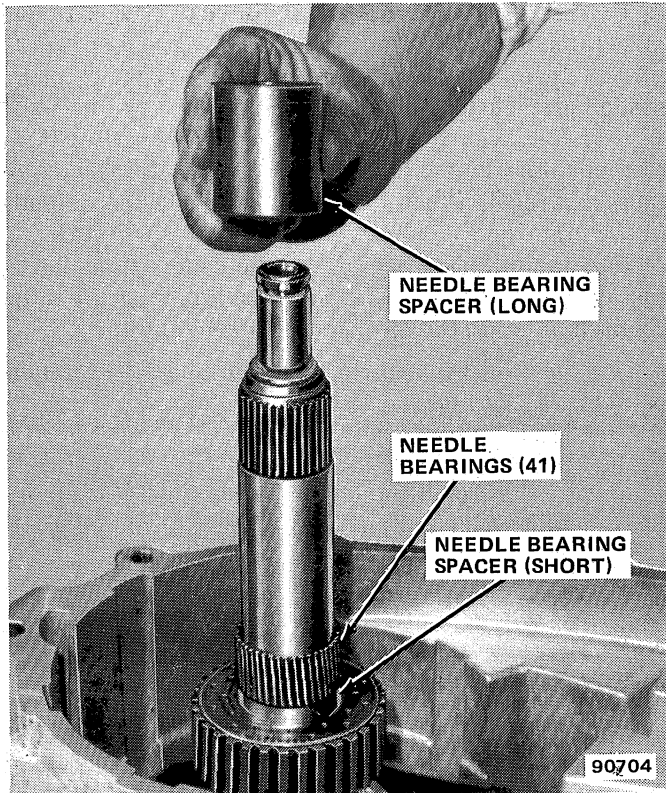

Fig. 2D-65 Mainshaft Needle Bearings and Spacer Installation

(19) Align shift rail bore in case with bore in range fork and install shift rail.

NOTE: Remove all traces of oil from the case shift rail bore before installing the rail. Oil in the case bore may prevent the rail from seating completely and prevent rear case installation.

(20) Assemble mode fork, mode fork spring and mode fork bracket (fig. 2D-66).

(21) Install clutch sleeve in mode fork (fig. 2D-56). Be sure sleeve is positioned so I.D. numbers on sleeve face upward after sleeve is installed.

(22) Align clutch sleeve and mode fork assembly with shift rail and install assembly on shift rail and mainshaft. Be sure clutch sleeve is meshed with mainshaft gear.

(23) Lubricate remaining 41 mainshaft needle bearings and position bearings on shaft. Use additional petroleum jelly to hold bearings on shaft, if necessary.

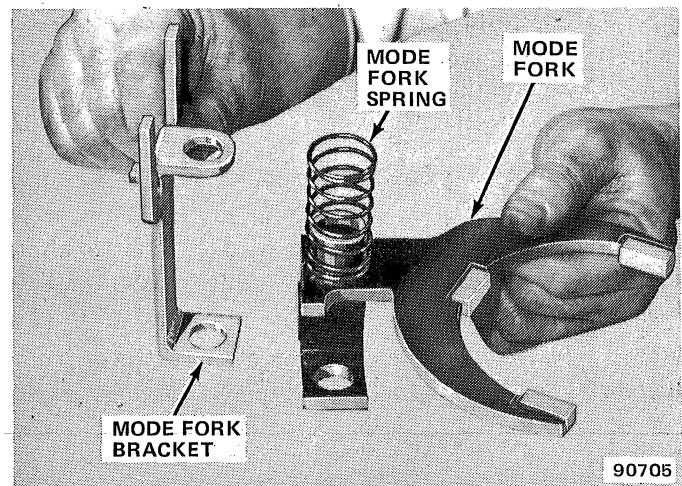

Fig. 2D-66 Assembling Mode Fork, Spring and Bracket

(24) Install side gear clutch on mainshaft with clutch gear teeth facing downward (fig. 2D-54). Be sure gear teeth mesh with clutch sleeve.

(25) Install remaining short mainshaft needle bearing spacer. Install spacer carefully to avoid displacing previously installed bearings.

(26) Install front output shaft front thrust bearing assembly in front case. Correct installation sequence is thick race-thrust bearing-thin race.

(27) Install front output shaft in front case (fig. 2D-55).

(28) Install clutch gear on side gear (fig. 2D-53). Tapered side of clutch gear teeth must face side gear teeth.

(29) Install clutch gear and drive sprocket locating snap rings on side gear. Install snap rings so snap rings face each other (fig. 2D-53).

(30) Position drive and driven sprockets in drive chain and install assembled side and clutch gears in drive sprocket (fig. 2D-52).

(31) Install assembled drive chain, sprockets and side gear on mainshaft and front output shaft (fig. 2D-51). Align sprockets with shafts, keep assembly level and carefully lower assembly onto both shafts simultaneously. Take care to avoid displacing mainshaft needle bearings during installation.

(32) Install driven sprocket retaining snap ring (fig. 2D-50).

(33) Install front output shaft rear thrust bearing assembly on front output shaft. Correct installation sequence is thin race-thrust bearing-thick race (fig. 2D-49).

(34) Install shift rail spring on shift rail.

(35) Install new O-ring on mainshaft pilot bearing hub (fig. 2D-48).

(36) Coat mainshaft pilot roller bearing hub and pilot roller bearings with liberal quantity of petroleum jelly and install rollers on shaft. Use enough petroleum jelly to hold bearing rollers on shaft (fig. 2D-48).

(37) Install rear output shaft in viscous coupling. Be

sure shaft is fully seated.

(38) Install assembled viscous coupling and rear output shaft on mainshaft (fig. 2D-48). Align mainshaft pilot hub with pilot bearing bore in rear output shaft and carefully lower assembly onto mainshaft. Take care to avoid displacing pilot roller bearings during installation.

(39) Align clutch gear teeth with viscous coupling teeth and seat coupling fully onto clutch gear (fig. 2D-67).

NOTE: *When correctly installed, the clutch gear teeth will not be visible or extend out of the coupling.*

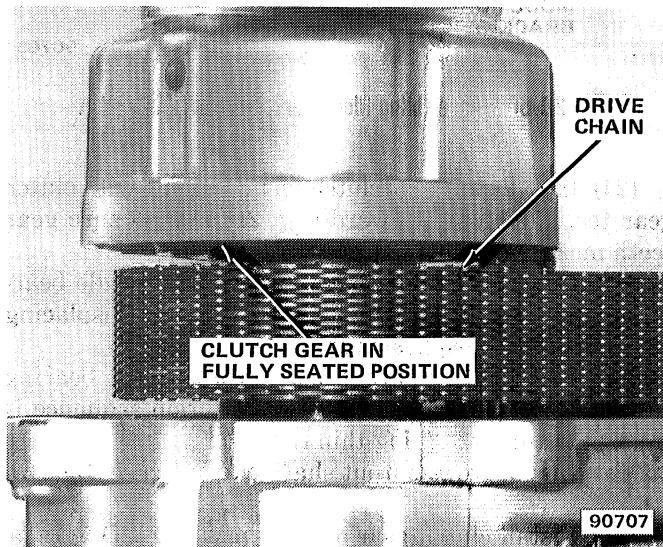

Fig. 2D-67 Seating Viscous Coupling on Clutch Gear

(40) Install magnet in front case, if removed.

(41) Clean mating surfaces of front and rear cases thoroughly.

(42) Apply Loctite 515, or equivalent sealant, to mating surface of front case and to all case attaching bolts.

(43) Install rear case on front case. Align case dowels and install case attaching bolts. Tighten bolts to 22 foot-pounds (30 N•m) torque.

NOTE: *The two case-end dowel bolts require flat washers.*

(44) Install oil pump on rear output shaft and seat it in case. Install pump so side with recess faces interior of case (fig. 2D-45).

(45) Install speedometer drive gear and differential shim on output shaft (fig. 2D-45).

(46) Install vent chamber seal in rear retainer, if removed.

(47) Align and install rear retainer on rear case. Tighten retainer bolts finger-tight only.

(48) Install yoke on rear output shaft. Tighten yoke nut finger-tight only.

(49) Mount Dial Indicator J-8001 on rear retainer.

Position indicator stylus so it contacts top of yoke nut (fig. 2D-68).

(50) Install yoke on front output shaft and rotate front shaft ten complete revolutions.

(51) Rotate front output shaft again and note end play registered on dial indicator. End play should be 0.002 to 0.010 inches (0.05 to 0.25 mm). If end play is correct, go to next step. If end play must be adjusted, remove rear retainer, add or subtract differential shims as required, and check end play again.

(52) Remove both output shaft yokes. Discard old yoke nuts.

(53) Install new front and rear yoke seals if not installed previously.

(54) Remove rear retainer bolts, apply Loctite 515, or equivalent sealant, to mating surface of retainer and to bolts and reinstall bolts. Tighten bolts to 22 foot-pounds (30 N•m) torque.

(55) Install new yoke seal washers on output shafts, install yokes on shafts and install new yoke nuts. Tighten nuts to 110 foot-pounds (149 N•m) torque.

(56) Install drain plug. Tighten plug to 35 foot-pounds (47 N•m) torque.

(57) Pour 4 pints (1.9 liters) of AMC/Jeep Automatic Transmission Fluid or equivalent labeled Dexron II® into transfer case through fill plug hole, and install fill plug. Tighten plug to 35 foot-pounds (47 N•m) torque.

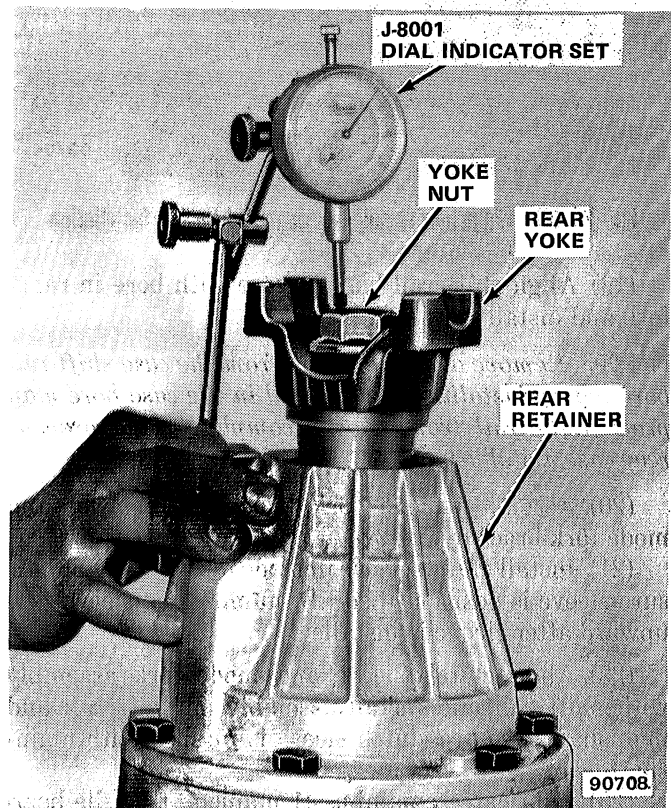

Fig. 2D-68 Checking Differential End Play

SPECIFICATIONS

Specifications—Model 219 Quadra-Trac Transfer Case

Transfer Case Type	4 position, dual range, full time 4-wheel drive unit with integral low range and a neutral and lock position	Drive Positions and Shift Controls	4H, 4L, Neutral, Lock. Ranges selected via floor mounted shift lever (4H range is fully differentiated. 4L and Lock ranges are undifferentiated)
Torque Transmittal Mode	Dual sprockets with connecting drive chain and an interaxle differential — viscous coupling unit	Lubricant Capacity and Type	4 pints (1.9 liters) Jeep, Dextron II Automatic transmission fluid only.
Low Range Reduction Ratio and Mode	2.61:1 through annulus gear and planetary carrier assembly		90769

Torque Specifications

Service Set-To Torques should be used when assembling components. Service In-Use Recheck Torques should be used for checking a pre-tightened item.

	USA (ft-lbs)		Metric (N·m)	
	Service Set-To Torque	Service In-Use Recheck Torque	Service Set-To Torque	Service In-Use Recheck Torque
Detent Retainer Bolt	23	20-25	31	27-34
Drain and Fill Plugs	35	30-40	47	40-54
Front/Rear Yoke Nuts	120	90-130	163	122-176
Indicator Switch	18	15-20	24	20-34
Operating Lever Locknut	18	14-20	24	19-27
Rear Case-to-Front Case Bolts (All)	23	20-25	31	27-34
Rear Retainer Bolts	23	20-25	31	27-34

All torque values given in foot-pounds and newton-meters with dry fits unless otherwise specified.

90620

MODEL 300 TRANSFER CASE

	Page		Page
Assembly	2D-45	In-Vehicle Service	2D-38
Cleaning and Inspection	2D-44	Lubrication	2D-38
Disassembly	2D-41	Power Flow	2D-38
General	2D-37	Service Diagnosis	2D-38
Identification	2D-38	Specifications	2D-47

GENERAL

The model 300 transfer case is used in CJ and Scrambler models only. It is a gearbox unit having the gears positioned in a layshaft-type of arrangement. The 300 has a cast iron case, four gear positions and employs an external floor mounted gearshift linkage for range con-

trol. The 300 is a part-time four-wheel drive unit providing four-wheel high and low ranges, a neutral position and two-wheel high range. The four-wheel high and low ranges are undifferentiated. Manual locking front hubs are standard equipment with this transfer case. In addition, the 300 is used with both manual and automatic

transmission applications. In four-wheel low range, reduction ratio is 2.6:1.

Transfer Case Shift Pattern

Transfer case shifting is controlled by a floor mounted shift lever located on the floorpan transmission tunnel. The shift pattern is in a straight line for all CJ and Scrambler models (fig. 2D-69). Shift knob sequence is 4H (four-wheel high), 2H (two-wheel high), N (neutral) and 4L (four-wheel low).

IDENTIFICATION

An identification tag that displays the vendor and Jeep part numbers is attached to the intermediate shaft lockplate bolt. This information is necessary to obtain correct service replacement parts.

LUBRICATION

The model 300 lubricant should be changed and the level inspected at the intervals specified in the Maintenance Schedule. When adding lubricant or refilling the transfer case after service, use SAE 85W-90, API grade GL-5 gear lubricant only. Lubricant capacity of the model 300 is 4 pints (1.9 liters).

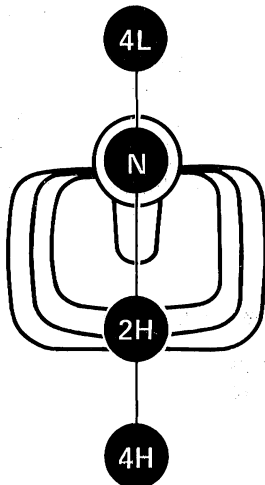

Fig. 2D-69 Transfer Case Shift Pattern—Model 300

POWER FLOW

In all drive ranges, incoming torque from the transmission is transmitted to the geartrain through the input shaft and rear output shaft gear (fig. 2D-70).

In 2H range, the front output shaft clutch sleeve is not shifted and remains in a neutral position. The rear output shaft clutch sleeve is shifted into engagement with the input gear. Torque flows from the input shaft and gear through the sleeve and to the rear output shaft and yoke. The intermediate gear idles on the input gear but does not transfer torque to the front output shaft. This occurs because the front shaft sleeve is in neutral and

the front output gear idles on the intermediate gear.

In 4H range, both clutch sleeves are shifted into engagement with the front and rear output shaft gears. Torque flows through the input shaft and rear output shaft gear to the larger intermediate gear. This intermediate gear transmits torque to the front output shaft through the front output shaft gear which is meshed with the larger intermediate gear.

In 4L range, the path of torque is similar to 4H range but with one major exception. In this range, the clutch sleeves are shifted into engagement with the front and rear output shaft clutch gears. Torque transfer now flows from the input shaft to the front and rear output shafts through the clutch gears. The clutch gears are now meshed with the smaller intermediate gear to produce a gear reduction ratio of 2.6:1.

SERVICE DIAGNOSIS

Before attempting to repair a suspected transfer case malfunction, check all other drive line components beforehand. The actual cause of a problem may be related to such items as the front hubs, axles, propeller shafts, wheels and tires, transmission, engine, or clutch instead. If all drive line components are in good condition and operating properly, refer to the Service Diagnosis charts for further information.

IN-VEHICLE SERVICE

Shift Rod Oil Seal Replacement

- (1) If left-side shift rod seal is to be replaced, shift transfer case into 4L position.
- (2) Raise vehicle.
- (3) Remove clevis pins connecting control links to transfer case shift rods.
- (4) Remove shift rod oil seal using Tool J-25175 (fig. 2D-71).
- (5) Install replacement seal using Thimble and Driver Tool J-25167 (fig. 2D-72).
- (6) Install clevis pins connecting control links to transfer case shift rods. Use replacement cotter pins to secure pins.
- (7) Lower vehicle.

Front—Rear Yoke Oil Seal Replacement

- (1) Raise vehicle.
- (2) Place support stand under transmission and remove rear crossmember.
- (3) Disconnect front or rear propeller shaft at the transfer case yoke. Place alignment marks on shaft and yoke for assembly reference before disconnecting shaft.
- (4) Remove transfer case yoke nut and washer using Tool J-8614-01 (fig. 2D-73).
- (5) Remove transfer yoke using Tools J-8614-01, 02, 03, (fig. 2D-74).

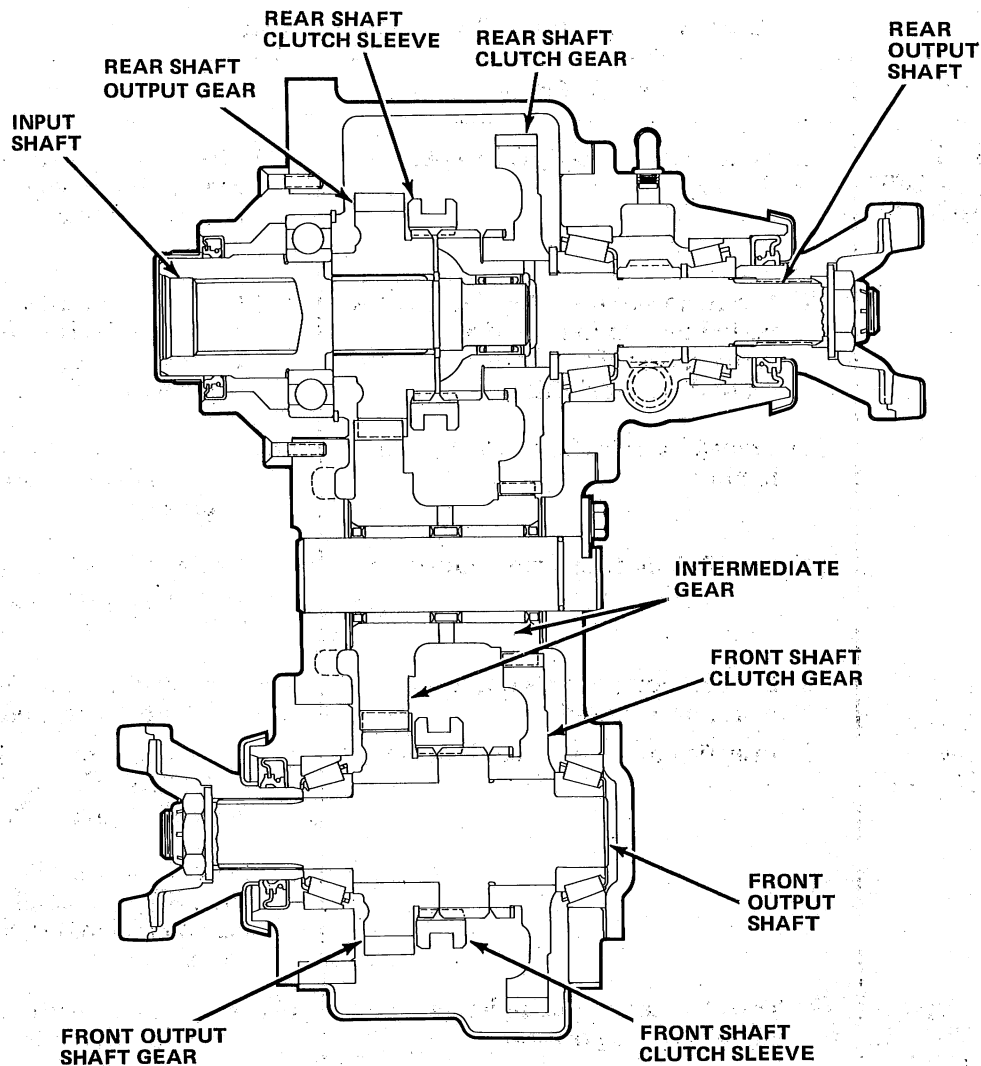

Fig. 2D-70 Power Flow—Model 300

- (6) Remove oil seal using Tool J-25180 (fig. 2D-75).
- (7) Install replacement seal using Tool J-25160.
- (8) Install yoke, washer and nut. Tighten nut to 120 foot-pounds (163 N•m) torque. Use Tool J-8614-01 to hold yoke while tightening nut.

Rear Bearing Cap—Speedometer Drive Gear Service

Removal

- (1) Disconnect rear propeller shaft at transfer case yoke. Tie shaft to frame with wire.
- (2) Disconnect speedometer cable.
- (3) Remove speedometer driven gear sleeve and driven gear.
- (4) Remove transfer case vent hose.
- (5) Remove output shaft yoke using Tools J-8614-01, -02, -03.
- (6) Remove bearing cap-to-transfer case bolts and remove bearing cap.

NOTE: The bearing cap has been coated with a sealant. Use a putty knife to break the seal, and work the knife around the bearing cap to loosen and remove it.

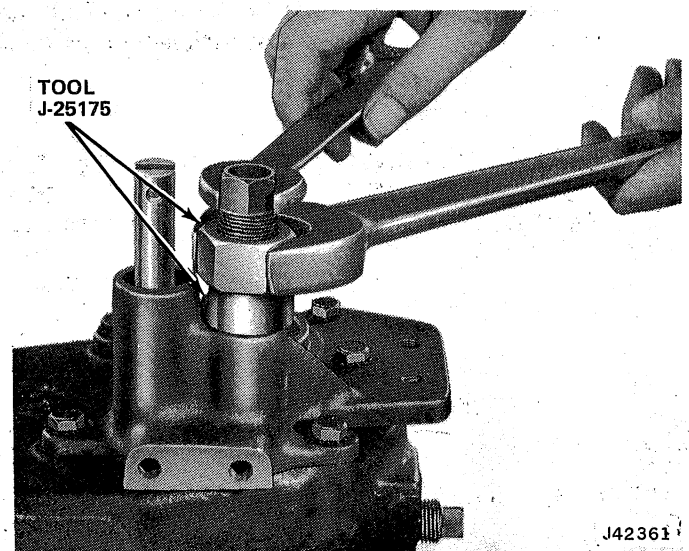

Fig. 2D-71 Shift Rod Oil Seal Removal

Service Diagnosis — Model 300 Transfer Case

Condition	Possible Cause	Correction
TRANSFER CASE DIFFICULT TO SHIFT OR WILL NOT SHIFT INTO DESIRED RANGE	(1) Vehicle speed too great to permit shifting. (2) If vehicle was operated for extended period in 4H mode on dry paved surface, driveline torque load may cause difficult shifting. (3) Transfer case external shift linkage binding. (4) Insufficient or incorrect lubricant. (5) Internal components binding, worn, or damaged.	(1) Stop vehicle and shift into desired range. Or reduce speed to 2-3 mph (3-4 km/h) before attempting to shift. (2) Stop vehicle, shift transmission to neutral, shift transfer case to 2H mode and operate vehicle in 2H on dry paved surfaces. (3) Lubricate or repair or replace linkage, or tighten loose components as necessary. (4) Drain and refill to edge of fill hole with SAE 85W-90 gear lubricant only. (5) Disassemble unit and replace worn or damaged components as necessary.
TRANSFER CASE NOISY IN ALL DRIVE MODES	(1) Insufficient or incorrect lubricant.	(1) Drain and refill to edge of fill hole with SAW 85W-90 gear lubricant only. Check for leaks and repair if necessary. Note: If unit is still noisy after drain and refill, disassembly and inspection may be required to locate source of noise.
NOISY IN — OR JUMPS OUT OF FOUR WHEEL DRIVE LOW RANGE	(1) Transfer case not completely engaged in 4L position. (2) Shift linkage loose or binding. (3) Shift fork cracked, inserts worn, or fork is binding on shift rail.	(1) Stop vehicle, shift transfer case in Neutral, then shift back into 4L position. (2) Tighten, lubricate, or repair linkage as necessary. (3) Disassemble unit and repair as necessary.
LUBRICANT LEAKING FROM OUTPUT SHAFT SEALS OR FROM VENT	(1) Transfer case overfilled. (2) Vent closed or restricted. (3) Output shaft seals damaged or installed incorrectly.	(1) Drain to correct level. (2) Clear or replace vent if necessary. (3) Replace seals. Be sure seal lip faces interior of case when installed. Also be sure yoke seal surfaces are not scored or nicked. Remove scores, nicks with fine sandpaper or replace yoke(s) if necessary.
ABNORMAL TIRE WEAR	(1) Extended operation on dry hard surface (paved) roads in 4H range.	(1) Operate in 2H on hard surface (paved) roads.

90770A

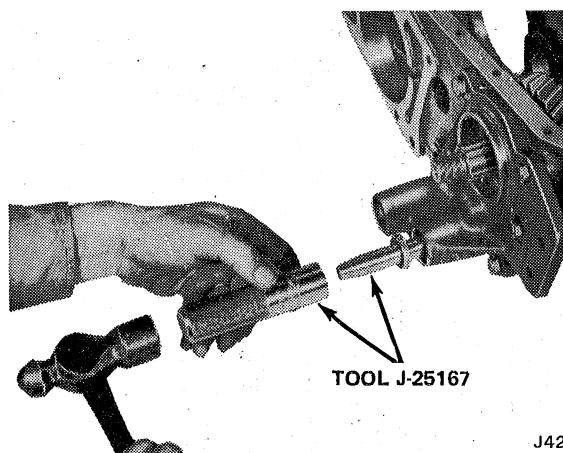

Fig. 2D-72 Shift Rod Oil Seal Installation

J42362

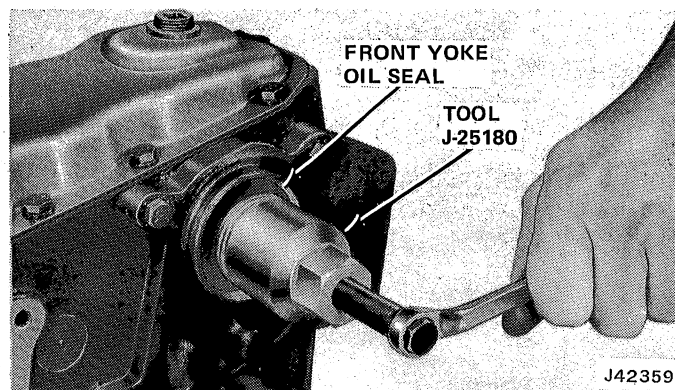

Fig. 2D-75 Yoke Oil Seal Removal

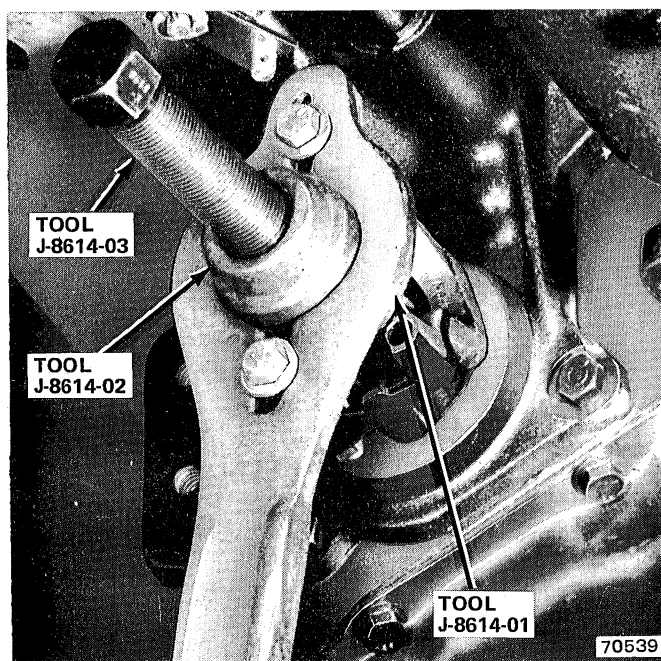

Fig. 2D-73 Output Shaft Yoke Nut Removal

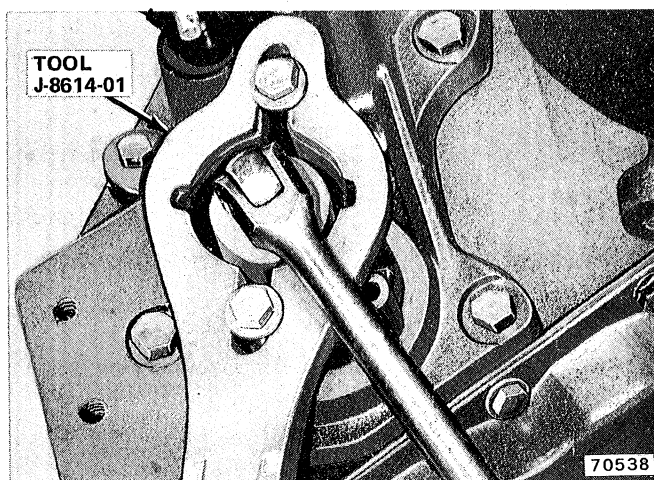

Fig. 2D-74 Yoke Removal

(7) Remove shims and speedometer drive gear from output shaft.

NOTE: *Keep the shims together for use in assembly.*

(8) Remove speedometer driven gear bushing from bearing cap, if necessary.

Installation

(1) Install speedometer driven gear bushing using Tool J-25169 if bushing was removed.

(2) Install speedometer drive gear and shims on shaft.

(3) Apply a bead of Loctite 515, or equivalent sealant, to mating surface of cap and install cap. Use two cap screws to align bolt holes. Use plastic mallet to tap cap into position.

(4) Tighten bearing cap bolts to 35 foot-pounds (47 N•m) torque.

(5) Install output shaft yoke and tighten locknut to 120 foot-pounds (163 N•m) torque. Use Tool J-8614-01 to hold yoke while tightening nut.

(6) Check rear output shaft end play as follows:

(a) Attach Dial Indicator J-8001 to bearing cap and position indicator stylus against output shaft.

(b) Pry output shaft back and forth to check end play. End play should be 0.001 to 0.005 inches (0.025 to 0.127 mm).

(c) If end play is not correct, remove or add shims between speedometer drive gear and output shaft rear bearing.

(7) Install transfer case vent hose.

(8) Install speedometer driven gear sleeve and driven gear.

(9) Install speedometer cable.

(10) Install rear propeller shaft. Tighten clamp strap bolts to 16 foot-pounds (21 N•m) torque.

DISASSEMBLY

- (1) Remove shift lever assembly.
- (2) Remove bottom cover (fig. 2D-76).

NOTE: The bottom cover has been coated with a sealant. Use a putty knife to break the seal, and work the knife around the bottom cover to loosen and remove it. Do not wedge the cover off.

(3) Remove front and rear yokes using Tool J-8614-01 (fig. 2D-74). Discard yoke locknuts.

(4) Remove socket head screws attaching input shaft support to case and remove support, rear output shaft gear and input shaft as assembly (fig. 2D-77).

NOTE: The support has been coated with a sealant. Use a putty knife to break the seal, and work the knife around the support to loosen and remove it.

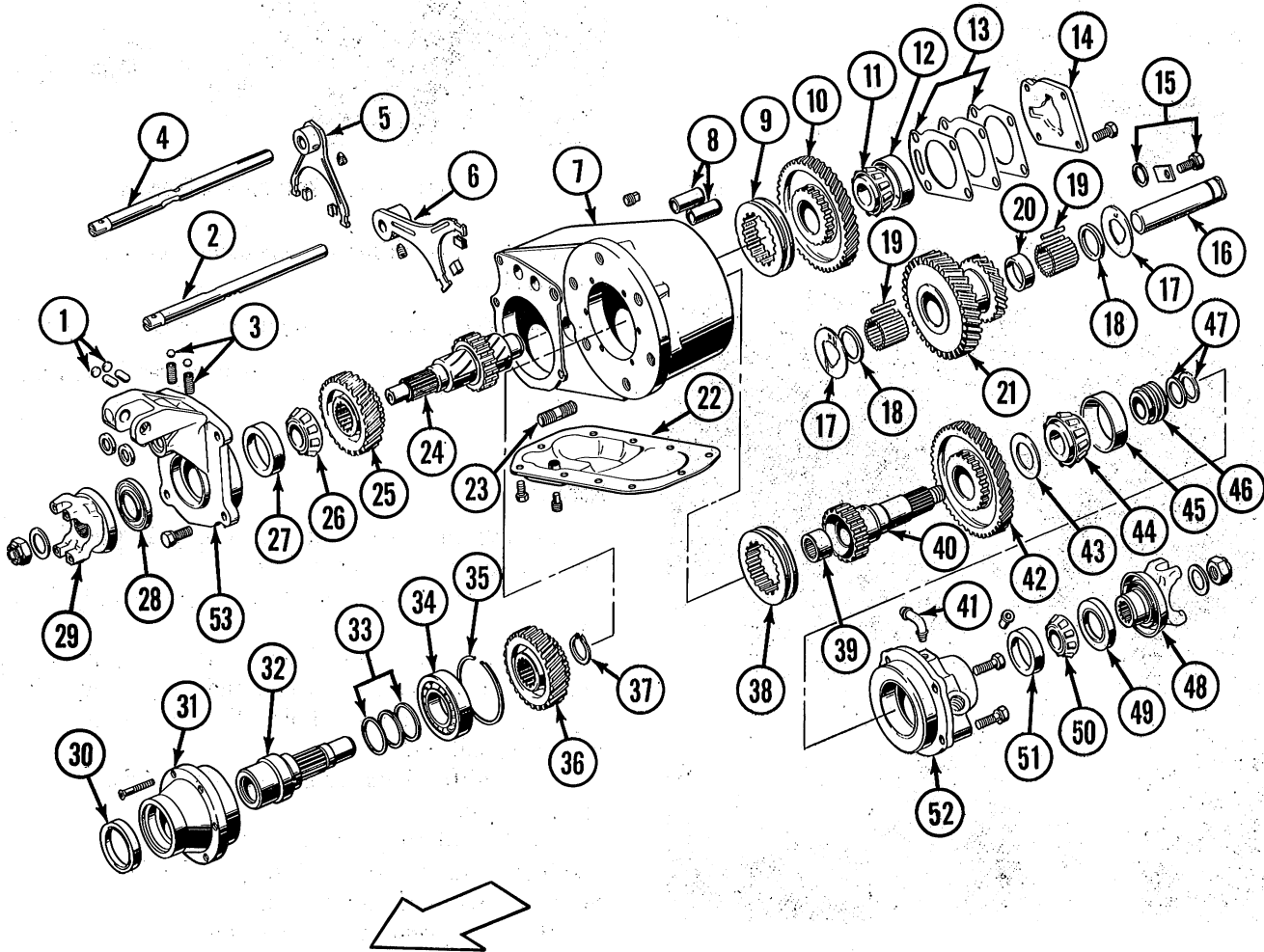

- 1. INTERLOCK PLUGS AND INTERLOCKS
- 2. SHIFT ROD - REAR OUTPUT SHAFT FORK
- 3. POPPET BALLS AND SPRINGS
- 4. SHIFT ROD - FRONT OUTPUT SHAFT FORK
- 5. FRONT OUTPUT SHAFT SHIFT FORK
- 6. REAR OUTPUT SHAFT SHIFT FORK
- 7. TRANSFER CASE
- 8. THIMBLE COVERS
- 9. CLUTCH SLEEVE - FRONT OUTPUT SHAFT
- 10. CLUTCH GEAR - FRONT OUTPUT SHAFT
- 11. BEARING - FRONT OUTPUT SHAFT REAR
- 12. RACE - FRONT OUTPUT SHAFT BEARING
- 13. END PLAY SHIMS - FRONT OUTPUT SHAFT
- 14. COVER PLATE
- 15. LOCK PLATE, BOLT AND WASHER
- 16. INTERMEDIATE GEAR SHAFT

- 17. THRUST WASHER
- 18. BEARING SPACER (THIN)
- 19. INTERMEDIATE GEAR SHAFT NEEDLE BEARINGS
- 20. BEARING SPACER (THICK)
- 21. INTERMEDIATE GEAR
- 22. BOTTOM COVER
- 23. STUD (CASE-TO-TRANS.)
- 24. FRONT OUTPUT SHAFT
- 25. FRONT OUTPUT SHAFT GEAR
- 26. FRONT OUTPUT SHAFT BEARING (FRONT)
- 27. FRONT OUTPUT SHAFT BEARING RACE
- 28. OIL SEAL
- 29. FRONT YOKE
- 30. SEAL
- 31. SUPPORT - INPUT SHAFT
- 32. INPUT SHAFT
- 33. SHIMS
- 34. INPUT SHAFT BEARING
- 35. INPUT SHAFT BEARING SNAP RING
- 36. REAR OUTPUT SHAFT GEAR

- 37. SNAP RING
- 38. CLUTCH SLEEVE - REAR OUTPUT SHAFT
- 39. INPUT SHAFT REAR BEARING (NEEDLE) (OR PILOT BEARING)
- 40. REAR OUTPUT SHAFT
- 41. VENT
- 42. CLUTCH GEAR - REAR OUTPUT SHAFT
- 43. THRUST WASHER
- 44. BEARING - REAR OUTPUT SHAFT FRONT
- 45. RACE - REAR OUTPUT SHAFT BEARING
- 46. SPEEDOMETER DRIVE GEAR
- 47. END PLAY SHIMS
- 48. REAR YOKE
- 49. REAR OUTPUT SHAFT OIL SEAL
- 50. BEARING - REAR OUTPUT SHAFT REAR
- 51. BEARING RACE
- 52. REAR BEARING CAP
- 53. FRONT BEARING CAP

Fig. 2D-76 Model 300 Transfer Case

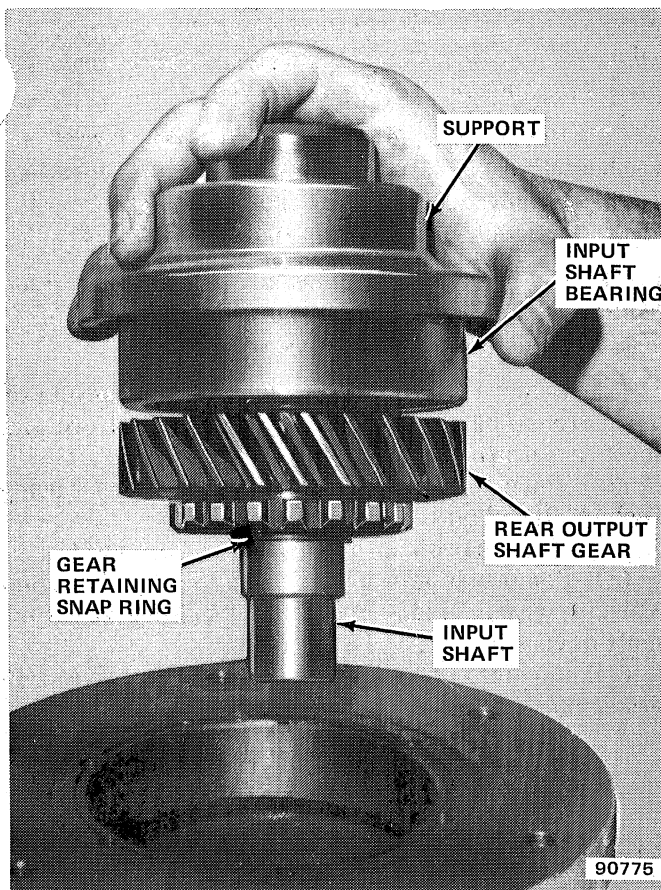

Fig. 2D-77 Front Support, Input Shaft and Rear Output Shaft Gear Removal/Installation

- (5) Remove rear output shaft clutch sleeve from case.
- (6) Remove and discard snap ring retaining rear output shaft gear on input shaft and remove gear.
- (7) Remove and discard input shaft bearing snap ring.
- (8) Remove input shaft and bearing from support. Tap end of input shaft with plastic mallet to aid removal.
- (9) Remove input shaft bearing and end play shims from shaft using arbor press.
- (10) Remove input shaft oil seal from support. Discard seal.
- (11) Remove intermediate shaft lockplate bolt and lockplate (fig. 2D-76).
- (12) Remove intermediate shaft. Tap shaft out of case using brass punch and plastic mallet.
- (13) Remove and discard intermediate shaft O-ring seal.
- (14) Remove intermediate gear assembly and thrust washers.

NOTE: Thrust washers have locating tabs which must fit in notches in the case at assembly.

- (15) Remove needle bearings and bearing spacers from intermediate gear.

NOTE: There are 48 needle bearings and three bearing spacers in the intermediate gear.

- (16) Remove rear bearing cap attaching bolts and remove cap. Use plastic mallet to tap on output shaft to aid cap removal.

NOTE: The rear bearing cap has been coated with a sealant. Use a putty knife to break the seal, and work the knife around the cap to loosen and remove it.

- (17) Remove end play shims and speedometer drive gear from rear output shaft (fig. 2D-76).

- (18) Remove and discard rear output shaft oil seal. Remove bearings and bearing races from rear bearing cap.

- (19) Remove setscrews retaining front and rear output shaft shift forks on shift rods (fig. 2D-78).

- (20) Remove shift rods. Insert punch through clevis pin holes in rods and rotate rods while pulling them out of case.

NOTE: When the shift rods are free of the front cap take care to avoid losing the shift rod poppet balls and springs.

- (21) Remove shift forks from case.

- (22) Remove bolts attaching front cap-to-case and remove front cap.

NOTE: The front cap has been coated with a sealant. Use a putty knife to break the seal, and work the knife around the cap to loosen and remove it.

- (23) Remove front output shaft and shift rod oil seals from front cap (fig. 2D-76). Discard seals.

- (24) Remove front bearing race from front bearing cap using Tool J-29168.

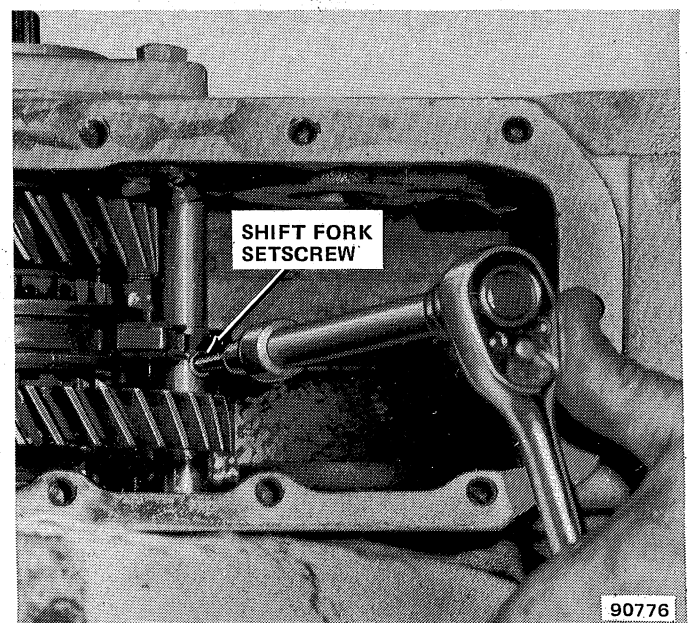

Fig. 2D-78 Shift Fork Setscrew Removal/Installation

(25) Remove cover plate bolts and remove plate and end play shims from case (fig. 2D-79). Keep shims together for assembly.

(26) Move front output shaft toward front of case.

(27) Remove front output shaft rear bearing race from case (fig. 2D-79).

(28) Remove rear output shaft front bearing. Position case on wood blocks. Seat clutch gear on case interior surface and tap shaft out of bearing using rawhide mallet (fig. 2D-80).

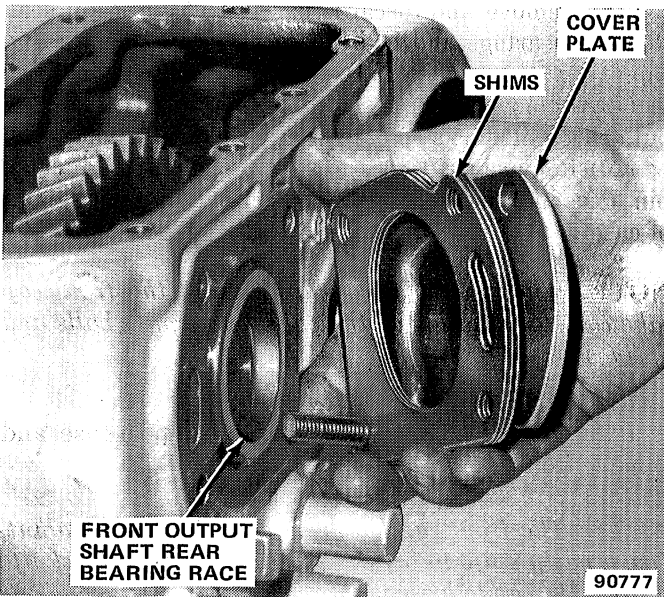

Fig. 2D-79 Cover Plate, Shims and Front Output Shaft Rear Bearing Race

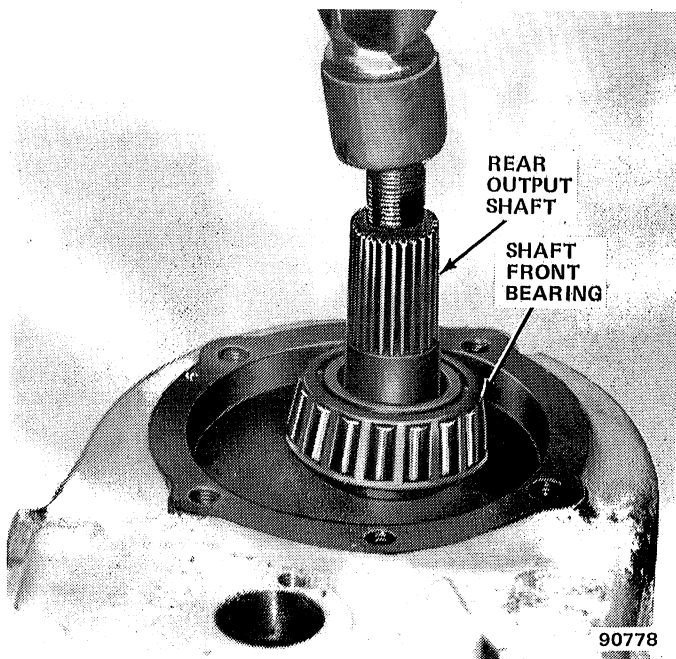

Fig. 2D-80 Rear Output Shaft Front Bearing Removal

NOTE: If the bearing proves difficult to remove, remove it using an arbor press and a suitable press tool to press the shaft out of the bearing.

(29) Remove rear output shaft front bearing, thrust washer, clutch gear and output shaft from case.

(30) Remove front output shaft rear bearing using arbor press and suitable press Tool (fig. 2D-81).

CAUTION: Be sure to support the case with wood blocks positioned at either side of the case bore. This is necessary to avoid damaging the case.

(31) Remove transfer case from arbor press and remove front output shaft, clutch gear and sleeve and shaft rear bearing from case.

(32) Remove front output shaft front bearing using Tool J-22912-01 and arbor press.

(33) Remove front output shaft gear from shaft.

(34) Remove input shaft rear needle bearing from rear output shaft using Tool J-29369-1. Support output shaft in vise during bearing removal.

(35) Remove shift rod thimbles. Use 3/8 drive, 7/16 socket and extension to tap shift rod thimbles out of case.

CLEANING AND INSPECTION

Clean the case and all components in solvent. Remove

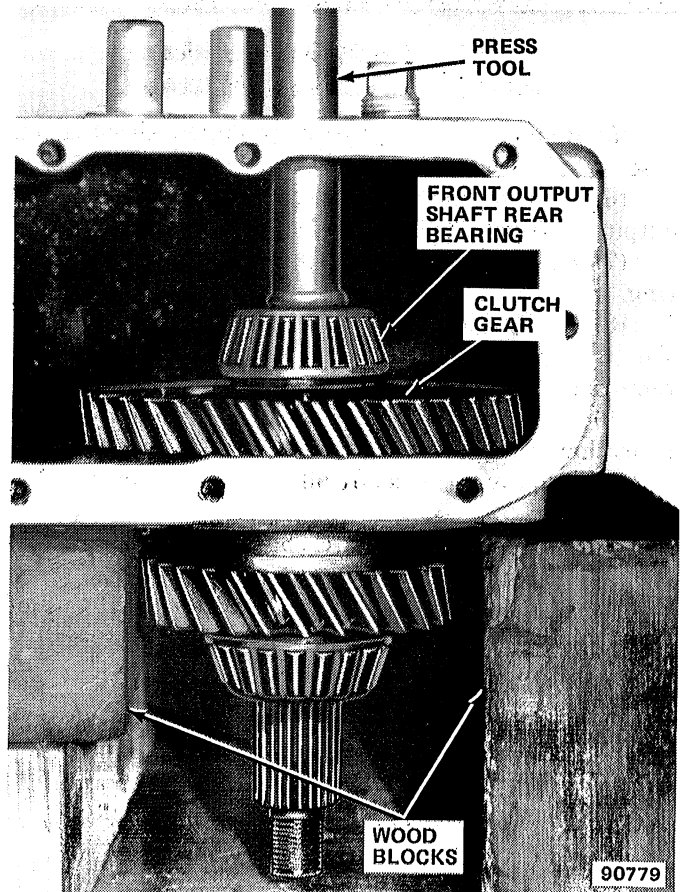

Fig. 2D-81 Front Output Shaft Rear Bearing Removal

all old sealing material from the case and bearing cap mating surfaces. Dry all components except the bearings, using compressed air. Use caution when cleaning the case mating surfaces. Do not scratch or mar these surfaces in any way. However, minor surface irregularities can be removed with sandpaper. Do not dry any bearings with compressed air. Use clean shop towels only.

Inspect all parts for signs of excessive wear or damage. Replace gears that are cracked, chipped broken or excessively worn. Replace any bearings that are worn, pitted, scored, flat-spotted, or brinelled. Replace any shaft that has damaged splines, threads or bearing surfaces. Check the shift rods and rod bores in the case for wear or damage. Minor scratches or nicks on the rods may be cleaned up using crocus cloth.

ASSEMBLY

(1) Install shift rod thimbles. Apply Loctite 220, or equivalent sealant, to thimbles before installation.

(2) Install front output shaft gear on front output shaft. Be sure clutch teeth on gear face shaft gear teeth.

(3) Install front bearing on front output shaft using arbor press and suitable press tool. Be sure bearing is seated against gear.

(4) Install front output shaft in case and install clutch sleeve and clutch gear on shaft.

(5) Install front output shaft rear bearing using arbor press and suitable press tool (fig. 2D-82).

NOTE: Install an old yoke nut on the shaft to avoid damaging the threads.

(6) Install input shaft rear needle bearing in rear output shaft using Tool J-29179.

(7) Position rear output shaft clutch gear in case and insert rear output shaft into gear.

(8) Install thrust washer and front bearing on rear output shaft using arbor press and suitable press tool.

(9) Install shims and bearing on input shaft using arbor press and suitable press tool.

(10) Install new input shaft oil seal in input shaft support using Tool J-29184.

(11) Install input shaft and bearing in support and install new bearing snap ring.

(12) Install rear output shaft gear on input gear and install new gear retaining snap ring (fig. 2D-77).

(13) Measure clearance between input gear and gear retaining snap ring using feeler gauge. Clearance should not exceed 0.003 inches (0.076 mm). If clearance is over tolerance, disassemble input shaft and add shims between input shaft and shaft bearing (fig. 2D-76).

(14) Install clutch sleeve on rear output shaft.

(15) Apply Loctite 515, or equivalent sealant, to mating surface of input shaft support and install assembled support, shaft and gear in case. Use two support bolts to align support on case and tap support into position using plastic mallet.

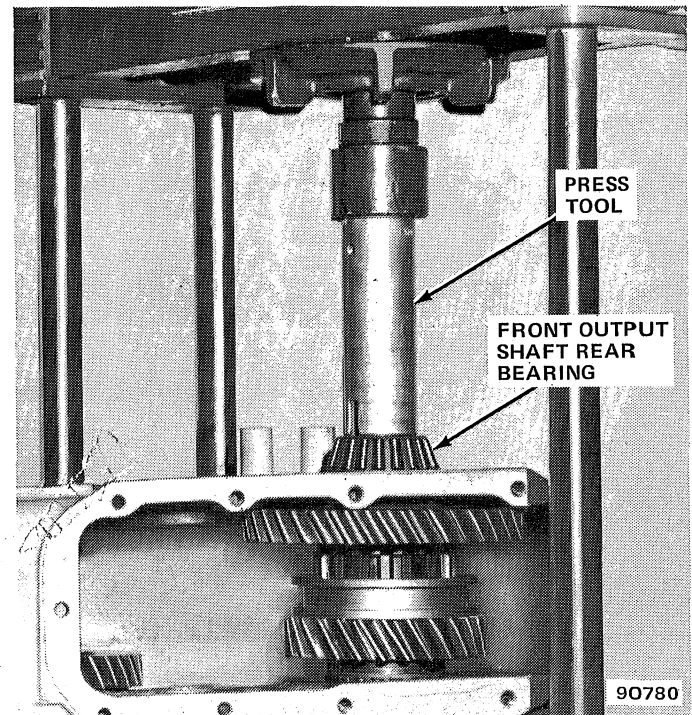

Fig. 2D-82 Front Output Shaft Rear Bearing Installation

(16) Install and tighten socket head screws in support to 10 foot-pounds (14 N•m) torque.

(17) Install rear bearing cap front bearing race using Tool J-9276-3.

(18) Install rear bearing cap rear bearing race using Tool J-29182.

(19) Position rear output shaft rear bearing in rear bearing cap.

(20) Install rear output shaft yoke oil seal using Tool J-25160.

(21) Install speedometer gear and end play shims on rear output shaft.

(22) Install rear bearing cap. Apply Loctite 515, or equivalent sealant, to mating surface of cap. Use two cap bolts to align bolt holes and tap rear cap into place using plastic mallet.

(23) Install and tighten rear bearing cap bolts to 35 foot-pounds (47 N•m) torque.

(24) Install rear output shaft yoke. Tighten new lock-nut to 120 foot-pounds (163 N•m) torque. Use Tool J-8614-01 to hold yoke while tightening nut.

(25) Check rear output shaft end play as follows:

(a) Clamp Dial Indicator J-8001 onto bearing cap. Position indicator stylus so it contacts end of shaft (fig. 2D-83).

(b) Pry output shaft back and forth to check end play. End play should be 0.001 to 0.005 inches (0.025 to 0.127 mm).

(c) If end play is not correct, remove or add shims between speedometer drive gear and output shaft rear bearing (fig. 2D-76).

(26) Install front output shaft rear bearing race (fig. 2D-79).

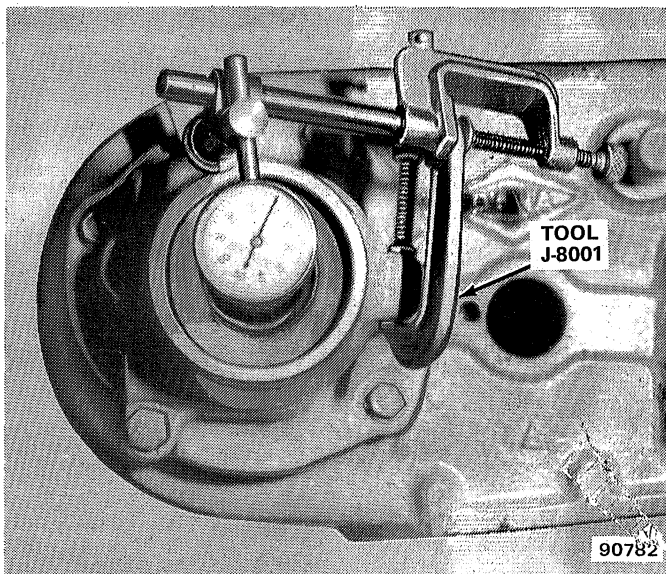

Fig. 2D-83 Checking Rear Output Shaft End Play

(27) Install front output shaft end, play shims and cover plate (fig. 2D-79). Tighten cover plate bolts to 35 foot-pounds (47 N•m) torque.

NOTE: Apply Loctite 220, or equivalent sealant, to bolt threads before installation.

(28) Install front output shaft front bearing race using Tools J-8092 and J-29181 (fig. 2D-84).

(29) Install front output shaft yoke oil seal using Tool J-25160.

(30) Install shift rod oil seals using Tool J-25167 (fig. 2D-72).

(31) Install front bearing cap. Apply Loctite 515, or equivalent sealant, to mating surface of cap before installation. Use two bolts to align cap and case bolt holes and tap cap into position on case using plastic mallet.

(32) Install and tighten bearing cap bolts to 35 foot-pounds (47 N•m) torque.

(33) Check front output shaft end play as follows:

(a) Seat rear bearing cup against cover plate by tapping end of front output shaft with plastic mallet.

(b) Mount dial indicator on front bearing cap and position indicator stylus against end of output shaft.

(c) Pry shaft back and forth to check end play. End play should be 0.001 to 0.005 inches (0.025 to 0.129 mm).

(d) If end play is not correct, remove or add shims between cover plate and case. If shims are added, seat rear bearing cup as outlined in step (a) before checking end play again.

(34) Install front output shaft yoke. Tighten new locknut to 120 foot-pounds (163 N•m) torque. Use Tool J-8614-01 to hold yoke while tightening nut.

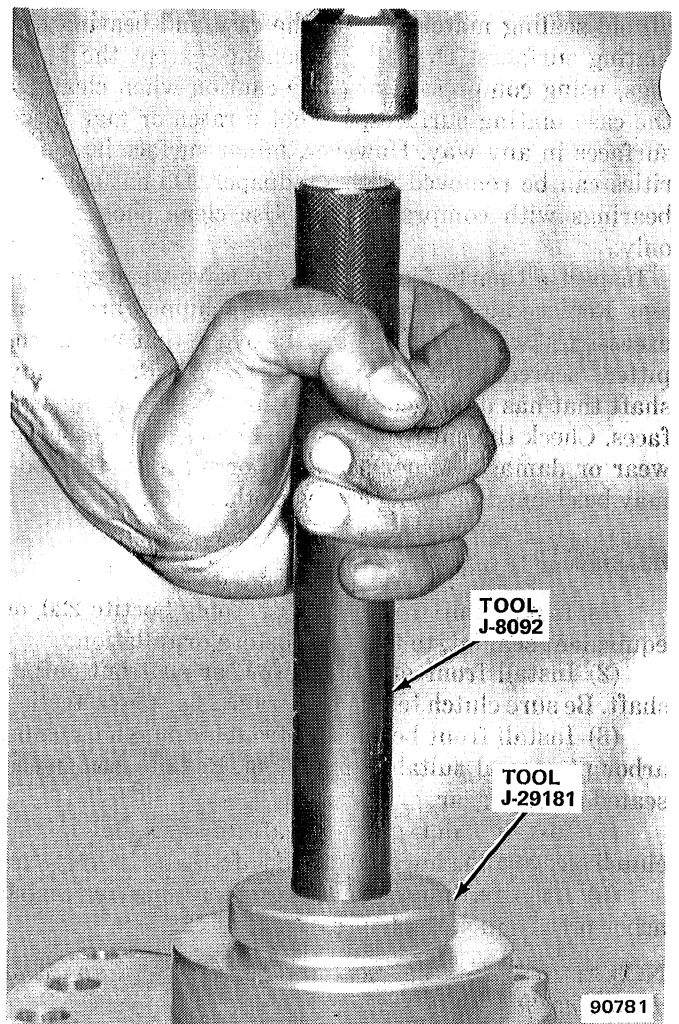

Fig. 2D-84 Front Output Shaft Front Bearing Race Installation

(35) Insert front and rear output shaft shift forks into case (fig. 2D-85).

(36) Install front output shaft shift rod poppet ball and spring in front bearing cap.

(37) Compress poppet ball and spring and install front output shaft shift rod part way in case.

(38) Insert front output shaft shift rod through shift fork.

(39) Align setscrew hole in shift fork and rod. Install and tighten setscrew to 14 foot-pounds (19 N•m) torque.

(40) Install rear output shaft shift rod poppet ball and spring in front bearing cap.

(41) Compress ball and spring and install rear output shaft shift rail part way in case.

NOTE: Before installing the shift rail, be sure the front output shaft shift rod is in Neutral and that the interlocks are seated in the front bearing cap bore.

(42) Insert rear output shaft shift rod through shift fork.

(43) Align setscrew holes in fork and rod. Install and tighten setscrew to 14 foot-pounds (19 N•m) torque.

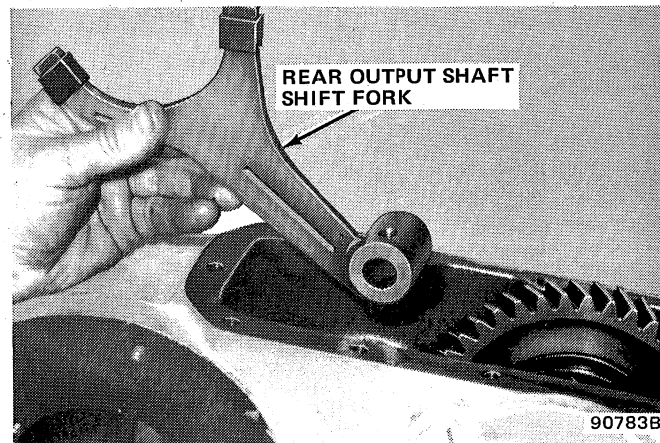
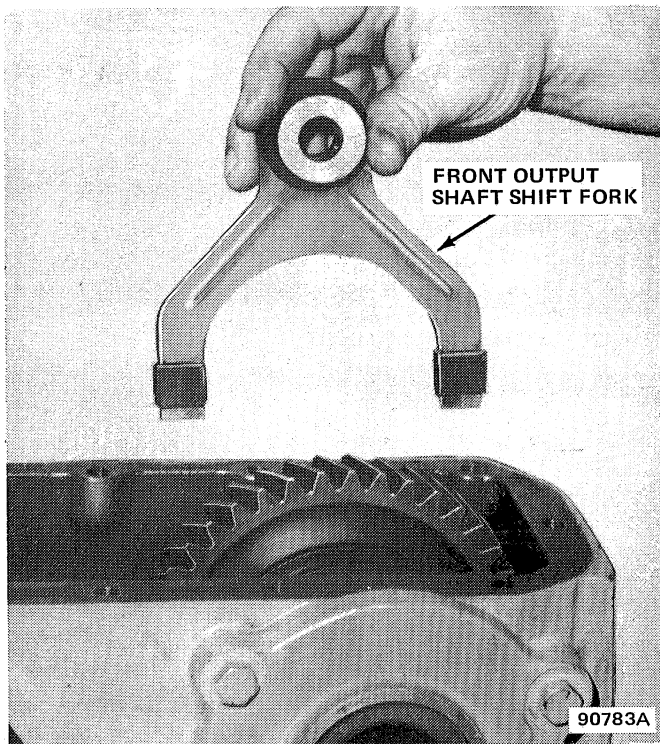

Fig. 2D-85 Shift Fork Installation

(44) Insert Tool J-25142 in intermediate gear and install needle bearings and spacers in gear.

(45) Install intermediate gear thrust washers in case. Be sure washer tangs are aligned with grooves in case.

NOTE: *The thrust washers can be held in place with petroleum jelly.*

(46) Install new O-ring seal on intermediate shaft.

(47) Position intermediate gear in case.

(48) Install intermediate shaft in case bore. Tap shaft into gear until shaft forces Tool J-25142 out of case. Use plastic mallet to tap shaft into place.

(49) Install intermediate shaft lockplate and bolt. Tighten bolt to 23 foot-pounds (31 N•m) torque.

(50) Install bottom cover and replacement gasket. Apply Loctite 515, or equivalent sealant, to mating surface of cover. Install and tighten cover bolts to 15 foot-pounds (20 N•m) torque.

SPECIFICATIONS

Specifications—Model 300 Transfer Case

Transfer Case Type4 position, dual range part time 4 wheel drive unit with integral low range
Torque Transmittal Mode	Constant mesh gearbox with layshaft gear arrangement.
Low Range Reduction Ratio2.6:1 gear reduction
Drive Positions and Shift Controls	2H, 4H, 4L and Neutral. Ranges selected via floor mounted shift lever. 4H and 4L ranges are undifferentiated
Case Configuration	One piece cast iron with aluminum front/rear bearing caps
Lubricant Capacity and Type	4 pints (1.9 liters) SAE 85W-90 gear lubricant API grade GL-5

90784

Torque Specifications

Service Set-To Torques should be used when assembling components. Service In-Use Recheck Torques should be used for checking a pre-tightened item.

USA (ft-lbs)

Metric (N-m)

	Service Set-To Torque	Service In-Use Recheck Torque	Service Set-To Torque	Service In-Use Recheck Torque
Bottom Cover Bolts	15	10-20	20	14-27
Cover Plate Bolts	35	25-40	47	34-54
Front Bearing Cap Bolts	35	25-40	47	34-54
Front/Rear Yoke Locknuts	120	120-150	163	163-203
Input Shaft Support Screws	10	7-10	14	9-14
Lockplate Bolt	23	20-25	31	27-34
Shift Fork Setscrews	14	12-18	19	16-24

All torque values given in foot-pounds and newton-meters with dry fits unless otherwise specified.

90785

Tools

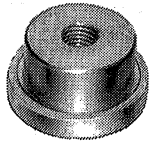

TOOL
J-29181

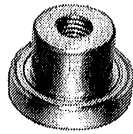

TOOL
J-29163

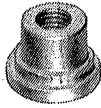

TOOL
J-29174

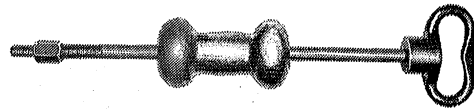

TOOL
J-2619-01



TOOL
J-8092

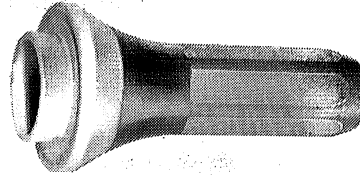

TOOL
J-29184 or
J-29162

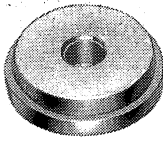

TOOL
J-9276-3

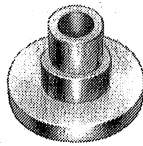

TOOL
J-29179

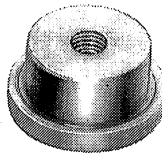

TOOL
J-29169



TOOL
J-8614-03

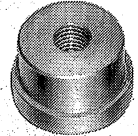

TOOL
J-29170

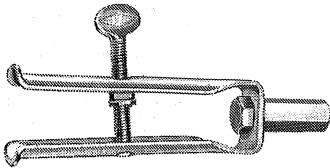

TOOL
J-26941



TOOL
J-25167

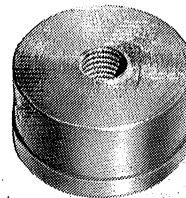

TOOL
J-29185

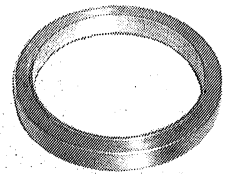

TOOL
J-29185-2

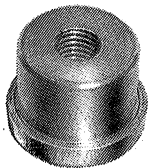

TOOL
J-29168

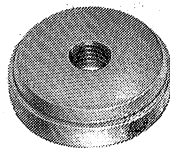

TOOL
J-7818

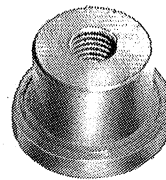

TOOL
J-25167

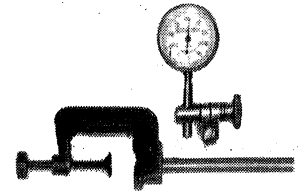

TOOL
J-8001

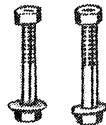

TOOL
J-8614-01

