

FUEL SYSTEMS

1J

SECTION INDEX

	Page		Page
Carburetor Model BBD—2 Venturi	1J-46	Feedback Systems	1J-83
Carburetor Model E2SE—2 Venturi	1J-30	General Information	1J-1
Carburetor Model 2SE—2 Venturi	1J-11	Positive Crankcase Ventilation (PCV) System	1J-78
Carburetor Model 2150—2 Venturi	1J-58	Thermostatically Controlled Air Cleaner (TAC) System	1J-80
Exhaust Gas Recirculation (EGR) System	1J-73	Tools	1J-148

GENERAL INFORMATION

	Page		Page
Air Cleaners	1J-1	Fuel Return System	1J-8
Fuel Economy Tests	1J-11	Fuel Tanks	1J-2
Fuel Filters	1J-1	Fuel Vapor Control Systems	1J-6
Fuel Gauge	1J-8	Specifications	1J-11
Fuel Pump	1J-8		

AIR CLEANERS

An air cleaner is necessary to protect the fuel system, as well as the moving parts of the engine, from the abrasive and clogging effects of dust, dirt and sediment normally present in the intake air supply.

The lower portion of the air cleaner is designed to reduce the noise emitted by air rushing through the carburetor to the intake system. The air cleaner also serves as a flame arrester in the event of a backfire up through the carburetor.

A replaceable filter element (paper-type) is used as standard equipment (figs. 1J-1 and 1J-2).

Replace the air cleaner filter element at the intervals listed in the Maintenance Schedule. More frequent replacement is advisable when the vehicle is operated in dusty areas or on unpaved roads.

The air cleaner intake duct contains the air valve for the Thermostatically Controlled Air Cleaner (TAC) System and trap door (if equipped). The operation and diagnosis of both systems are described within Thermostatically Controlled Air Cleaner (TAC) System section of this chapter. The thermal sensor is located on the inside base of the air cleaner housing.

Service

To clean the paper filter element, shake out accumulated dirt—**DO NOT WASH**. Use compressed air to carefully blow through the element from the inside toward the outside, opposite the direction of normal airflow.

Replace the air cleaner filter element more frequently than specified in the Maintenance Schedule if there is any apparent damage or evidence of being clogged.

FUEL FILTERS

All Jeep six- and eight-cylinder engine fuel systems are protected from the entry of dirt and other foreign matter through the carburetor fuel inlet by a replaceable 15-micron, pleated paper filter located in the carburetor fuel inlet pipe and secured by two short rubber hoses and clamps. Replace the filter at the intervals outlined in the Maintenance Schedule.

All vehicles with six- and eight-cylinder engines have a fuel return system that requires an extra nipple on the fuel filter to route fuel back to the fuel tank. The filter must be installed with the return nipple upward. Refer to Fuel Return System.

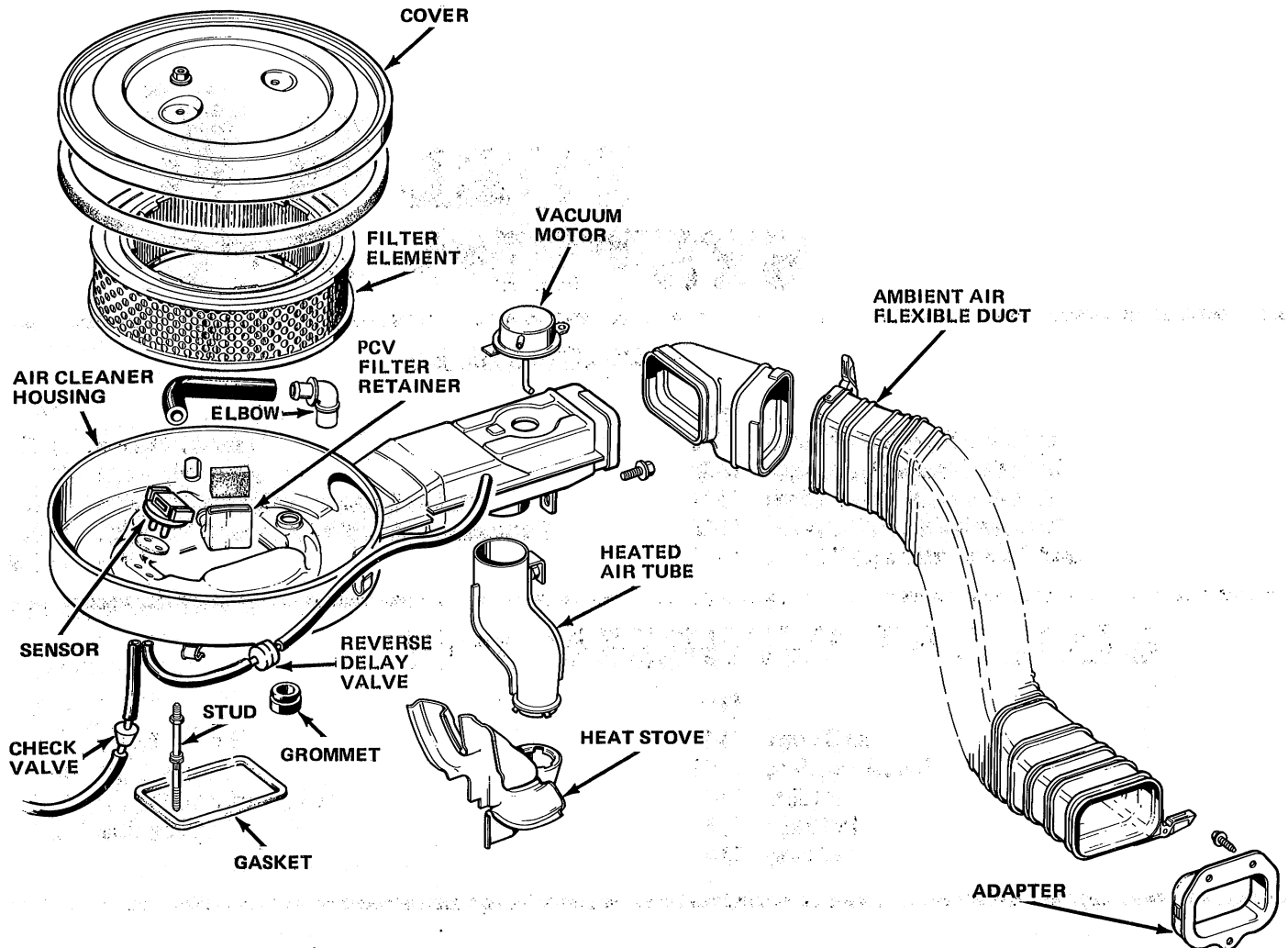

90644B

Fig. 1J-1 Carburetor Air Cleaner—Four-Cylinder Engines

The fuel filter for four-cylinder engines is located inside the carburetor. If allowed to become plugged, the result will be restricted fuel flow and loss of engine power. To replace the fuel filter follow the procedure listed below.

NOTE: Four-cylinder engines have no fuel return to the fuel tank. The sending unit fuel return nipple is capped.

Replacement—Four-Cylinder Engine

WARNING: Battery negative cable must be removed to prevent a potential fire hazard when fuel pipe is disconnected.

- (1) Disconnect battery negative cable.
- (2) Disconnect fuel pipe at fuel inlet filter fitting.
- (3) Remove fuel inlet filter fitting from carburetor.
- (4) Remove filter element and spring (fig. 1J-3).
- (5) Install replacement filter element and spring with hole in filter element toward fitting.
- (6) With new gasket on fitting, install fuel inlet fitting and tighten with 25 foot-pounds (34 N•m) torque.

(7) Install fuel pipe and tighten with 18 foot-pounds (24 N•m) torque while holding fuel inlet fitting with wrench.

(8) Connect battery negative cable.

WARNING: Use extreme caution when engine is operating. The fan, pulleys and belts can cause serious personal injury. Do not wear loose clothing. Do not stand in direct line with fan blades.

(9) Start engine and inspect for leaks.

Fuel Tank Filter

All vehicles use a woven Saran sleeve-type filter that is attached to the end of the fuel outlet tube inside the fuel tank. This filter is rated at 65 microns and repels water. Under normal conditions, it requires no maintenance or service.

FUEL TANKS

NOTE: All reference to CJ vehicles also pertains to Scrambler vehicles.

The fuel tank on all models is protected by a shield. Cherokee, Wagoneer and CJ models have two tank vents

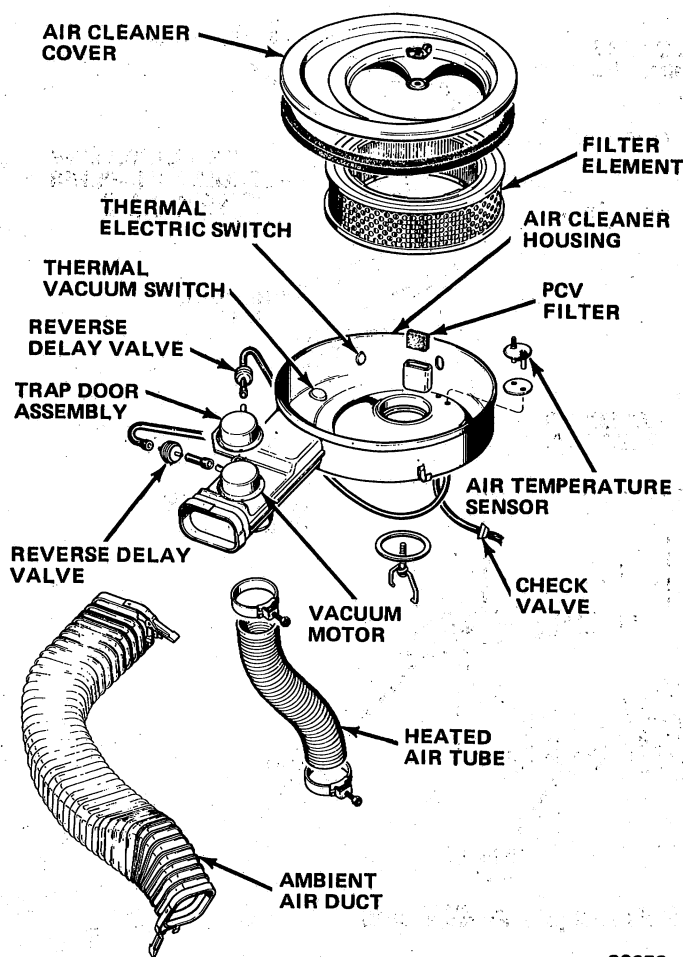

Fig. 1J-2 Typical Carburetor Air Cleaner—
Six- and Eight-Cylinder Engines

80273

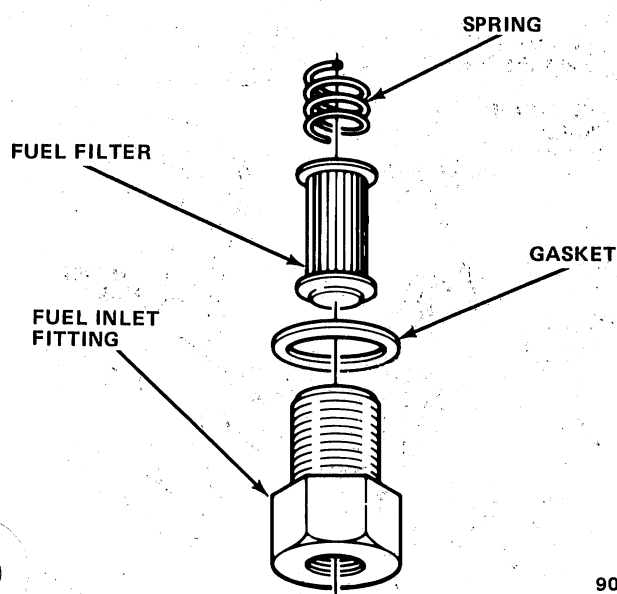

Fig. 1J-3 Four-Cylinder Engine Fuel Filter

90645

while Truck models have one vent. The various fuel tank and venting arrangements are illustrated in figures 1J-4, 1J-5 and 1J-6.

The fuel tanks are external expansion types that are vented by vapor hoses routed to the vapor canister. Refer to Fuel Vapor Control System.

Fuel Tank Replacement

Removal—CJ Vehicles

- (1) Position jack under shield and remove screws.
- (2) Disconnect fuel outlet and return hoses, fuel filler hose and filler vent hose.
- (3) Partially lower shield and tank and disconnect tank vapor vent hoses.
- (4) Disconnect fuel gauge sending unit wires, lower tank and remove.

Installation—CJ Vehicles

- (1) Position shield and tank on jack and partially raise.
- (2) Install fuel outlet hose, return hose, fuel gauge sending unit wires and tank vapor vent hoses.
- (3) Raise shield and tank to installation position, install screws and tighten.
- (4) Install fuel filler hose and filler vent hose.

Removal—Cherokee-Wagoneer Vehicles

- (1) Remove parking brake cable guide clips.
- (2) Disconnect one brake cable at connector.
- (3) Disconnect fuel filler hose.
- (4) Disconnect front drive shaft and position aside to allow clearance for tank removal.
- (5) Place jack under shield and tank and remove attaching hardware.
- (6) Lower shield and tank. Disconnect fuel gauge sending unit wires, fuel outlet hose and return hose.

Installation—Cherokee-Wagoneer Vehicles

- (1) Place shield and tank on jack. Connect fuel gauge sending unit wires, fuel outlet hose and return hose.
- (2) Raise shield and tank to installation position and secure with attaching hardware.
- (3) Connect fuel filler hose.
- (4) Connect parking brake cable.
- (5) Connect front drive shaft.

Removal—Truck Vehicles

- (1) Disconnect fuel filler hose, filler vent hose and tank vapor vent hose.
- (2) Place jack under shield and tank.
- (3) Loosen straps and lower shield and tank.
- (4) Disconnect fuel gauge sending unit wires, fuel outlet hose and fuel return hose.
- (5) Remove shield and tank.

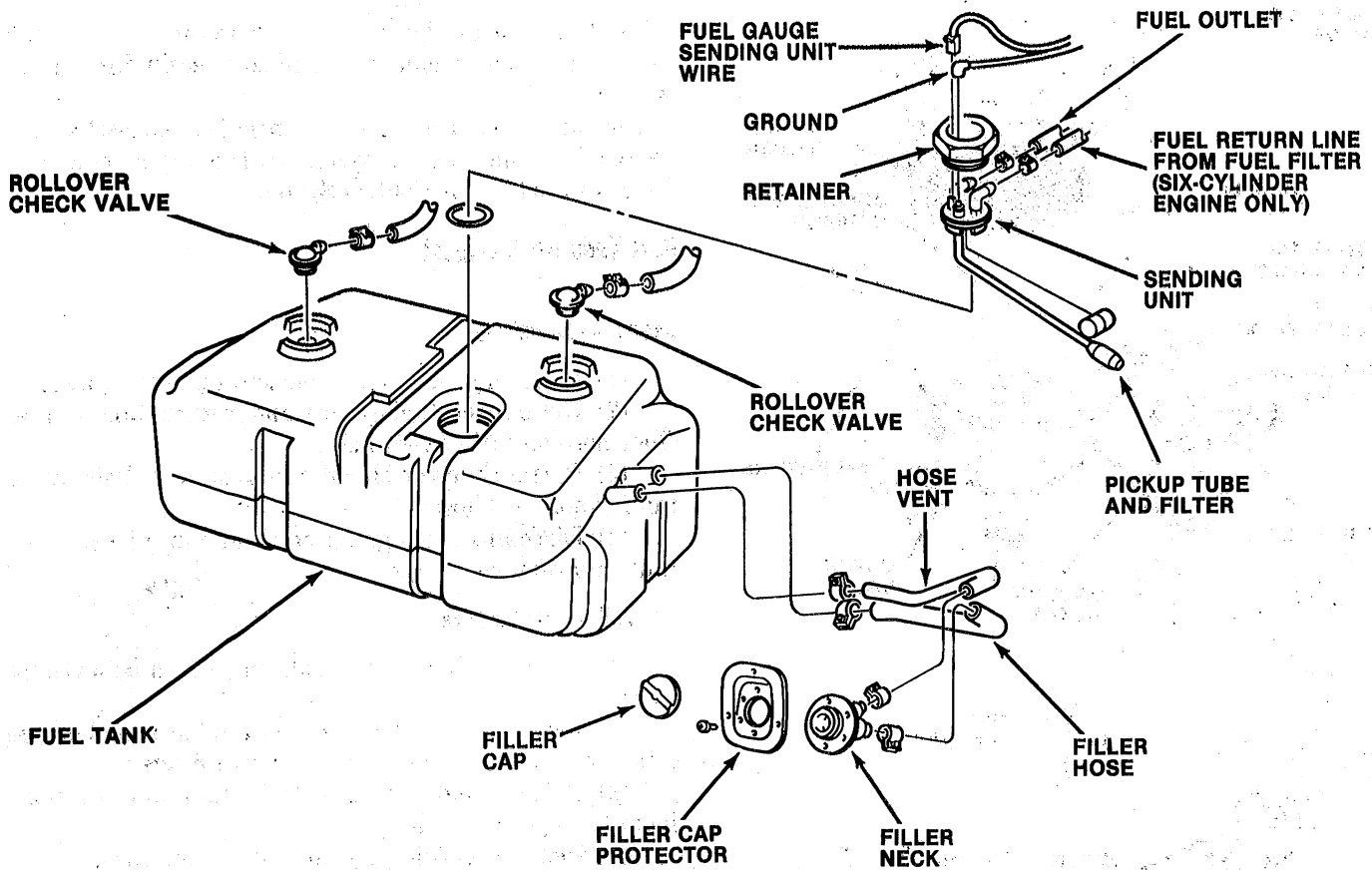

Fig. 1J-4 Fuel Tank and Associated Fuel System Components—CJ Vehicles

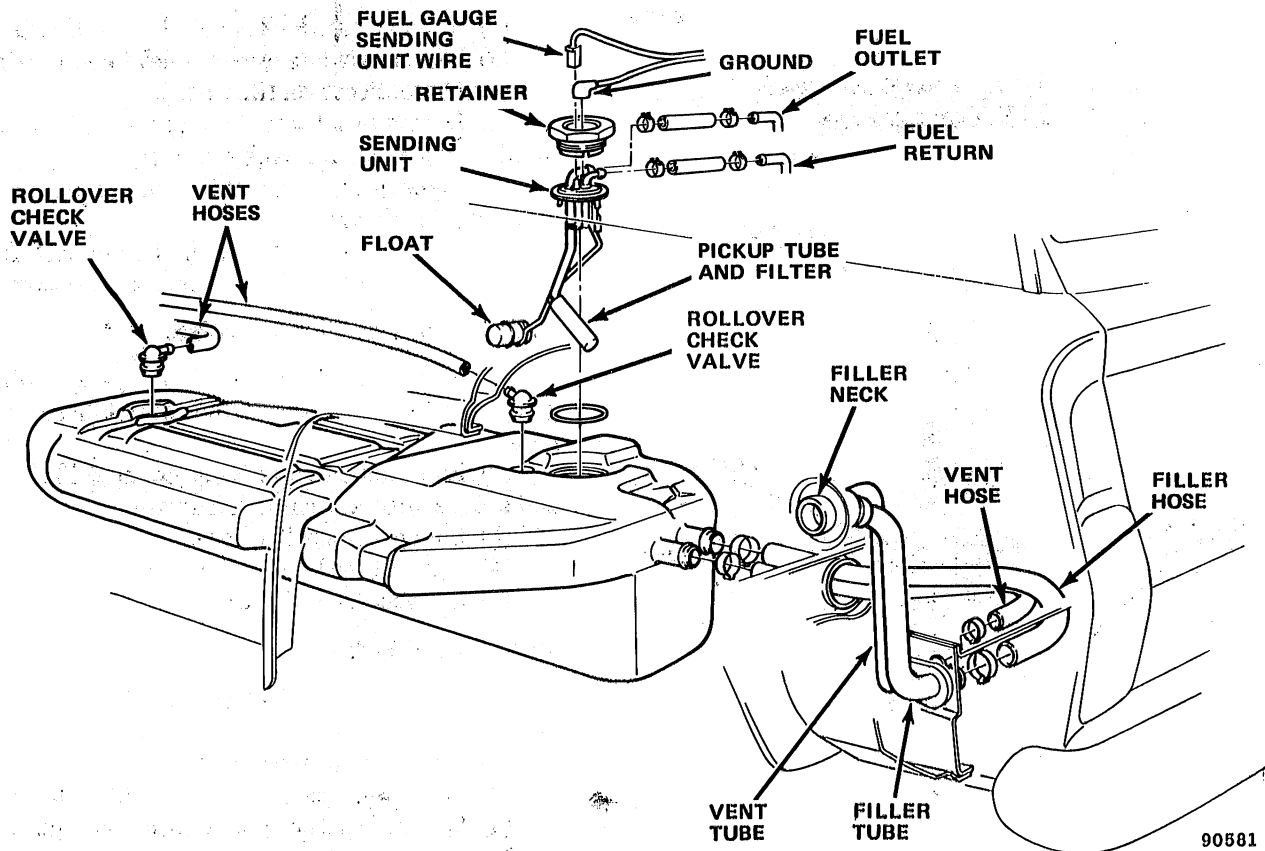

Fig. 1J-5 Fuel Tank and Associated Fuel System Components—Cherokee-Waggoner Vehicles

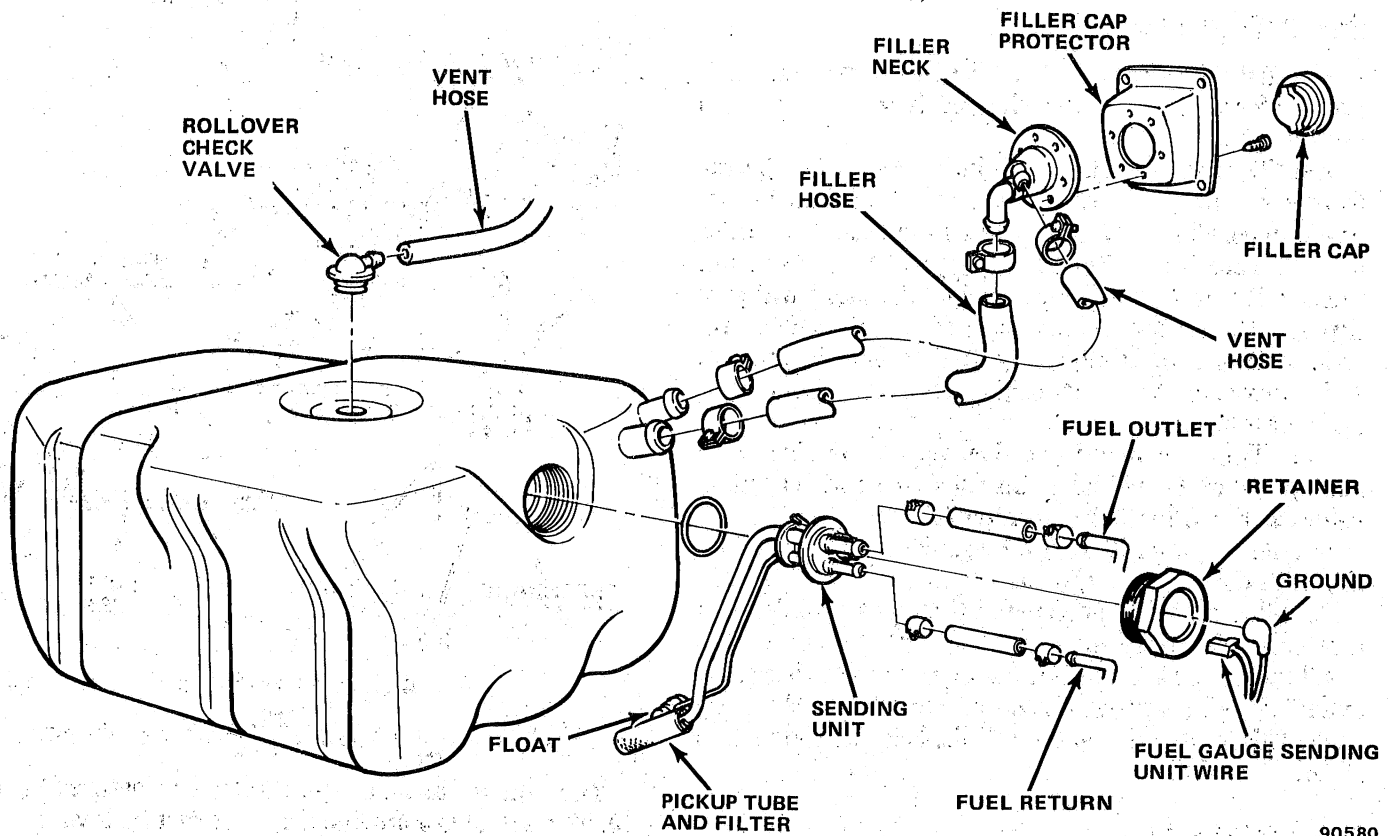

Fig. 1J-6 Fuel Tank and Associated Fuel System Components—Truck Vehicles

90580

Installation—Truck Vehicles

- (1) Install replacement clamps on filler and vent hoses and fuel outlet and return hoses.
- (2) Position shield and tank on jack.
- (3) Connect fuel outlet and return hoses and sending unit wires.
- (4) Raise shield and tank and install straps.
- (5) Connect filler and vent hoses to tank.

Fuel Gauge Sending Unit

The sending unit assembly utilizes a float that pivots on a variable resistance element.

The fuel pickup, fuel system nipples and the sending unit assembly are an integral unit that is mounted on a flanged opening on the fuel tank. For all vehicles, it is secured with a threaded retainer that must be tightened with a torque of 14 to 18 foot-pounds (19 to 24 N·m).

Removal—All Vehicles

- (1) Remove fuel tank according to removal procedures previously outlined.

- (2) With Tool J-23726, turn threaded retainer counterclockwise and remove.

- (3) Remove sending unit assembly (figs. 1J-4, 5 and 6).

Installation—All Vehicles

- (1) Position sending unit assembly in opening on top of tank (figs. 1J-4, 5 and 6).

NOTE: Ensure O-ring is properly positioned in groove. Replace improperly fitting ring.

- (2) Position threaded retainer, turn clockwise and, with Tool J-23726, tighten with a torque of 14 to 18 foot-pounds (19 to 24 N·m).

- (3) Install fuel tank according to installation procedures previously outlined.

NOTE: Ensure the sending unit fuel gauge and ground wires have a good electrical connection.

Fuel Tank Filler Neck

The fuel filler neck on all models has been designed to provide for vapor control during refilling and to improve the fill rate.

The filler neck for all models incorporates a restrictor to prevent entry of nozzles used with leaded fuel gasoline pumps. The restrictor reduces the size of the filler neck to a small opening that is covered by a trap door. The small diameter unleaded fuel pump nozzle will pass through the restrictor opening and push open the restrictor trap door to allow the fuel tank to be refilled. This protects the catalytic converter from contamination by leaded fuel.

The filler neck opening is located on the right rear body panel on CJ vehicles. On Cherokee and Wagoneer vehicles, the filler neck opening is located on the left rear quarter panel. On Truck vehicles, it is located on the left side of the pickup box.

The filler neck is connected to the fuel tank inlet by a hose secured with clamps.

All fuel tanks are equipped with a filler vent hose that extends from a fitting on top of the tank to the filler neck. This vent relieves the air displaced as the tank is filled.

Fuel Tank Filler Cap

The filler cap incorporates a two-way relief valve that is closed to the atmosphere during normal operating conditions. The relief valve is calibrated to open only when a pressure of 0.75 to 1.5 psi (5 to 10 kPa) or a vacuum of 1.1 to 1.8 in. Hg (4 to 6 kPa) occurs within the tank. When the pressure or vacuum is relieved, the valve returns to the normally closed position.

FUEL VAPOR CONTROL SYSTEMS

The fuel vapor control system prevents raw fuel vapor from escaping into the atmosphere. Fuel vapor from the fuel tank and carburetor bowl are collected in a canister and are metered into the intake manifold for combustion. On all vehicles, rollover check valves in the vent system prevent fuel from flowing out of the vent hoses if the vehicle is accidentally rolled over. The various typical components, depicted in figure 1J-7, are described below.

NOTE: The systems used with CJ and Truck vehicles are similar to that illustrated in figure 1J-7.

Components

Vapor Canister

This component is used on all vehicles. The canister is filled with granules of activated charcoal. Vapor entering the canister is absorbed by the granules.

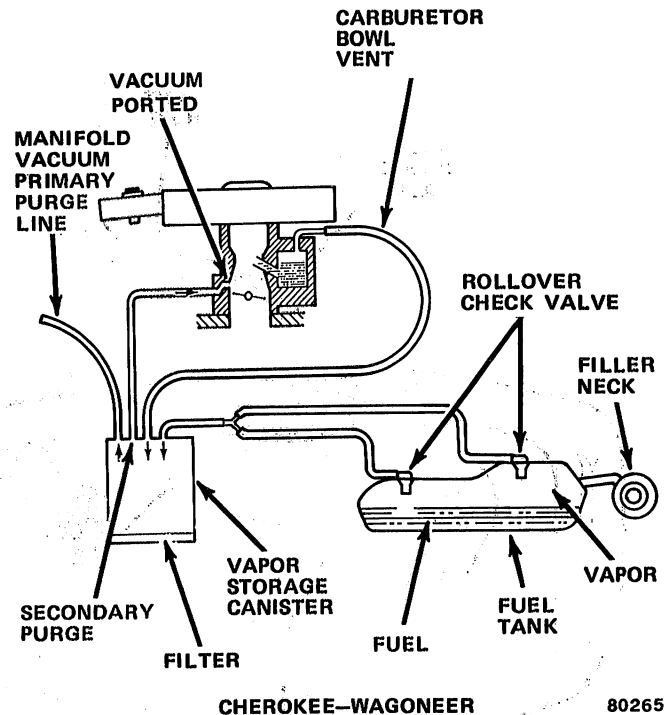

Fig. 1J-7 Fuel Vapor Control System—Cherokee-Wagoneer

The canister has a staged dual purge feature (fig. 1J-8). Two inlets are provided, one for fuel tank vapor and one for carburetor bowl vapor. The outlet is connected to an intake manifold vacuum source. The fourth nipple is connected to the carburetor spark port (ported vacuum).

When the engine is operating, fresh air enters through the inlet filter in the bottom of the canister and purges the stored vapor. When the ported vacuum reaches 12 in. Hg (41 kPa), the secondary purge circuit is opened, and the canister is purged at a much higher rate.

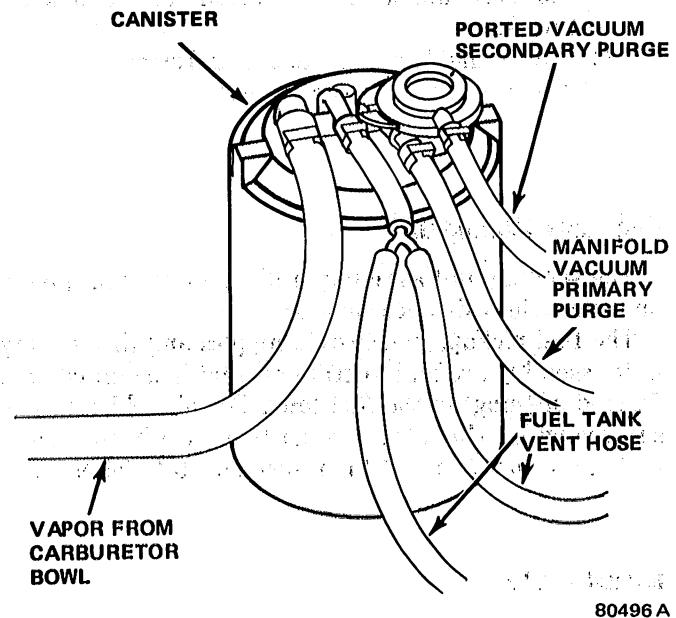

Fig. 1J-8 Fuel Vapor Control Canister and Hoses—Typical

80496 A

Rollover Check Valve

This component is used on all Jeep vehicles. The rollover check valve prevents fuel flow from the fuel tank through the vent hoses in the event of vehicle rollover. The check valve consists of a plunger and a stainless steel ball (figs. 1J-9 and 1J-10). When inverted, the stainless steel ball pushes the plunger against its seat. A properly functioning rollover valve will hold 3 psi (21 kPa) of air pressure on the inlet side when inverted.

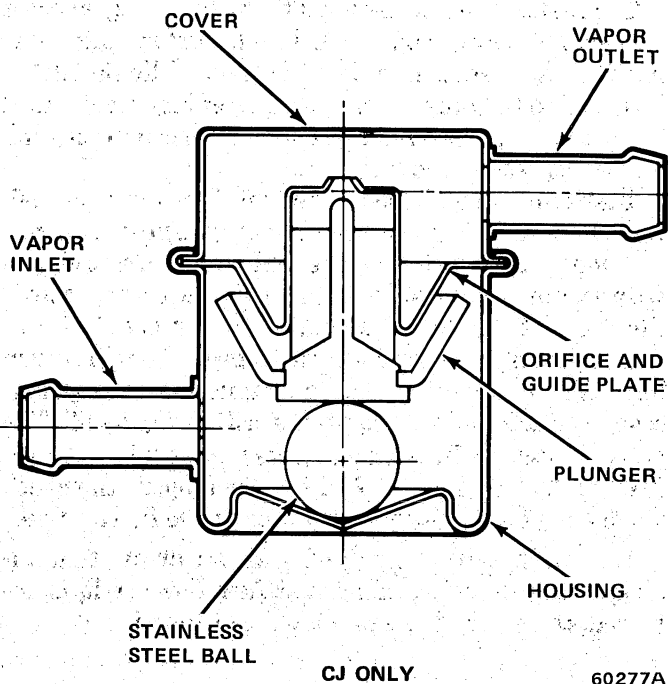

Fig. 1J-9 Rollover Check Valve—CJ Vehicles

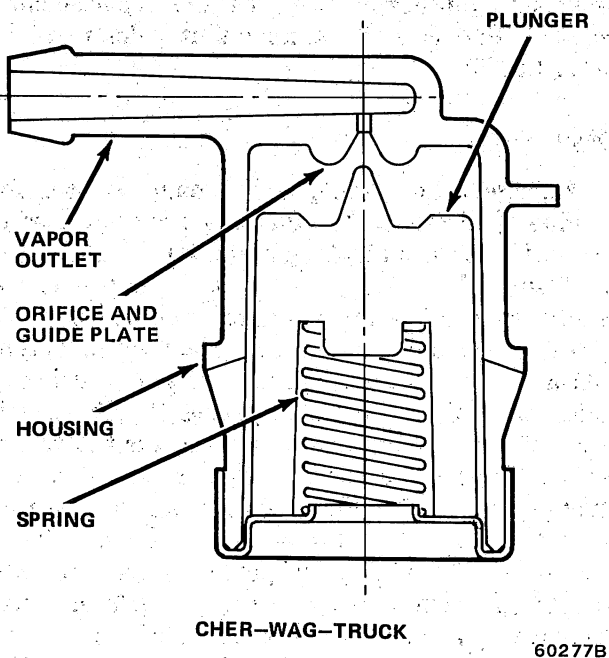

Fig. 1J-10 Rollover Check Valve—Cherokee-Wagoneer-Truck Vehicles

Carburetor External Bowl Vent

This component is used on all carburetors. The carburetor external bowl vent provides an outlet for fuel vapor when the engine is not operating (fig. 1J-11). If the vent were not provided, raw fuel vapor would enter the atmosphere. Some would also enter the intake manifold and cause difficult hot restarts. When the engine is operating, the fuel bowl must be vented to the inside of the air cleaner for proper fuel flow. This is accomplished by automatically closing the external bowl vent by a mechanical link from the throttle. Refer to Float Circuit in the applicable carburetor section for specific operating principles.

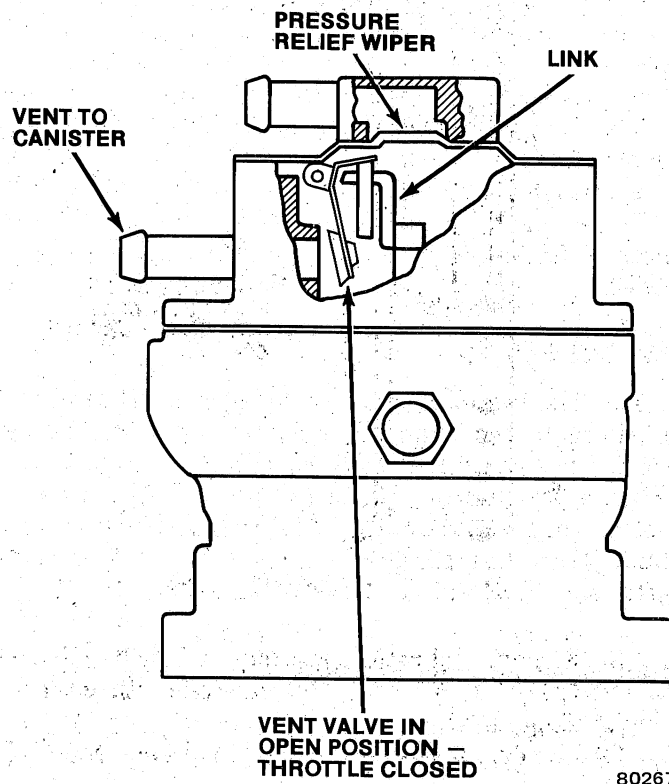

Fig. 1J-11 External Bowl Vent—Typical

Fuel Vapor Control Integrity Test

NOTE: This procedure is for six- and eight-cylinder engines only.

(1) If a manometer is not available, one may be fabricated (fig. 1J-12).

(a) Attach a 6-foot length of 3/8-inch clear plastic tubing (Tygon or equivalent) to a 4-foot x 6-inch x 1-inch board.

(b) Fill tube with water to a height of 15 inches.

(2) Visually inspect fuel vapor control system for loose or damaged hoses, clamps, etc. Repair as necessary.

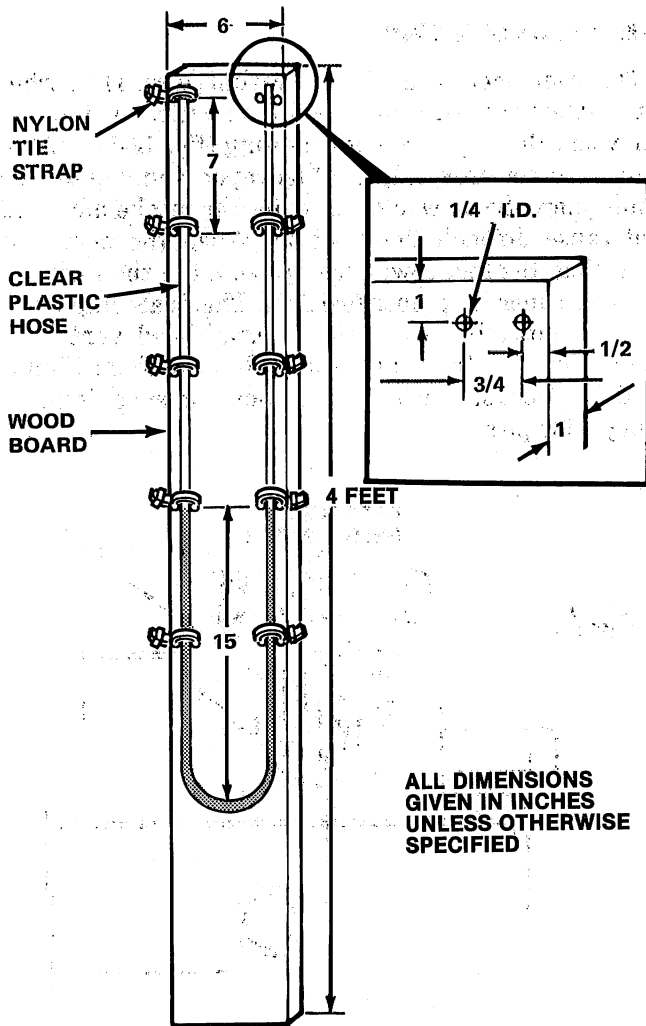

Fig. 1J-12 Fabricated Manometer

90566

(3) Remove fuel return hose (six- and eight-cylinder engines only) from fuel filter (engine compartment) and plug opening in filter.

(4) Remove fuel tank vapor hose from charcoal canister.

(5) Connect plastic tube or rubber hose between manometer and fuel tank vapor hose.

NOTE: Fuel tank must be no more than 3/4 full.

CAUTION: Do not pressurize the fuel vapor control system more than 1.5 psi or 10.3 kPa (4.15 inches of water).

(6) With bicycle tire air pump (suggested maximum pump size is 15 inches in length, 1 inch plunger diameter), pressurize system at fuel return hose until column of water in manometer rises 15 inches (1.1 in. Hg or 3.7 kPa) from no-pressure position.

(7) With soap and water solution, inspect all fuel vapor control system connections for leaks (bubbles). Repair as necessary.

(8) Connect fuel tank vapor hose to canister and fuel return hose to fuel filter.

FUEL RETURN SYSTEM

All Jeep vehicles with six- and eight-cylinder engines employ a fuel return system to reduce the possibility of high temperature fuel vapor problems. The fuel return system is comprised of a fuel filter with a return nipple and a return line to the fuel tank (fig. 1J-13).

The fuel return line is routed to the fuel tank, where it connects to a nipple on the fuel tank sending unit. During normal operation, a small portion of liquid fuel is returned to the tank. During periods of high under hood temperatures, vaporized fuel is also returned to the tank and not passed to the carburetor.

The return line nipple on the fuel filter must be positioned upward to ensure proper fuel system operation.

Some engine/carburetor combinations are equipped with an inline-check valve in the fuel return system near the fuel filter. The valve eliminates any possibility of fuel returning to the carburetor through the fuel return line. The check valve has a stainless steel, spring-assisted check ball that closes the orifice (fig. 1J-14). The valve is secured by a clamp. Pressure of 0.1 to 0.6 psi (0.68 to 4.13 kPa) at the fuel filter end opens the check valve and permits normal operation of the fuel system.

The check valve is marked with an arrow that indicates the direction of normal fuel flow. If it is reversed, the fuel return system will not function.

FUEL GAUGE

Refer to Chapter 1L—Engine Instrumentation for operation, malfunction diagnosis and replacement procedures. Service of the sending unit is described within Fuel Tank in this chapter.

FUEL PUMP

A single-action, stamped fuel pump is used for all engine applications. The fuel pump is comprised of an actuating lever, a diaphragm and spring, an inlet valve and an outlet valve (fig. 1J-15). An eccentric on the engine camshaft operates the fuel pump lever, which is linked to the pump diaphragm. The lever pulls the diaphragm to its extended position to pump fuel into the inlet valve. Spring pressure pushes the diaphragm toward its relaxed position to force fuel out of the outlet valve. When the carburetor float needle valve closes, fuel pump output is limited to the amount that returns back to the fuel tank through the fuel return line. The fuel accumulated in the fuel pump chamber prevents the diaphragm from relaxing. The actuating lever continues to move up and down, but is prevented from operating the diaphragm, which is held in its extended position by fuel pressure. Fuel flow from the pump remains halted

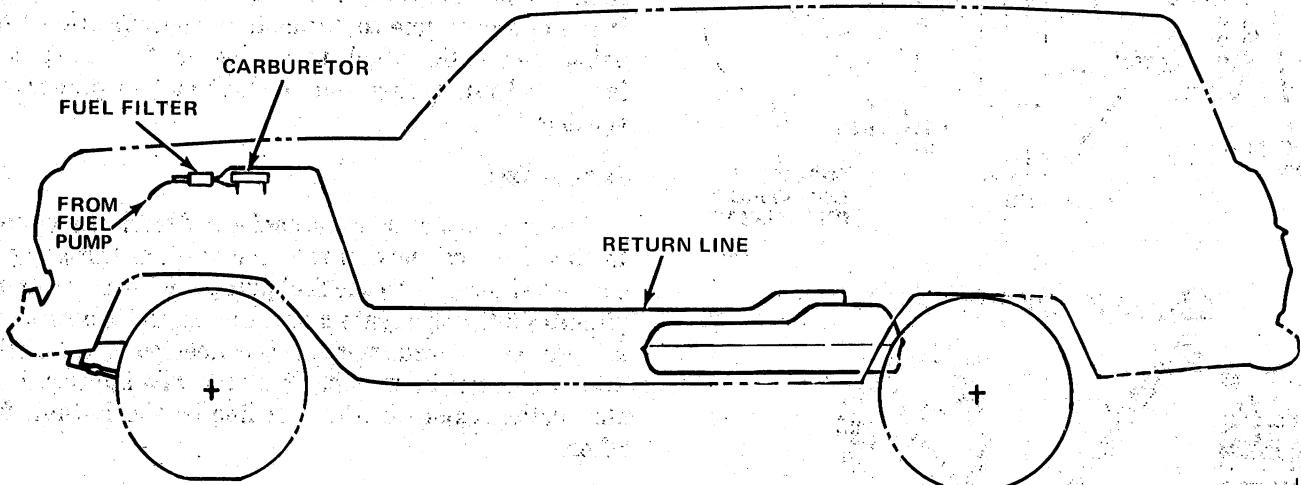
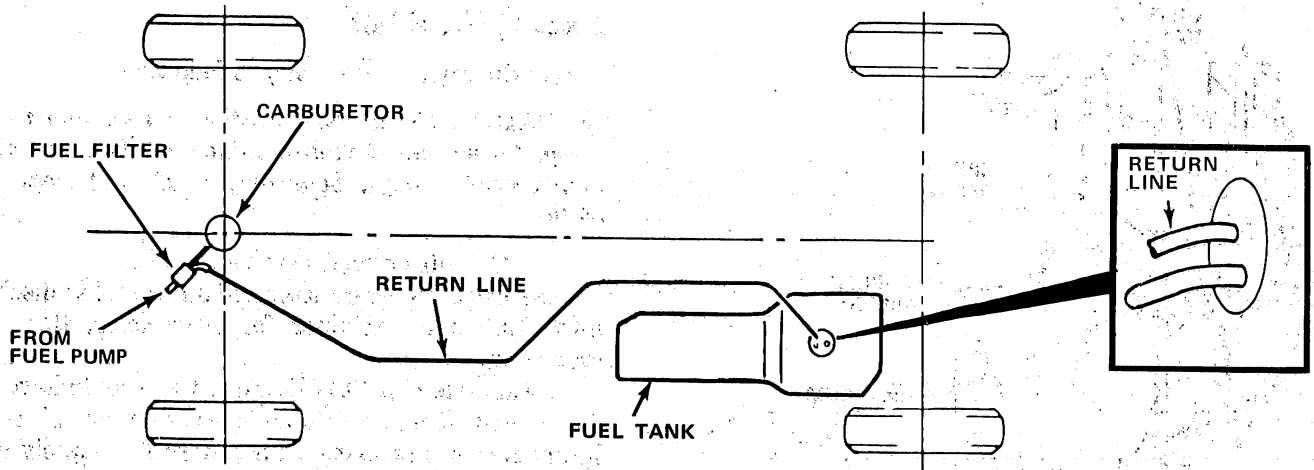
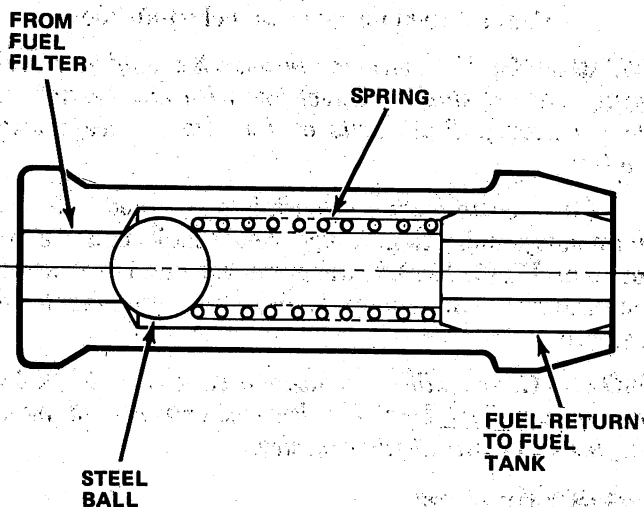

Fig. 1J-13 Fuel Return System—Typical

J43185



60278

Fig. 1J-14 In-Line Check Valve

until excess pressure is released through the fuel return line or the carburetor needle opens. This process continues as long as the engine is operating.

Fuel pumps cannot be overhauled. Replace a fuel pump if it fails any of the following tests.

NOTE: Before performing tests, ensure the in-line fuel filter (six- and eight-cylinder engines) is not clogged.

Pressure Test

- (1) Remove air cleaner assembly.
- (2) Disconnect fuel inlet fitting or fuel filter at carburetor.
- (3) Disconnect fuel return hose at fuel filter and plug nipple on filter.

NOTE: Remove any spilled fuel from engine.

- (4) Connect pressure gauge, restrictor and flexible hose between fuel filter and carburetor (fig. 1J-16).
- (5) Position flexible hose and restrictor so fuel can be discharged into suitable graduated container.

WARNING: Use extreme caution when engine is operating. Do not stand in direct line with fan. Do not put hands near pulleys, belts or fan. Do not wear loose clothing.

- (6) Operate engine at curb idle rpm and discharge fuel into container by momentarily opening hose restrictor.

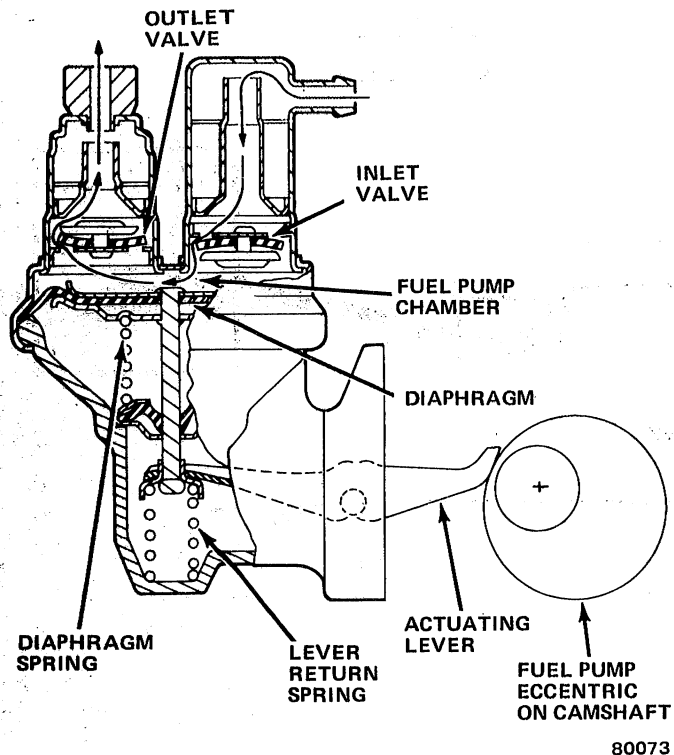

Fig. 1J-15 Fuel Pump—Typical

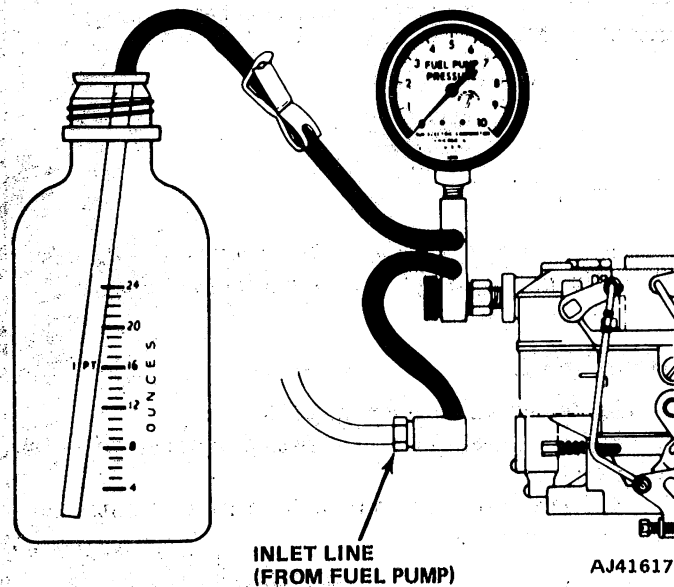

Fig. 1J-16 Fuel Pump Pressure and Volume Test

(7) Close hose restrictor, allow pressure to stabilize, and note pressure. Gauge should indicate 6.5 to 8 psi (45 to 55 kPa) for four-cylinder engines, 4 to 5 psi (28 to 34 kPa) for six-cylinder engines, and 5 to 6.5 psi (34 to 45 kPa) for eight-cylinder engines.

If the pump pressure is not within specification and the fuel lines and filter are in satisfactory condition, the pump is defective and should be replaced. If the pump pressure is within specification, perform the capacity and vacuum tests.

Capacity (Volume) Test

Test the capacity (volume) as follows:

WARNING: Use extreme caution when engine is operating. Do not stand in direct line with fan. Do not put hands near pulleys, belts or fan. Do not wear loose clothing.

- (1) Operate engine at curb idle rpm.
- (2) Open hose restrictor and allow fuel to discharge into graduated container for 30 seconds, then close restrictor.

At least one pint (0.47 liters) of fuel should have been discharged. If pump volume is less than one pint, (0.47 liters) repeat test using an auxiliary fuel supply and a replacement fuel filter (six- and eight-cylinder engines). If the pump volume conforms to the specification while using the auxiliary fuel supply, inspect for a restriction in the fuel supply line from the tank and for proper tank venting.

Vacuum Tests

Two vacuum tests can be performed on the fuel pump. In the direct connection test, the vacuum test gauge is connected directly to the fuel pump inlet. This tests the pump's ability to create a vacuum. In the indirect connection test, a vacuum gauge is connected by a T-fitting into the pump inlet line. This test will indicate if an obstruction exists in the fuel line or the in-tank fuel filter.

Direct Connection Test

- (1) Disconnect fuel inlet pipe at fuel pump.
- (2) Connect vacuum gauge to fuel pump inlet.

WARNING: Use extreme caution when engine is operating. Do not stand in direct line with fan. Do not put hands near pulleys, belts or fan. Do not wear loose clothing.

- (3) Operate engine at curb idle rpm and note vacuum gauge indication. Gauge should indicate a vacuum of 10 in. Hg (34 kPa). If the pump vacuum is not within specification, the pump is defective and should be replaced.

NOTE: Gauge will not indicate a vacuum until fuel in carburetor float bowl has been consumed and pump begins to operate at full capacity.

Indirect Connection Test

- (1) Disconnect fuel inlet pipe at fuel pump.
- (2) Install T-fitting between disconnected fitting and fuel pump inlet. Connect vacuum gauge to T-fitting.

WARNING: Use extreme caution when engine is operating. Do not stand in direct line with fan. Do not put hands near pulleys, belts or fan. Do not wear loose clothing.

(3) Operate engine at 1500 rpm for 30 seconds. Vacuum should not exceed 3 in. Hg (10 kPa).

(4) If vacuum exceeds 3 inches of mercury, check fuel line for restriction. A partially clogged in-tank fuel filter can also cause excess vacuum.

NOTE: Gauge will not indicate a vacuum until fuel in carburetor float bowl has been consumed and pump begins to operate at full capacity.

Fuel Pump Specification Chart

Engine	Volume (30 seconds)	Pressure PSI (kPa)	Vacuum in. Hg(kPa)	
			Direct	Indirect
Four-Cylinder	1 pint (0.47 liters)	6.5 to 8 (44 to 55)	10 (33.77kPa)	3 (10.13kPa)
Six-Cylinder	1 pint (0.47 liters)	4 to 5 (28.58 to 34.47)	10 (33.77kPa)	3 (10.13kPa)
Eight-Cylinder	1 pint (0.47 liters)	5 to 6.5 (34 to 45)	10 (33.77kPa)	3 (10.13kPa)

80262B

Fuel Pump Replacement

Removal

- (1) Disconnect fuel pipe fittings from fuel pump.
- (2) Remove retaining screws.
- (3) Remove pump and gasket.

Installation

- (1) Install pump and replacement gasket.

NOTE: Ensure actuating lever is positioned properly on camshaft eccentric.

- (2) Install retaining screws.
- (3) Connect fuel pipe fittings to fuel pump.

FUEL ECONOMY TESTS

When testing fuel economy for six- and eight-cylinder engines, connect the testing device between the fuel filter and the carburetor. Do not block off the fuel return line because this may cause an erroneous miles-per-gallon indication.

SPECIFICATIONS

Fuel Tank Capacity

Vehicle	Gallons
CJ	14.8 (56.0 liters) Optional: 20 (75.6 liters)
Cherokee Wagoneer	21.5 (81.4 liters)
Truck	18.2 (68.9 liters)

80708

CARBURETOR MODEL 2SE – 2 VENTURI

	Page
Carburetor Circuits	1J-13
Carburetor Overhaul	1J-16
Carburetor Replacement	1J-16
Choke Mechanism Service	1J-29

	Page
General	1J-11
Sealed Idle Mixture Screw	1J-16
Service Adjustment Procedures	1J-25
Specifications	1J-30

GENERAL

The model 2SE carburetor is a two venturi, two stage, down draft type carburetor (figs. 1J-17 and 1J-18). To reduce weight, aluminum castings are used for the air horn, float bowl and throttle body. A heat insulator gasket is located between the throttle body and float bowl to reduce heat transfer to the float bowl.

The primary stage has a triple venturi with a small 35 mm bore that provides efficient fuel metering control during idle and partial throttle operation.

The secondary stage has a larger 46 mm bore that provides the additional air supply necessary for higher engine power requirements. An air valve with a single tapered metering rod is used in the secondary stage.

An integral one-inch pleated-paper fuel filter with check valve is located between the front of the float bowl and the fuel inlet fitting. The check valve prevents fuel flow to the carburetor in the event of vehicle rollover.

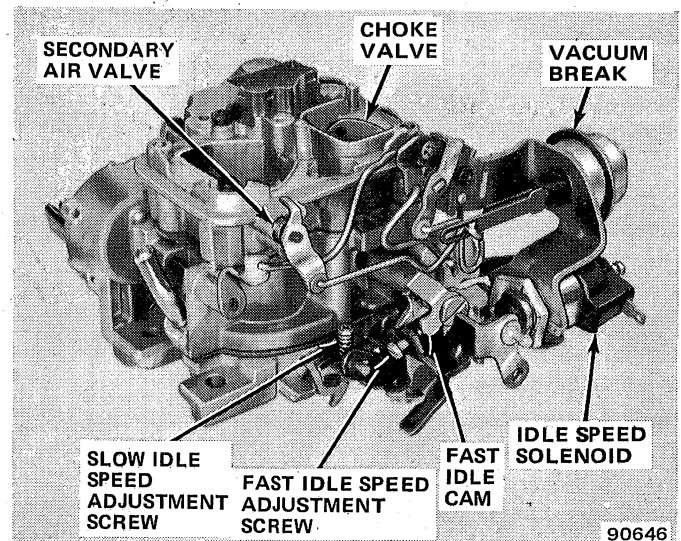

90646

Fig. 1J-17 Model 2SE Carburetor

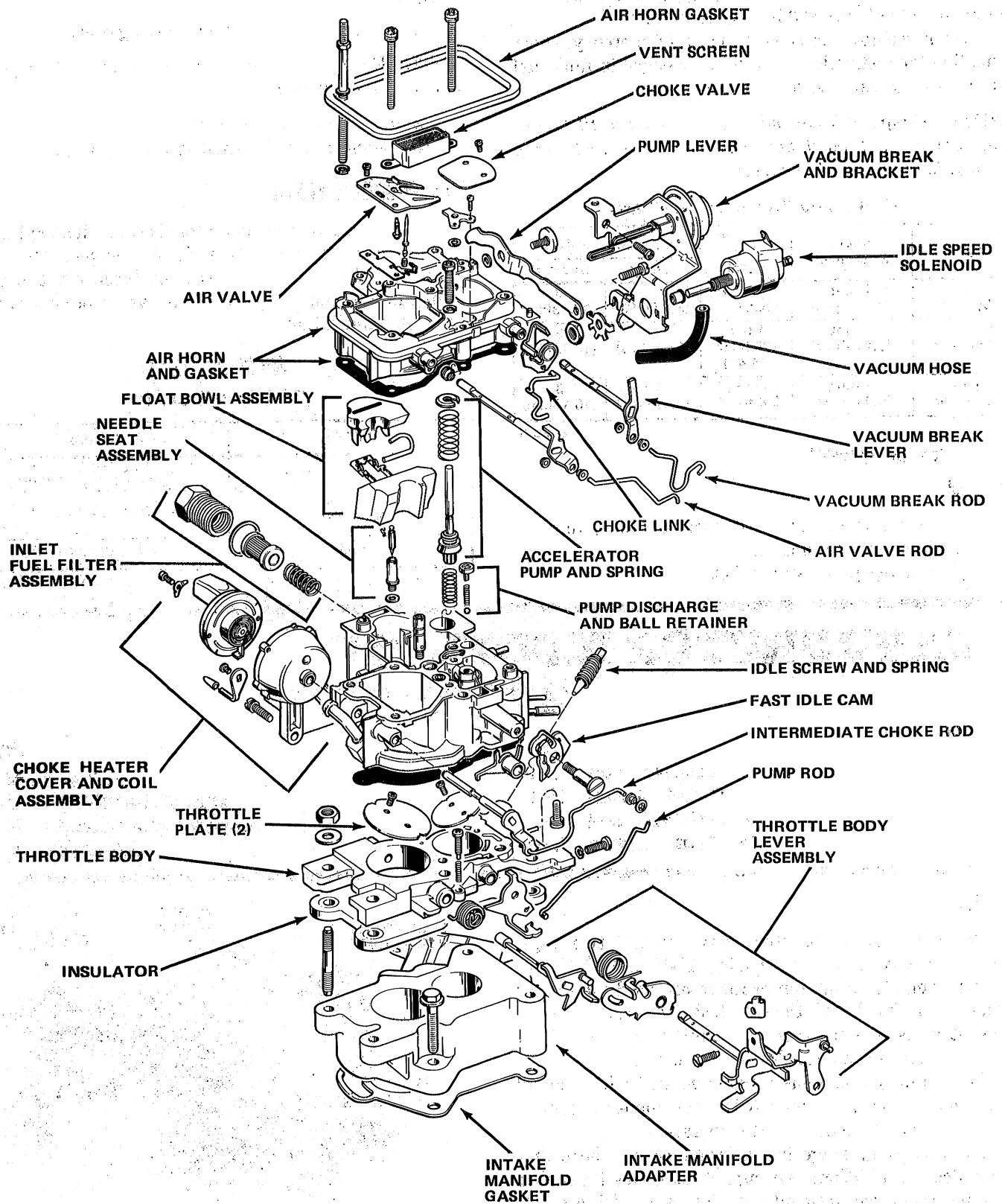

Fig. 1J-18 Model 2SE Carburetor—Exploded View

Identification

The carburetor model identification is stamped vertically on the float bowl in a flat area adjacent to the vacuum tube (fig. 1J-19). When replacing the float bowl, follow the manufacturer's instructions contained in the service package and ensure that the identification number is transferred to the new float bowl.

Refer to the part number on the bowl when servicing the carburetor.

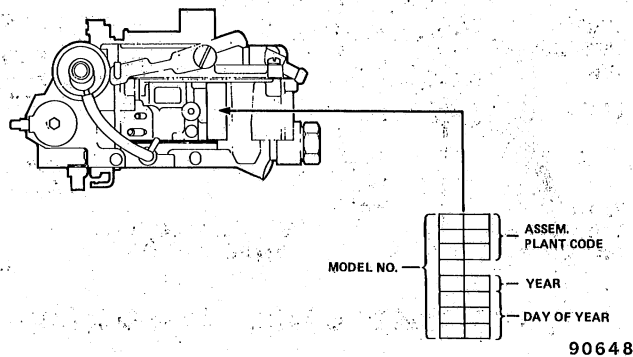

Fig. 1J-19 Model 2SE Carburetor Identification

CARBURETOR CIRCUITS

Model 2SE carburetor has six basic circuits. They are:

- Float
- Idle
- Main Metering
- Power Enrichment
- Pump
- Choke

Float Circuit

The float chamber is located adjacent to the primary and secondary bores (figs. 1J-20 and 1J-21). This feature assures adequate fuel supply to both carburetor venturi bores during all standard engine operations.

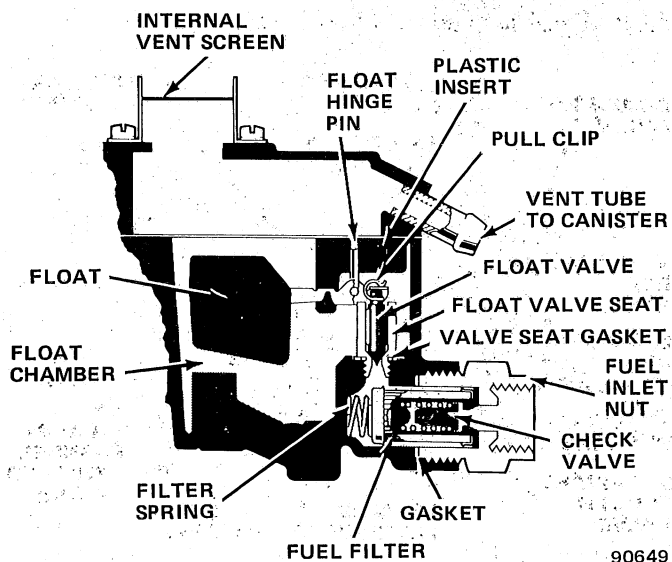

Fig. 1J-20 Model 2SE Carburetor—Float Circuit

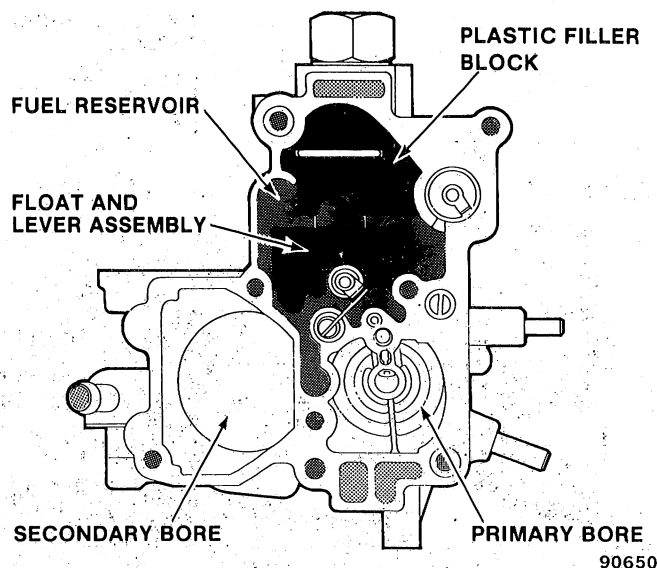

Fig. 1J-21 Model 2SE Carburetor—Fuel Reservoir

A single pontoon-float, brass needle seat, and a rubber tipped float needle with pull clip are used to control the fuel level in the float chamber. The float chamber is internally vented through a vertical vent cavity in the air horn. Above this vent cavity is a removable vent stack assembly that has a small meshed screen at its top. This vent stack provides the correct height for the internal vent.

The float chamber is also externally vented through a tube (fig. 1J-18) in the air horn. A hose connects this tube directly to a vacuum operated vapor vent valve located at the vapor canister. When the engine is not operating, the canister vapor vent valve is open, allowing fuel vapor from the float chamber to flow into the canister where it is stored until purged. The venting of fuel vapor from the carburetor float bowl to the canister conforms to evaporative emission requirements and improves hot engine starting.

Idle Circuit

Fuel for engine idle and partial throttle operation is controlled by the idle circuit. Fuel flows through the main metering jet into the idle tube and continues to and through the idle cross-over passage where it is mixed with air entering from the lower idle air bleed (fig. 1J-22).

A partial throttle adjustment screw in the float bowl aids in refinement of the fuel mixture for good emission control. This screw is **preset** during factory assembly and a plug is installed to prevent indiscriminate tampering and to seal against any fuel leaks. The plug should not be removed nor the screw adjusted during normal service. If it becomes necessary to replace the float bowl, the new service float bowl will include an adjustable partial throttle (APT) screw that has been preset and plugged as required.

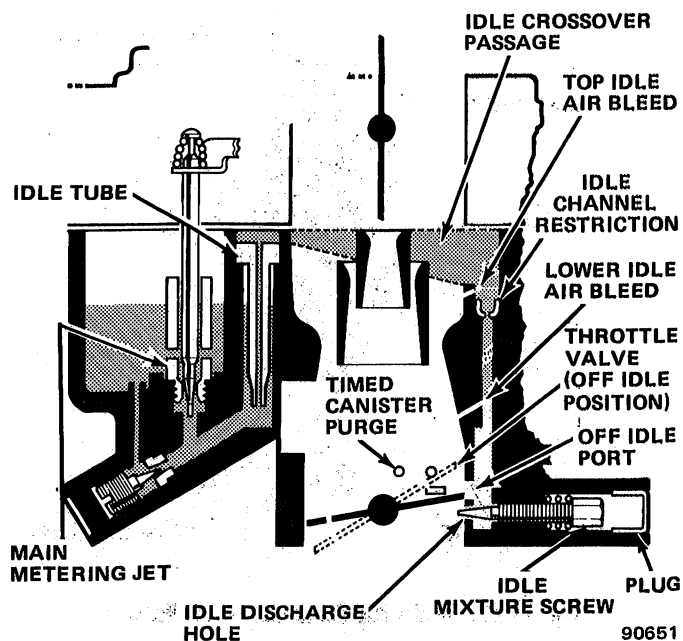

Fig. 1J-22 Model 2SE Carburetor—Idle Circuit

A hot idle compensator assembly (when used) is located in the air horn casting. The opening and closing of the hot idle compensator valve is controlled by a bimetallic strip that is calibrated for a specific temperature. When the valve opens, additional air is allowed to bypass the throttle valves and enter the intake manifold to prevent rough idle during periods of hot engine operation.

The idle mixture screw is recessed in the throttle body casting and sealed with a hardened steel plug to discourage indiscriminate tampering with the factory adjusted mixture setting, which could cause excessive undesirable exhaust emissions. The plug must not be removed, nor the idle mixture screw readjusted, unless required because of major carburetor overhaul or throttle body replacement. Adjustment requires special service procedures.

Main Metering Circuit

At partial throttle and cruising rpm, increased airflow creates a low pressure area in the venturi. Because air above the fuel level in the bowl is at normal pressure, fuel flows to the lower pressure area created by the venturi and amplified by the booster venturi.

The fuel flow moves through the main jets to the main well. Air enters through the main well air bleeds. The resulting mixture of fuel and air is lighter than raw fuel, responds more quickly to changes in venturi vacuum, and is more readily vaporized when discharged into the venturi (fig. 1J-23).

Power Enrichment Circuit

During heavy load or high speed operation the air/fuel ratio must be enriched to provide the necessary increase in engine power.

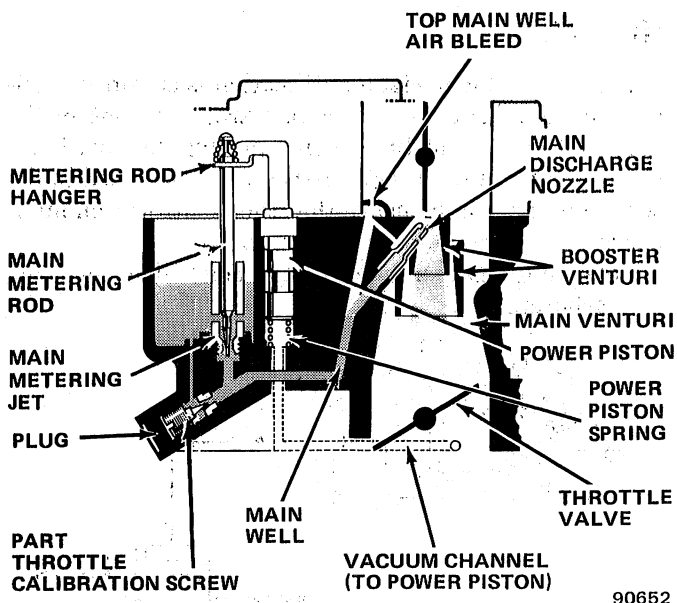

Fig. 1J-23 Model 2SE Carburetor—Main Metering Circuit

Power enrichment is accomplished by means of a calibrated metering rod yoked to a single manifold vacuum actuated piston (fig. 1J-24).

The metering rod piston rests on a calibrated spring that functions to maintain the piston at the top of its cylinder. This allows only the smallest diameter of the tapered metering rods to extend into the main metering jets and permits maximum fuel flow through the jets to the main well cavities.

At idle, partial throttle or cruise conditions, when manifold vacuum is high, the piston is forced down into the vacuum cylinder against the calibrated spring tension and the larger diameters of the metering rods extend into the main metering jets. This restricts the fuel flow to the main well cavities. An additional control is provided by the rod lifter on the accelerator pump rod. This establishes a direct relationship between the metering rod position and the throttle valve opening.

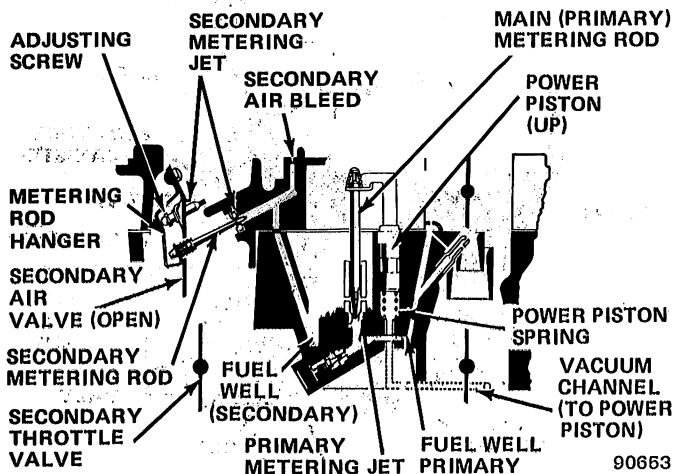

Fig. 1J-24 Model 2SE Carburetor—Power Enrichment Circuit

Pump Circuit

When the throttle is opened suddenly, airflow response through the carburetor is almost immediate. There is a brief time lag before fuel inertia is overcome. This lag causes the desired air/fuel ratio to be leaned out.

A piston-type accelerating pump assembly mechanically supplies the fuel necessary to overcome this deficiency (fig. 1J-25). Fuel is forced into the pump cylinder from the fuel bowl past the pump piston on the upward movement of the accelerator pump shaft. As the throttle lever is moved, the pump link, operating through a system of levers and assisted by the pump drive spring,

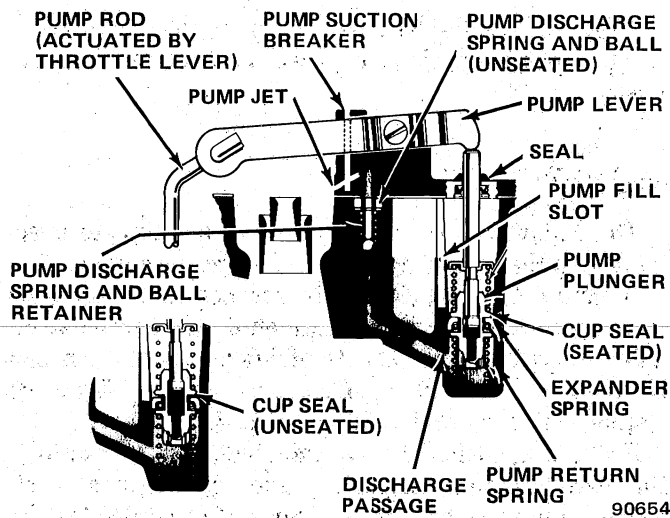

Fig. 1J-25 Model 2SE Carburetor—Pump Circuit

pushes the pump piston down. Fuel is forced through a passage, past the pump discharge check ball, and out the pump discharge jets in the venturi cluster.

Choke Circuit

The choke valve, located in the air horn assembly, provides a high vacuum, both above and below the throttle valves, when it is closed. During engine starting, vacuum above the throttle valve causes fuel to flow from the main metering and idle circuits and provides the richer air/fuel mixture ratio needed for cold engine starting (fig. 1J-26).

The choke shaft is connected by linkage to a bimetallic coil located within the choke cover. This coil winds up (contracts) when cold and unwinds (expands) when heated. When cold, the tension of the coil holds the choke valve closed. When the engine starts, manifold vacuum is applied to the diaphragm assembly to open the choke valve slightly. This is referred to as the initial choke valve clearance.

The carburetor has an adjustment screw located in the primary throttle lever for fast idle speed adjustment. A separate adjustment screw, located in the throttle body, is used to adjust the curb, or base (depending upon application), idle speed (solenoid de-energized).

NOTE: Special rivets and conventional retainers are used to maintain the factory adjustment of the bimetallic choke coil. They provide a tamper-resistant enclosure to discourage indiscriminate readjustment in the field.

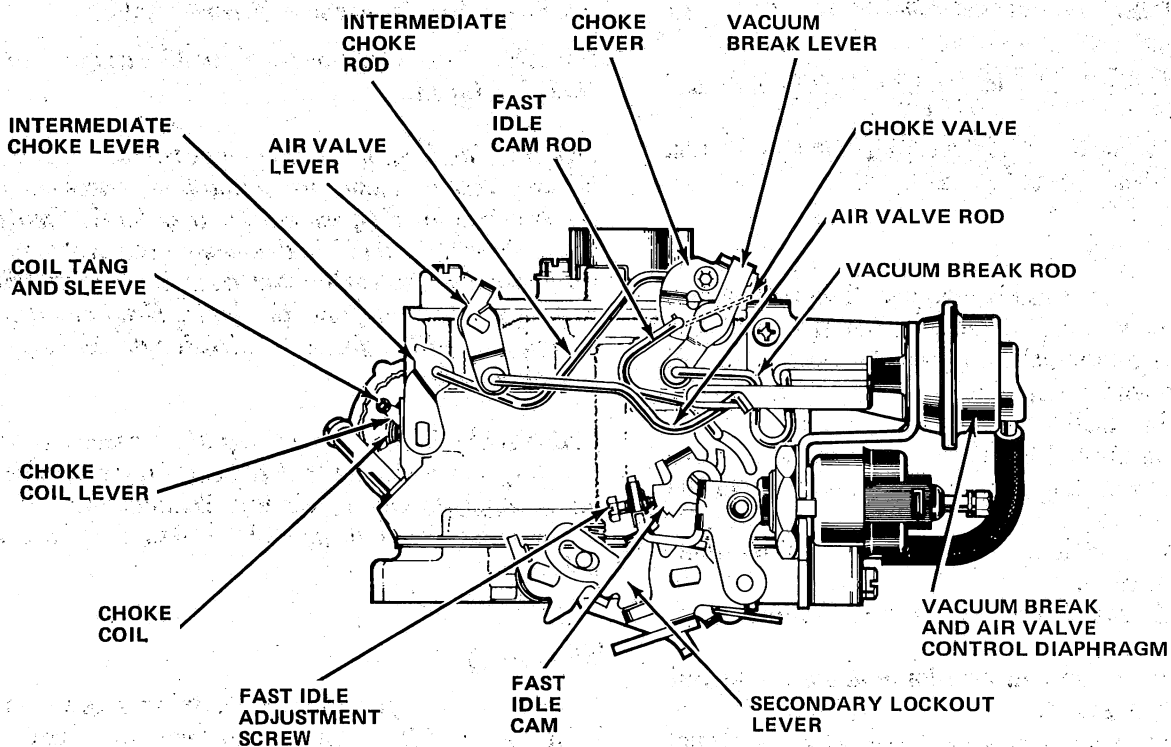

Fig. 1J-26 Model 2SE Carburetor—Choke Circuit

SEALED IDLE MIXTURE SCREW

The idle mixture screw is recessed in the throttle body and sealed with a hardened steel plug to prevent changing the factory assembly adjustment of the air/fuel mixture ratio. **Do not remove the plug and readjust the idle mixture screw unless involved in a major carburetor overhaul, throttle body replacement or the presence of high idle CO has been determined by a competent authority.**

CARBURETOR REPLACEMENT

Removal

Flooding, hesitation on acceleration and other performance complaints are, in many instances, caused by the presence of dirt, water or other foreign matter in the carburetor. To aid in diagnosis, the carburetor should be carefully removed from the engine without draining fuel from the bowl. The contents of the fuel bowl can then be examined for contamination as the carburetor is disassembled. Also, the filter should be examined to determine if it should be replaced.

WARNING: *Battery negative cable must be removed to prevent a potential fire hazard when the fuel pipe fitting is disconnected.*

- (1) Remove battery negative cable.
- (2) Remove vacuum hoses, air cleaner and gasket.
- (3) Disconnect fuel pipe fitting and vacuum hoses from carburetor.

NOTE: *Identify and tag vacuum hoses before disconnecting them.*

(4) Disconnect throttle linkage and electrical connectors.

(5) Remove carburetor attaching bolts and nuts, and remove carburetor and gasket.

Installation

Fill the carburetor bowl before installing carburetor. This reduces the strain on the battery and the possibility of backfire when attempting to start the engine. A small quantity of no-lead fuel will also allow a pre-test of the operation of the float and inlet needle and seat assembly. Operate the throttle lever several times and observe the discharge from the pump jets before installing the carburetor.

- (1) Ensure throttle body and intake manifold mating surfaces are clean.
- (2) Install manifold gasket on replacement carburetor.
- (3) Place carburetor in position and loosely install attaching bolts and nuts.
- (4) Connect vacuum hoses and loosely connect fuel pipe fitting.

(5) Tighten attaching bolts and nuts with 12 foot-pounds (16 N•m) torque.

(6) Tighten fuel pipe fitting with 25 foot-pounds (34 N•m) torque.

(7) Connect throttle linkage and electrical connectors.

(8) Connect battery negative cable.

NOTE: *Plug disconnected vacuum hoses.*

WARNING: *Use extreme caution when engine is operating. Do not stand in direct line with fan. Do not put hands near pulleys, belts or fan. Do not wear loose clothing.*

(9) Adjust idle speed rpm. Refer to Specifications.

(10) Install air cleaner, gasket and connect vacuum hoses.

CARBURETOR OVERHAUL

The following procedures apply to a complete overhaul with the carburetor removed from the engine.

A complete disassembly is not necessary for performing routine service adjustments. Also, in most instances, service adjustments of individual circuits can be completed without removing the carburetor from the engine. Refer to Service Adjustment Procedures.

A complete carburetor overhaul includes disassembly, thorough cleaning, inspection and replacement of all gaskets and worn or damaged parts. It also includes idle speed adjustment, idle mixture adjustment (if removal of adjustment screws was necessary) and fast idle adjustment after the carburetor is reinstalled.

NOTE: *When using an overhaul kit, use all parts included in the kit.*

NOTE: *Flooding, hesitation on acceleration, and other performance problems are in many instances caused by the presence of dirt, water, or other foreign matter in the carburetor. To aid in diagnosing the problem, carefully remove the carburetor from the engine without removing the fuel from the bowl. Examine the bowl contents and filter for contamination as the carburetor is disassembled.*

CAUTION: *Before performing any service on the carburetor, it is essential that the carburetor be placed on an appropriate holding fixture. Without the use of the holding fixture, it is possible to damage the throttle valves.*

Disassembly

- (1) Remove pump lever retaining screw from air horn (fig. 1J-27). Rotate pump lever to remove from pump rod.

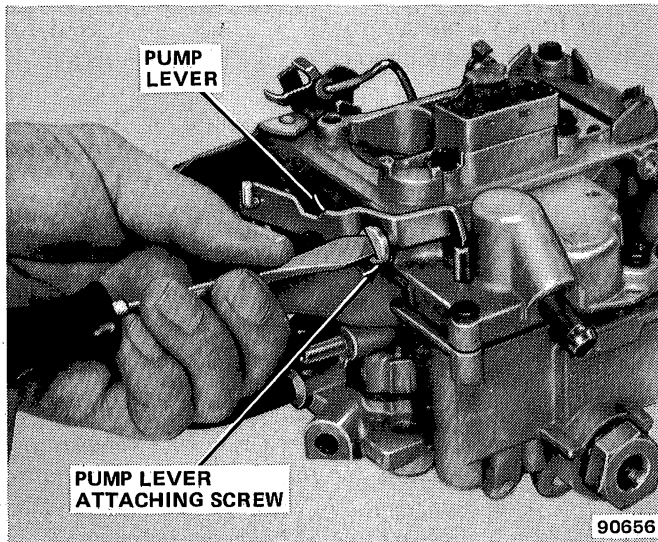

Fig. 1J-27 Model 2SE Carburetor—Pump Lever Removal

- (2) Remove hose from vacuum break assembly.
- (3) Remove idle speed solenoid-vacuum break bracket attaching screws from air horn and throttle body (fig. 1J-28). Rotate bracket to remove vacuum break rod and air valve rod from vacuum break diaphragm plunger and remove bracket assembly from float bowl. If not removed previously, solenoid may be removed from bracket.

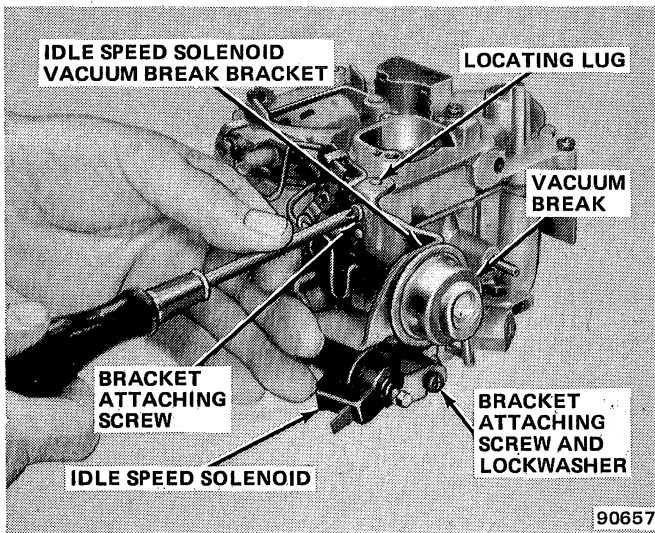

Fig. 1J-28 Model 2SE Carburetor—Vacuum Break Removal

CAUTION: Do not immerse vacuum break assembly and solenoid in carburetor cleaning solution.

- (4) Remove and discard retaining clip from intermediate choke rod at choke lever (fig. 1J-29). A new retaining clip is required for reassembly. Remove choke rod and plastic bushing from choke lever.

The plastic bushing will be loose and should be retained for reassembly.

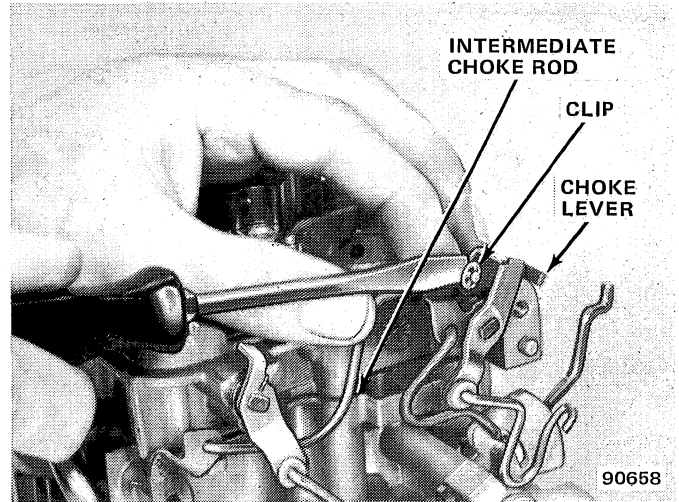

Fig. 1J-29 Model 2SE Carburetor—Choke Rod Removal

- (5) If equipped, remove two small screws that retain hot idle compensator valve (fig. 1J-30). Remove valve and seal from air horn, discard seal. Hot idle compensator valve must be removed to gain access to short air horn-to-bowl attaching screw.

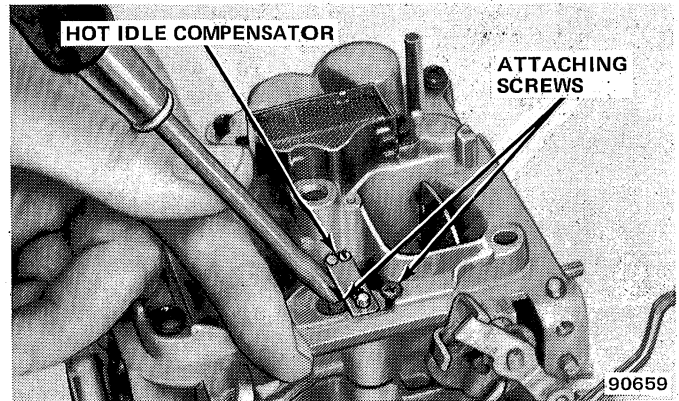

Fig. 1J-30 Model 2SE Carburetor—Idle Compensator Removal

- (6) Remove six air horn-to-bowl attaching screws and lockwashers (fig. 1J-31). Remove vent and screen assembly.

- (7) Rotate fast idle cam to full UP position and remove air horn assembly by tilting to disengage fast idle cam rod from slot in fast idle cam (fig. 1J-32).

NOTE: DO NOT remove fast idle cam and screw from float bowl. These components are not serviced separately and must remain permanently in place as installed during manufacturing assembly. The new service replacement float bowl will include the secondary lock-out lever, fast idle cam and screw installed as required.

- (8) Further disassembly of the air horn is not required for cleaning purposes. If component replacement is required, remove staking on two choke valve attaching screws. Remove screws, choke valve and shaft from air horn.

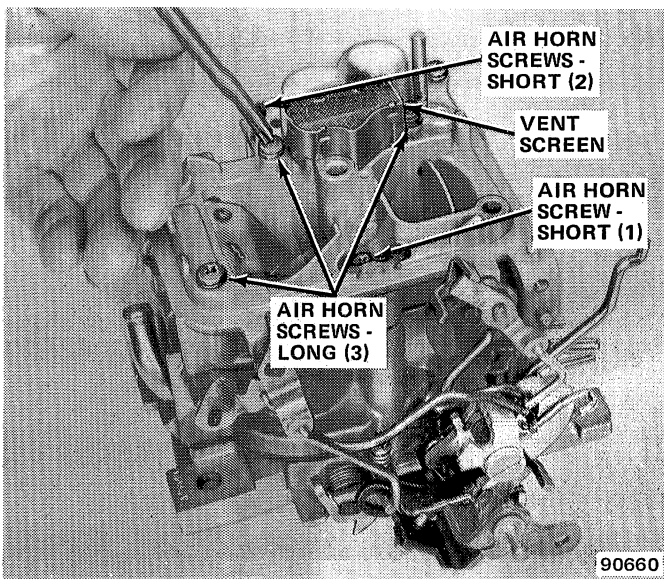

**Fig. 1J-31 Model 2SE Carburetor—
Air Horn Attaching Screws and Vent Screen**

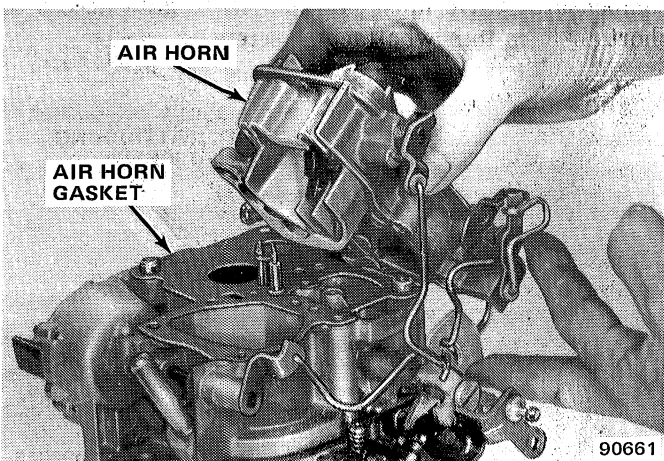

Fig. 1J-32 Model 2SE Carburetor—Air Horn Removal

NOTE: The air valve screws are permanently staked in place and should not be removed. Do not attempt to remove the secondary metering rod from the air valve assembly. The secondary metering rod adjustment screw is preset during original assembly. Do not attempt to change this adjustment in the field. If air horn replacement is required during carburetor service, the new service air horn will include a preadjusted secondary metering rod-air valve assembly. It is not necessary to remove the vacuum break rod, fast idle cam rod or air valve rod from the levers in the air horn unless replacement of the rods is necessary. The plastic bushings used with the levers can be cleaned with carburetor cleaning solution.

(9) If necessary to replace vacuum break rod, fast idle cam rod or air valve rod, remove retaining clips from end of rods. Remove plastic bushing on rods and retain for reassembly.

(10) Remove air horn gasket. Gasket is pre-cut for easy removal around metering rod and hanger assembly (fig. 1J-33).

(11) Remove pump plunger from pump well.

(12) Remove pump return spring from pump well.

(13) Remove plastic filler block over float valve.

(14) Remove float assembly and float needle by pulling up on retaining pin. Remove inlet needle seat and gasket with Seat Remover J-22769 (fig. 1J-34).

(15) Remove power piston and metering rod assembly by depressing piston stem and allowing it to snap free (fig. 1J-35).

NOTE: The power piston, when equipped, can be easily removed by pressing the piston down and releasing it with a snap. This will cause the power piston spring to snap the piston up against the plastic retainer. This procedure may have to be repeated several times.

CAUTION: Do not remove power piston by using pliers on metering rod holder. Remove the power piston spring from the piston bore. If necessary, metering rod can be removed from power piston hanger by compressing spring on top of metering rod and aligning groove on rod with slot in holder (fig. 1J-36). Use extreme care in handling the metering rod to prevent damage to metering rod tip.

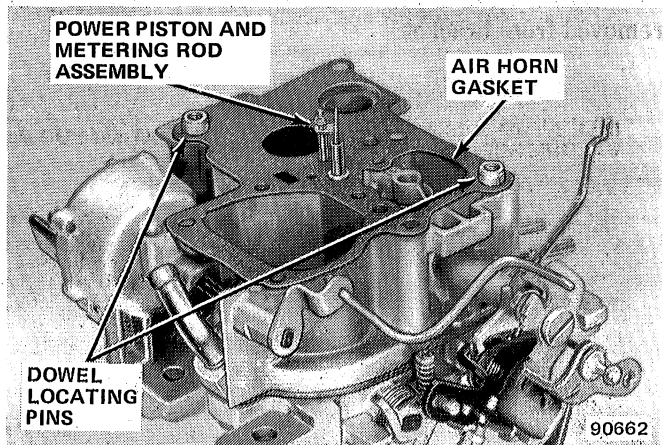

Fig. 1J-33 Model 2SE Carburetor—Float Bowl Disassembly

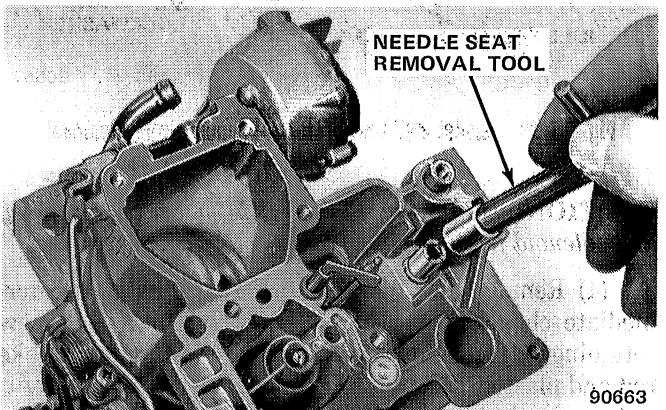

Fig. 1J-34 Model 2SE Carburetor—Inlet Needle Seat Removal

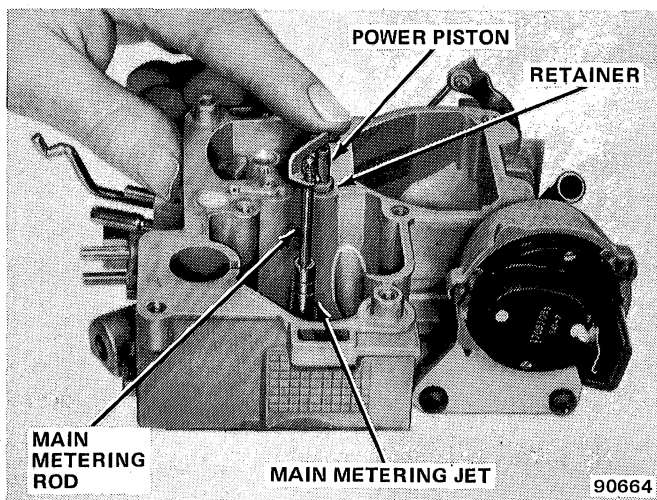

Fig. 1J-35 Model 2SE Carburetor—Power Piston Removal

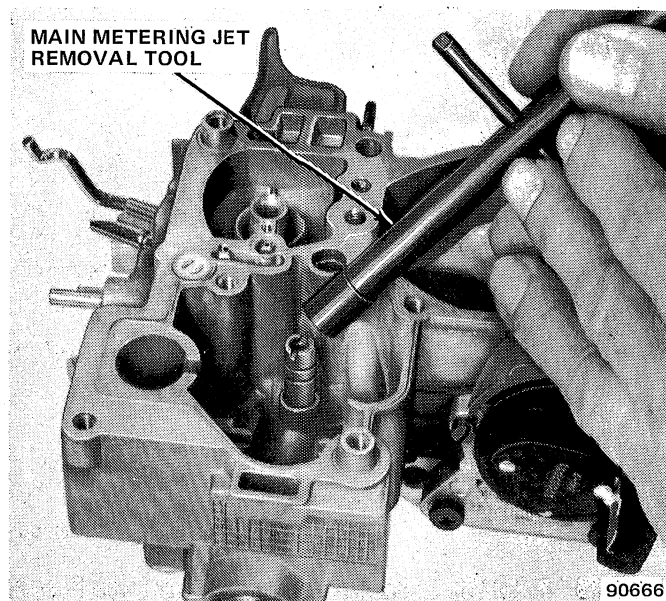

Fig. 1J-37 Model 2SE Carburetor—Main Metering Jet Removal

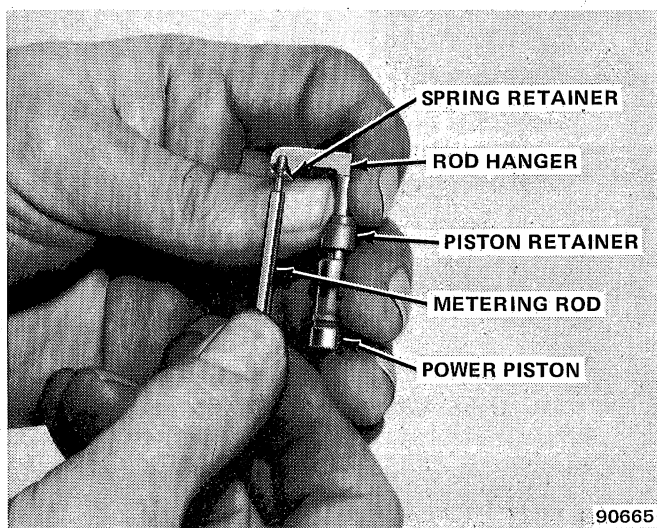

Fig. 1J-36 Model 2SE Carburetor—
Removing Metering Rod from Piston Holder

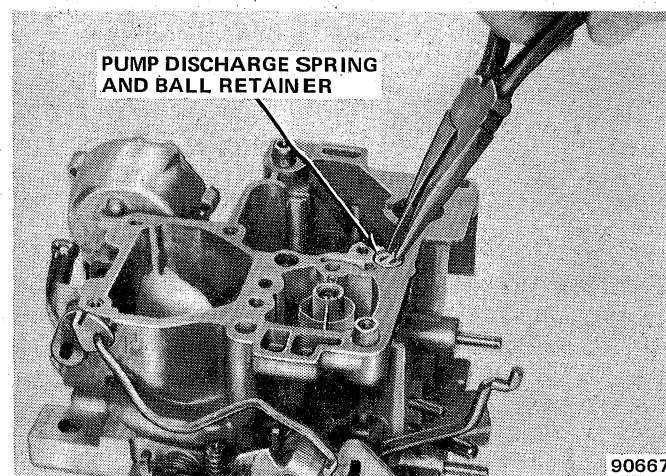

Fig. 1J-38 Model 2SE Carburetor—Pump Discharge Retainer Removal

(16) Remove main metering jet with Tool J-22769 or suitable screwdriver. Screwdriver must fully fit slot in top of jet to prevent damage to jet (fig. 1J-37).

CAUTION: To prevent damage to pump discharge check ball spring, insert ends of needlenose pliers in plastic retainer only far enough to grasp the head of the retainer for removal. Turn bowl upside down and catch pump discharge spring and check ball in palm of hand.

(17) Use needlenose pliers to remove plastic retainer holding pump discharge spring and check ball in place (fig. 1J-38). Discard plastic retainer (a new retainer is required for assembly).

(18) Remove three attaching rivets and retainers from choke cover and coil assembly. Pull straight outward and remove cover and coil assembly from choke housing.

NOTE: The tamper-resistant choke cover design is used to discourage indiscriminate readjustment of the choke cover and coil assembly in the field. However, it is necessary to remove the cover and coil assembly during normal carburetor disassembly for cleaning and overhaul. With a small chisel and hammer carefully cut off each rivet head. Use a small drift and hammer to drive remainder of rivets out of choke housing and remove cover and coil assembly. Use care to prevent damage to choke cover and housing.

(19) Remove screw from end of intermediate choke shaft inside choke housing (fig. 1J-39). Remove choke coil lever from shaft.

(20) Remove intermediate choke shaft and lever assembly from float bowl by sliding rearward out of throttle lever side (fig. 1J-40).

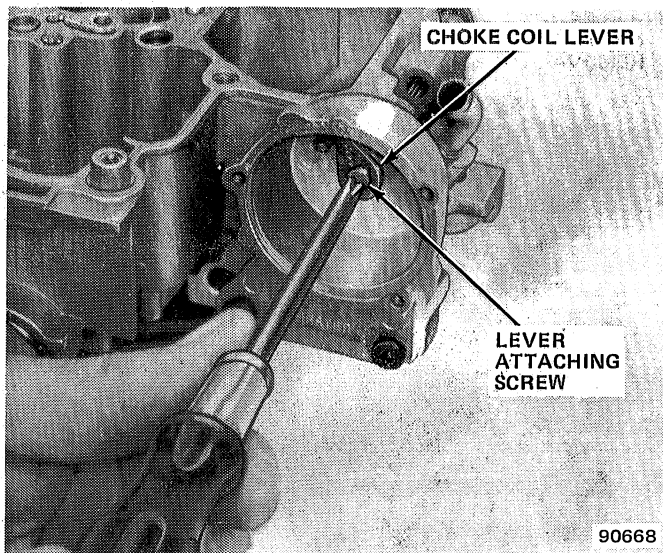

90668

Fig. 1J-39 Model 2SE Carburetor—Choke Coil Lever Screw Removal

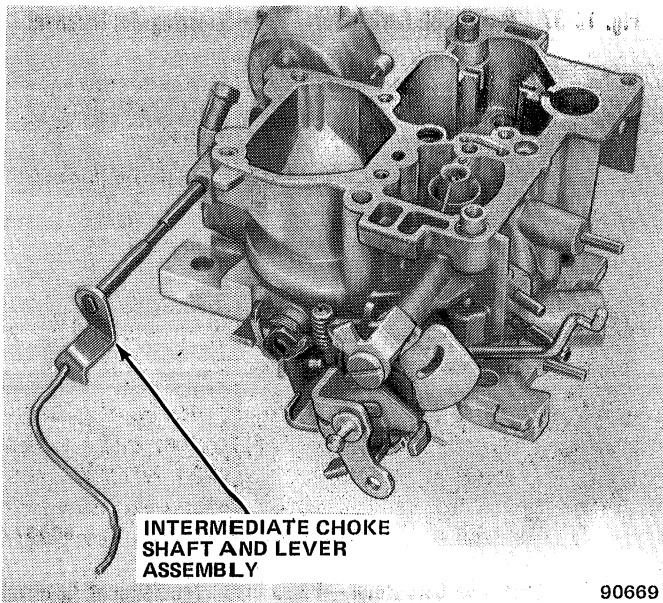

90669

Fig. 1J-40 Model 2SE Carburetor—Intermediate Choke Shaft Removal

(21) Remove choke housing by removing two attaching screws in throttle body (fig. 1J-41).

(22) Remove fuel inlet fitting, gasket, check valve/filter assembly and spring.

(23) Disassemble remaining throttle body components.

(a) Remove four throttle body-to-bowl attaching screws and lockwashers and remove throttle body assembly (fig. 1J-42).

CAUTION: Place throttle body assembly on carburetor holding fixture (Tool J-9789-118) to avoid damaging throttle valves.

(b) Hold primary throttle lever wide-open and disengage pump rod from throttle lever by rotating rod until squirt on rod aligns with slot in lever.

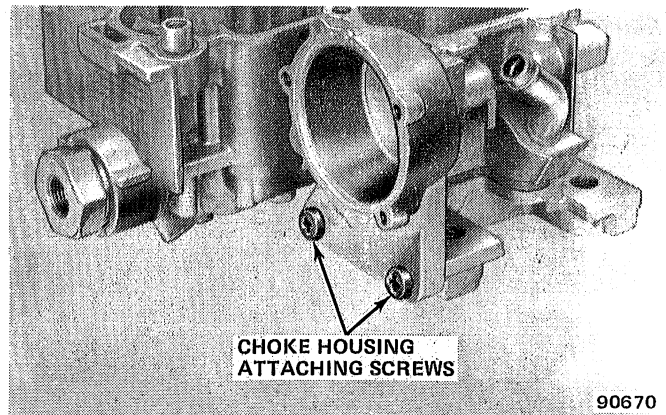

90670

Fig. 1J-41 Model 2SE Carburetor—Choke Housing Screws

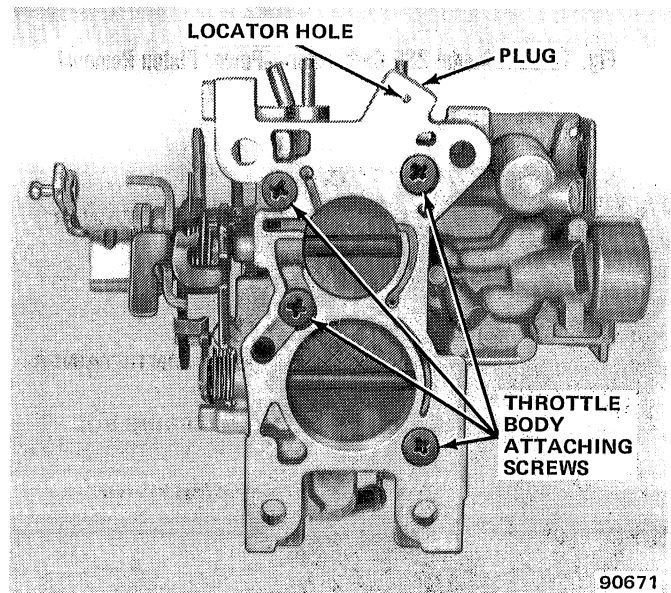

90671

Fig. 1J-42 Model 2SE Carburetor—Throttle Body Screws

(c) If replacement is necessary, remove fast idle screw and clip in primary throttle lever.

(d) If required, remove slow idle speed screw and spring in throttle body. Further disassembly of the throttle body is not required for cleaning purposes (fig. 1J-43).

NOTE: The primary and secondary throttle valve screws are permanently staked in place and must not be removed. The throttle body is serviced as a complete assembly.

NOTE: Do not remove the plug concealing the idle mixture screw unless it is necessary to replace the mixture screw or normal soaking and air pressure fails to clean the idle mixture passages.

CAUTION: The idle mixture should be adjusted only if required at time of major carburetor overhaul, for throttle body replacement or for the presence of high idle carbon monoxide (CO) when determined by authorized competent officials.

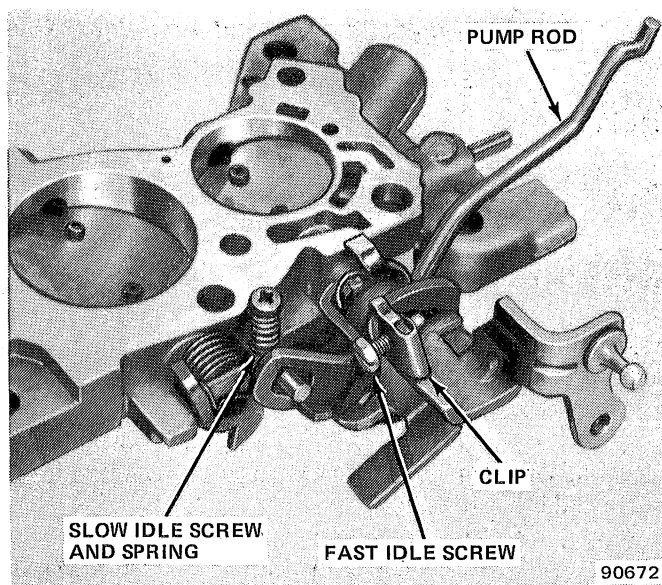

Fig. 1J-43 Model 2SE Carburetor—Throttle Body Assembly

(24) Remove idle mixture screw and plug as follows:

(a) Position punch in locator hole in throttle body beneath idle mixture screw plug (manifold side) (fig. 1J-44). Holding punch vertical, drive punch through locator until hardened steel plug shatters. Holding punch at 45 degree angle, breakout throttle body casting to gain access to mixture screw plug.

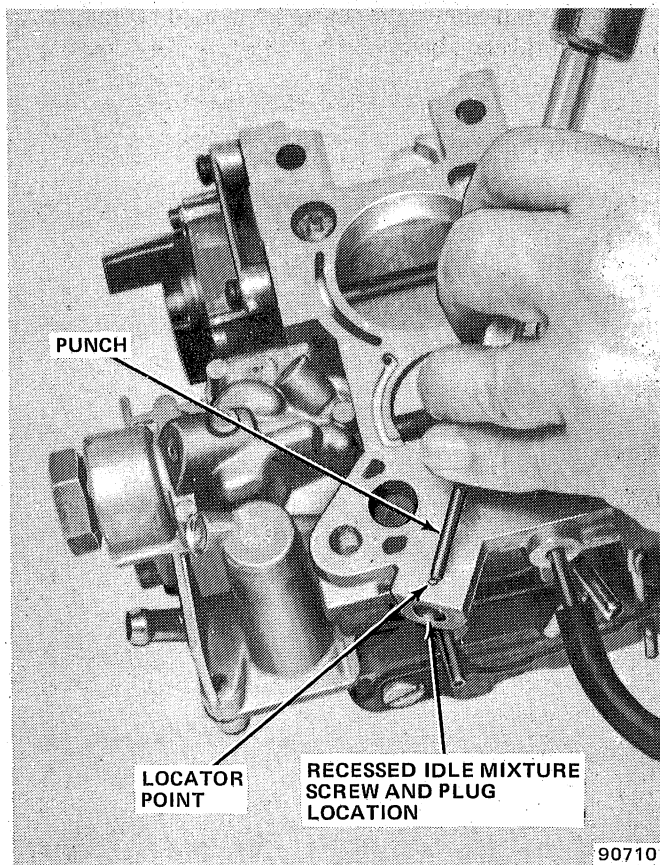

Fig. 1J-44 Model 2SE Carburetor—Idle Mixture Screw Plug Removal

NOTE: Hardened plug will shatter rather than remaining intact. It is not necessary to remove the plug completely; instead, remove loose pieces to allow use of Idle Mixture Adjusting Tool J-29030.

(b) Using Tool J-29030, remove idle mixture screw, washer (if used), and spring from throttle body (fig. 1J-45).

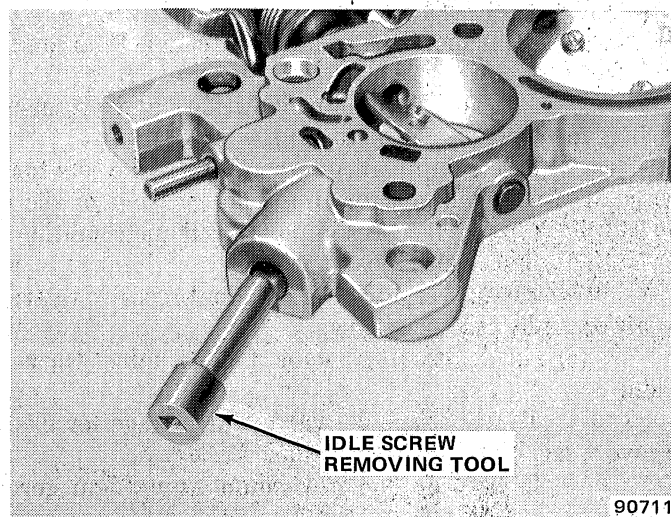

Fig. 1J-45 Model 2SE Carburetor—Idle Mixture Screw Removal

Cleaning and Inspection

The carburetor components should be cleaned in a cold immersion-type carburetor cleaning solution.

CAUTION: The solenoid, choke cover and coil assembly, rubber parts, plastic parts, diaphragms, pump plunger, and plastic filler block should NOT be immersed in carburetor cleaning solution because they will swell, harden or distort. The plastic bushings located at the end of the vacuum break rod, fast idle cam rod and air valve rod can be cleaned with carburetor cleaning solution.

(1) Thoroughly clean all metal parts and blow dry with compressed air. Ensure all fuel passages and metering components are free of burrs and foreign matter. Do not insert drill bits or wires into jets and passages.

(2) Inspect upper and lower surface of carburetor castings for damage.

(3) Inspect holes in levers for excessive wear or out of round conditions. If worn, levers should be replaced. Inspect plastic bushings for damage and excessive wear. Replace as required.

(4) Inspect, repair or replace components if following problems are encountered.

(a) Flooding:

1. Inspect float needle and seat for debris, deep wear grooves, scores and improper seating.

2. Inspect float needle pull clip for proper installation (fig. 1J-46). Use care to prevent bending needle pull clip.

3. Inspect float, float arms and hinge pin for distortion, binding and burrs. Check density of material in float; if heavier than normal, replace float.

4. Clean or replace fuel inlet filter/check valve.

(b) Hesitation:

1. Inspect pump plunger for cracks, scores and excessive cup wear.

2. Inspect pump duration and return springs for weakness or distortion.

3. Examine all pump passages and jets for presence of foreign matter, improper seating of discharge check ball and scores in pump well and condition of pump discharge check ball spring.

4. Inspect pump linkage for excessive wear; repair or replace as necessary.

(c) Hard Starting—Poor Cold Engine Operation:

1. Inspect choke valve and linkage for excessive wear, binding or distortion.

2. Inspect choke vacuum diaphragm for leaks.

3. Clean or replace carburetor fuel inlet filter/check valve.

4. Inspect inlet needle for improper seating, debris, etc. Also examine items listed within Flooding above.

(d) Poor Engine Performance—Poor Gas Mileage:

1. Clean all fuel and vacuum passages in castings.

2. Inspect choke valve for freedom of movement.

3. Examine power piston, metering rod and jet for foreign matter, sticking, binding, damage and excessive wear.

4. Examine air valve and secondary metering rod for binding conditions. If air valve or metering rod is damaged, the air horn assembly must be replaced.

(e) Rough Engine Idle:

1. Inspect gasket and gasket mating surfaces on castings for damage to sealing beads, nicks, burrs and other defects.

2. Clean all idle fuel passages.

3. If removed, inspect idle mixture screw tip for ridges, burrs and distortion.

4. Inspect throttle lever and valves for binding, nicks and other defects.

5. Examine all diaphragms for possible ruptures and leaks.

6. Clean plastic components with clean, soft, dry cloth.

Assembly

(1) Install slow idle speed screw and spring, if removed, in throttle body (fig. 1J-43).

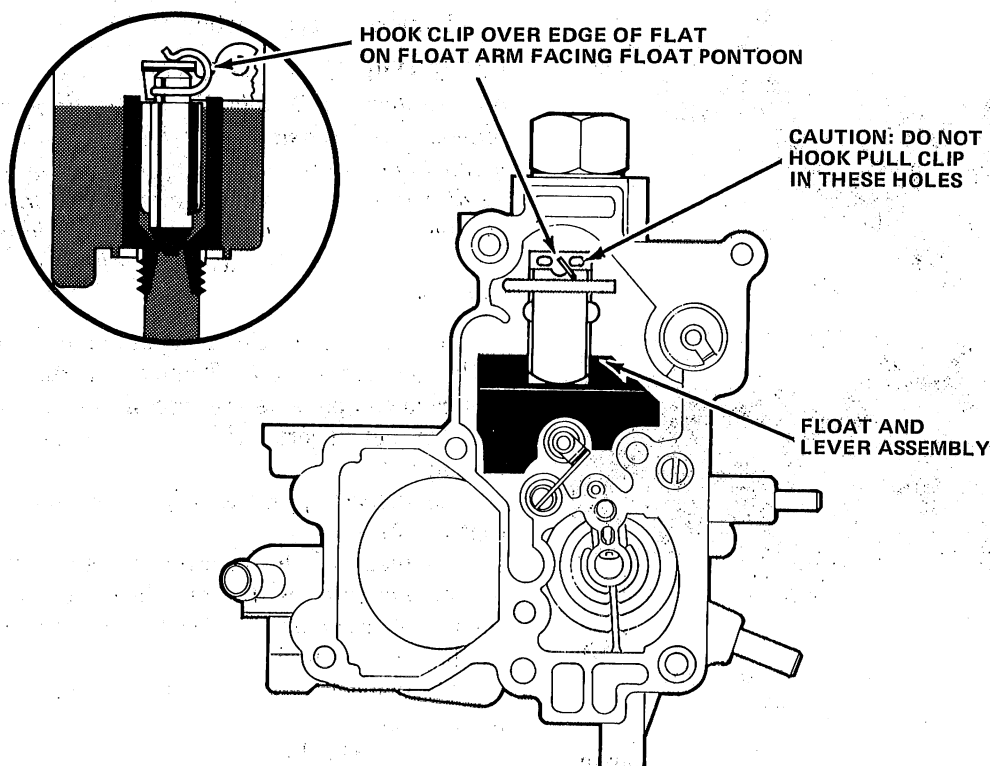

Fig. 1J-46 Model 2SE Carburetor—Float Needle Pull Clip Location

(2) If removed, install fast idle adjustment screw and clip in primary throttle lever (fig. 1J-43).

(3) Holding primary throttle lever wide open, install lower end of pump rod in throttle lever by aligning notch on rod with slot in lever. End of rod should point outward toward throttle lever.

(4) If removed, install idle mixture screw, washer (if used), and spring with Tool J-29030 (fig. 1J-45). Lightly seat screw and back out three turns for preliminary idle mixture adjustment. Final idle mixture adjustment must be with carburetor installed on engine using procedures described within Idle Mixture Adjustment.

NOTE: If a new float bowl assembly is used, stamp or engrave the model number on the new float bowl (fig. 1J-19).

(5) Install new throttle body-to-bowl insulator gasket over two locating dowels on bowl.

(6) Holding fast idle cam so that cam steps face fast idle adjustment screw on throttle lever when properly installed, install throttle body ensuring it is properly located over dowels on float bowl (fig. 1J-47). Install four throttle body-to-bowl screws and lockwashers and tighten securely (fig. 1J-42).

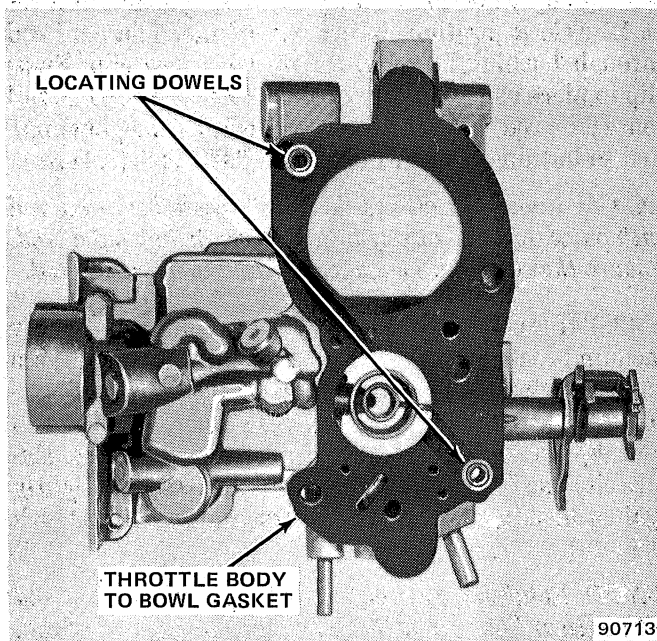

**Fig. 1J-47 Model 2SE Carburetor—
Throttle Body-to-Bowl Insulator Gasket**

NOTE: Inspect linkage to ensure lockout tang is located properly to permit engaging slot in secondary lockout lever and that linkage moves freely.

(7) Place carburetor on proper holding fixture (J-9789-118).

CAUTION: When properly installed, hole in filter faces toward inlet. Ribs on closed end of filter element

prevent filter from being installed incorrectly unless forced. Tightening in excess of specified torque can damage nylon gasket and cause fuel leak.

(8) Install fuel inlet filter spring, check valve and filter assembly, new gasket and inlet fitting. Tighten fitting with 25 foot-pounds (34 N•m) torque.

CAUTION: When installing a service replacement filter, ensure the filter is the type that includes a check valve that conforms to U.S. Motor Vehicle Safety Standards.

(9) Install choke housing on throttle body, ensuring raised boss and locating lug on rear of housing fit into recesses in float bowl casting (fig. 1J-41). Install two choke housing attaching screws and lockwashers in throttle body and tighten screws evenly and securely.

(10) Install intermediate choke shaft and lever assembly in float bowl by pushing through from throttle lever side (fig. 1J-40).

(11) With intermediate choke lever in UP (12 o'clock) position, install bimetallic coil lever inside choke housing onto flats on intermediate choke shaft. Coil is properly aligned when coil pick-up tang is at top (12 o'clock) position (fig. 1J-48). Install inside lever retaining screw into end of intermediate choke shaft and tighten securely.

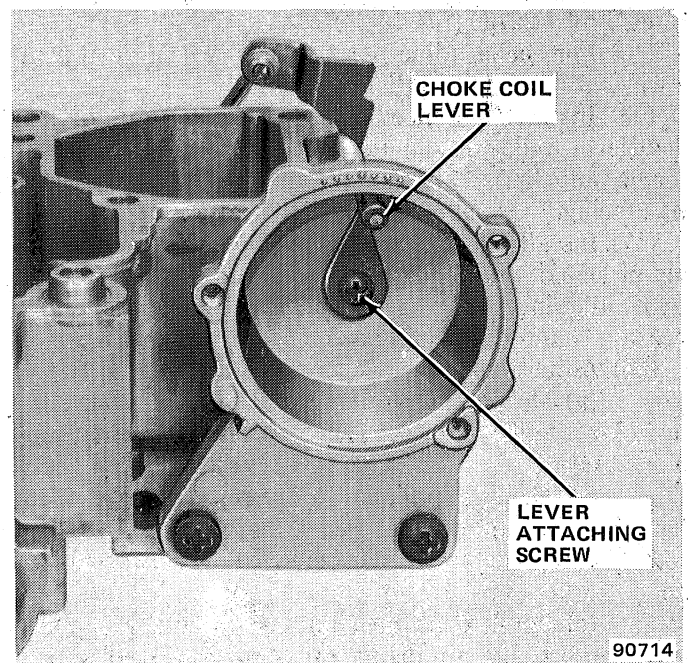

Fig. 1J-48 Model 2SE Carburetor—Installed Choke Coil Lever

NOTE: Do not install choke cover and bimetallic coil assembly in housing until inside coil lever is adjusted (refer to Service Adjustment Procedures).

(12) Install pump discharge steel check ball and spring in passage adjacent to float chamber (fig. 1J-49). Insert end of replacement plastic retainer into end of spring and install retainer in float bowl. Tap lightly in place until top of retainer is flush with bowl casting surface.

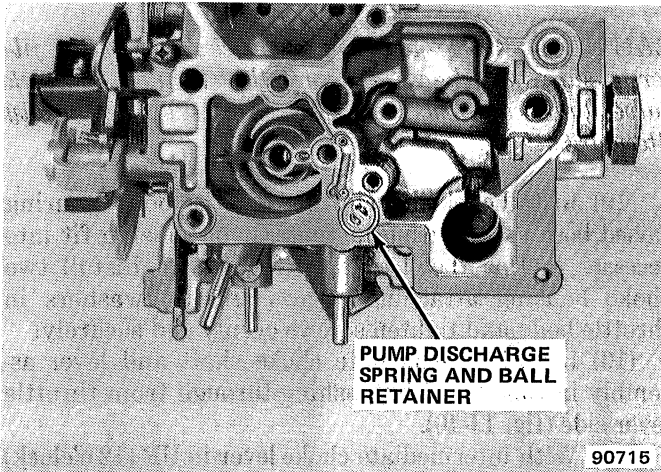

Fig. 1J-49 Model 2SE Carburetor—Pump Discharge Retainer Installed

(13) Using Tool J-22769 or screwdriver that fully fits slot in top, install main metering jet into bottom of float chamber. Tighten jet securely.

(14) Install inlet needle seat assembly with gasket using Tool J-22769 (fig. 1J-34).

(15) For easier adjustment, carefully bend float arm inward at notch in arm before assembly.

(16) Install float needle onto float arm by sliding float lever under needle pull clip. Correct installation of needle pull clip is to hook clip over edge of float on float arm facing float pontoon (fig. 1J-20 and 1J-46).

(17) Install float retaining pin into float arm with end of loop of pin facing pump well. Install float assembly by aligning needle in seat and float retaining pin into locating channels in float bowl.

(18) Adjust float level:

(a) Hold float retaining pin firmly in place and push down lightly on float arm at outer end against top of float needle.

(b) Using adjustable "T" scale, at a point $3/16$ inch from end of float at toe, measure distance from float bowl top surface (gasket removed) to top of float at toe.

(c) Bend float arm as necessary for proper adjustment by pushing on pontoon (refer to Specifications).

(d) Visually inspect float alignment after adjustment.

(19) Install power piston spring into piston bore.

(20) If removed, attach metering rod to holder on power piston. Spring must be on top of arm when assembled correctly (fig. 1J-36).

(21) Install power piston and metering rod assembly into float bowl and main metering jet. Use care installing metering rod into jet to prevent damaging metering rod tip. Press down firmly on plastic power piston retainer to ensure retainer is seated in recess in bowl and top is flush with top of bowl casting. If necessary, tap retainer lightly in place using drift and small hammer.

(22) Install plastic filler block over float needle by pressing downward until properly seated (flush with bowl casting surface).

(23) Install air horn gasket on float bowl by carefully sliding slit portion of gasket over two dowel locating pins on float bowl.

(24) Install pump return spring in pump well.

(25) Install pump plunger assembly in pump well.

CAUTION: Inspect choke valve for freedom of movement and proper alignment before staking screws in place.

(26) If removed, install choke shaft, choke valve and two attaching screws. Tighten screws securely and stake lightly in place.

(27) If removed, install plastic bushing in lower hole in choke lever ensuring small end of bushing faces retaining clip when installed. With inner choke coil lever at 12 o'clock position, insert end of fast idle cam rod through bushing in lever. Retain with new clip. Press clip in place using needlenose pliers. Ensure clip has full contact on rod, but is not seated tightly against bushing. Rod-to-bushing clearance should be 0.030 inch (0.8 mm).

NOTE: Retaining clip is "dished." Install clip on rod with outward bend of self-locking lugs facing end of rod. Ensure that clip fully engages rod and is not distorted.

(28) If removed, install plastic bushing in hole in vacuum break lever ensuring small end of bushing faces retaining clip when installed. Next, insert end of vacuum break rod through bushing in lever. Retain with new clip. Press clip in place with needlenose pliers. Ensure clip has full contact on rod, but is not seated tightly against bushing. Rod-to-bushing clearance is 0.030 inch (0.8 mm).

NOTE: Retaining clip is "dished." Install clip on rod with outward bend of self-locking lugs facing end of rod. Ensure that clip fully engages rod and is not distorted.

(29) If removed, install plastic bushing in hole in air valve lever. Ensure small end of bushing faces retaining clip when installed. Next, insert end of air valve rod through bushing in lever. Retain with new clip. Press clip in place with needlenose pliers. Ensure clip has full contact on rod, but is not seated tightly against bushing. Rod-to-bushing clearance is 0.030 inch (0.8 mm).

NOTE: Retaining clip is "dished." Install clip on rod with outward bend of self-locking lugs facing end of rod. Ensure that clip fully engages rod and is not distorted.

(30) Rotate fast idle cam to full UP position and tilt air horn assembly to engage fast idle cam rod in slot in fast idle cam (fig. 1J-32). Next, holding down on pump plunger assembly, carefully lower air horn assembly onto float bowl while guiding pump plunger stem through hole in air horn casting.

NOTE: Do not force air horn assembly onto bowl.

(31) Install vent screen assembly on air horn assembly (fig. 1J-31) and install six air horn-to-bowl attaching screws and lockwashers.

NOTE: Three medium long air horn screws are installed in the primary and secondary venturi area. The two longer screws hold the vent screen assembly in place. The two short screws are installed on the fuel inlet side. One short screw is installed in the area beneath the hot idle compensator valve. All air horn screws must be tightened evenly and securely. Refer to figure 1J-50 for proper tightening sequence.

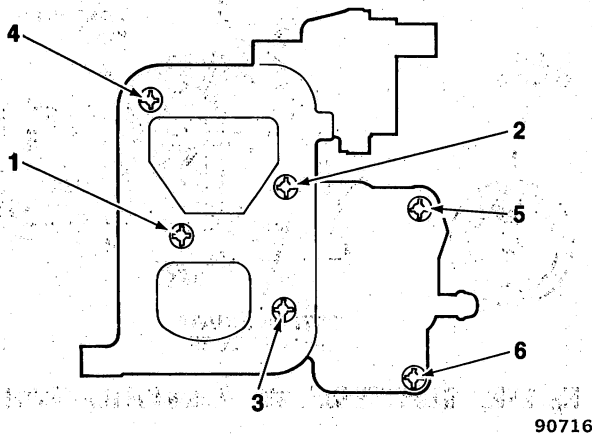

**Fig. 1J-50 Model 2SE Carburetor—
Air Horn Screw Tightening Sequence**

(32) If equipped, install replacement seal in recess of float bowl. Install hot idle compensator valve and retain with two small attaching screws. Tighten screws securely.

(33) Install plastic bushing in hole in choke lever. Ensure small end of bushing faces retaining clip when installed. With inner choke coil lever at 12 o'clock position, insert intermediate choke rod in bushing. Retain rod with replacement clip using needle-nose pliers.

NOTE: Retaining clip is "dished." Install clip on rod with outward bend of self-locking lugs facing end of rod. Ensure that clip fully engages rod and that clip is not distorted.

CAUTION: Use care when tightening nut to avoid damaging vacuum break diaphragm plunger.

(34) If removed, install solenoid in hole on bracket with large lockwasher and retaining nut. Tighten nut securely and bend back two retaining tabs on lockwasher and position in slots in bracket.

(35) Rotate solenoid bracket and insert end of vacuum break rod into inner slot and end of air valve rod into outer slot of vacuum break diaphragm plunger. Install bracket over locating lugs on air horn. Install tapered-seat screw in air horn and screw with lockwasher in throttle body. Tighten screws securely (fig. 1J-28).

NOTE: Do not connect vacuum break hose until after vacuum break adjustment is completed (refer to Service Adjustment Procedures).

(36) Insert pump rod in hole in pump lever by rotating lever (fig. 1J-27). Install retaining screw in pump lever, then washer. While holding down on pump plunger stem, install pump lever on air horn. Ensure shoulder on screw seats in hole in lever and washer is positioned between lever and air horn casting. Tighten screw securely.

NOTE: The vacuum break and choke rod (fast idle cam) adjustments must be completed, and the bimetallic coil lever inside the choke housing must be indexed properly before the choke bimetallic coil and cover assembly are installed. Refer to the Service Adjustment Procedures.

(37) Place fast idle screw on highest step of fast idle cam.

(38) Install cover and bimetallic coil assembly on choke housing, aligning notch in cover with raised casting projection on housing cover flange. Ensure coil pickup tang engages inside choke coil lever.

(39) Install three choke cover retainers with three drive rivets.

(40) With small punch and hammer, drive rivet pin into each rivet to expand and seat rivets in place.

NOTE: Ground contact for the choke electric heater is provided by a metal plate located at the rear of the choke assembly. Do not install a gasket between the choke cover assembly and the choke housing. The choke heater will not operate unless properly grounded.

SERVICE ADJUSTMENT PROCEDURES

Float Level Adjustment

With the air horn removed:

(1) Hold retainer pin firmly in place and push float down lightly against needle (fig. 1J-51).

(2) Using adjustable "T" scale, at a point 3/16 inch (4.8 mm) from end of float at toe, measure distance from float bowl top surface (gasket removed) to top of float at toe (fig. 1J-51).

(3) Remove float and bend float arm as necessary to adjust. Refer to Specifications.

(4) Visually check float alignment after adjustment.

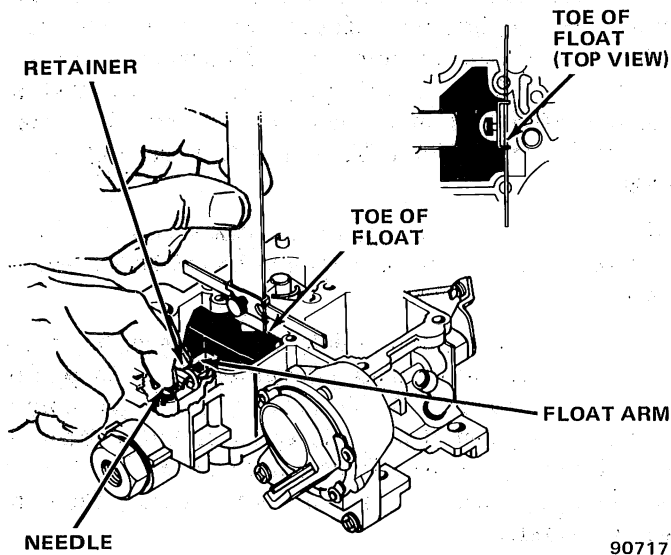

90717

Fig. 1J-51 Model 2SE Carburetor—Float Adjustment

Accelerator Pump Adjustment

The pump adjustment should not be changed from the original factory assembly adjustment unless measurement indicates it is not within the specification. The pump lever is hardened steel and bending it is very difficult. Do not attempt to bend unless absolutely necessary.

(1) With throttle valves completely closed and fast idle adjustment screw off fast idle cam step, measure distance from air horn casting to top of pump stem. Refer to Specifications.

(2) If adjustment is necessary, remove pump lever retaining screw and lever by rotating from pump rod.

CAUTION: Do not bend lever sideways or twist it.

(3) Place lever in soft jawed vise and bend end of lever as necessary to obtain correct dimension.

(4) Install pump lever and retaining screw.

(5) Check adjustment and if correct tighten retaining screw securely.

(6) Open and close throttle valves to test linkage for freedom of movement and lever for correct alignment.

Fast Idle Adjustment

(1) Position fast idle adjustment screw on highest fast idle cam step.

(2) Turn fast idle adjustment screw in or out the specified number of turns. Refer to Specifications.

Choke Coil Lever Adjustment

Do not remove the rivets and retainers securing the choke cover and coil assembly unless it is necessary to inspect the choke coil lever adjustment. If the rivets and cover are removed, a choke cover retainer kit is required for assembly.

(1) Remove rivets, retainers and choke cover and coil assembly following instructions contained in choke cover retainer kit.

(2) Position fast idle adjustment screw on highest fast idle cam step.

(3) Push on intermediate choke lever and close choke valve.

(4) Insert specified plug gauge in hole adjacent to coil lever (see Specifications). Edge of lever should barely contact plug gauge (fig. 1J-52).

(5) Bend intermediate choke rod with Adjusting Wrench J-28692 to adjust clearance between lever and plug gauge (fig. 1J-52).

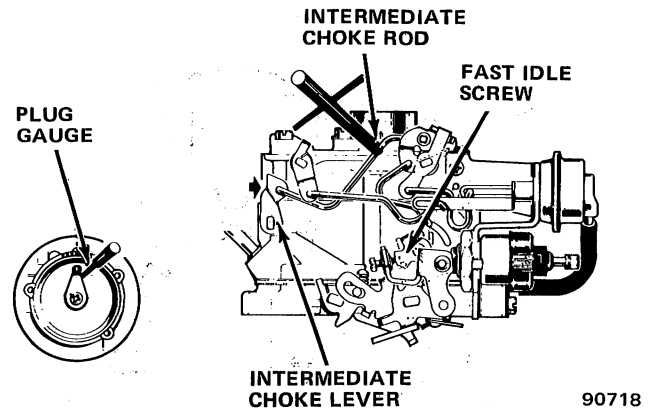

90718

Fig. 1J-52 Model 2SE Carburetor—Choke Coil Lever Adjustment

Fast Idle Cam Position Adjustment

The choke coil lever adjustment must be correct and the fast idle adjustment must be completed before proceeding (fig. 1J-53).

(1) Rotate degree scale of Carburetor Choke Angle Gauge J-26701-A to position zero degree mark opposite pointer.

(2) With choke valve completely closed, position magnet squarely on top of choke valve. Rotate bubble until it is centered.

(3) Rotate degree scale until degree mark specified for adjustment is opposite pointer. Refer to Specifications.

(4) Position fast idle screw on second cam step adjacent to rise of high step.

(5) Close choke valve by pushing on intermediate choke lever.

(6) Push vacuum break lever toward open choke position until lever is against rear tang on choke lever.

- (7) Adjust by bending fast idle cam rod with Bending Tool J-9789-111 until bubble is centered.
- (8) Remove gauge.

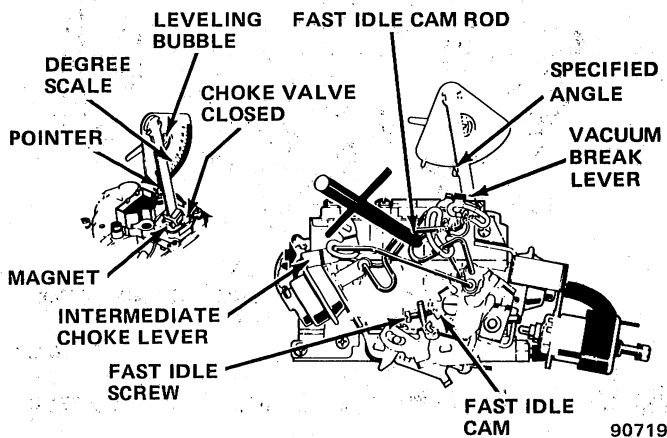

Fig. 1J-53 Model 2SE Carburetor—Fast Idle Cam Position Adjustment

Air Valve Rod Adjustment

Refer to figure 1J-54.

- (1) Rotate degree scale of Carburetor Choke Angle Gauge J-26701-A to position zero degree mark opposite pointer.
- (2) Close air valve and place magnet on top of it.
- (3) Rotate bubble until it is centered.
- (4) Rotate degree scale until specified degree mark (refer to Specifications) is opposite pointer.
- (5) Seat vacuum diaphragm using external vacuum source.

NOTE: Plug end cover with tape if purge bleed hole is used. Remove tape after adjustment.

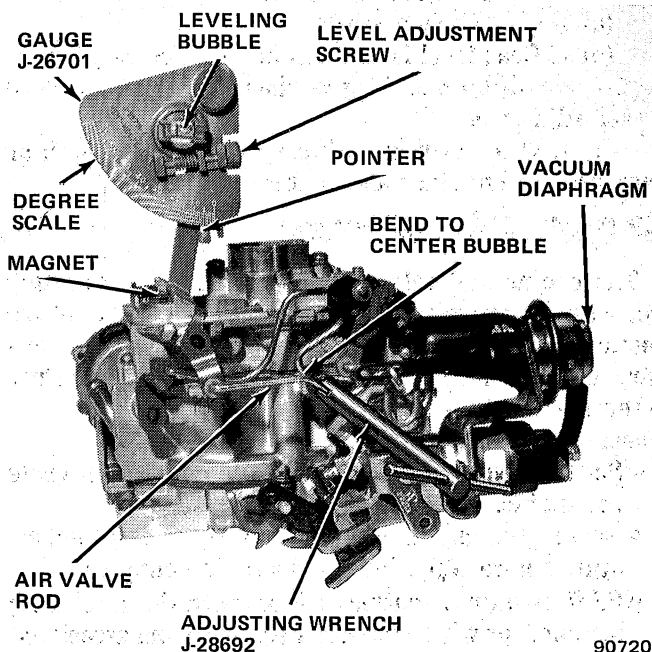

Fig. 1J-54 Model 2SE Carburetor—Air Valve Rod Adjustment

- (6) Apply light pressure to air valve shaft in direction to open valve to ensure all slack is removed between air valve rod and plunger slot.
- (7) Bend air valve rod with Bending Tool J-9789-111 until bubble is centered.
- (8) Remove gauge.

Primary Side Vacuum Break Adjustment

Refer to figure 1J-55.

- (1) Rotate degree scale of Carburetor Choke Angle Gauge J-26701-A until zero degree mark is opposite pointer.
- (2) Completely close choke valve and place magnet squarely on top of it.

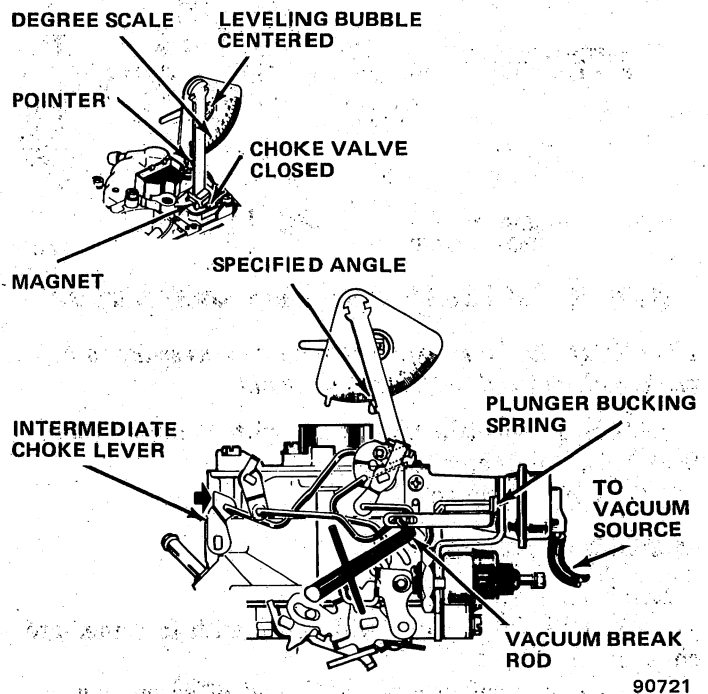

Fig. 1J-55 Model 2SE Carburetor—Primary Side Vacuum Break Adjustment

- (3) Rotate bubble until it is centered.
- (4) Rotate degree scale to position specified degree mark (refer to Specifications) opposite pointer.
- (5) Seat choke vacuum diaphragm using external vacuum source.
- (6) Hold choke valve at closed position by pushing on intermediate choke lever. Ensure plunger backing spring (if used) is compressed and seated.
- (7) Bend vacuum break rod with Bending Tool J-9789-111 to center bubble.
- (8) Remove gauge.

Choke Unloader Adjustment

Refer to figure 1J-56.

- (1) Rotate degree scale of Carburetor Choke Angle Gauge J-26701-A until zero degree mark is opposite pointer.

- (2) Close choke valve completely and set magnet squarely on top of it.
- (3) Rotate bubble until it is centered.
- (4) Rotate degree scale to position specified degree mark (refer to Specifications) opposite pointer.
- (5) Hold primary throttle valve wide open.

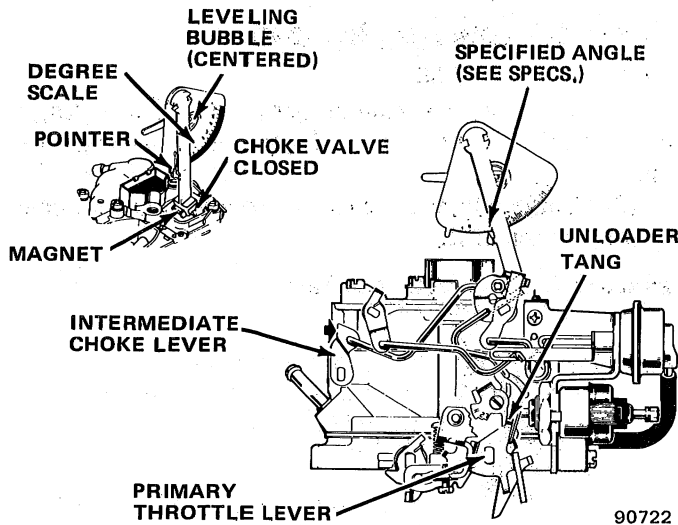

Fig. 1J-56 Model 2SE Carburetor—Choke Unloader Adjustment

NOTE: If engine is warm it may be necessary to hold choke valve closed with a rubber band.

- (6) Bend throttle lever tang with Bending Tool J-9789-111 until bubble is centered.
- (7) Remove gauge.

Secondary Lockout Adjustment

Refer to figure 1J-57.

- (1) Hold choke valve wide open with intermediate choke lever.
- (2) Open throttle lever until end of secondary actuating lever is opposite toe of lockout lever.
- (3) Measure clearance (refer to Specifications) between toe of lockout lever and secondary actuating lever.
- (4) If adjustment is necessary, bend lockout lever tang contacting fast idle cam with Bending Tool J-9789-111.

Float Level Measurement

NOTE: The float level should be determined before disassembling a carburetor for overhaul if a malfunctioning float is suspected of affecting engine performance.

NOTE: The fuel level in the carburetor bowl can be affected by fuel pump pressure as well as by an improperly adjusted float.

- To determine if the float requires adjustment, measure the float level according to the following procedure.
- (1) Remove vent stack screws and vent stack.
 - (2) Remove air horn screw located adjacent to vent stack.

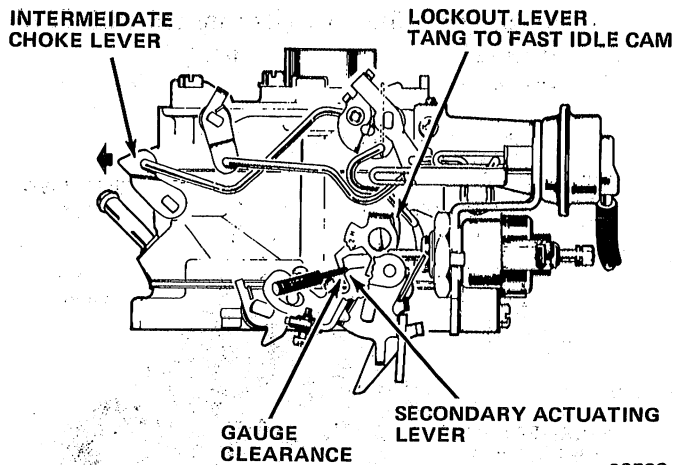

Fig. 1J-57 Model 2SE Carburetor—Secondary Lockout Adjustment

WARNING: Use extreme caution when engine is operating. Do not stand in direct line with fan. Do not put hands near pulleys, belts or fan. Do not wear loose clothing.

- (3) With engine at idle speed and choke valve completely open, carefully insert float gauge in air horn screw hole and vent hole. Allow gauge to rest freely on float.

NOTE: Use Gauge J-9789-138 (blue) for model 2SE carburetor.

CAUTION: Do not press down on gauge because engine may flood or float may be damaged.

- (4) With gauge at eye level observe mark on gauge that aligns with top of casting at vent hole. Float level should be within ± 1.5 mm (± 0.06 inch) of float level specification. Refer to Specifications.
- (5) Remove float gauge.
- (6) If float level is not within specification, remove carburetor air horn and adjust float level. Refer to Float Level Adjustment.
- (7) If float level is within specification, install air horn screw, vent stack and vent stack screws.

Idle Speed and Mixture Adjustment

The engine and related systems must be operating normally before performing curb (slow) idle speed adjustment. Idle mixture adjustment should not be necessary unless, during carburetor overhaul, the mixture screw position was altered.

Precautions and General Information

- Set the parking brake firmly and do not accelerate the engine.
- Ensure the engine is at normal operating temperature before adjusting idle speed and mixture.
- Perform adjustment procedures with the air cleaner installed, or with air cleaner removed and associated vacuum hoses plugged. Choke must be open and deceleration valve supply hose plugged.

- Do not idle the engine more than three minutes at a time.
- If the mixture adjustment procedure requires more than three minutes, operate the engine at 2000 rpm for one minute.
- Ensure the ignition timing is correct before adjusting idle speed.
- Use extreme caution around fan, belts and other moving parts when the engine is operating. Do not wear loose clothing. Do not stand in direct line with the fan blades.

Curb (Slow) Idle Speed Adjustment

(1) Disconnect and plug purge vacuum hose at vapor canister.

NOTE: Use a tachometer with an expanded scale of 400 to 800 or 0 to 1000 rpm. Inspect tachometer periodically to ensure accuracy within two percent.

(2) Connect tachometer.

WARNING: Use extreme caution when engine is operating. Do not stand in direct line with fan. Do not put hands near pulleys, belts or fan. Do not wear loose clothing.

(3) Start engine and warm to normal operating temperature.

(4) Set parking brake firmly.

(5) Place manual transmission into Neutral.

(6) Adjust idle speed by turning solenoid idle screw to obtain specified idle speed.

(7) Disconnect solenoid wire connector. Adjust curb idle screw to obtain 500 rpm.

(8) Connect solenoid wire connector.

(9) Stop engine. Disconnect tachometer. Install air cleaner (if removed) and connect vacuum hoses (if disconnected). Connect canister purge hose and deceleration valve supply hose (if disconnected).

Carburetor Model 2SE Idle Speed Adjustment Specifications

Engine	Transmission	RPM
4-Cylinder	Manual	900 (± 100) ⊕

⊕ Idle speed with solenoid de-energized is 500 rpm.

90978

Fast Idle Speed Adjustment

(1) Connect tachometer.

(2) Set parking brake and place manual transmission in Neutral.

(3) Connect tachometer.

WARNING: Use extreme caution when engine is operating. Do not stand in direct line with fan. Do not put hands near pulleys, belts or fan. Do not wear loose clothing.

(4) Start and warm engine to normal operating temperature.

- (5) Disconnect and plug EGR valve vacuum hose.
- (6) Open throttle slightly and rotate fast idle cam until adjustment screw is against highest step of cam.
- (7) Adjust fast idle speed to specification.
- (8) Quickly open throttle slightly and allow engine to return to slow idle speed.
- (9) Connect EGR valve vacuum hose.
- (10) Disconnect tachometer.

Idle Mixture Adjustment

Idle mixture adjustment should only be performed if the mixture adjustment screw position was disturbed or replaced during carburetor overhaul.

(1) Position manual transmission in Neutral position. Set parking brake.

WARNING: Use extreme caution when engine is operating. Do not stand in direct line with fan. Do not put hands near pulleys, belts or fan. Do not wear loose clothing.

(2) Connect tachometer, start engine and warm to operating temperature.

NOTE: Use a tachometer with an expanded scale of 400 to 800 or 0 to 1000 rpm. Inspect tachometer periodically to ensure accuracy within two percent.

(3) Adjust idle speed as described above.

(4) Turn idle mixture adjustment screw lean (clockwise) until perceptible loss of rpm is noted.

(5) Turn idle mixture adjustment screw rich (counterclockwise) until highest rpm is attained. Do not turn screw any further than position where highest rpm is first attained. This is referred to as lean best idle.

NOTE: Engine speed will increase above idle speed an amount that corresponds approximately to the lean drop specification obtained in step (6).

(6) As final adjustment, turn idle mixture adjustment screw clockwise in increments until specified drop is attained. Refer to Idle Drop Specification.

NOTE: If the final rpm differs more than ± 30 rpm from the originally adjusted idle speed, readjust idle speed to specification and repeat steps (6) and (7).

Carburetor Model 2SE Idle Mixture Adjustment Idle Drop

Engine	Transmission	RPM Drop
4-Cylinder	M	100

90979

Choke Mechanism Service

Test the choke mechanism and vacuum break for proper operation at the recommended maintenance intervals. Any binding condition that may have developed

because of petroleum gum formation on the choke shaft or from damage should be corrected. Inspect the vacuum break hose for proper connection, cracks, abrasion and general deterioration. Correct or replace as necessary.

General Inspection

(1) Remove air cleaner. With engine off, hold throttle half open. Open and close choke several times. Observe linkage and ensure all links are connected and that there are no indications of damage.

(2) If choke or linkage binds, sticks or moves sluggishly, clean with AMC Choke and Linkage Cleaner, or equivalent. Use cleaner as directed on can. If cleaning does not correct the problem, replace malfunctioning parts.

(3) Visually inspect carburetor and ensure all vacuum hoses are connected. Inspect hoses for cracks, abrasion, hardness or indications of general deterioration. Replace or correct as necessary.

(4) Ensure vacuum break diaphragm shafts are fully extended when engine is off. If shafts are not fully extended, replace vacuum break assembly. Start engine; primary vacuum break diaphragm shaft should fully retract. If unit fails to retract, replace vacuum break assembly.

Electric Choke Heater

If the choke fails to operate properly, perform the following tests.

(1) Measure voltage at choke heater wire connection with engine operating. If voltage is between 12 and 15 volts, replace choke unit.

(2) If voltage is low or zero, inspect all wires and connections. If connection at oil pressure switch is faulty, low pressure warning light may also be inoperative with ignition on and engine not started. Repair wires and connections as necessary.

(3) If tests in steps (1) and (2) have normal results, replace oil pressure switch.

Carburetor Model 2SE Specifications

	17082380	17082381
Pri. Throttle Bore	35 mm	35 mm
Sec. Throttle Bore	46 mm	46 mm
Pri. Venturi Diameter	28 mm	28 mm
Sec. Venturi Diameter	Var. Air Valve	Var. Air Valve
Fuel Inlet Seat Diameter	(.093")	(.093")
Idle Bypass	2.20 mm	2.20 mm
Idle Tube	0.825 mm	0.80 mm
Side Idle Air Bleed	1.32 mm	1.32 mm
Lower Idle Air Bleed	1.32 mm	1.32 mm
Spark Port Size	1.14mm x 3.84mm	1.14mm x 3.84mm
Main Jet	No. 159 (1.59 mm)	No. 150 (1.50 mm)
Pri. Metering Rod No.	17057856	17057-855
Sec. Metering Rod No.	17071356	17071356
Top Well Bleed	1.78 mm	1.78 mm
Side Well Bleed	2.44 mm	2.44 mm
Power Valve Timing	6 to 2" Hg.	4 to 1" Hg.
Accelerator Nozzle Dia.	0.50 mm	0.50 mm

4-Cylinder Engine	Carburetor Number	Float Level mm(inches)	Pump Stem Height mm(inches)	Fast Idle Cam Adj.ⓐ	Fast Idle Speed ±100 rpm	Air Valve Linkⓑ	Vac. Break Pri.	Unloader	Choke	Secondary Lockout	Choke Coil Lever Plug Gauge
CJ (49 State)	Man. Trans. 17082380	4.5 (.169)	3.25 (.128)	18°	2400	2°	21°	34°	TR	1.27-2.03mm (.050-.080in.)	1.27-2.03mm (.050-.080in.)
CJ Hi-Alt.	Man. Trans. 17082381	4.5 (.169)	3.25 (.128)	18°	2400	2°	21°	34°	TR	1.27-2.03mm (.050-.080in.)	1.27-2.03mm (.050-.080in.)

ⓐ Maximum Degree Setting
 TR Tamper Resistant
 ⓑ Second Step of Cam

**CARBURETOR MODEL E2SE—
2 VENTURI**

	Page
Carburetor Circuits	1J-31
Carburetor Overhaul	1J-35
Carburetor Replacement	1J-34

	Page
General	1J-30
Service Adjustment Procedures	1J-45
Specifications	1J-46

GENERAL

The Model E2SE carburetor is a two-venturi, two-stage carburetor of down draft design (fig. 1J-58) for

four-cylinder engines installed in CJ vehicles manufactured for sale in California.

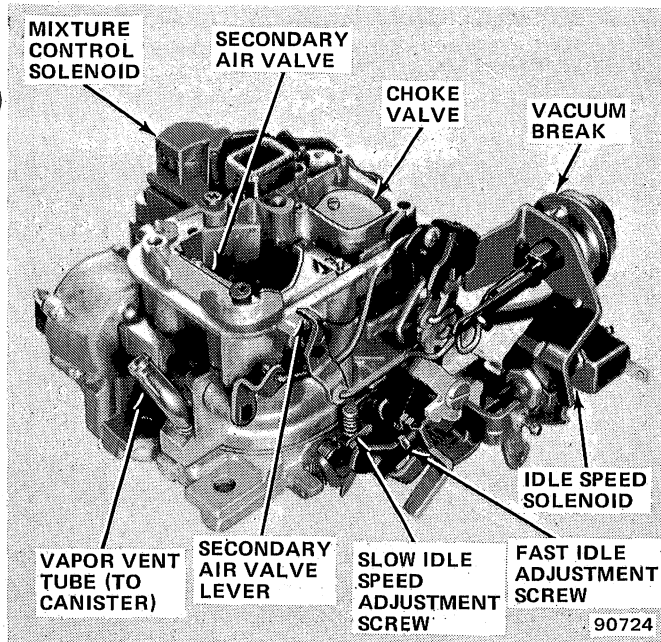

Fig. 1J-58 Model E2SE Carburetor

NOTE: All reference to CJ vehicles also pertains to Scrambler vehicles.

When used with the C4 system, the Model E2SE carburetor includes special design features for optimum air/fuel mixture control during all ranges of engine operation. An electrically operated mixture control solenoid, located in the air horn, is used to control air and fuel metered to the idle and main metering systems of the carburetor. A plunger in the end of the solenoid is submerged in fuel in the fuel chamber of the float bowl. The solenoid is turned on and off (or "pulsed") by the Electronic Control Module (ECM). The ECM, responding to the amplitude of the voltage at the oxygen sensor in the exhaust manifold and other engine operating conditions, energizes the solenoid to move the plunger down to the lean position or, de-energizes it to the rich position to control fuel delivery to the idle and main metering circuits. The ECM energizes the solenoid by providing a ground to complete the path for current flow. The solenoid has 12 volts (battery voltage) applied to it at all times while the ignition switch is on. When the plunger is in the down (lean) position, fuel metering is controlled by a factory adjusted lean mixture screw located in the float bowl. When the plunger is in the up (rich position), additional fuel is metered to the main fuel well through the factory adjusted rich mixture screw located at the end of the fuel supply channel in the float bowl.

In addition, air metered to the idle circuit is controlled by the up and down movement of the mixture control solenoid plunger. The plunger either increases or decreases air supplied to the idle circuit, which is further metered by a factory adjusted idle air bleed screw.

The movement (or "cycling") of the solenoid plunger, up or down, occurs ten times per second. The ratio (duty

cycle) of "on" to "off" time, or dwell period, is varied by the ECM according to the engine operating conditions. This varies the fuel and air mixture to achieve, as near as possible, optimum air/fuel mixture ratios. The exhaust gas mixture oxygen content (lean or rich), and other engine operating conditions, are constantly monitored by the C4 system microprocessor (ECM) and the air/fuel mixture is adjusted accordingly for improved exhaust emission control and good engine performance.

Identification

The carburetor model identification is stamped vertically into the float bowl at a flat area adjacent to the vacuum tube (fig. 1J-59). When replacing the fuel bowl, follow the manufacturer's instructions contained in the service repair package and ensure that the identification number is transferred to the new float bowl. Refer to the bowl part number when servicing the carburetor.

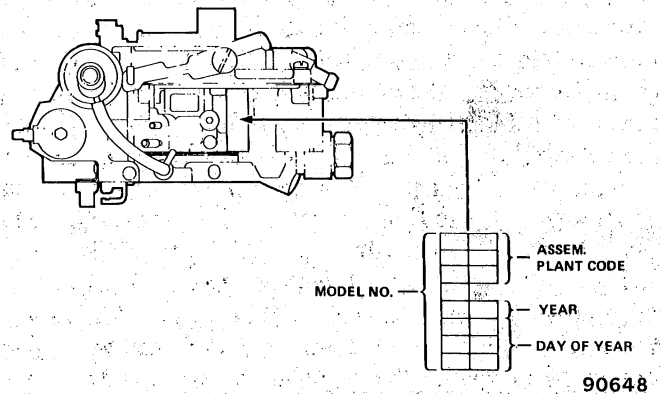

Fig. 1J-59 Model E2SE Carburetor—Identification

CARBURETOR CIRCUITS

The model E2SE carburetor has six basic circuits. They are:

- Float
- Idle
- Main Metering
- Power Enrichment
- Pump
- Choke

Float Circuit

The float chamber is located next to the primary and secondary bores (fig. 1J-60). This feature assures adequate fuel supply to both carburetor venturi bores during all normal engine operations.

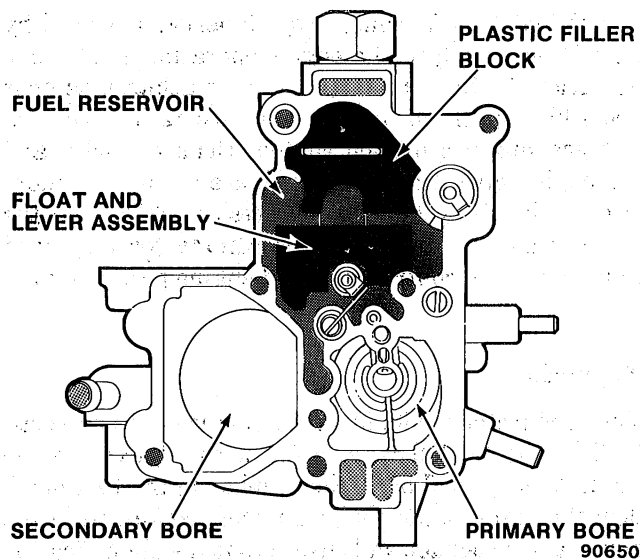

Fig. 1J-60 Model E2SE Carburetor—Float and Fuel Reservoir

A single pontoon float, brass needle seat, and rubber tipped float valve with pull clip are used to control the fuel level in the float chamber. The float chamber is internally vented through a vertical vent cavity in the air horn. Above this vent cavity is a removable vent stack assembly that has a small meshed screen for its top. The vent stack provides the correct height for the internal vent of the float chamber. The float chamber is also externally vented through a tube (fig. 1J-61) in the air horn. A hose connects this tube directly to a vacuum operated vapor vent valve located in the vapor canister. When the engine is not operating, the canister vapor vent valve is open, allowing fuel vapor from the float chamber to pass into the canister where it is stored until purged. The venting of fuel vapor from the carburetor float bowl to the canister conforms to evaporative emission requirements and improves hot engine starting.

A hot idle compensator assembly (when used) is located in the air horn casting. The opening and closing of the hot idle compensator valve is controlled by a bimetallic strip that is calibrated for a specific temperature. When the valve opens, additional air is allowed to bypass the throttle valves and enter the intake manifold to prevent rough idle during periods of hot engine operation.

An integral one-inch pleated-paper fuel filter, with check valve, is front mounted in the float bowl in ward from the fuel inlet fitting to provide good filtration of incoming fuel (fig. 1J-61). The check valve shuts off fuel flow to the carburetor and prevents fuel leaks should vehicle roll-over occur.

Idle Circuit

Fuel for idle and partial throttle engine operation is provided by the idle circuit. Fuel flows from the main well area into the idle tube and continues through the

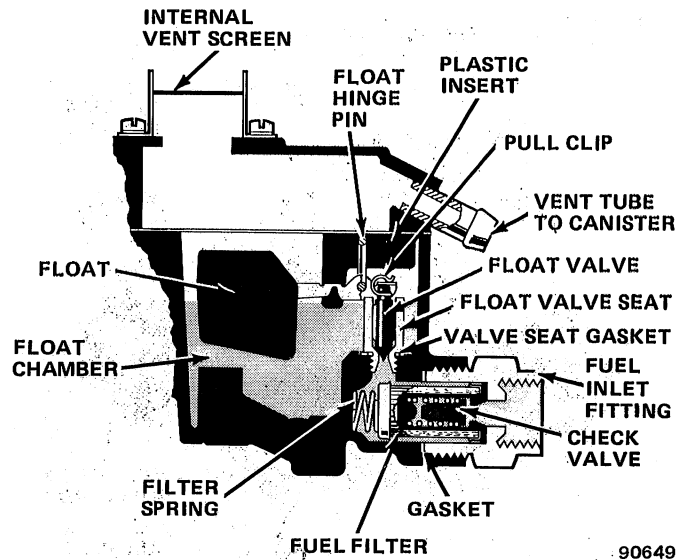

Fig. 1J-61 Carburetor Model E2SE—Float Circuit

idle cross-over passage where it is mixed with air that enters via the lower idle air bleed (fig. 1J-62).

The idle mixture adjustment screw is recessed in the throttle body casting and sealed with a hardened steel plug to discourage indiscriminate change of the factory assembly mixture adjustment, which could raise undesirable exhaust emission to a level that is beyond acceptable standards.

Main Metering Circuit

At partial throttle and cruising speed, increased airflow through the venturi creates a low pressure area in the venturi. Because air above the fuel level in the bowl is at normal pressure, fuel flows to the lower pressure area created by the venturi and amplified by the booster venturi.

The fuel flow moves past the mixture control solenoid to the main well. Air enters through the main well air bleeds. The resulting mixture of fuel and air is lighter than raw fuel; responds more quickly to changes in venturi vacuum, and is more readily vaporized when discharged into the venturi (fig. 1J-63).

Power Enrichment Circuit

Power enrichment for heavy load or high speed operation is provided by the power enrichment circuit in the secondary stage. The air/fuel mixture enrichment is accomplished by the mixture control solenoid being in the upward (rich) position the majority of the time (low dwell) and allowing fuel flow through the secondary stage of the carburetor (fig. 1J-64).

Pump Circuit

When the throttle is opened suddenly, airflow response through the carburetor is almost immediate.

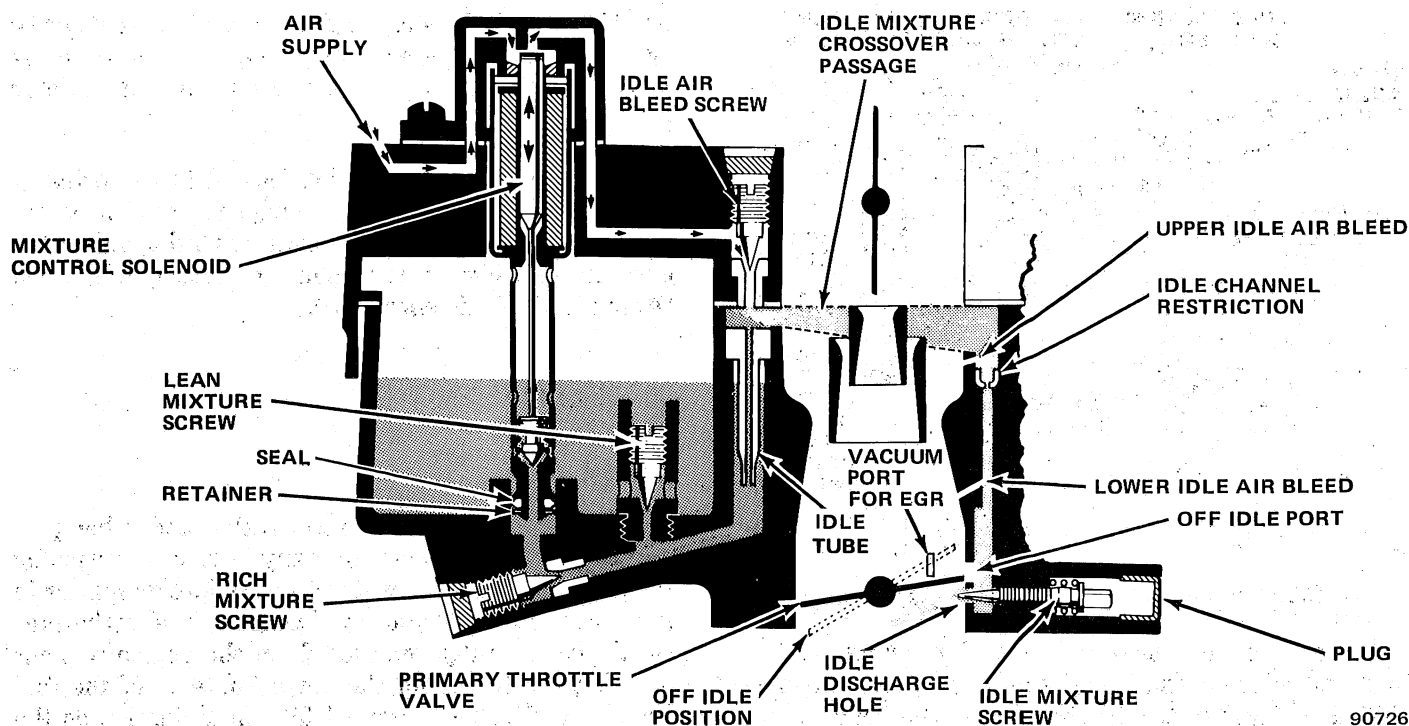

Fig. 1J-62 Carburetor Model E2SE—Idle Circuit

90726

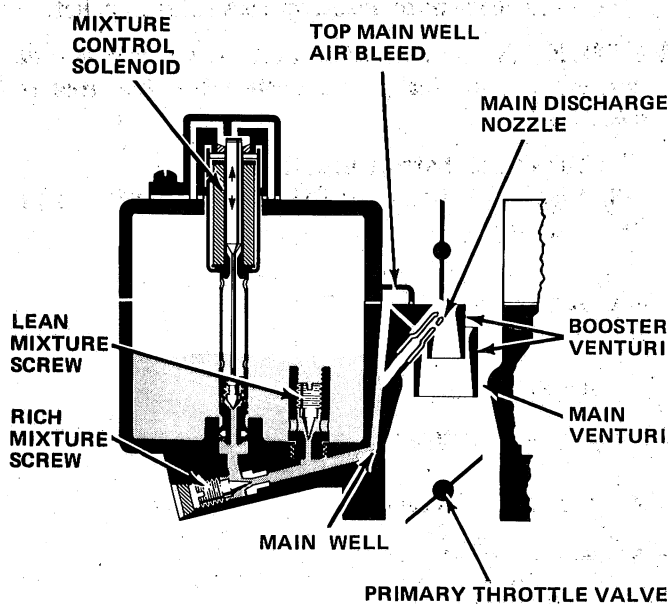

Fig. 1J-63 Carburetor Model E2SE—Main Metering Circuit

90727

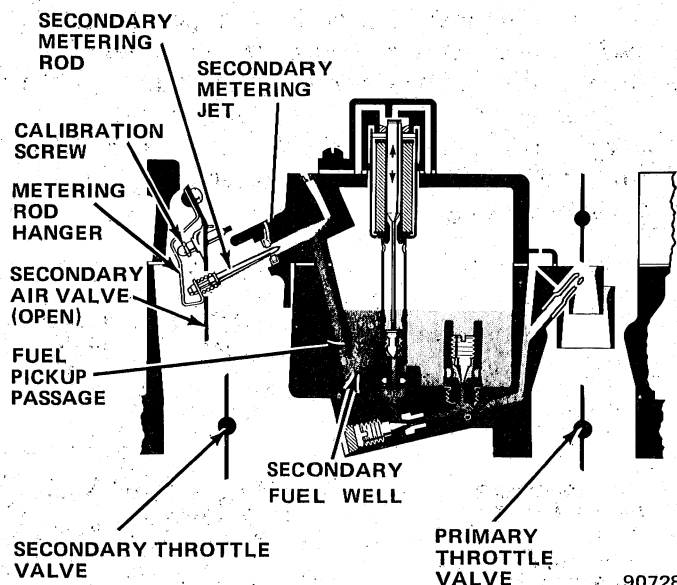

Fig. 1J-64 Carburetor Model E2SE—Power Enrichment Circuit

90728

There is a brief time lag before fuel inertia is overcome. This lag causes the desired air/fuel ratio to be leaned out. A piston-type accelerating pump system mechanically supplies the fuel necessary to overcome this deficiency (fig. 1J-65). Fuel is drawn into the pump cylinder from the fuel bowl, past the pump piston on the upward movement of the accelerator pump shaft. As the throttle lever is moved, the pump link, operating through a system of levers and assisted by the pump drive spring,

pushes the pump piston down. Fuel is forced through a passage, past the pump discharge check ball, and out the pump discharge jets in the venturi cluster.

Choke Circuit

The choke circuit in the model E2SE carburetor (fig. 1J-66) employs a single vacuum break unit that is mounted on the idle speed solenoid bracket located on the primary side of the carburetor.

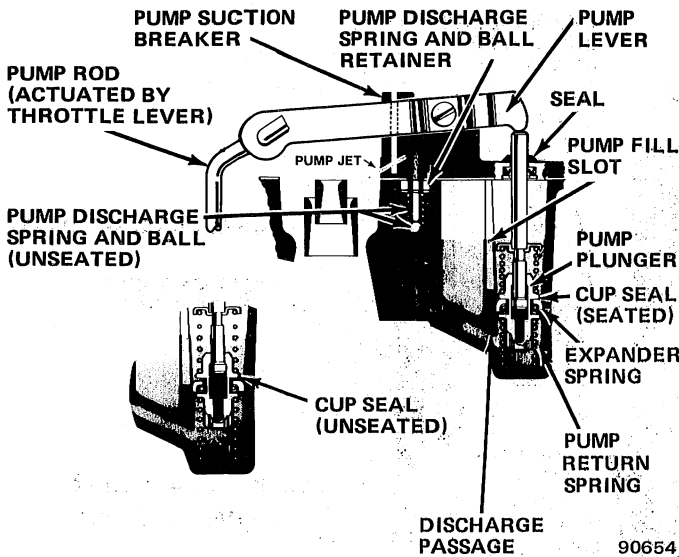

Fig. 1J-65 Carburetor Model E2SE—Pump Circuit

An electrically heated bimetallic choke coil is mounted in the choke housing located on the secondary side of the carburetor. Special rivets, and conventional retainers, are installed to retain the factory assembly adjustment of the bimetallic choke coil. They provide a tamper-resistant enclosure to discourage indiscriminate readjustment in the field. In addition, a special cutout is notched in the choke cover that must be indexed with a raised boss cast in the cover mounting flange on the choke housing. A new procedure for removal of the choke cover is required when performing major carburetor overhaul, replacement of the cover and coil assembly or choke housing.

NOTE: The choke cover and coil assembly must not be removed unless required during major carburetor overhaul, or replacement of the cover and coil assembly or choke housing is necessary.

The carburetor has a screw located in the primary throttle lever for fast idle speed adjustment. A separate screw, located in the throttle body, is used to adjust the curb or base (depending upon application) idle speed setting (solenoid de-energized).

CARBURETOR REPLACEMENT

Removal

Flooding, hesitation on acceleration and other performance complaints are, in many instances, caused by the presence of debris, water or other foreign matter in the carburetor. To aid in diagnosis, the carburetor should be carefully removed from the engine without draining the fuel from the bowl. Contents of the fuel bowl may then be examined for contamination as the carburetor is disassembled. Also, the filter should be examined for contamination.

- (1) Remove vacuum hoses, air cleaner and gasket.

WARNING: Battery negative cable must be removed to prevent a potential fire hazard when fuel line is disconnected.

- (2) Disconnect battery negative cable.
- (3) Disconnect fuel pipe fitting and vacuum hoses from carburetor.

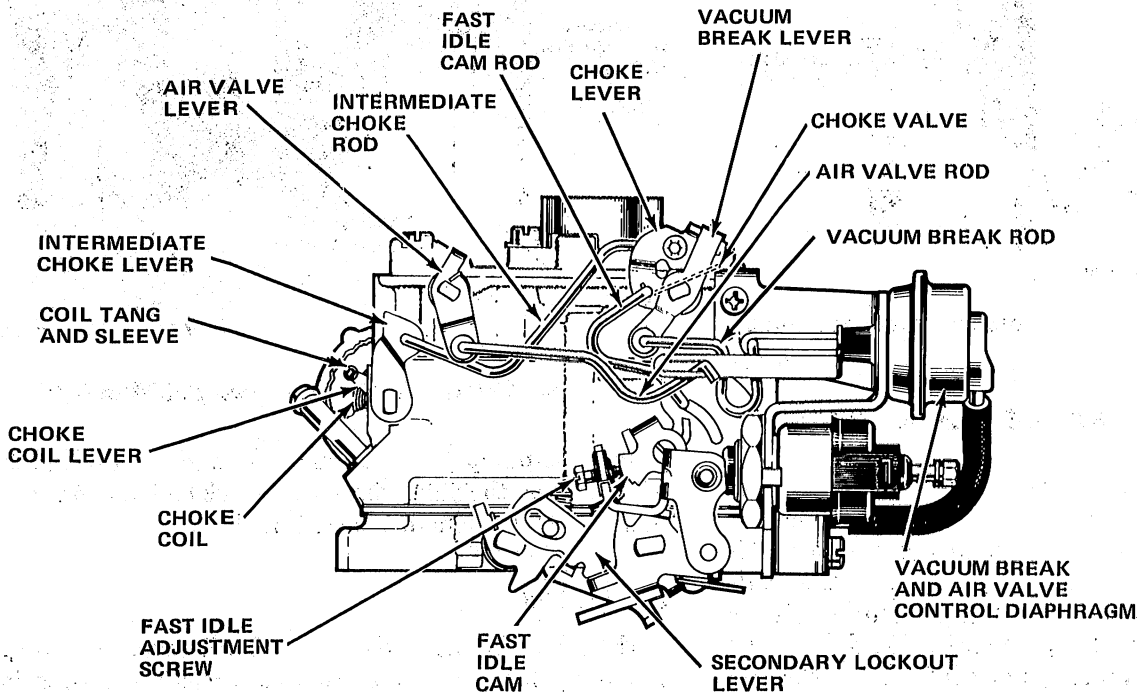

Fig. 1J-66 Carburetor Model E2SE—Choke Circuit

(4) Disconnect throttle linkage and electrical connectors.

(5) Remove carburetor attaching bolts and nuts, and remove carburetor and gasket.

Installation

Fill the carburetor bowl with fuel before installing the carburetor. This reduces strain on the starter motor and battery, and reduces the possibility of backfire while attempting to start the engine. A small supply of no-lead fuel will also enable the carburetor float and inlet needle and seat assembly operation to be tested. Operate throttle lever several times and observe discharge from pump jets before installing carburetor.

(1) Ensure throttle body and intake manifold sealing surfaces are clean.

(2) Install manifold gasket on replacement carburetor.

(3) Place carburetor in position and loosely install attaching bolts and nuts.

(4) Install vacuum hoses and loosely connect fuel pipe fitting.

(5) Tighten attaching bolts and nuts with 145 inch-pounds (16 N•m) torque.

(6) Tighten fuel pipe fitting with 18 foot-pounds (24 N•m) torque.

(7) Connect throttle linkage and electrical connectors.

(8) Connect battery negative cable.

NOTE: Plug disconnected vacuum hoses.

WARNING: Use extreme caution when engine is operating. Do not stand in direct line with fan. Do not put hands near pulleys, belts or fan. Do not wear loose clothing.

(9) Adjust idle speed. Refer to Specifications.

(10) Install air cleaner, gasket and vacuum hoses.

CARBURETOR OVERHAUL

The following procedures apply to a complete overhaul with the carburetor removed from the engine.

A complete disassembly is not necessary for performing routine service adjustments. In most instances, service adjustments of the individual circuits can be performed without removing the carburetor from the engine. Refer to Service Adjustment Procedures.

A complete carburetor overhaul includes disassembly, thorough cleaning, inspection and replacement of the gaskets and worn or damaged parts. It also includes idle speed and mixture adjustment (if necessary) and fast idle adjustment after the carburetor is installed.

NOTE: When using an overhaul kit, use all parts included in the kit.

NOTE: Flooding, hesitation on acceleration, and other performance problems are in many instances caused by the presence of debris, water, or other foreign matter in the carburetor. To aid in diagnosing a problem, carefully remove the carburetor from the engine without removing the fuel from the bowl. Examine the bowl contents and filter for contamination as the carburetor is disassembled.

CAUTION: Before performing any service on the carburetor, it is essential that it be placed on a holding fixture. Without the use of the holding fixture, it is possible to damage the throttle valves.

Disassembly

(1) If clip is used to secure pump rod, remove clip and remove pump rod from hole in pump lever.

NOTE: Do not remove pump lever retaining screw, pump lever, and washer from air horn assembly.

(2) If clip is **not** used to secure pump rod (clipless design), remove pump lever retaining screw and washer from air horn (fig. 1J-67). Rotate pump lever to remove from pump rod.

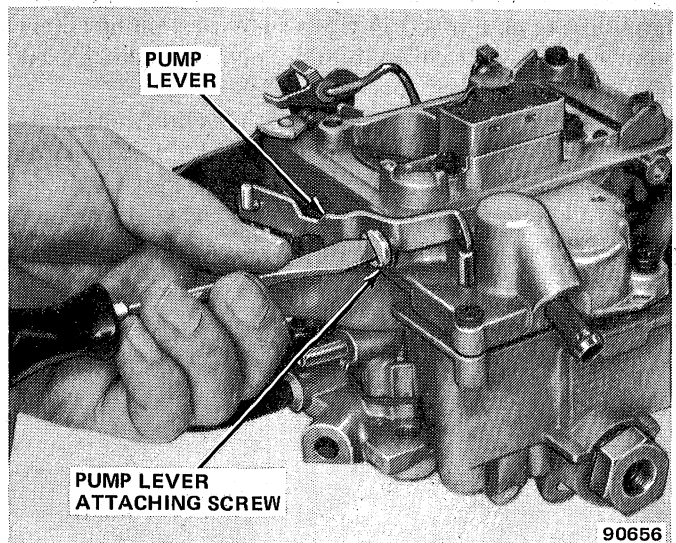

Fig. 1J-67 Carburetor Model E2SE—Pump Lever Screw Removal

(3) Remove hose from primary side vacuum break assembly and throttle body.

(4) Remove idle speed solenoid-vacuum break bracket attaching screws from air horn and throttle body (fig. 1J-68). Rotate vacuum break and bracket assembly to remove vacuum break rod and air valve rod from vacuum break diaphragm plunger. If not removed previously, remove idle speed solenoid from bracket.

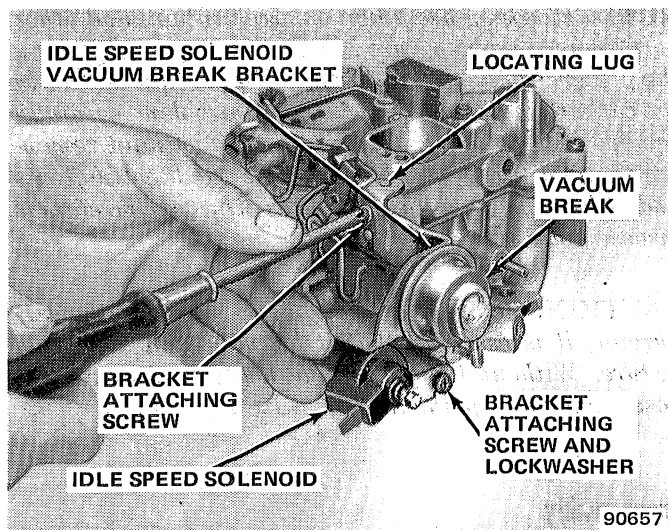

Fig. 1J-68 Carburetor Model E2SE—Vacuum Break Removal

CAUTION: Do not place vacuum break assembly and solenoid in carburetor cleaning solution. Immersion in solution will damage vacuum break diaphragm and solenoid.

(5) It is not necessary to remove the secondary side vacuum break rod from linkage unless replacement of vacuum rod is necessary. If necessary to replace secondary side vacuum break rod, remove and discard retaining clip from end of rod. A replacement retaining clip is required for reassembly. Remove plastic bushing used on rod and retain for reassembly.

(6) Remove and discard retaining clip from intermediate choke rod at choke lever (fig. 1J-69). A replacement retaining clip is required for reassembly. Remove choke rod and plastic bushing from choke lever and retain bushing for reassembly.

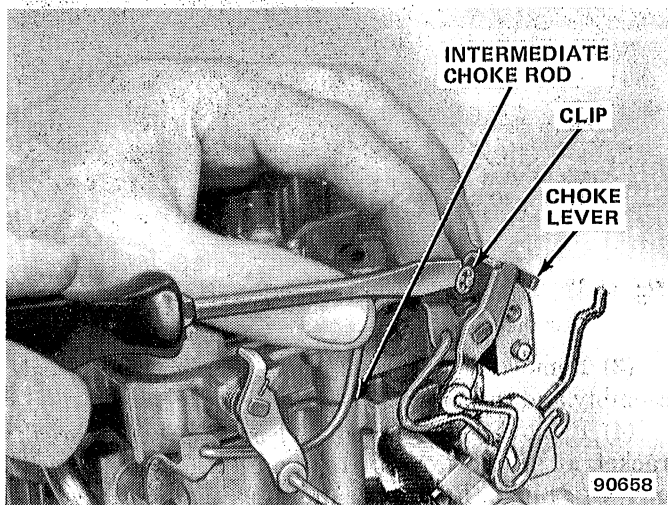

Fig. 1J-69 Carburetor Model E2SE—Intermediate Choke Rod and Clip Removal

(7) Remove three mixture control solenoid screws in air horn. Using slight twisting motion, carefully lift solenoid out of air horn (fig. 1J-70). Remove and discard solenoid gasket.

(8) Remove seal retainer and rubber seal from end of solenoid plunger. Do not damage or nick end of solenoid plunger. Discard seal and retainer.

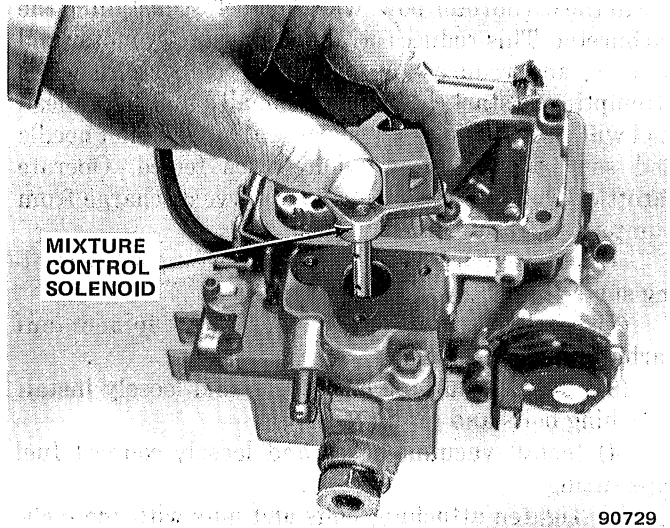

Fig. 1J-70 Carburetor Model E2SE—Mixture Control Solenoid Removal

(9) If equipped, remove two small screws that retain hot idle compensator valve (fig. 1J-71). Remove valve and seal from air horn. Discard seal. Hot idle compensator valve must be removed to gain access to short air horn-to-bowl attaching screw.

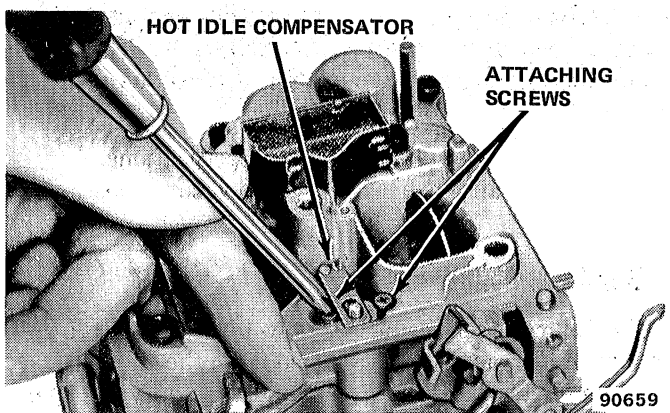
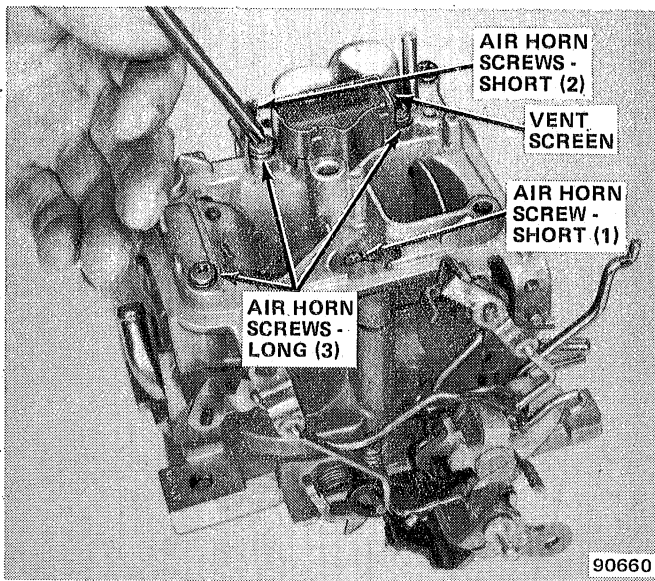

Fig. 1J-71 Carburetor Model E2SE—Hot Idle Compensator Valve Removal

(10) Remove six air horn-to-bowl attaching screws and lockwashers (fig. 1J-72).

(11) Rotate fast idle cam to full UP position and remove air horn assembly by tilting to disengage fast idle cam rod from slot in fast idle cam (fig. 1J-73). Air horn gasket should remain on float bowl for removal later. Do not remove fast idle cam screw and cam from float bowl.



**Fig. 1J-72 Carburetor Model E2SE—
Air Horn Screws and Vent Screen**

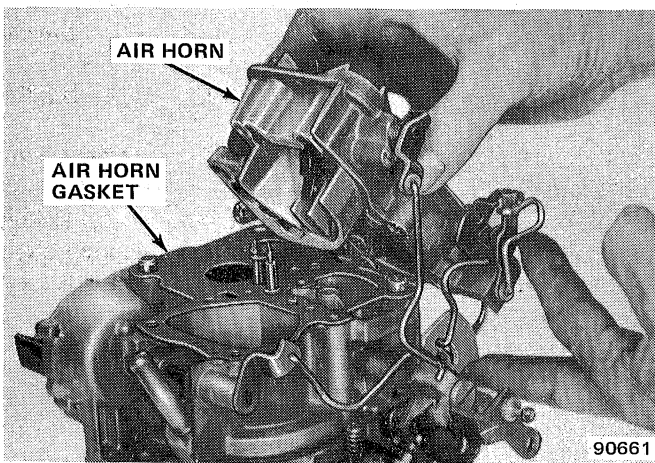

Fig. 1J-73 Carburetor Model E2SE—Air Horn Removal

NOTE: These parts are not serviced separately and are to remain permanently in place as installed during original assembly. The new service replacement float bowl will include the secondary lockout lever, fast idle cam and screw installed as required.

(12) Remove fast idle cam rod from choke lever by rotating rod to align tang on rod with small slot in lever.

(13) If necessary, remove two small screws and remove vent/screen assembly.

(14) Further disassembly of air horn is not required for cleaning purposes. If component replacement is required, remove staking on two choke valve attaching screws. Remove screws, choke valve, and shaft from air horn.

NOTE: The air valve screws are permanently staked in place and should not be removed. Do not attempt to remove the secondary metering rod from the air valve

assembly. Also, do not remove the plugs covering the idle air bleed screw during routine servicing. This adjustment screw is preset during original assembly and no attempt should be made to change the adjustment in the field except during air horn or float bowl replacement, at which time service instructions must be followed carefully. If air horn replacement is required during carburetor service, the new service air horn assembly will include the secondary metering rod-air valve assembly preset as required.

(15) It is not necessary to remove vacuum break rod, or air valve rod from levers in air horn unless replacement of rods is necessary. Plastic bushings on levers may be cleaned in carburetor cleaning solution.

NOTE: If necessary to replace the vacuum break rod, or air valve rod, remove and discard retaining clips from end of rods. Replacement retaining clips are required for reassembly. Remove plastic bushing used on rods and retain for reassembly.

(16) Remove pump plunger from pump well.

(17) Remove pump return spring from pump well.

(18) Remove plastic filler block located over float valve.

(19) Remove float assembly and float valve by pulling up on retaining pin. Remove float valve seat and gasket with Seat Remover Tool J-22769 (fig. 1J-74).

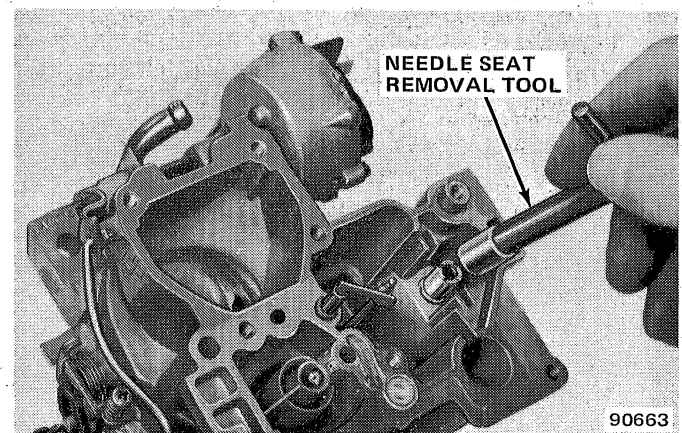
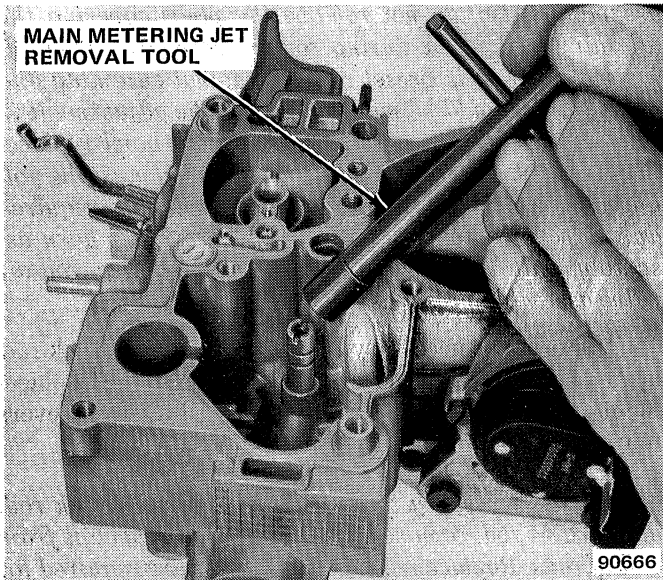

Fig. 1J-74 Carburetor Model E2SE—Inlet Needle Seat Removal

(20) With removal Tool J-22769 or a wide-blade screwdriver that fully fits slot in top of jet, remove extended main metering jet from float bowl (fig. 1J-75).

NOTE: Do not remove or change adjustment of the small calibration screw located deep inside the metering jet during routine servicing. The adjustment screw is preset during original assembly and no attempt should be made to change this adjustment in the field except during air horn or float bowl replacement, at which time service instructions must be followed carefully.

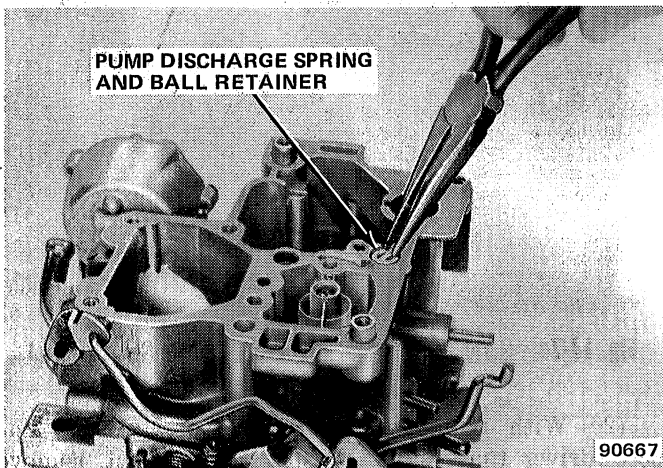

**Fig. 1J-75 Carburetor Model E2SE—
Extended Main Metering Jet Removal**

CAUTION: Do not attempt to remove plastic retainer by prying out with a tool such as a punch or screwdriver. This will damage the sealing beads on the bowl casting surface and necessitate complete float bowl replacement.

(21) Using needlenose pliers, or equivalent, remove plastic retainer holding pump discharge spring and check ball in place (fig. 1J-76). Discard plastic retainer (replacement retainer is required for reassembly).

(22) Turn bowl upside down and catch pump discharge spring and check ball in palm of hand.



**Fig. 1J-76 Carburetor Model E2SE—
Pump Discharge Retainer Removal**

NOTE: The tamper-resistant choke cover design is used to discourage indiscriminate readjustment of the choke cover and coil assembly in the field. However, it is necessary to remove the cover and coil assembly during normal carburetor disassembly for cleaning and overhaul.

(23) With small chisel and hammer, carefully cut off each rivet head (fig. 1J-77). Use a drift and small hammer to drive remainder of rivets out of choke housing. Use care to prevent damage to choke cover and housing.

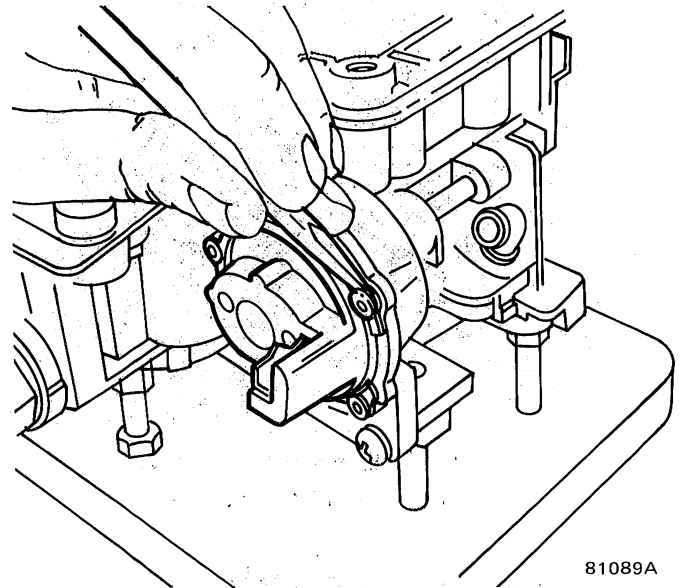

Fig. 1J-77 Carburetor Model E2SE—Choke Cover Rivets Removal

(24) Remove three retainers and choke cover assembly from choke housing.

(25) Remove screw from end of intermediate choke shaft inside choke housing (fig. 1J-78). Remove choke coil lever from shaft.

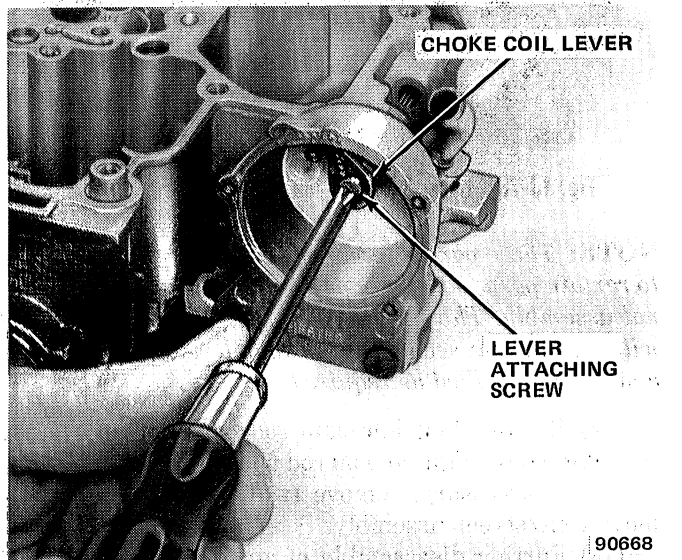
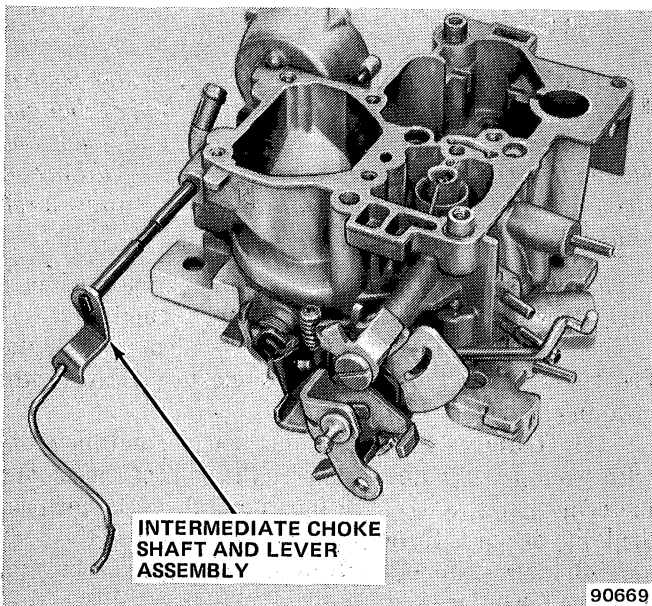

Fig. 1J-78 Carburetor Model E2SE—Choke Coil Lever Removal

(26) Remove intermediate choke shaft and lever assembly from float bowl by sliding rearward out throttle lever side (fig. 1J-79).

(27) Remove choke housing by removing two attaching screws in throttle body (fig. 1J-80).



**Fig. 1J-79 Carburetor Model E2SE—
Intermediate Choke Shaft Removal**

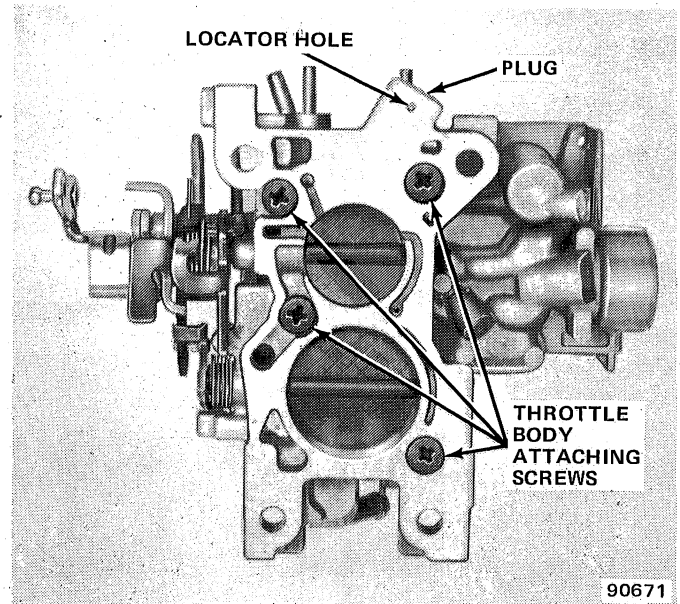

Fig. 1J-81 Carburetor Model E2SE—Throttle Body Screws

NOTE: *DO NOT* remove plug covering idle mixture adjustment screw unless it is necessary to replace it or normal soaking and air pressure fail to clean the idle mixture passages.

(34) Remove idle mixture plug and screw as follows:

(a) Invert throttle body and place on carburetor holding fixture—manifold side up.

(b) Place a punch in locator hole in throttle body beneath idle mixture screw plug (manifold side). Refer to figure 1J-83 for locating hole. Holding punch vertical, drive punch through locator until hardened steel plug breaks. Holding punch at 45 degree angle, break out throttle body casting to gain access to mixture screw plug. Drive out plug.

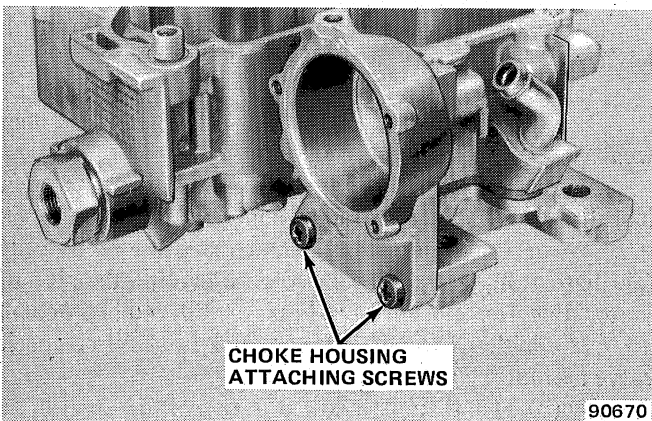

Fig. 1J-80 Carburetor Model E2SE—Choke Housing Screws

(28) Remove fuel inlet fitting, gasket, check valve/filter assembly, and spring.

(29) Remove four throttle body-to-bowl attaching screws and lockwashers and remove throttle body assembly (fig. 1J-81).

(30) Remove throttle body-to-bowl insulator gasket.

(31) Hold primary throttle lever wide-open and disengage pump rod from throttle lever by rotating rod until tang on rod aligns with slot in lever.

(32) If replacement is necessary, remove fast idle adjustment screw and clip in primary throttle lever.

(33) If required, remove curb or base idle speed adjustment screw and spring from throttle body.

NOTE: *Further disassembly of the throttle body is not required for cleaning purposes. The primary and secondary throttle valve screws are permanently staked in place and should not be removed. The throttle body is serviced as a complete assembly (fig. 1J-82).*

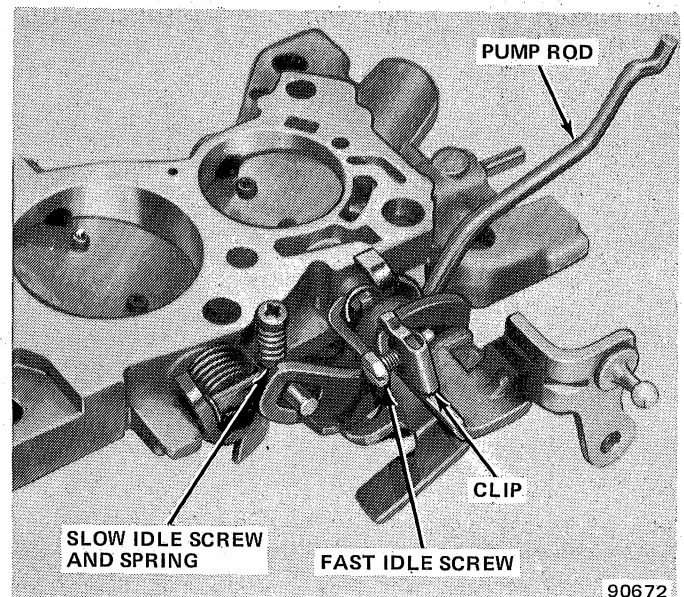
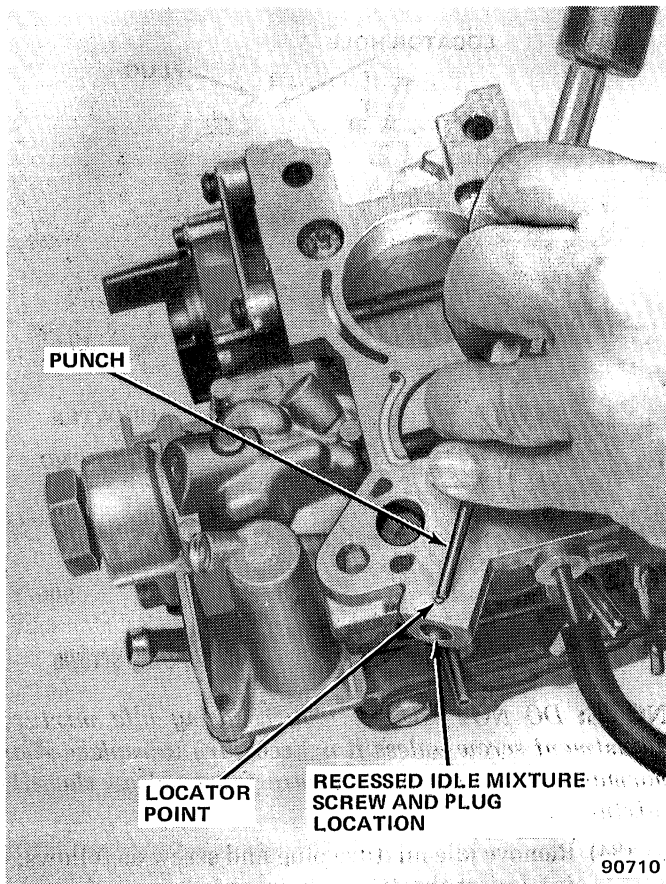

Fig. 1J-82 Carburetor Model E2SE—Throttle Body Assembly



**Fig. 1J-83 Carburetor Model E2SE—
Idle Mixture Screw Plug Removal**

NOTE: *The hardened plug will break rather than remain intact. It is not necessary to remove the plug completely; instead, remove loose pieces to allow use of Idle Mixture Adjusting Tool J-29030, or equivalent.*

(c) Using Tool J-29030, or equivalent, remove idle mixture screw and spring from throttle body (fig. 1J-84).

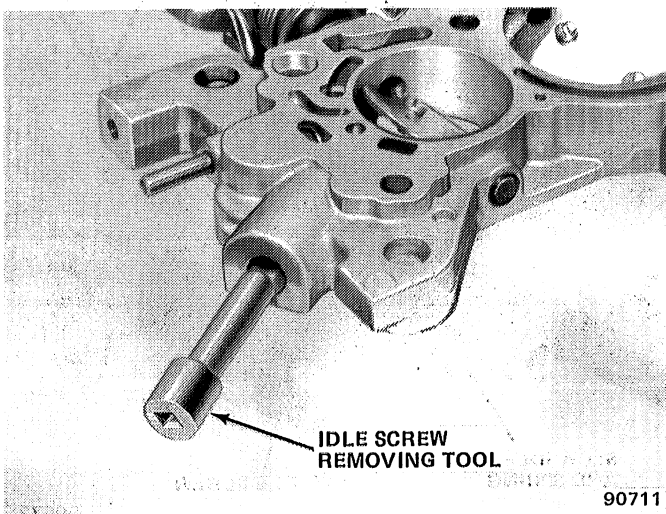

Fig. 1J-84 Carburetor Model E2SE—Idle Mixture Screw Removal

Cleaning and Inspection

CAUTION: *The idle speed solenoid, mixture control solenoid, electrically heated choke assembly, rubber and plastic components, diaphragms, pump plunger and plastic filler block must NOT be immersed in carburetor cleaning solution because they will either harden, swell or distort.*

The carburetor components should be cleaned in a cold immersion-type carburetor cleaning solution.

The plastic bushings located on the end of the vacuum break rod and air valve rod may be cleaned in carburetor cleaning solution.

(1) Thoroughly clean all metal parts and blow dry with compressed air. Ensure all fuel passages and metering parts are free of burrs and dirt. Do not pass drill bits or wires through jets and passages.

(2) Inspect upper and lower surface of carburetor castings for damage.

(3) Inspect holes in levers for excessive wear or out of round conditions. If worn, levers should be replaced. Inspect plastic bushings on levers for damage and excessive wear. Replace as required.

(4) Inspect, repair, or replace indicated parts if following problems have been encountered.

(a) Flooding:

1. Inspect float valve and seat for dirt, deep wear grooves, scores and proper seating.

2. Inspect float valve pull clip for proper installation (fig. 1J-85). Do not bend pull clip.

3. Inspect float, float arms and hinge pin for distortion, binds and burrs. Determine density of material in float; if heavier than normal, replace float.

4. Clean or replace fuel inlet filter-check valve assembly.

(b) Hesitation:

1. Inspect pump plunger for cracks, scores or excessively worn cup. A previously used pump cup will shrink when dry. If dried out, soak in fuel for eight hours before testing.

2. Inspect pump duration and return springs for weakness or distortion.

3. Examine all pump passages and jet for debris, improper seating of discharge check ball and scores in pump well. Examine condition of pump discharge check ball spring.

4. Inspect pump linkage for excessive wear; repair or replace as necessary.

(c) Hard Starting—Poor Cold Engine Operation:

1. Examine choke valve and linkage for excessive wear, binding or distortion.

2. Inspect choke vacuum diaphragm(s) for leaks.

3. Clean or replace carburetor fuel filter.

4. Inspect float valve for sticking condition, debris, etc.

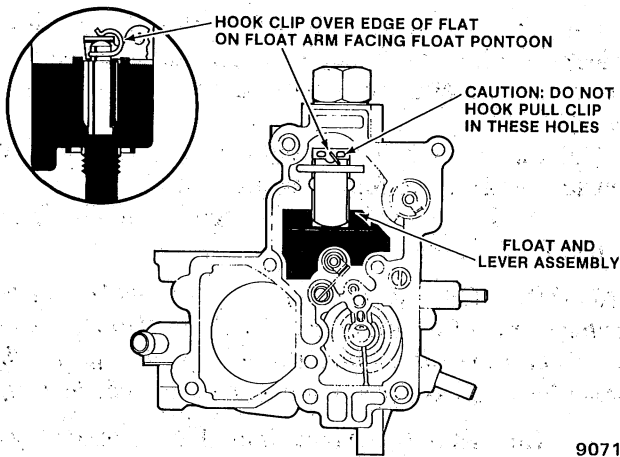

Fig. 1J-85 Carburetor Model E2SE—Float Valve Pull Clip

5. Also inspect items listed under Flooding (4a) above.

(d) Poor Engine Performance—Poor Fuel Economy:

1. Clean all fuel and vacuum passages in castings.
2. Inspect choke valve for freedom of movement.

CAUTION: DO NOT attempt to readjust the lean mixture screw located inside the extended main metering jet during routine servicing. The screw is adjusted during carburetor flow testing and misadjustment can affect carburetor calibration.

3. Inspect main metering jet for debris, looseness or damage.

4. Inspect air valve and secondary metering rod for binding condition. If air valve or metering rod is damaged or metering rod adjustment has been changed from original factory assembly setting, air horn assembly must be replaced.

5. Examine mixture control solenoid for sticking condition, binding or leakage. Refer to testing procedure listed below.

(e) Rough Idle:

1. Inspect gasket and gasket mating surfaces on castings for damage to sealing beads, nicks, burrs and other defects.

2. Clean all idle fuel passages.

3. If removed, inspect idle mixture screw for ridges, burrs or being bent.

4. Inspect throttle lever and valves for binding, nicks and other damage.

5. Examine all diaphragms for possible ruptures or leaks.

CAUTION: Clean plastic parts only in a low volatile cleaning solvent—never in gasoline.

Testing Mixture Control (MC) Solenoid

If the mixture control solenoid is suspected of either sticking, binding or leaking, test according to the following procedure (fig. 1J-86).

(1) Connect one end of jumper wire to either terminal of MC solenoid connector and other end to positive (+) terminal of 12 volt battery source.

(2) Connect one end of second jumper wire to other terminal of MC solenoid connector and other end to known good ground.

(3) With rubber seal and retainer removed from end of MC solenoid stem, attach hose from hand vacuum pump.

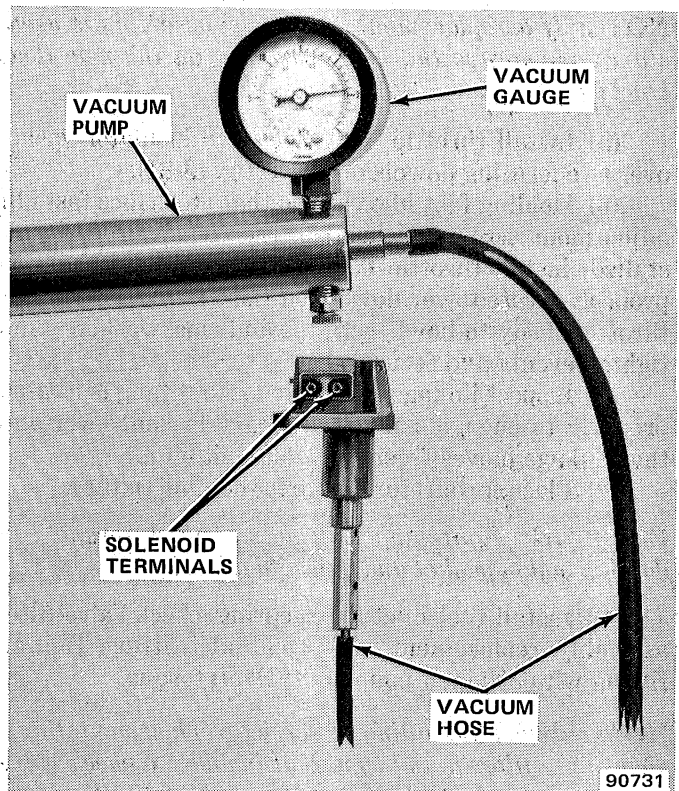

Fig. 1J-86 Carburetor Model E2SE—Testing Mixture Control Solenoid

(4) With MC solenoid energized (lean position), apply at least 25 in. Hg (84 kPa) of vacuum and time leak-down rate from 20 in. Hg (67 kPa) to 15 in. Hg (51 kPa). Leak-down rate should not exceed 5 in. Hg (17 kPa) in 5 seconds. If leakage exceeds that amount, replace MC solenoid.

(5) To test solenoid for sticking in down (de-energized) position, remove jumper wire connected to 12 volt source and observe hand vacuum pump gauge pointer. It should move to zero in less than one second. If not, replace MC solenoid.

Assembly

CAUTION: Place throttle body assembly on carburetor holding fixture to avoid damaging throttle valves.

(1) Install curb or base idle speed adjustment screw and spring, if removed, in throttle body (fig. 1J-82).

(2) If removed, install fast idle adjustment screw and clip in primary throttle lever (fig. 1J-82).

(3) Holding primary throttle lever wide open, install lower end of pump rod in throttle lever by aligning tang on rod with slot in lever. End of rod should point outward toward throttle lever.

(4) If removed, install idle mixture adjustment screw and spring with Tool J-29030 (fig. 1J-84). Lightly seat screw and then back out three turns for a preliminary idle mixture adjustment. Final idle mixture adjustment must be performed with carburetor installed on engine.

NOTE: If a replacement float bowl assembly is used, stamp or engrave the model number on the new float bowl (fig. 1J-59).

(5) Install throttle body and bowl insulator gasket over two locating dowels on bowl (fig. 1J-81).

(6) Holding fast idle cam so that steps face fast idle adjustment screw on throttle lever when properly installed, install throttle body ensuring throttle body is properly located over dowels on float bowl. Install four throttle body-to-bowl screws and lockwashers and tighten evenly and securely.

(7) Inspect linkage to ensure lockout tang is located properly to engage slot in secondary lockout lever and that linkage moves freely and does not bind.

(8) Place carburetor on proper holding fixture.

CAUTION: Tightening beyond specified torque can damage nylon gasket and cause fuel leak.

(9) Install fuel inlet filter spring, check valve-filter assembly, replacement gasket and inlet fitting. Tighten fitting with 300 inch-pounds (34 N•m) torque.

NOTE: When installing a service replacement filter, ensure the filter is the type that includes a check valve that conforms to U.S. Motor Vehicle Safety Standards (M.V.S.S.).

NOTE: When properly installed, hole in filter faces toward inlet fitting. Ribs on closed end of filter element prevent filter from being installed incorrectly unless forced.

(10) Install choke housing on throttle body. Ensure raised boss and locating lug on rear of housing fit into recesses in float bowl casting (fig. 1J-80). Install two choke housing attaching screws and lockwashers in throttle body and tighten screws evenly and securely.

(11) Install intermediate choke shaft and lever assembly in float bowl by pushing through from throttle lever side (fig. 1J-79).

(12) With intermediate choke lever in UP (12 o'clock) position, install bimetallic coil lever inside choke housing onto flats on intermediate choke shaft. Coil lever is

properly aligned when coil pickup tang is at top (12 o'clock) position (fig. 1J-87). Install inside lever retaining screw into end of intermediate choke shaft and tighten securely.

(13) Install choke cover and coil assembly on choke housing according to following procedure.

(a) Place fast idle adjustment screw on highest step of fast idle cam.

CAUTION: Ground contact for the choke electric heater is provided by a metal plate located at the rear of the choke cover assembly. Do not install a gasket between the choke cover assembly and the choke housing.

(b) Install cover and bimetallic coil assembly on choke housing. Align notch in cover with raised casting projection on housing cover flange. Ensure coil pickup tang engages inside choke coil lever.

(c) Install three cover retainers and rivets.

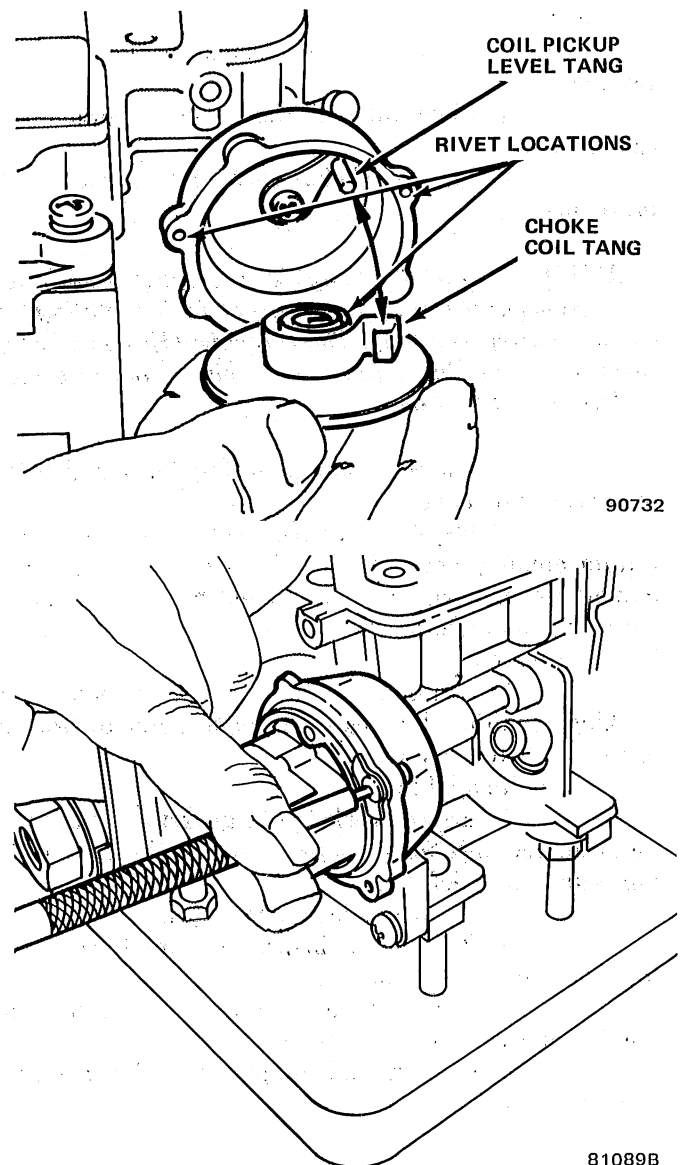

90732

81089B

Fig. 1J-87 Carburetor Model E2SE—Choke Coil and Cover Installation

(14) Install pump discharge steel check valve ball and spring in passage next to float chamber. Insert end of replacement plastic retainer into end of spring and install retainer in float bowl. Tap lightly in place until top of retainer is flush with bowl casting surface.

(15) Using Tool J-22769 or a screwdriver that fully fits slot in top, install extended main metering jet into bottom of float chamber. Tighten jet securely.

(16) Install inlet needle seat assembly, with gasket, using Seat Installer Tool J-22769 (fig. 1J-74).

(17) For easier adjustment, carefully bend float arm upward at notch in arm before assembly.

(18) Install float valve onto float arm by sliding float lever under pull clip. Correct installation of pull clip is to hook clip over edge of float on float arm facing float pontoon (fig. 1J-85).

(19) Install float retaining pin into float arm with end of loop of pin facing pump well. Install float assembly by aligning valve in seat and float retaining pin into locating channels in float bowl.

(20) Adjust float level:

(a) Refer to figure 1J-88. Hold float retaining pin firmly in place and push down lightly on float arm at outer end against top of float valve.

(b) Using adjustable "T" scale, measure from top of float bowl casting surface (air horn gasket removed) to top of float at toe. Measuring point is 3/16 inch back from end of float at toe.

(c) Bend float arm as necessary for proper adjustment by pushing on pontoon (refer to Specifications).

(d) Visually inspect float alignment after adjustment.

(21) Install plastic filler block over float valve by pressing downward until properly seated (flush with bowl casting surface).

(22) Install air horn gasket on float bowl. Locate gasket over two dowel locating pins on bowl.

(23) Install pump return spring in pump well.

(24) Install pump plunger assembly in pump well.

(25) If removed, install vent/screen assembly and two small attaching screws. Tighten screws securely.

CAUTION: Test choke valve for freedom of movement and proper alignment before staking screws in place.

(26) If removed, install choke shaft, choke valve, and two attaching screws. Tighten screws securely and stake lightly in place.

(27) If used, install new pump plunger stem seal and retainer in air horn casting. Lightly stake seal retainer in three places. Choose locations that are different from original staking positions.

(28) Install fast idle cam rod in lower hole of choke lever. Align tang on rod with small slot in lever.

(29) If removed, install plastic bushing in hole in vacuum break lever. Ensure small end of bushing faces retaining clip when installed. Insert end of vacuum break rod through bushing in lever. Retain rod with replacement clip. Press clip in place using needlenose pliers. Ensure clip has full contact on rod but is not seated tightly against bushing. Rod-to-bushing clearance should be 0.030 inch (0.8 mm). Retaining clip is "dished." Install clip on rod with outward bend of self-locking clip facing end of rod. Ensure that clip fully engages rod and that it is not distorted.

(30) If removed, install plastic bushing in hole in air valve lever. Ensure small end of bushing faces retaining clip when installed. Insert end of air valve rod through bushing in lever. Retain with replacement clip. Press clip in place with needlenose pliers. Ensure clip has full contact on rod but is not seated tightly against bushing. Rod-to-bushing clearance should be 0.030 inch (0.8 mm). Retaining clip is "dished." Install clip on rod with outward bend of self-locking clip facing end of rod. Ensure that clip fully engages rod and that it is not distorted.

(31) Prior to installing air horn on float bowl, apply a light coat of silicone grease or light weight engine oil to stem on pump plunger in bowl to aid insertion of stem through seal on air horn.

CAUTION: Do not force air horn assembly onto bowl, gently lower in place.

(32) Rotate fast idle cam to full UP position and tilt air horn assembly to engage lower end of fast idle cam rod in slot in fast idle cam. Holding down on pump plunger assembly, carefully lower air horn assembly onto float bowl. Guide pump plunger stem through seal in air horn casting.

(33) Install six air horn to bowl attaching screws and lockwashers. Three long air horn screws are located in primary and secondary venturi area. Two short screws are located on fuel inlet side and one short screw is located in area beneath hot idle compensator valve. All

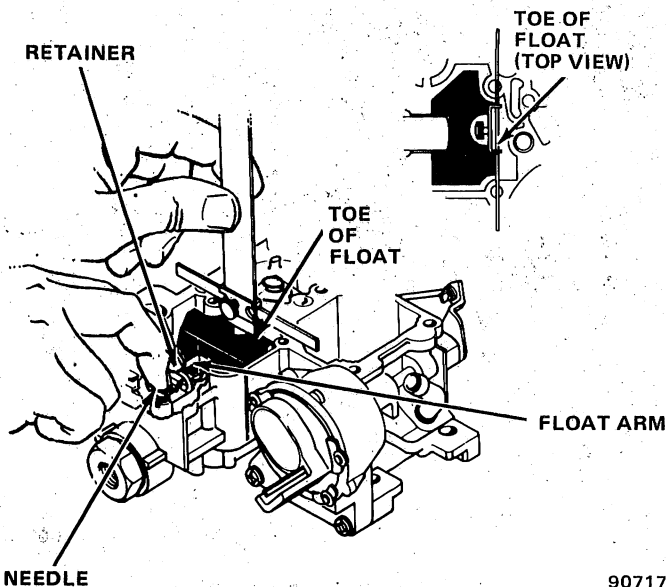

90717

Fig. 1J-88 Carburetor Model E2SE—Float Level Adjustment

air horn screws must be tightened evenly and securely. Refer to figure 1J-89 for proper tightening sequence.

(34) If equipped, install replacement seal in recess of float bowl. Install hot idle compensator valve and retain with two small attaching screws. Tighten screws securely.

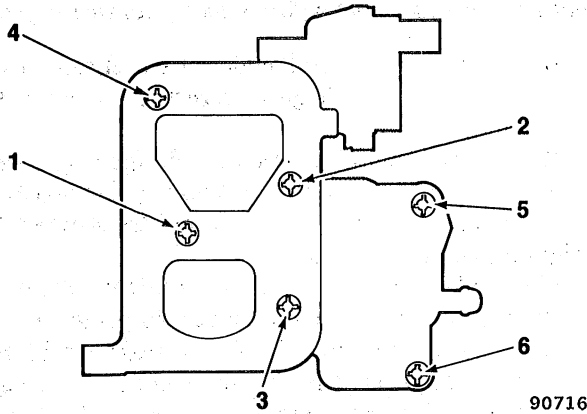

Fig. 1J-89 Carburetor Model E2SE—
Air Horn Screw Tightening Sequence

(35) If not tested previously, test mixture control solenoid for sticking, binding and leakage following procedure listed within Cleaning and Inspection. Install replacement rubber seal on mixture control solenoid stem. Position seal up against boss on solenoid stem. Using 3/16-inch socket and small hammer, carefully drive retainer on stem (fig. 1J-90). Drive retainer on stem only far enough to retain rubber seal on stem. Leave small clearance between retainer and seal to allow for seal expansion.

CAUTION: A slight twisting motion of the solenoid is required during installation to ensure rubber seal on stem is guided into recess in the bottom of the bowl and to prevent distortion or damage to the rubber seal.

(36) Prior to installing mixture control solenoid, lightly coat rubber seal on end of solenoid stem with silicone grease or light weight engine oil. With replacement mounting gasket, install mixture control solenoid on air horn. Carefully align solenoid stem with recess in bottom of bowl (fig. 1J-91).

(37) Install three solenoid attaching screws and tighten securely.

(38) Install plastic bushing in hole in choke lever. Ensure small end of bushing faces retaining clip when installed.

(39) With inner coil lever and intermediate choke lever at 12 o'clock position, install intermediate choke rod in bushing. Retain rod with replacement clip. Press clip securely in place with needlenose pliers. Ensure clip has full contact on rod but is not seated tightly against bushing. Rod-to-bushing clearance should be 0.030 inch

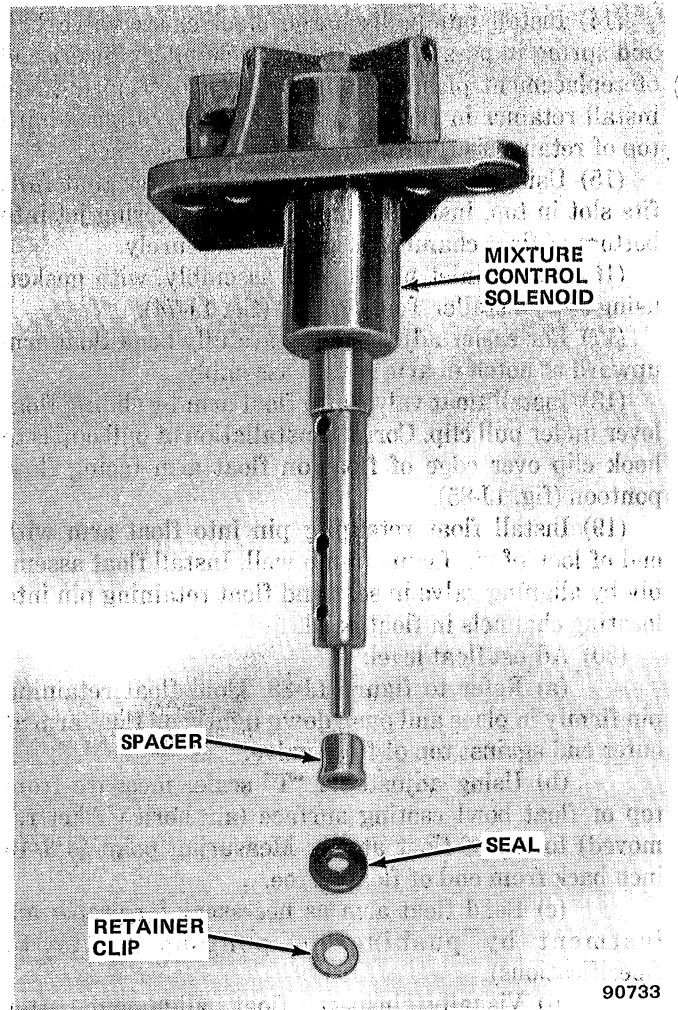

Fig. 1J-90 Carburetor Model E2SE—
Mixture Control Solenoid Seal and Retainer

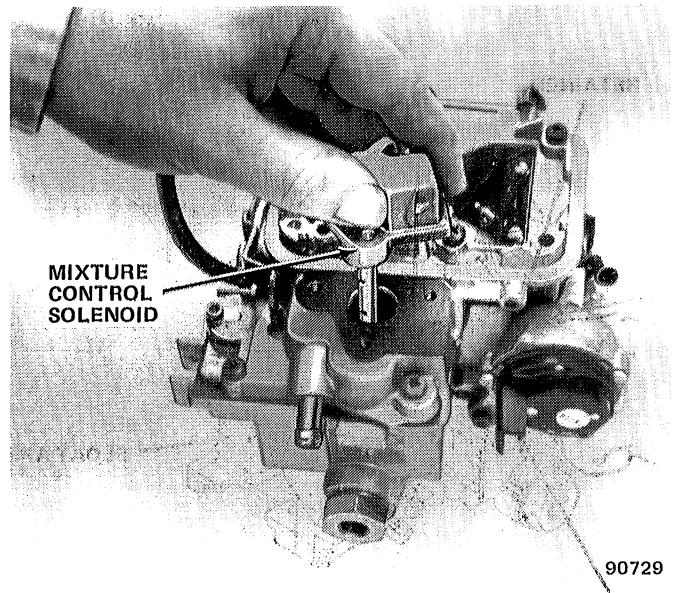

Fig. 1J-91 Carburetor Model E2SE—
Installing Mixture Control Solenoid

(0.8 mm). Retaining clip is "dished." Install clip on rod with outward bend of self-locking clip facing end of rod. Ensure that clip fully engages rod and that it is not distorted.

CAUTION: Use care when tightening idle speed solenoid retaining nut with wrench to avoid damaging vacuum break plunger.

(40) If removed, install idle speed solenoid, lockwasher and retaining nut on primary side vacuum bracket. Tighten nut securely. Bend back two retaining tabs on lockwasher to fit in slots in bracket.

(41) Rotate vacuum break bracket and insert end of vacuum break rod into inner slot of vacuum break diaphragm plunger and end of air valve rod into outer slot of vacuum break diaphragm plunger. Install bracket over locating lugs on air horn with taper-seat screw in air horn and screw with lockwasher in throttle body. Tighten screws securely.

(42) Insert pump rod in hole in pump lever by rotating lever. Install retaining screw in pump lever, then install washer. Holding down on pump plunger stem, install pump lever on air horn. Ensure shoulder on screw seats in hole in lever and washer is between lever and air horn casting. Tighten screw securely.

SERVICE ADJUSTMENT PROCEDURES

Refer to Service Adjustment Procedures within Model 2SE Carburetor section and to General Service and Diagnosis—Chapter 1A.

Float Level Measurement

NOTE: The float level should be determined before disassembling a carburetor for overhaul if a malfunctioning float is suspected of affecting engine performance.

NOTE: The fuel level in the carburetor bowl can be affected by fuel pump pressure as well as by an improperly adjusted float.

To determine if the float requires adjustment, measure the float level according to the following procedure.

(1) Remove vent stack screws and vent stack.

(2) Remove air horn screw located adjacent to vent stack.

WARNING: Use extreme caution when engine is operating. Do not stand in direct line with fan. Do not put hands near pulleys, belts or fan. Do not wear loose clothing.

(3) With engine at idle speed and choke valve completely open, carefully insert float gauge in air horn

screw hole and vent hole. Allow gauge to rest freely on float.

NOTE: Use Gauge J-9789-136 (white) for model E2SE carburetor.

CAUTION: Do not press down on gauge because engine may flood or float may be damaged.

(4) With gauge at eye level observe mark on gauge that aligns with top of casting at vent hole. Float level should be within ± 1.5 mm (± 0.06 inch) of float level specification. Refer to Specifications.

(5) Remove float gauge.

(6) If float level is not within specification, remove carburetor air horn and adjust float level. Refer to Float Level Adjustment.

(7) If float level is within specification, install air horn screw, vent stack and vent stack screws.

Idle Speed Adjustments

The engine and related systems must be performing properly before initiating the idle speed adjustments.

Precautions and General Information.

- Place manual transmission in neutral. Set the parking brake firmly and do not accelerate the engine.
- Ensure the engine is at normal operating temperature before adjusting the idle speed.
- Perform the procedure with the air cleaner installed or with air cleaner removed and associated vacuum hoses plugged, choke open and deceleration valve supply hose plugged.
- Do not idle the engine more than three minutes at a time.
- If the idle speed adjustment procedure requires more than three minutes, operate the engine at 2000 rpm for one minute.
- Ensure the ignition timing is correct before adjusting idle speed.
- Use extreme caution around fan, belts and other moving parts when the engine is operating. Do not wear loose clothing. Do not stand in direct line with the fan blades.

Slow (Curb) Idle Speed Adjustment Procedure

(1) Disconnect and plug purge vacuum hose at vapor canister.

(2) Connect dwell meter to single light blue wire taped to mixture control solenoid wires at carburetor. Set dwell meter on "6-cylinder" scale. Connect tachometer at distributor side of filter.

NOTE: Use a tachometer with an expanded scale of 400 to 800 or 0 to 1000 rpm. Inspect tachometer periodically to ensure accuracy within two percent.

(3) Set parking brake firmly. Manual transmission in neutral position.

WARNING: Use extreme caution when engine is operating. Do not stand in direct line with fan. Do not put hands near pulleys, belts or fan. Do not wear loose clothing.

(4) Start engine and warm to normal operating temperature. Dwell meter pointer should now be oscillating. Pointer should be generally located between 10 and 50 degrees with maximum sweep of pointer oscillation covering a segment of 15 degrees. If not, refer to C4 System Operational Test.

(5) Open throttle momentarily to ensure idle speed solenoid is fully extended. Adjust idle speed by turning solenoid idle adjustment screw to obtain specified idle speed. Refer to Specifications.

(6) Disconnect solenoid wire. Adjust curb idle to 500 rpm.

(7) Connect solenoid wire.

(8) Stop engine. Disconnect and remove dwell meter and tachometer. Install air cleaner and connect vacuum hoses, if removed. Connect canister purge vacuum hose and deceleration valve supply hose.

Model E2SE Carburetor Idle Speed Adjustment Specifications

Transmission	RPM
Manual	900 (± 100) ①

① Idle speed with solenoid de-energized is 500 rpm. 90984

Fast Idle Speed Adjustment Procedure

(1) Connect tachometer at distributor side of filter.

(2) Set parking brake. Place manual transmission in neutral position.

WARNING: Use extreme caution when engine is operating. Do not stand in direct line with fan. Do not put hands near pulleys, belts or fan. Do not wear loose clothing.

(3) Start and warm engine to normal operating temperature.

(4) Disconnect and plug EGR valve vacuum hose.

(5) Open throttle slightly and rotate fast idle cam until screw is against highest step of cam.

(6) Adjust fast idle speed to specified rpm.

(7) Quickly open throttle slightly and allow engine to return to slow idle speed.

(8) Connect EGR valve vacuum hose.

Idle Mixture Adjustment

Refer to Carburetor Model E2SE Idle Mixture Adjustment procedure listed within Feedback System section.

Idle mixture adjustment should not normally be necessary; only after carburetor overhaul and if original mixture screw adjustment has been altered.

Choke Mechanism Service

Refer to Service Adjustment Procedures within Model 2SE Carburetor section.

SPECIFICATIONS

Model E2SE Carburetor Specifications

List Number	17082389
Pri. Throttle Bore	35 mm
Sec. Throttle Bore	46 mm
Pri. Venturi Diameter	28 mm
Sec. Venturi Diameter	Var. Air Valve
Fuel Inlet Seat Diameter	2.36 mm
Idle Bypass	1.78 mm
Idle Tube	0.80 mm
Side Idle Air Bleed	1.17 mm
Lower Idle Air Bleed	1.32 mm
Spark Port Size	1.14 mm
	x 3.84 mm
Main Jet	No. 4 (1.752 mm)
Pri. Metering Rod No.	N/A
Sec. Metering Rod No.	DX12905-37
Top Well Bleed	0.90 mm
Side Well Bleed	1.02 mm
Power Valve Timing	N/A
Accelerator Nozzle Diameter	0.50 mm

90736

4-Cylinder Engine	Carburetor Number	Float Level mm (Inches)	Pump Stem Height mm (Inches)	Fast Cam Adj. 2nd Step	Fast Idle Speed ±100 rpm	Air Valve Link ①	Vac. Break Pri.	Unloader	Choke	Secondary Lockout	Choke Coil Lever Plug Gauge
CJ (Calif. only)	Man. Trans. 17082389	4.3 (0.169)	3.25 (.128)	18°	2400	2°	19°	34°	TR	1.27-2.03 mm (.050-.080 in.)	1.27-2.03 mm (.050-.080 in.)

① Maximum Degree Setting TR Tamper Resistant

90736

CARBURETOR MODEL BBD-2 VENTURI

	Page		Page
Carburetor Circuits	1J-47	Idle Speed Control	1J-49
Carburetor Overhaul	1J-50	Service Adjustment Procedures	1J-55
Carburetor Replacement	1J-50	Specifications	1J-57
General	1J-46		

GENERAL

The Carter Model BBD two-venturi carburetor incorporates three lightweight aluminum assemblies, the air horn, main body and throttle body (fig. 1J-92).

The air horn contains the choke valve assembly, mechanical linkage for accelerator pump and metering rods, and bowl vent.

The main body contains the fuel bowl, accelerator pump, vacuum piston and metering rod assembly, venturi assembly and solenoid.

The throttle body contains throttle valves and levers, choke housing, choke vacuum diaphragm and idle mixture adjustment screws.

Identification

The carburetor is identified by a code number and build date. Both are stamped on the identification tag. Each carburetor build month is coded alphabetically beginning with the letter A in January and ending with the letter M in December (the letter I is not used). The tag is attached to the carburetor and must remain with the carburetor to assure proper identification (fig. 1J-93).

CARBURETOR CIRCUITS

Five conventional circuits are used:

- Float (fuel inlet)
- Idle (low speed) Metering
- Main (high speed) Metering
- Pump (acceleration)
- Choke

Float (Fuel Inlet) Circuit

The float circuit maintains the specified fuel level in the bowl to provide sufficient fuel to the metering circuits for all engine operating conditions (fig. 1J-94).

Fuel flows into the bowl through a needle and seat assembly controlled directly by dual floats hinged to the float fulcrum pin.

When the fuel in the bowl fills to the proper level, the float lever pushes the needle toward its seat and restricts incoming fuel, admitting only enough to replace that being used.

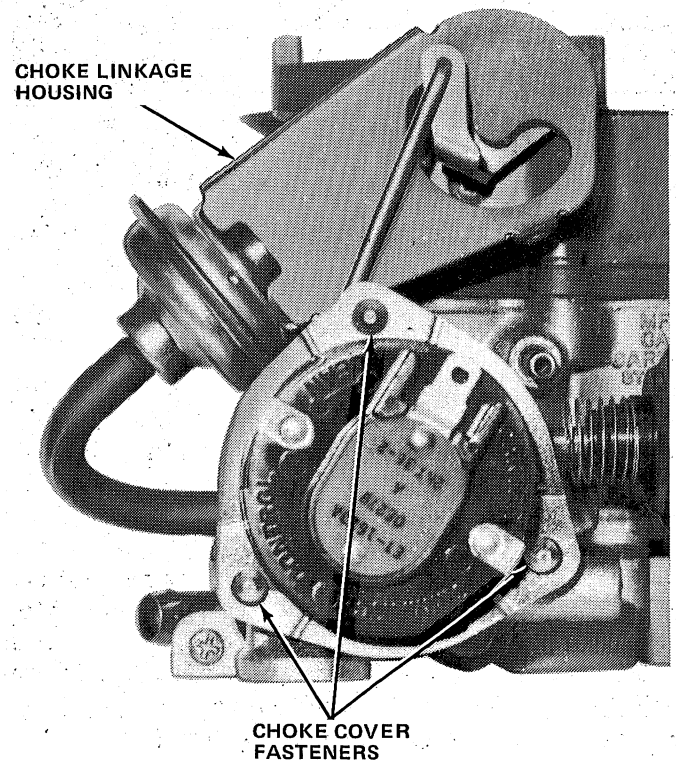
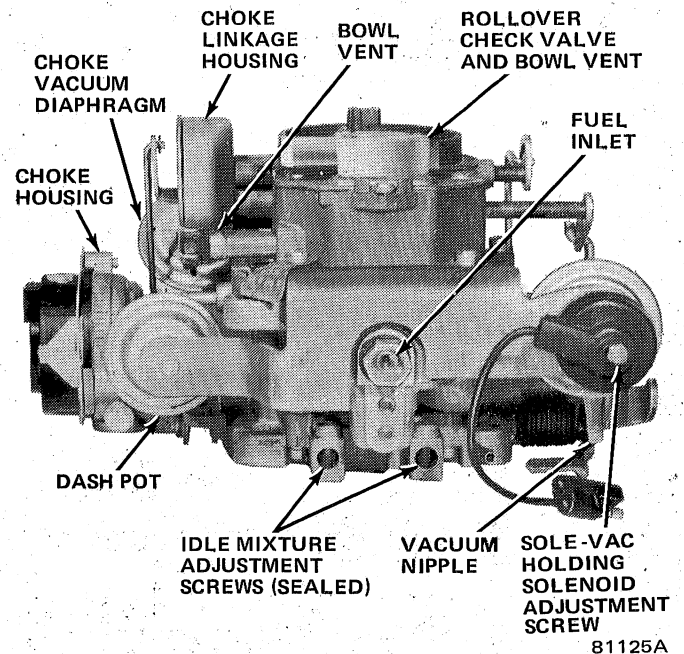

Fig. 1J-92 Model BBD Carburetor Assembly

81125C

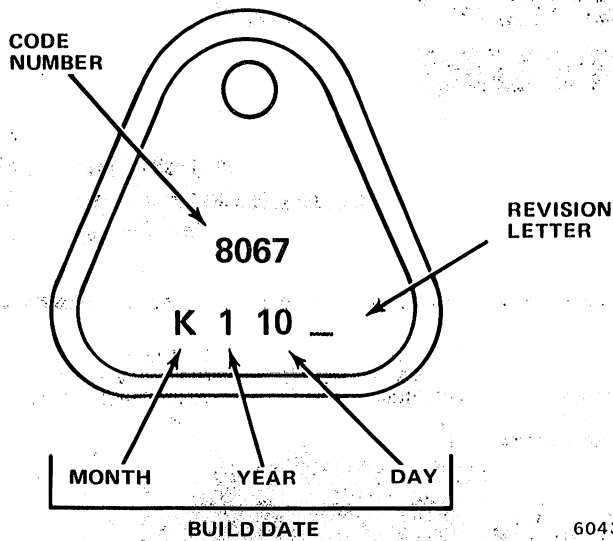

Fig. 1J-93 Identification Tag

Idle (Low Speed) Metering Circuit

Fuel for idle and initial part-throttle operation is metered through the idle circuit.

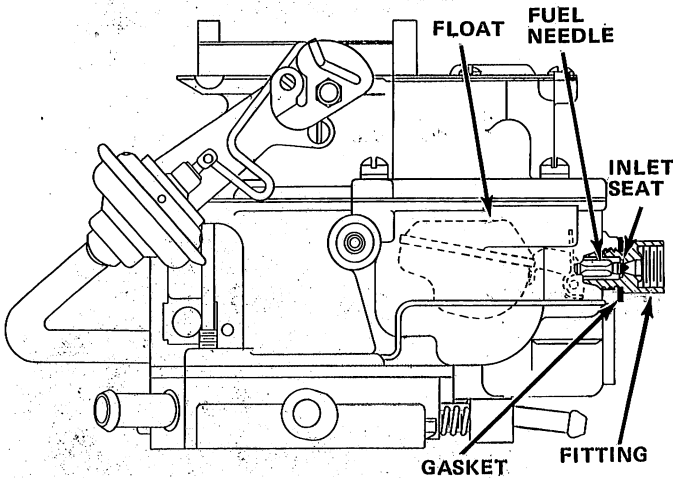

Fig. 1J-94 Float Circuit

Fuel flows through main metering jets into the main wells and continues through the idle fuel pickup tube where fuel mixes with air entering through idle air bleeds located in the venturi cluster screws (fig. 1J-95).

At curb idle speed, the air/fuel mixture flows down the idle channel and is further mixed with air entering the idle channel through the transfer slot, which is above the position of the throttle valve at curb idle speed. The mixture then flows past the idle mixture adjustment screw, which controls the volume of the mixture that is discharged below the throttle valve.

During low speed operation, the throttle valve moves to expose the transfer slot as well as the idle port. This

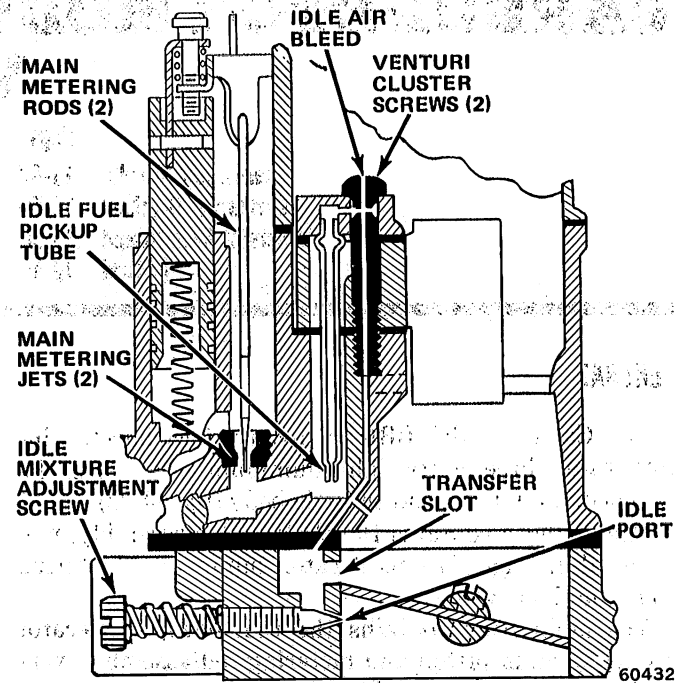

Fig. 1J-95 Idle Circuit

increased airflow creates a low pressure in the venturi and the main metering system begins to discharge fuel.

Main (High Speed) Metering Circuit

At partial throttle and cruising speed increased air flow through the venturi creates a low pressure area in the venturi. Because the air above the fuel in the bowl is at atmospheric pressure, fuel is forced to the lower pressure area that was created by the venturi and amplified by the booster venturi.

The fuel flow moves through the main jets to the main well. Air enters through the main well air bleeds. The resulting mixture of air and fuel is lighter than raw fuel, responds more quickly to changes in venturi vacuum, and is more readily vaporized when discharged into the venturi (fig. 1J-96).

Main Metering Circuit Enrichment

During heavy load or high speed operation, the air/fuel ratio must be enriched to provide increased engine power.

Fuel enrichment is accomplished by means of two calibrated metering rods connected to a single manifold vacuum actuated piston (fig. 1J-96). The metering rod piston rides on a calibrated spring that functions to maintain the piston at the top of its cylinder. This allows only the smallest diameter of the tapered metering rods to extend into the main metering jets and permits maximum fuel flow through the jets to the main well cavities.

At idle, partial throttle or cruise conditions when manifold vacuum is high, the piston is drawn down into

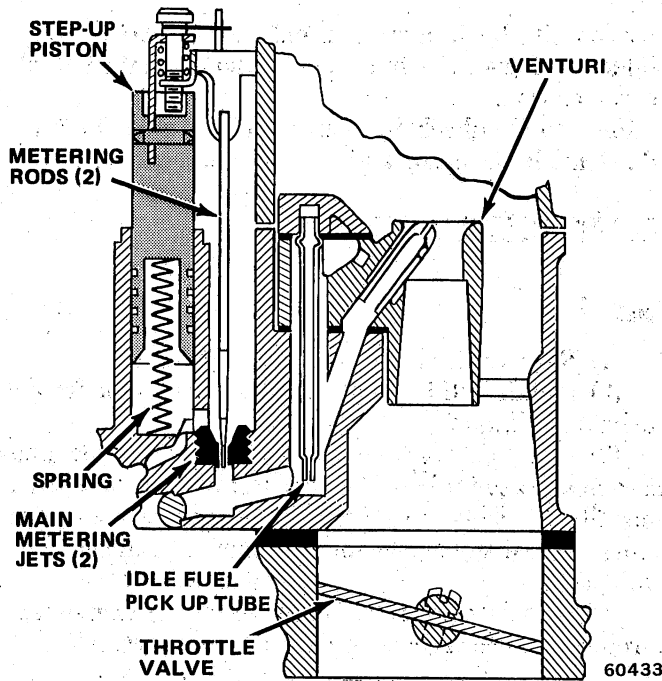

Fig. 1J-96 Main Metering Circuit

the vacuum cylinder against calibrated spring tension and the larger diameters of the metering rods extend into the main metering jets, restricting the fuel flow to the main well cavities. An additional control is provided by the rod lifter on the accelerator pump rod. This provides a direct relationship between metering rod position and throttle valve opening.

Pump (Acceleration) Circuit

When the throttle is opened suddenly, airflow response through the carburetor is almost immediate. There is a brief time lag before fuel inertia can be overcome. This lag causes the desired air/fuel ratio to be leaned out.

A piston-type accelerating pump system mechanically supplies the fuel necessary to compensate for this deficiency (fig. 1J-97).

Fuel is forced into the pump cylinder from the fuel bowl past the pump piston on the upward movement of the accelerator pump shaft. When the engine is turned off, fuel vapors in the pump cylinder vent through the area between the pump rod and pump piston.

As the throttle lever is moved, the pump link, operating through a system of levers and assisted by the pump drive spring, pushes the pump piston down. Fuel is forced through a passage, past the pump discharge check valve ball, and out the pump discharge jets in the venturi cluster.

Choke Circuit

The choke valve, located in the air horn assembly, provides a high vacuum both above and below the

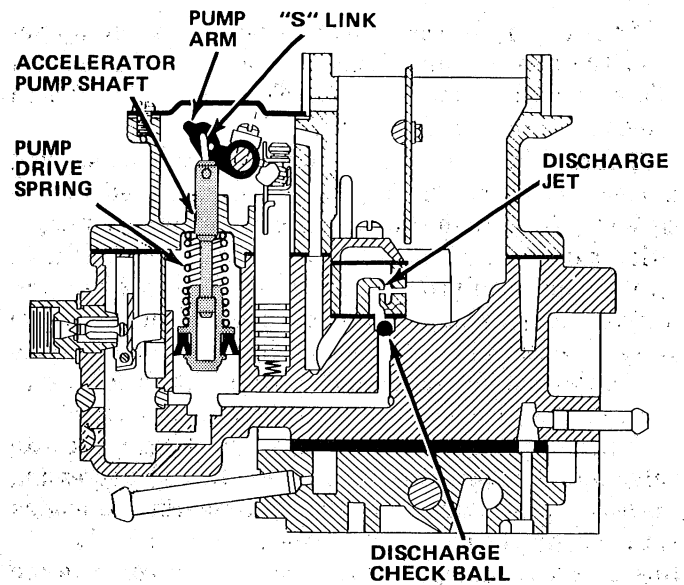

Fig. 1J-97 Pump Circuit

throttle valves when closed. During engine start, vacuum above the throttle valve causes fuel to flow from the main metering and idle circuits and provides the richer air/fuel mixture ratio needed for cold engine starting (fig. 1J-98).

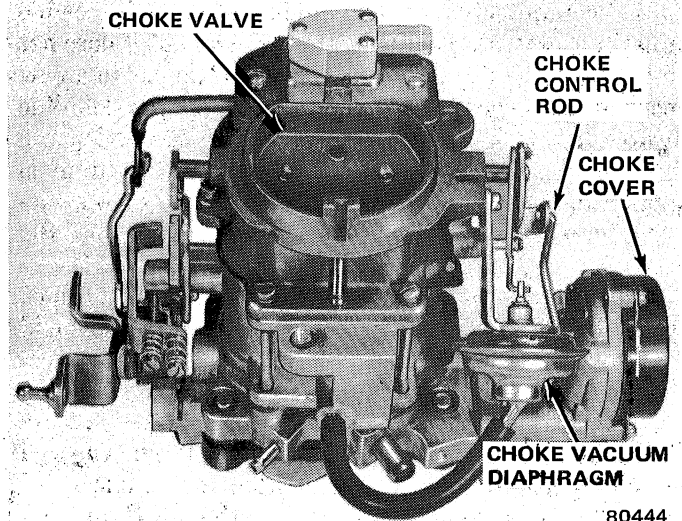

Fig. 1J-98 Choke Circuit Components

The choke shaft is connected by linkage to a bimetallic coil located within the choke cover, which winds up (contracts) when cold and unwinds (expands) when heated. When the engine is cold, the tension of the coil holds the choke valve closed. When the engine starts, manifold vacuum is applied to the diaphragm assembly to open the choke valve slightly. This is referred to as the initial choke valve clearance.

As the coil is warmed by the electric heater, it expands and exerts pressure to further open the choke valve, keeping it fully open at normal engine operating temperature.

If the engine is accelerated during the warm-up period, the corresponding drop in the manifold vacuum allows the coil to momentarily close the choke valve to provide a richer air/fuel mixture.

A faster idle speed is provided to prevent stalling during warm-up. The fast idle cam, actuated by the choke shaft through connecting linkage, rotates into position against the fast idle screw. The cam is progressively stepped to provide the correct idle speed in proportion to the choke valve opening. When the choke valve reaches its fully open position, the cam rotates free of the fast idle screw and allows the throttle lever to return to the curb idle speed position when released.

If the engine is flooded during starting, the choke valve may be opened to vent excess fuel by depressing the accelerator pedal to the floor and rotating the engine with the starter motor. With the accelerator linkage in this position, a tang on the throttle lever contacts the fast idle cam and causes the choke rod to move upward to open the choke valve a predetermined distance.

IDLE SPEED CONTROL

The idle speed control Sole-Vac throttle positioner is part of the BBD carburetor assembly. It is activated in two ways, by an electric holding solenoid and by a pneumatic vacuum actuator. The holding solenoid is capable of maintaining a preset throttle position, but it does not have the capability of moving the throttle out to a new position. The vacuum actuator portion of the Sole-Vac throttle positioner, however, is capable of moving the throttle to a new position when manifold vacuum is applied to it. Once the throttle is positioned by the vacuum actuator, the holding solenoid maintains the position.

The Sole-Vac throttle positioner has three positions: Off, or deactivated, position (curb idle); holding solenoid position; and vacuum actuator position. Manifold vacuum is applied to the vacuum actuator through an electric vacuum switching solenoid that allows vacuum stored in a reservoir to engage it. The electric vacuum switching solenoid is controlled either by the idle speed controller (non-feedback) or by the CEC system microprocessor.

The holding solenoid is energized if either the intake manifold (EFE) heater, air conditioner or rear window defogger are in use; the vacuum actuator is engaged if the air cleaner air temperature is below approximately 60°F (16°C). When the air temperature is above 60°F (16°C), the vacuum actuator is engaged when the engine idle speed drops below calibrated minimum speed (AT: 435 ± rpm, MT: 462.5 ± 10 rpm). The vacuum actuator moves the throttle position (via the electric vacuum switching solenoid) until a calibrated maximum speed (AT: 1050 ± 100 rpm, MT: 1175 ± 150 rpm) has been reached, at which time it permits the throttle to close (i.e., to decrease speed), either to the holding solenoid

position (if the intake manifold heater, A/C or rear window defogger are in use) or to the normal curb idle speed position.

Refer to Feedback Systems within this chapter for additional information and diagnosis procedures.

CARBURETOR REPLACEMENT

Removal

- (1) Remove air cleaner. Plug vacuum hoses.
- (2) Identify all hoses attached to carburetor for aid during installation.
- (3) Remove throttle cable from throttle lever and disconnect vacuum hoses, return spring, PCV hose, fuel pipe fitting, choke heat wire connector, solenoid wire connector and stepper motor wire harness connector, if equipped.
- (4) Remove carburetor retaining nuts. Remove carburetor. Remove carburetor gasket from spacer.

Installation

- (1) Clean gasket mounting surface of spacer. Install replacement gasket on spacer. Position carburetor on spacer and gasket and install nuts. To prevent leakage, distortion or damage to carburetor body flange, alternately tighten nuts in crisscross pattern.
- (2) Connect fuel pipe fitting, throttle cable, choke heater wire connector, PCV hose, return spring, all vacuum hoses, solenoid wire connector and stepper motor wire harness connector, if equipped.

WARNING: Use extreme caution when engine is operating. Do not stand in direct line with fan. Do not put hands near pulleys, belts or fan. Do not wear loose clothing.

- (3) Adjust engine curb idle speed. Refer to Chapter 1A—General Service and Diagnosis.
- (4) Install air cleaner and vacuum hoses.

CARBURETOR OVERHAUL

The following procedure applies to a complete overhaul with the carburetor removed from the engine.

A complete disassembly is not necessary when performing routine service adjustments. In most instances, service adjustments of individual circuits can be accomplished without removing the carburetor from the engine. Refer to Service Adjustment Procedures.

A complete carburetor overhaul includes disassembly, thorough cleaning, inspection and replacement of all gaskets and worn or damaged parts. It also includes curb idle speed adjustment, mixture adjustment (if mixture adjustment screws have been removed) and fast idle adjustment after the carburetor is installed. Refer to figure 1J-99 for parts identification.

Stepper Motor

The stepper motor used with feedback carburetors has two tapered metering pins that interact with two air cavities located inside the main body of the carburetor.

The air intake for the feedback air input is located behind the main cluster inside the carburetor.

When the stepper motor "steps" to the rich "rail," each metering pin is moved the maximum distance into an air cavity.

When the stepper motors "steps" to the "lean" rail, each metering pin is pulled the maximum distance out of an air cavity.

Refer to Computerized Emission Control (CEC) System for additional information.

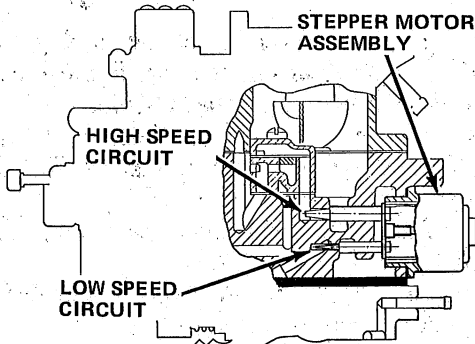

Metering Pins in Cavities (Rich)

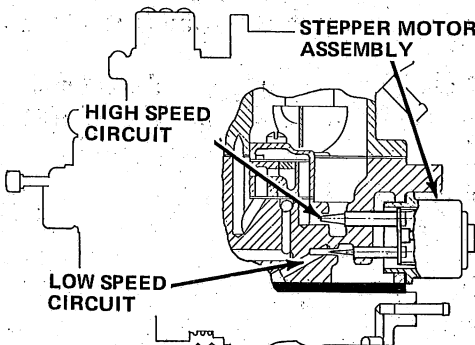

Metering Pins Out of Cavities (Lean)

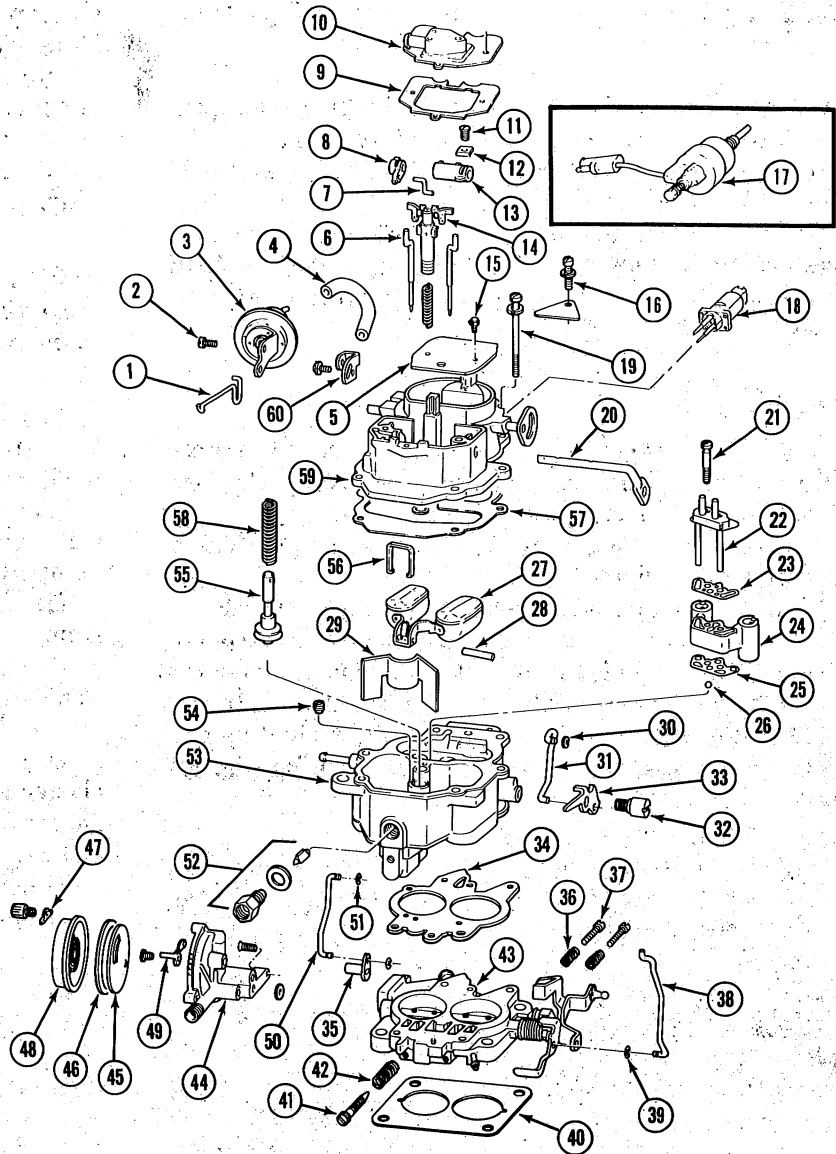

- 1. DIAPHRAGM CONNECTOR LINK
- 2. SCREW
- 3. CHOKE VACUUM DIAPHRAGM
- 4. HOSE
- 5. VALVE
- 6. METERING ROD
- 7. S-LINK
- 8. PUMP ARM
- 9. GASKET
- 10. ROLLOVER CHECK VALVE
- 11. SCREW
- 12. LOCK
- 13. ROD LIFTER
- 14. VACUUM PISTON
- 15. PISTON
- 16. AIR HORN RETAINING SCREW (SHORT)
- 17. SOLENOID
- 18. STEPPER MOTOR
- 19. AIR HORN RETAINING SCREW (LONG)
- 20. PUMP LEVER

- 21. VENTURI CLUSTER SCREW
- 22. IDLE FUEL PICK UP TUBE
- 23. GASKET
- 24. VENTURI CLUSTER
- 25. GASKET
- 26. CHECK BALL (SMALL)
- 27. FLOAT
- 28. FULCRUM PIN
- 29. BAFFLE
- 30. CLIP
- 31. CHOKE LINK
- 32. SCREW
- 33. FAST IDLE CAM
- 34. GASKET
- 35. THERMOSTATIC CHOKE SHAFT
- 36. SPRING
- 37. SCREW
- 38. PUMP LINK
- 39. CLIP
- 40. GASKET

- 41. MIXTURE SCREW
- 42. SPRING
- 43. THROTTLE BODY
- 44. CHOKE HOUSING
- 45. BAFFLE
- 46. GASKET
- 47. RETAINER
- 48. CHOKE COIL
- 49. LEVER
- 50. CHOKE ROD
- 51. CLIP
- 52. NEEDLE AND SEAT ASSEMBLY
- 53. MAIN BODY
- 54. MAIN METERING JET
- 55. ACCELERATOR PUMP PLUNGER
- 56. FULCRUM PIN RETAINER
- 57. GASKET
- 58. SPRING
- 59. AIR HORN
- 60. LEVER

Fig. 1J-99 Parts Identification—Carter Model BBD Carburetor

NOTE: When using an overhaul kit, use all parts included in the kit.

NOTE: Flooding, hesitation on acceleration, and other performance problems are in many instances caused by the presence of debris, water, or other foreign matter in the carburetor. To aid in diagnosing the problem, carefully remove the carburetor from the engine without removing the fuel from the bowl. Examine the bowl contents for contamination as the carburetor is disassembled.

Disassembly

- (1) Place carburetor on repair stand to protect throttle valves from damage and to provide stable work base. Remove stepper motor, if equipped.
- (2) Remove retaining clip from accelerator pump arm link and remove link (fig. 1J-100).
- (3) Remove cover and gasket from top of air horn.
- (4) Remove screws and locks from accelerator pump arm and vacuum piston rod lifter. Slide pump lever out of air horn. Remove pump arm and rod lifter. Lift vacuum piston and metering rod assembly straight up and out of air horn. Remove vacuum piston spring (fig. 1J-101).

phragm, linkage and bracket assembly. Place diaphragm aside to be cleaned separately.

(8) Remove fast idle cam retaining screw. Remove fast idle cam, choke link and clip.

(9) Grind off head of torque-head screws and remove choke cover assembly and housing from throttle body.

NOTE: When cover is removed from housing, remove remaining portion of screws from housing by twisting counterclockwise with locking pliers.

(10) Remove air horn retaining screws and lift air horn straight up away from main body. Remove solenoid, if equipped. Discard gasket (fig. 1J-102).

(11) Invert air horn and compress accelerator pump drive spring. Remove S-link from pump shaft. Remove pump assembly.

(12) Remove fuel inlet needle valve, seat and gasket from main body.

(13) Remove float fulcrum pin retainer and baffle. Remove floats and fulcrum pin (fig. 1J-103).

(14) Remove main metering jets (fig. 1J-104).

(15) Remove venturi cluster screws. Remove venturi cluster and gaskets from main body. Discard gaskets. Do not remove idle orifice tubes or main vent tubes from cluster.

(16) Invert carburetor main body and drop out accelerator pump discharge check valve ball (fig. 1J-105).

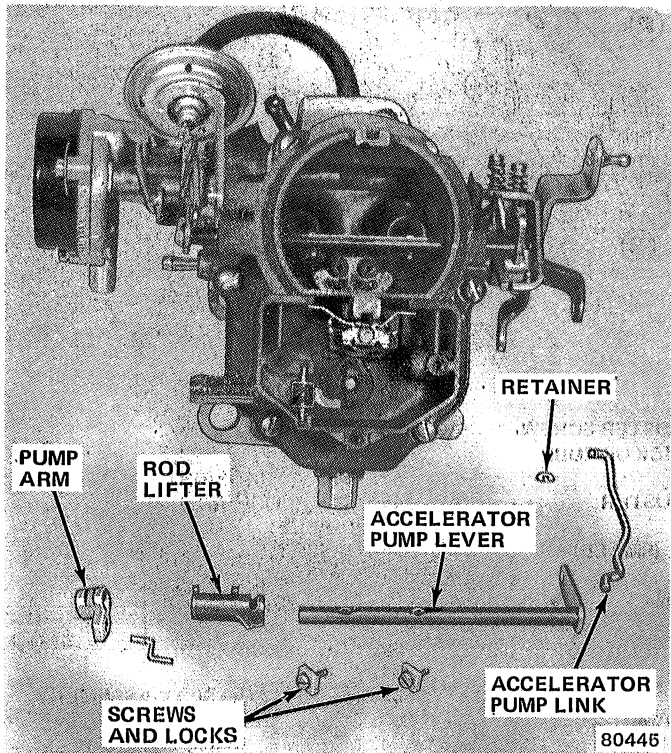

Fig. 1J-100 Accelerator Pump and Lever

- (5) Disconnect clips and remove choke rod from choke housing lever and choke lever.
- (6) Remove screw and lever from choke shaft.
- (7) Remove vacuum hose from carburetor main body and choke vacuum diaphragm. Remove choke dia-

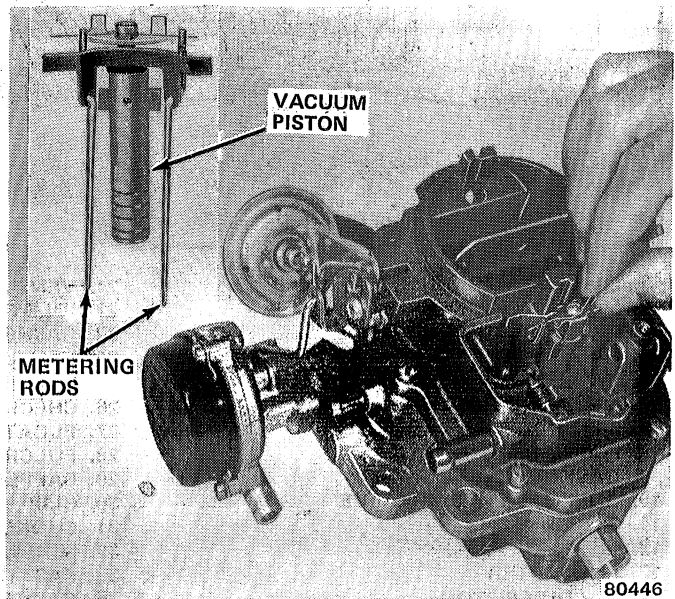

Fig. 1J-101 Removing Piston and Metering Rods

The cleaning and inspection procedure listed below does not include those parts contained in the carburetor overhaul repair kit. Install all gaskets and parts included in the repair kit when the carburetor is assembled. Discard original gaskets and replaced parts.

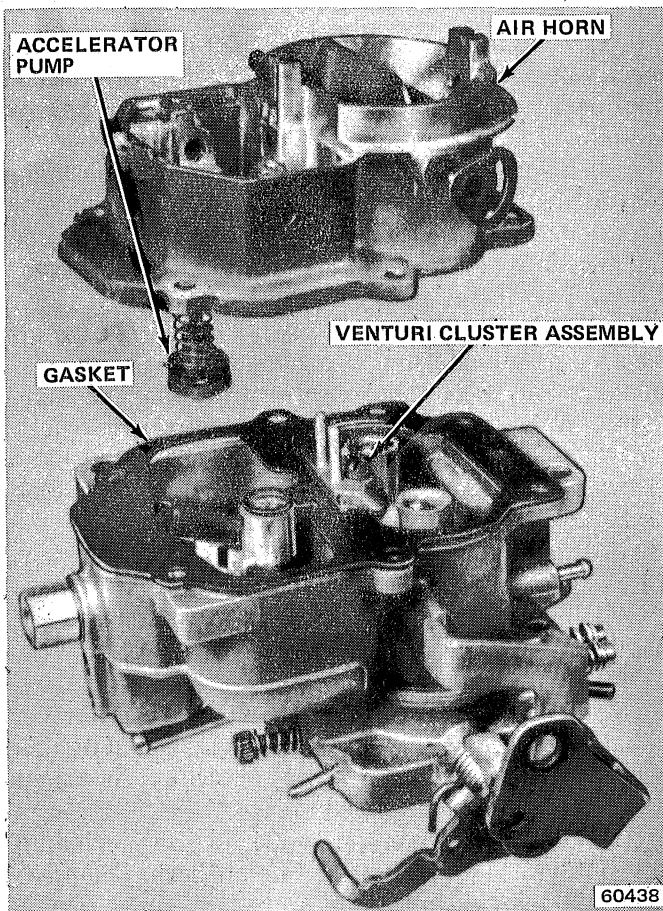

Fig. 1J-102 Removing Air Horn

CAUTION: Do not use a wire brush to clean any part. Do not use a drill or wire to clean openings or passages. This may enlarge the passages and alter the calibration of the carburetor.

NOTE: If it is necessary to remove idle mixture adjustment screws because air pressure or soaking did not sufficiently clean the air passages, remove dowel pins with drill and punch.

(17) Remove screws attaching throttle body to main body and separate bodies. Discard gasket.

(18) Count number of turns required to lightly seat each mixture adjustment screw and record for assembly reference. Remove idle mixture screws and springs from throttle body.

Cleaning and Inspection

Debris, gum, water, or carbon contamination in the carburetor or on exterior moving parts is often responsible for unsatisfactory engine performance. Efficient carburetion depends upon careful cleaning and inspection.

Wash all parts, except vacuum diaphragm, in clean commercial carburetor cleaning solvent. If a commercial

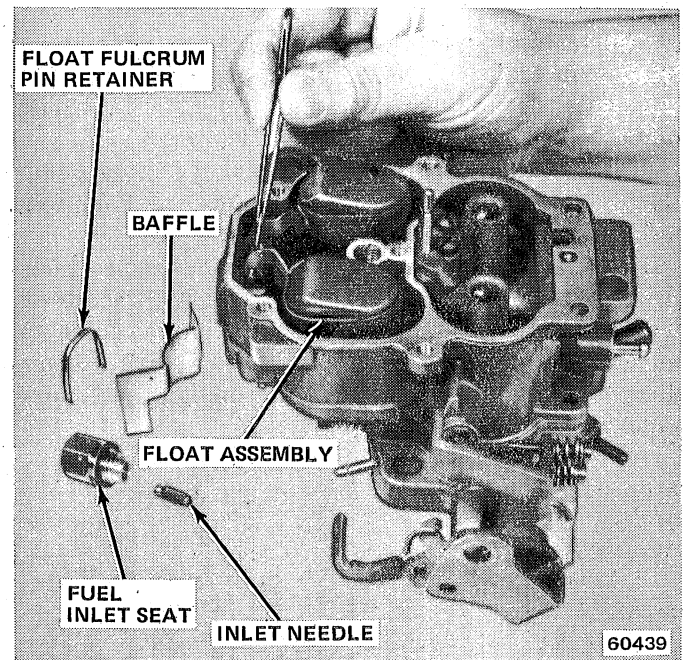

Fig. 1J-103 Float Assembly

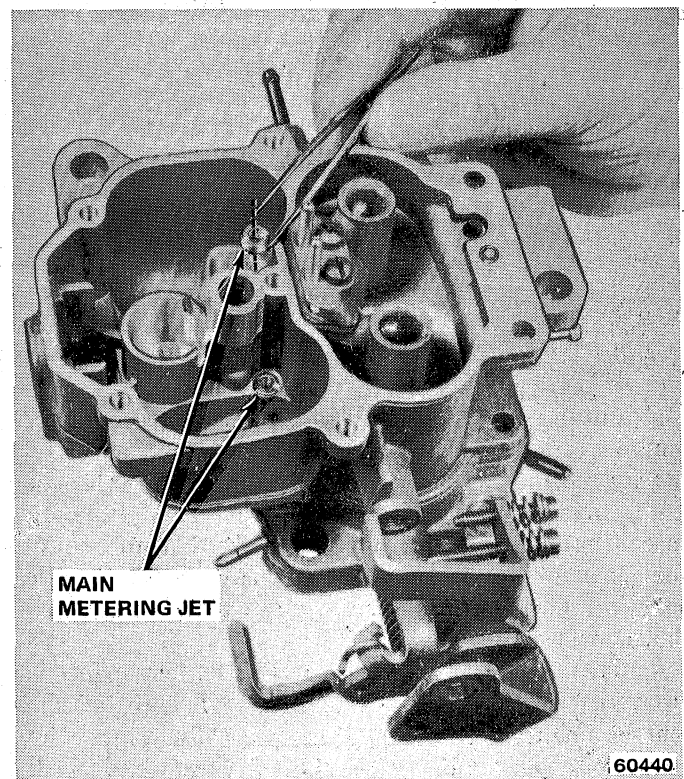

Fig. 1J-104 Main Metering Jets

solvent is not available, use mineral spirits, lacquer thinner or denatured alcohol.

(5) Clean passages and ball seat if leakage is evident. If leakage persists, replace main body.

(6) Install replacement gaskets on venturi-cluster, install cluster screws and tighten securely.

(7) Install main metering jets.

(8) Install float assembly with fulcrum pin and pin retainer in main body. Install needle, seat and gasket and tighten securely. Adjust float level. Refer to Service Adjustment Procedures. Install baffle plate.

(9) Place accelerator pump drive spring on pump plunger shaft and insert shaft into air horn. Compress spring and insert S-link.

If commercial solvent is used, rinse the cleaned parts in hot water to remove all traces of solvent, then blow dry with compressed air. Wipe the parts that cannot be immersed in solvent with a clean, soft, dry cloth. Ensure all residue, gum, carbon and other foreign matter are removed from all parts.

Force compressed air through all passages of the carburetor.

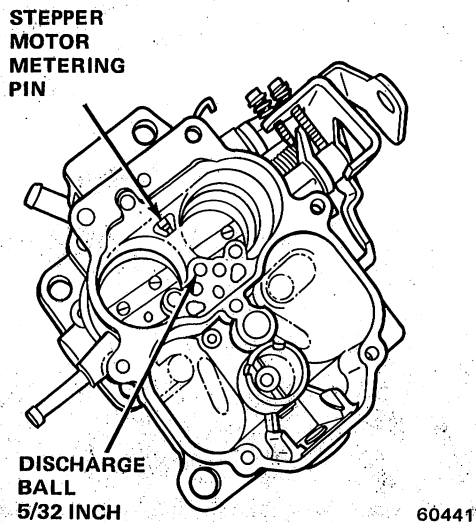

Fig. 1J-105 Check Valve Ball Location

Examine the choke shaft for excessive looseness or binding condition. Inspect the choke valve for nicked edges and for ease of operation. Inspect the throttle shaft for excessive looseness or binding in its bore. Inspect throttle valves for burrs or nicks that might prevent proper closing. Inspect the main body, throttle body, air horn, venturi assemblies, choke housing and choke cover for cracks.

Replace the float if the arm needle contact surface is grooved. If the float is serviceable, polish the needle contact surface of the arm with crocus cloth or an equivalent material. Replace float shaft if worn. Replace all damaged screws and nuts and all distorted or broken springs. Inspect all gasket mating surfaces for nicks or burrs. Replace any parts that have damaged gasket surfaces.

Assembly

NOTE: Ensure all holes in the replacement gaskets have been correctly punched and that no foreign material has adhered to the gaskets.

(1) If removed, install idle mixture screws and springs in body. Turn screws lightly against their seats, then back off number of turns recorded during disassembly. Install dowel pins in throttle body.

(2) Invert main body, place throttle body on main body, and align. Install screws and tighten securely.

(3) Install accelerator pump discharge check valve ball 5/32-inch (3.96 mm) diameter in discharge passage.

(4) Test operation of accelerator pump. Pour clean no-lead fuel into carburetor bowl 1/2 inch (12.7 mm) deep. Insert pump piston into pump cylinder, move piston up and down gently to expel air from pump passage. With suitable clean brass rod, hold discharge check valve ball firmly against its seat. Raise piston and press down. No fuel should be emitted from either intake or discharge passages (fig. 1J-106).

(5) Clean passage and ball seat if leakage is evident. If leakage persists, replace main body.

(6) Install replacement gaskets on venturi cluster, install cluster screws and tighten securely.

(7) Install main metering jets.

(8) Install floats with fulcrum pin and pin retainer in main body. Install needle, seat and gasket and tighten securely. Adjust float level. Refer to Service Adjustment Procedures. Install baffle plate.

(9) Place accelerator pump drive spring on pump plunger shaft and insert shaft into air horn. Compress spring and insert S-link.

(10) Place vacuum piston spring in vacuum piston bore. Position replacement gasket on main body and install air horn. Install solenoid. Tighten retaining screws alternately one turn at a time to compress gasket evenly.

(11) Measure vacuum piston gap. Refer to Service Adjustment Procedures and figure 1J-107. Carefully install step-up piston and metering rod assembly into its bore in air horn. Ensure metering rods are in main metering jets. Ensure metering rod springs are installed properly (fig. 1J-107).

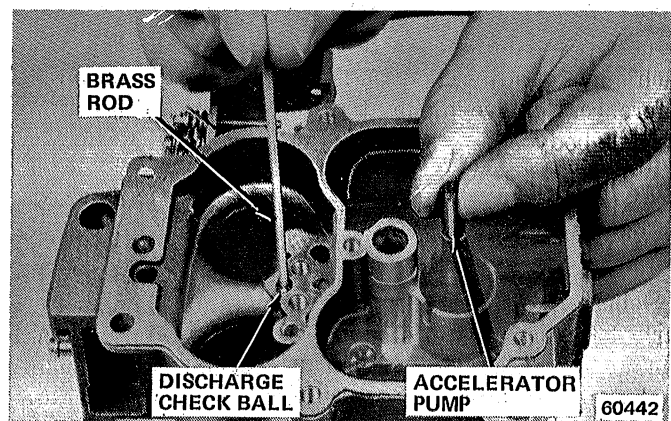

Fig. 1J-106 Accelerator Pump Test

(12) Position two lifting tangs of plastic rod lifter under piston yoke. Slide shaft of accelerator pump lever through rod lifter and pump arm. Install locks and adjusting screws, but do not tighten.

(13) Install fast idle cam and linkage. Tighten retaining screw securely.

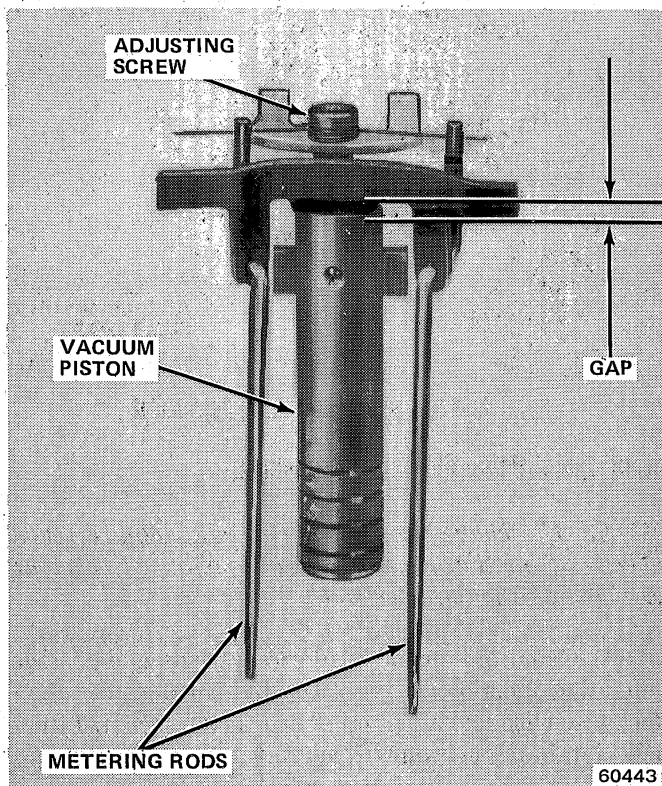

Fig. 1J-107 Vacuum Piston and Metering Rod Assembly

(14) Connect accelerator pump linkage to pump lever and throttle lever. Install retaining clip.

(15) Adjust vacuum piston and accelerator pump. Refer to Service Adjustment Procedures.

(16) Install dust cover, using replacement gasket.

(17) Install diaphragm assembly and secure with attaching screws. Do not connect vacuum hose to diaphragm fitting until initial choke valve clearance has been adjusted. Refer to Service Adjustment Procedures.

(18) Engage diaphragm link with slot in choke lever. Install choke lever and screw on choke shaft.

(19) Install choke housing on throttle body.

(20) Install baffle, gasket and cover on housing. Turn cover 1/4 turn rich (clockwise) and retain in position with one straight-slot screw.

(21) Install link and retainer between choke lever and choke housing lever.

(22) Connect link and retainer to fast idle cam and choke lever.

(23) Adjust initial choke valve clearance. Refer to Service Adjustment Procedures.

(24) Adjust fast idle cam clearance. Refer to Service Adjustment Procedures.

(25) Adjust choke unloader clearance. Refer to Service Adjustment Procedures.

(26) Remove straight-slot screw that is retaining choke cover and adjust cover index to specified notch (refer to Specifications).

(27) Install replacement torque-head (break off) screws to retain cover.

NOTE: Heads of screws will break off when tightened beyond the calibrated torque.

(28) Install stepper motor (if equipped) with replacement gasket.

SERVICE ADJUSTMENT PROCEDURES

Float Level Adjustment

(1) Remove air horn.

(2) Raise float gently against needle and hold (fig. 1J-108).

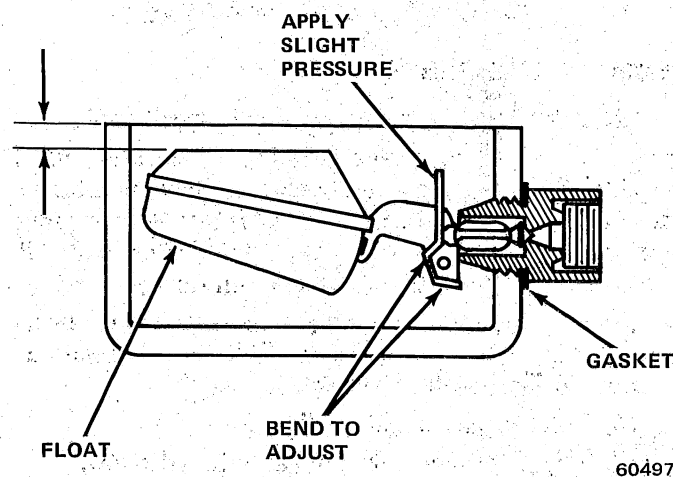

Fig. 1J-108 Float Level Adjustment

(3) Place straightedge across float bowl to measure float level. Refer to Specifications.

CAUTION: Never bend float lever while it is resting against needle. Pressure may damage synthetic tip and cause a misadjustment.

(4) If adjustment is necessary, release float and bend float lever.

(5) Install air horn.

Vacuum Piston Gap Adjustment

The vacuum piston gap is a critical adjustment (fig. 1J-109). Turning the adjusting screw clockwise richens the air/fuel mixture. Turning the adjusting screw counterclockwise leans the air/fuel mixture. Turn adjusting screw to adjust gap. Refer to Specifications.

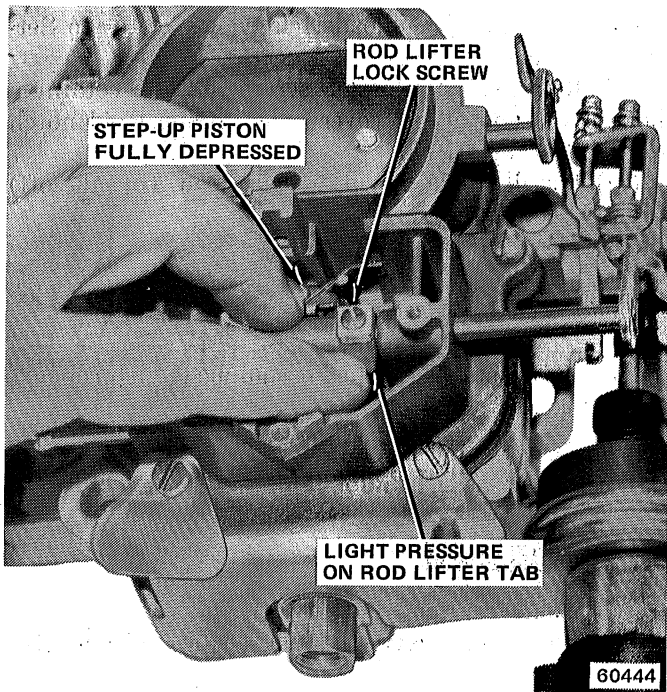

Fig. 1J-109 Vacuum Piston Adjustment

Vacuum Piston Adjustment

- (1) Adjust gap in vacuum piston to specification.
- (2) Back off idle speed adjustment screw until throttle valves are completely closed. Count number of turns and note so that screw can be returned to original position. Turn idle speed adjustment screw until it barely contacts stop, then turn one full turn further.
- (3) Fully depress vacuum piston while holding moderate pressure on rod lifter tab. While in this position, tighten rod lifter lock screw (fig. 1J-109).
- (4) Release piston and rod lifter.
- (5) Adjust accelerator pump as outlined below.
- (6) Return idle speed adjustment screw to its original position.
- (7) Install dust cover.

Accelerator Pump Adjustment

- (1) Remove dust cover.
- (2) Back off idle speed adjustment screw to completely close throttle valves. Open choke valve so that fast idle cam allows throttle valves to seat in bores.
- (3) Turn idle speed adjustment screw in until it barely contacts stop. Then continue two complete turns.
- (4) Measure distance between surface of air horn and top of accelerator pump shaft (fig. 1J-110). Refer to Specifications for correct dimension.
- (5) Loosen pump arm adjustment lock screw and rotate sleeve to adjust pump travel to correct distance. Tighten lock screw.
- (6) Install cover and screws.

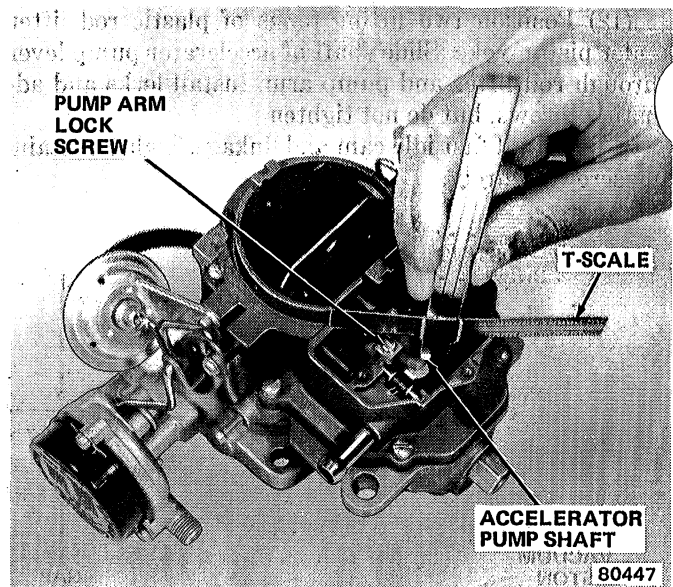

Fig. 1J-110 Accelerator Pump Adjustment

Initial Choke Valve Clearance Adjustment

NOTE: The choke should not normally require readjustment from the original factory assembly adjustment except after a major overhaul.

- (1) Grind off torque-head screw heads and remove remaining portions of screws by turning counter-clockwise with locking pliers. Turn choke cover 1/4 turn rich. Retain in position with one straight-slot screw.
- (2) Open throttle valve slightly to place fast idle screw on high step of cam.
- (3) Use Tool J-23738 or any vacuum source that holds at least 19 inches of mercury (19 in. Hg/64 kPa) to pull in diaphragm against stop.
- (4) Measure clearance between choke plate and air horn wall. Refer to Specifications.
- (5) Adjust clearance by bending diaphragm connector link (fig. 1J-111).
- (6) Remove straight-slot screw and adjust cover index to specified notch. Install replacement torque-head (break off) screws.

NOTE: Head of screws will break off when tightened beyond the calibrated torque.

Fast Idle Cam Position Adjustment

- (1) Remove torque-head screws and position choke cover 1/4 turn rich. Retain with one straight-slot screw.
- (2) Open throttle slightly and place fast idle screw on second step of cam.
- (3) Measure distance between choke plate and air horn wall (fig. 1J-112). Refer to Specifications for correct dimension.

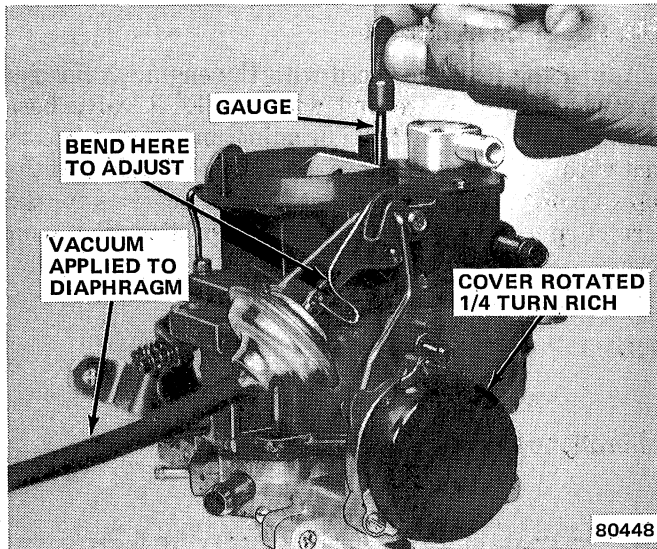

Fig. 1J-111 Initial Choke Valve Clearance

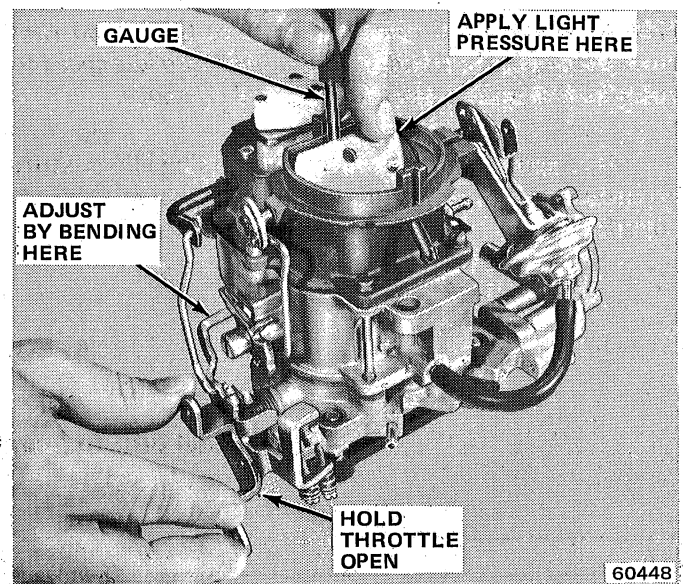

Fig. 1J-113 Choke Unloader Adjustment

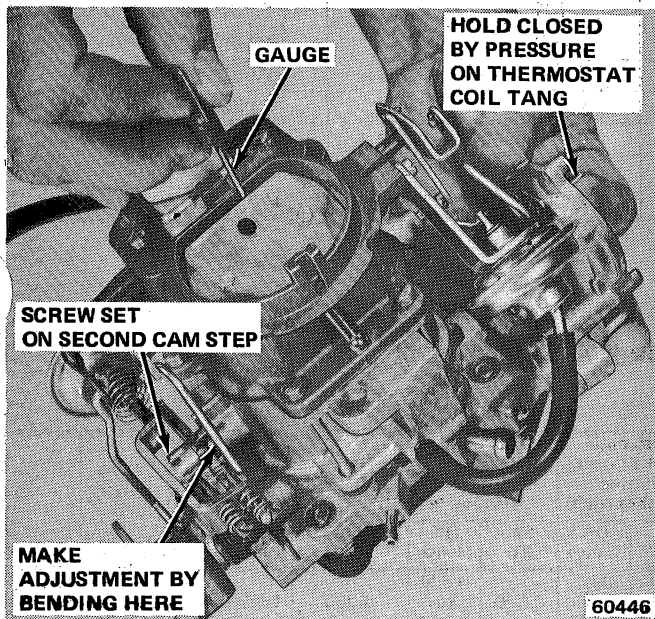

Fig. 1J-112 Fast Idle Cam Adjustment

(4) Adjust by bending fast idle cam link down to increase distance or up to decrease distance.

(5) Remove choke cover screw and adjust index to specified notch. Install replacement torque-head screws.

Choke Unloader Adjustment

(1) Hold throttle wide open (fig. 1J-113).

(2) Apply light pressure to choke plate and hold in closed position.

(3) Measure distance between choke plate and air horn wall. Refer to Specifications.

(4) Adjust by bending unloader tang. Do not bend tang so that it binds or interferes with any other part.

Automatic Choke Adjustment (On or Off Vehicle)

The automatic choke adjustment is made by loosening the housing cover retaining screws and rotating cover in the required direction. Rich and lean are indicated by the arrow on the face of the cover. Refer to Specifications for the correct position. The specified position will be satisfactory for most driving conditions.

Idle Speed and Mixture Adjustment

Refer to idle speed adjustment procedure outlined in Chapter 1A—General Service and Diagnosis.

Idle Mixture Adjustment

(1) Install carburetor, fuel pipe, vacuum hoses, etc.

(2) Connect tachometer, start engine and warm to operating temperature.

(3) Position gear selector: manual—Neutral, automatic—Drive. Set parking brake firmly.

(4) Adjust idle speed.

(5) Adjust mixture screw(s) leaner (clockwise) until perceptible loss of rpm is noted.

(6) Turn mixture screw(s) richer (counterclockwise) until highest rpm indication is obtained. Do not turn screw(s) any further than point at which highest rpm is first obtained. This is referred to as lean best idle.

NOTE: Engine speed will increase above curb idle speed an amount that corresponds approximately to the lean drop specification to be obtained in step (7).

(7) As final adjustment, turn mixture screws clockwise (leaner) to obtain 50 rpm drop in engine speed. Turn both idle mixture screws in small, equal amounts until specified drop is achieved.

NOTE: If the final rpm differs more than ± 30 rpm from the original curb idle rpm, adjust curb idle speed to specification and repeat steps (6) and (7) above.

(8) Install dowel pins after performing idle mixture adjustment. Use care to prevent disturbing mixture adjustments.

Fast Idle Speed Adjustment

Adjust the fast idle speed with the engine at normal operating temperature and with the EGR valve hose disconnected. Position fast idle adjustment screw in contact with the second step and against the shoulder of the top step of fast idle cam. Refer to Specifications for the correct rpm. Adjust by turning the fast idle adjustment screw.

SPECIFICATIONS

Model BBD Carburetor Calibrations (Inches)

	8338	8339	8340	8341	8349	8351
Throttle Bore Size	1.44	1.44	1.44	1.44	1.44	1.44
Main Venturi Size	1.0625	1.0625	1.0625	1.0625	1.0625	1.19
Fuel Inlet Diameter	0.101	0.101	0.101	0.101	0.101	0.101
Low Speed Jet (Tube)	0.0295	0.0295	0.0295	0.0295	0.0295	0.0295
Economizer	0.057	0.057	0.057	0.055	0.059	0.057
Idle Air Bleed	0.067	0.067	0.067	0.067	0.063	0.063
Main Jet Size	0.092	0.092	0.092	0.092	0.086	0.089
Accelerator Pump Jet	0.033	0.033	0.033	0.033	0.033	0.033
Main Metering Jet Number	120-392	120-392	120-392	120-392	120-386	120-389

80608

Model BBD Carburetor Service Specifications

List Number	Application	Float Level (Inches)		Vacuum Piston Gap (Inches)		Initial Choke Valve Clearance (Inches)		Fast Idle Cam Setting (Inches)		Automatic Choke Cover Setting (Notches Rich)		Accelerator Pump Dimensions (Inches)		Choke Unloader (Inches)	Fast Idle Speed [Ⓞ]		Choke Bimetal ID	Choke
		Set To	OK Range	Set To	OK Range	Set To	OK Range	Set To	OK Range	Set To	OK Range	Set To	OK Range		Set To	OK Range		
8338	258 (Auto) CJ Cal. Alt	0.25	0.218 to 0.282	0.035	0.020 to 0.050	0.140	0.125 to 0.155	0.095	0.030 to 0.110	1 NR	1/2 to 1-1/2	0.520	0.500 to 0.540	0.280	1850	1750 to 1950	ET	TR
8339	258 (Man.) CJ California	0.25	0.218 to 0.282	0.035	0.020 to 0.050	0.140	0.125 to 0.155	0.095	0.080 to 0.110	1 NR	1/2 to 1-1/2	0.520	0.500 to 0.540	0.280	1700	1600 to 1800	ET	
8340	258 (Auto) Cke,Wag,Trk 50S	0.25	0.218 to 0.282	0.035	0.020 to 0.050	0.150	0.135 to 0.165	0.110	0.070 to 0.100	1 NR	1/2 to 1-1/2	0.520	0.500 to 0.540	0.280	1700	1600 to 1800	ET	
8341	258 (Man.) Cke,Wag,J-10 50S	0.25	0.218 to 0.282	0.035	0.020 to 0.050	0.150	0.135 to 0.165	0.150	0.080 to 0.110	1 NR	1/2 to 1-1/2	0.520	0.500 to 0.540	0.280	1700	1600 to 1800	ET	
8349	258 (Man.) CJ 49 State	0.25	0.218 to 0.282	0.035	0.020 to 0.050	0.128	0.113 to 0.143	0.095	0.080 to 0.110	2 NR	1-1/2 to 2-1/2	0.500	0.480 to 0.520	0.280	1700M 1850A	1600/1800/1750/1950	ET (B1)	
8351	258 (Man.) CJ Altitude	0.25	0.218 to 0.282	0.035	0.020 to 0.050	0.130	0.115 to 0.145	0.095	0.080 to 0.110	0 NR	-1/2 to +1-1/2	0.520	0.500 to 0.540	0.280	1700	1600 to 1800	ER 3	

[Ⓞ]Hot with EGR valve hose disconnected.

TR — Tamper Resistant

CARBURETOR MODEL 2150-2 VENTURI

	Page		Page
Altitude Compensated Model 2150 Carburetor	1J-71	Choke Mechanism Service	1J-71
Carburetor Circuits	1J-59	General	1J-58
Carburetor Overhaul	1J-62	Service Adjustment Procedures	1J-67
Carburetor Replacement	1J-62	Specifications	1J-72

GENERAL

The Motorcraft Model 2150 carburetor (with altitude compensation) is a two-venturi carburetor that incorporates two lightweight aluminum assemblies, the air horn and the main body.

The air horn assembly serves as the main body cover and also contains the choke assembly and fuel bowl vents.

The throttle shaft assembly and all components of the fuel metering circuits are contained in the main body assembly. The automatic choke assembly and the solenoid are attached to the main body (fig. 1J-114).

The Model 2150 carburetor with altitude compensation uses an additional choke valve to aid cold weather engine start up.

This carburetor features a compensation circuit that mixes a metered amount of additional air into the air/fuel mixture to prevent an over-rich condition at higher altitudes. An automatic device (aneroid) reacts to atmospheric pressure and overrides the compensation feature at lower altitudes.

NOTE: With extremely low barometric pressure conditions, the aneroid may open the vent valve at sea level. This is normal and does not indicate a faulty component.

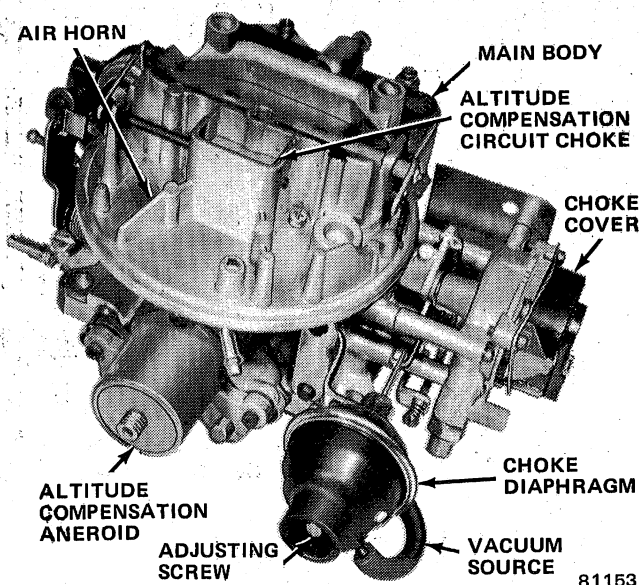

Fig. 1J-114 Model 2150 Carburetor Assembly

Identification

Each carburetor is identified by a code number and build date that is stamped on an identification tag. Each carburetor build month is coded alphabetically beginning with the letter A for January and ending with the letter M for December (the letter I is not used). The tag is attached to the carburetor and must remain with it to assure proper identification (fig. 1J-115).

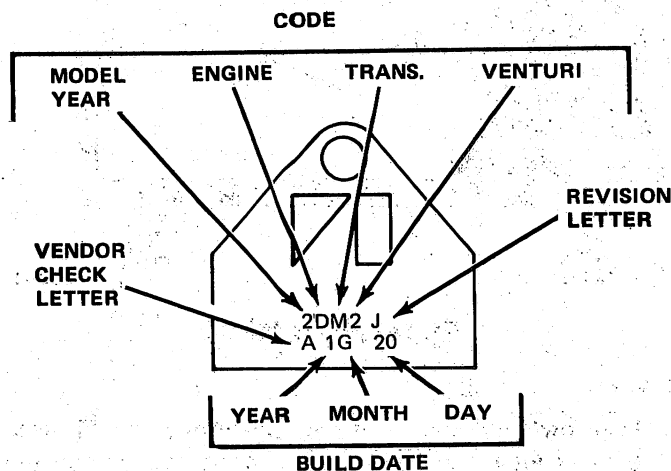

Fig. 1J-115 Identification Tag

CARBURETOR CIRCUITS

The Model 2150 carburetor utilizes six circuits: Float (Fuel Inlet), Idle Metering (Low Speed), Main Metering (High Speed), Pump, Choke and Altitude Compensation.

Float (Fuel Inlet) Circuit

Pressurized fuel enters the fuel bowl through the fuel inlet fitting in the main body. The Viton-tipped fuel inlet needle is controlled by the float and lever assembly, which is hinged on the float shaft. A wire retainer is hooked over grooves on opposite ends of the float shaft and into a groove behind the fuel inlet needle seat. The retainer holds the float shaft firmly in the fuel bowl guides and also centers the float assembly in the fuel bowl. An integral retaining clip is hooked over the end of the float lever and attached to the fuel inlet needle. This assures reaction of the fuel inlet needle during downward movement of the float (fig. 1J-116).

The float circuit maintains the correct fuel level in the bowl. This enables the fuel metering circuits to deliver the proper air/fuel mixture to the combustion chambers. The amount of fuel entering the bowl is regulated by the distance the fuel inlet needle is raised off its seat. The float drops as the fuel level drops and allows the fuel inlet needle to move off its seat. This permits additional fuel to enter the bowl. When the fuel reaches the preset level, the fuel inlet needle is lowered and admits only enough fuel to replace that being used.

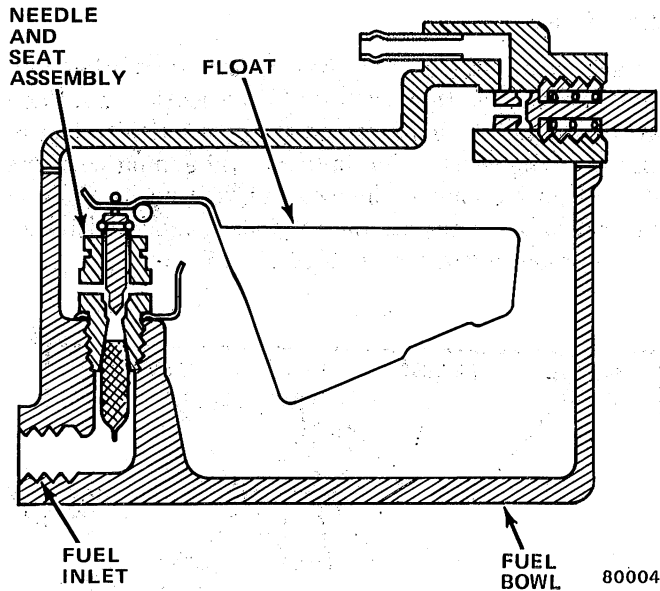

Fig. 1J-116 Float Circuit

Bowl Vent

Two bowl vents are required. The internal vent is used to balance air pressure in the fuel bowl when the engine is operating. The external vent provides a method of controlling fuel vapor in the bowl when the engine is not operating.

The external fuel bowl vent permits vapor to move from the carburetor to the fuel vapor storage canister. A bell crank attached to the accelerator pump housing actuates the bowl vent (fig. 1J-117). At idle or solenoid Off position (if equipped), the vent opens, permitting vapor to pass. At any throttle position above idle, the vent is mechanically closed.

Idle Metering (Low Speed) Circuit

Fuel for idle and low speed operation flows from the fuel bowl through the main jets into the main wells. From the main wells, the fuel is metered as it passes through calibrated restrictions at the lower end of the idle tubes. After flowing through the idle tubes, the fuel enters diagonal passages above the tubes. The fuel is metered again as it flows downward through restrictions at the lower end of the diagonal passages and then enters the idle passages in the main body (fig. 1J-118).

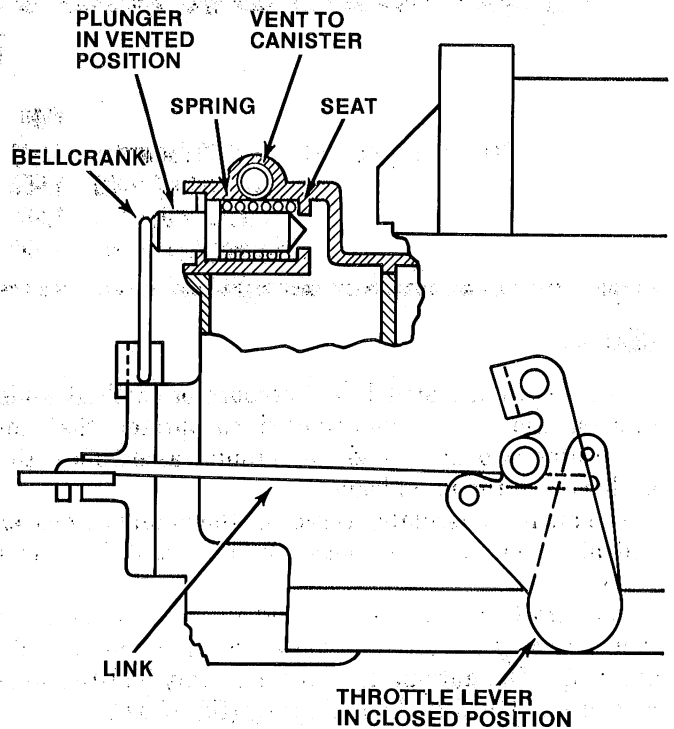

Fig. 1J-117 External Bowl Vent

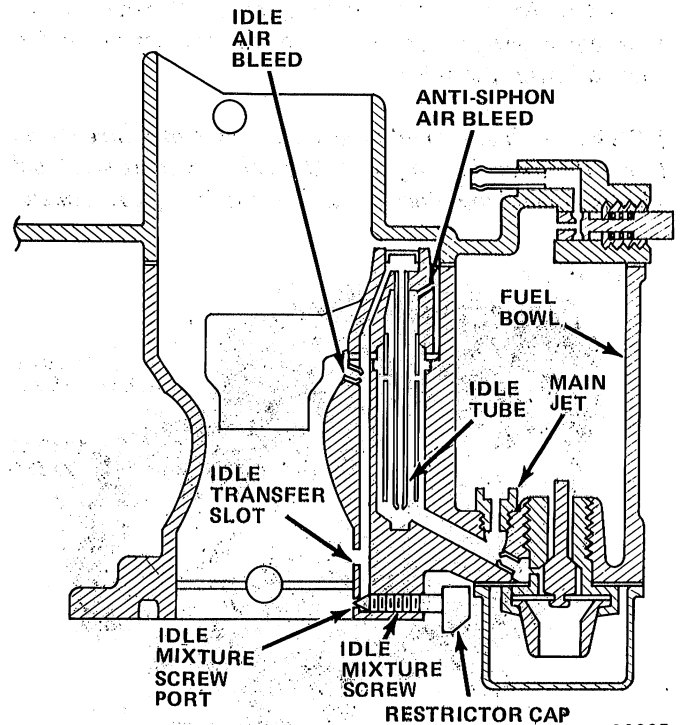

Fig. 1J-118 Idle Metering Circuit

Air enters the idle circuit through air inlets that are located in the main body directly below the booster

venturi. The air inlets serve as anti-siphon vents during off-idle, high speed operation and when the engine is stopped.

The air/fuel mixture moves down the idle passages past the idle transfer slots, which serve as additional air inlets during curb idle operation. The air/fuel mixture then moves past the idle mixture adjustment screw tips, which control the amount of discharge. From the adjustment screw ports, the air/fuel mixture moves through short horizontal passages and is discharged below the throttle valves.

At speeds slightly above idle, the idle transfer slots begin discharging the air/fuel mixture as the throttle valves expose them to manifold vacuum. As the throttle valves continue opening and engine speed increases, the airflow through the carburetor increases proportionately. This increased airflow creates a vacuum in the venturi and the main metering circuit begins discharging the air/fuel mixture. The discharge from the idle circuit tapers off as the main metering circuit begins discharging.

Main Metering (High Speed) Circuit

As engine speed increases, the air velocity through the booster venturi creates a low pressure area. Fuel flow through the main metering circuit is caused by atmospheric pressure in the fuel bowl and a lower pressure at the main discharge ports. Fuel flows from the fuel bowl, through the main jets and into the main wells. The fuel then moves up the main well tubes where it is mixed with air. The air, supplied through the main air inlets, mixes with the fuel through small holes in the sides of the main well tubes. The main air inlets meter an increasing amount of air, whenever venturi vacuum increases, to maintain the proper air/fuel mixture ratio. The mixture of fuel and air, being lighter than raw fuel, responds quickly to changes in venturi vacuum. It also atomizes more readily than raw fuel.

The air/fuel mixture moves from the main well tubes to the discharge ports and is discharged into the booster venturi (fig. 1J-119).

Anti-siphon air vents, located near the top of the main well tubes, prevent siphoning of fuel from the main well when decelerating.

Power Enrichment

During heavy load conditions or high speed operation, the air/fuel mixture ratio must be increased to provide higher engine power output. The power enrichment valve supplies extra fuel during this period. It is controlled by intake manifold vacuum (fig. 1J-120).

Manifold vacuum is applied to the power valve diaphragm from an opening in the base of the main body, through a passage in the main body and power valve

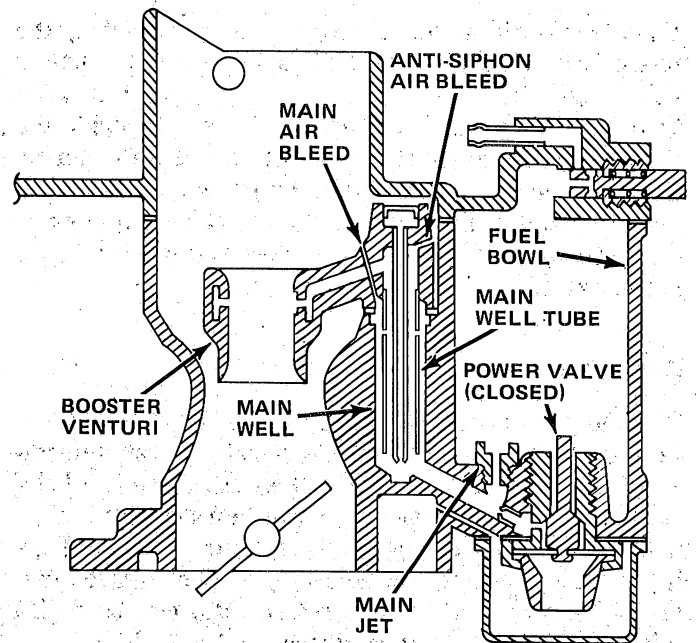

80006

Fig. 1J-119 Main Metering Circuit

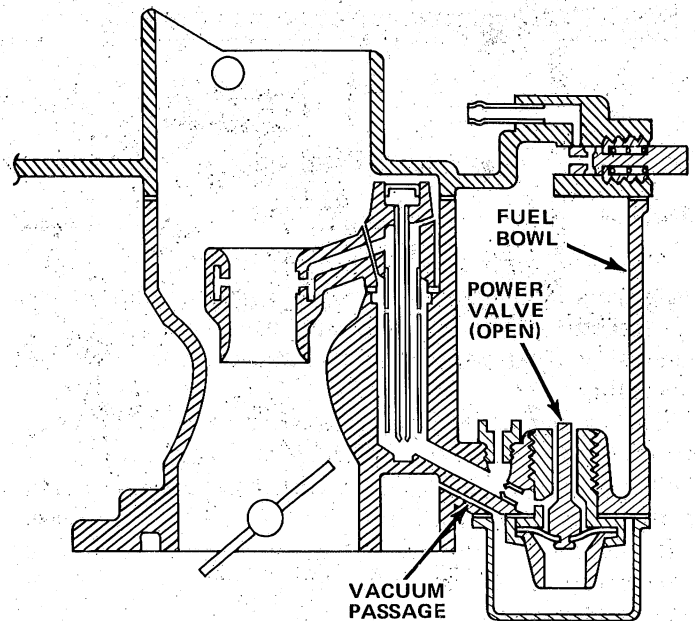

80008

Fig. 1J-120 Power Enrichment Valve

chamber to the power valve diaphragm. During engine idle and cruise speed conditions, manifold vacuum is high enough to overcome the power valve spring tension and holds the valve closed. When higher engine power output is required, the increased load on the engine results in decreased manifold vacuum. The power valve spring opens the first stage of the power valve when manifold vacuum drops below a predetermined value and a small amount of fuel flows through the valve.

When manifold vacuum drops to a lower value, the power valve spring opens the second stage of the power valve and allows a greater amount of fuel to flow through the valve. The fuel that flows through the power valve is added to the fuel in the main metering circuit to enrich the mixture. As engine load requirements decrease, manifold vacuum increases and overcomes the tension of the power valve spring, closing the power valve.

Pump Circuit

When the throttle valves are opened quickly, the airflow through the carburetor responds almost immediately. Because fuel is heavier than air, there is a brief lag in time before the fuel flow can gain sufficient velocity to maintain the proper air/fuel mixture ratio. During this lag, the pump circuit supplies the required fuel until the proper air/fuel mixture ratio can be maintained by the other metering circuits (fig. 1J-121).

The pump is charged when the throttle valves are closed. The diaphragm return spring exerts force against the diaphragm and pushes it against the cover.

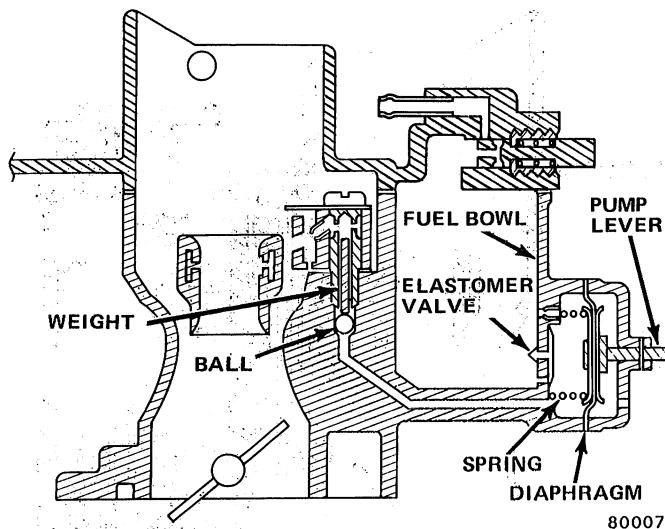

Fig. 1J-121 Pump Circuit

Fuel is drawn through the inlet, past the elastomer valve, and into the pump chamber. A discharge check ball and weight prevents air from being drawn into the pump chamber.

When the throttle valves are opened, the diaphragm rod is pushed inward forcing fuel from the pump chamber into the discharge passages. The elastomer valve seals the inlet hole during pump discharge preventing fuel from returning to the fuel bowl. Fuel under pressure unseats the discharge check ball and weight and is forced through the pump discharge screw. The fuel is then sprayed into the main venturi through discharge ports.

A vent is provided in the pump chamber to prevent vapor accumulation and pressure buildup.

Choke Circuit

The choke valve, located in the air horn assembly, provides a high vacuum above as well as below the throttle valves when closed. During cranking, vacuum above the throttle valves causes fuel to flow from the main and idle metering circuits. This provides the richer air/fuel mixture required for cold engine starting.

The choke shaft is connected by linkage to a bimetallic coil that winds up (contracts) when cold and unwinds (expands) when warm.

The position of the choke valve is controlled by the action of a vacuum modulator that exerts force against the tension of the bimetallic coil.

The altitude compensation circuit has a separate non-adjustable choke valve that is linked directly with the primary choke valve.

When the engine is cold, tension of the bimetallic coil holds the choke valve closed. When the engine is started, manifold vacuum is channeled through an opening at the base of the carburetor through a passage on the bottom side of the modulator diaphragm assembly, to move the diaphragm downward against the setscrew. At the same time, the modulator arm contacts a tang on the choke shaft. The downward movement of the diaphragm assembly compresses the piston spring and exerts a pulling force on the modulator arm, causing the choke valve to open slightly. This opening is referred to as initial choke valve clearance.

The bimetallic coil is warmed by electric heater element and, as the engine begins to warm up, heated air routed from the exhaust crossover through a heat tube to the choke housing. A thermostatically controlled bypass valve, which is an integral part of the choke heat tube, helps prevent premature choke valve opening during the early part of the engine warmup period. The valve regulates the temperature of the hot airflow to the choke housing by allowing outside unheated air to enter the heat tube. A thermostatic disc is incorporated in the valve. It is calibrated to close the valve at 75°F (24°C) and open it at 55°F (13°C).

The electric heater element and heated air entering the choke housing cause the bimetallic coil to begin unwinding and decrease the closing tension exerted against the choke valve. The coil gradually loses its tension and allows the choke valve to open.

When the engine reaches normal operating temperature, the bimetallic coil continues unwinding and exerts pressure against the choke linkage, forcing the choke valve fully open. A continual flow of heated air passes through the choke housing and is exhausted into the intake manifold. The bimetallic coil remains heated and the choke valve remains fully open until the engine is stopped and allowed to cool.

Air flowing through the choke housing must be filtered to minimize contamination of the choke coil and associated parts. The filtered air is supplied through a tube that originates inside the air cleaner.

A fast speed idle is required to prevent engine stalling during the warmup period. The fast idle cam, actuated by the choke rod, contacts the fast idle speed adjustment screw and increases engine speed in proportion to the choke valve opening. When the choke valve reaches the fully open position, the fast idle cam rotates free of the fast idle speed adjustment screw and allows the throttle lever to return to the curb idle speed position.

If the engine is accelerated during the warmup period, the resulting drop in manifold vacuum allows the bimetallic coil to momentarily close the choke valve. This provides a richer air/fuel mixture to prevent engine stalling.

If the engine is "flooded" during the starting operation, the choke valve may be opened manually to purge excess fuel from the intake manifold. This is accomplished by depressing the accelerator pedal to the floor and rotating the engine with the starter motor. With the throttle linkage in this position, a tang on the fast idle lever contacts the fast idle cam and causes the choke valve to open a predetermined amount. This is referred to as the choke unloader clearance.

Altitude Compensation Circuit

The altitude compensation circuit supplies the extra air necessary to lean out the air/fuel mixture at high altitudes. The compensation circuit parallels the main carburetor intake circuit (fig. 1J-122). At the top, a small choke valve controls the airflow when the main choke is is

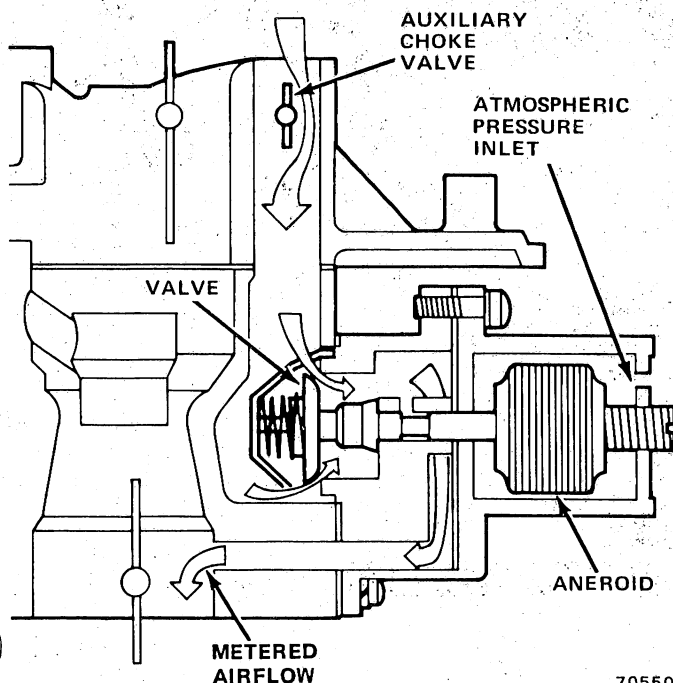

Fig. 1J-122 Altitude Compensation Circuit

70550

closed. Air flows down through a passage in the main body into a plenum chamber located adjacent to the two main venturi bores. A spring-loaded valve regulates the amount of air passed from the plenum into the compensator body. Air flows from the compensator body through two air passages bored into the main venturi tubes.

The opening and closing of the valve in the compensator body is controlled by an aneroid that reacts to the atmospheric pressure. At the lower atmospheric pressure of higher altitudes, the aneroid pushes on the end of the compensator valve stem, opening the valve. At lower altitudes, the aneroid relaxes, automatically closing the valve.

The aneroid is calibrated during factory assembly and is not adjustable. Do not tamper with the hex-head plug on the aneroid.

CARBURETOR REPLACEMENT

Removal

- (1) Remove air cleaner.
- (2) Remove throttle cable from throttle lever. Disconnect vacuum hoses, pullback spring, choke filtered air tube, choke heater element wire connector, solenoid wire connector, PCV valve hose, inline fuel filter and choke heated air tube at carburetor.

- (3) Remove carburetor retaining nuts. Remove carburetor and gasket from intake manifold.

Installation

- (1) Clean gasket mounting surfaces of spacer and carburetor. Position gasket on intake manifold. Position carburetor on spacer and gasket and install nuts. To prevent leakage, distortion or damage to carburetor body flange, alternately tighten nuts in crisscross pattern.

- (2) Connect in-line fuel filter, throttle cable, choke heated air tube, PCV valve hose, pullback spring, choke heater element wire connector, solenoid wire connector, choke filtered air tube and vacuum hoses.

- (3) Adjust engine idle speed. Refer to Chapter 1A—General Service and Diagnosis for procedures.

CARBURETOR OVERHAUL

The following procedure applies to a complete overhaul with the carburetor removed from the engine.

A complete disassembly is not necessary when performing routine service adjustments. In most instances, service adjustments of individual circuits may be accomplished without removing the carburetor from the engine. Refer to Service Adjustment Procedures.

A complete carburetor overhaul includes disassembly, thorough cleaning, inspection, and replacement of all gaskets and worn or damaged parts. Refer to figure 1J-123 for parts identification.

1. MODULATOR COVER (IF EQUIPPED)
2. MODULATOR RETAINING SCREW (3) (IF EQUIPPED)
3. PIVOT PIN
4. MODULATOR ARM
5. CHOKE VALVE RETAINING SCREW (2)
6. CHOKE VALVE
7. CHOKE SHAFT
8. AIR HORN
9. AIR HORN RETAINING SCREW (4)
10. AIR HORN GASKET
11. FLOAT AND LEVER ASSEMBLY
12. FLOAT SHAFT RETAINER
13. FLOAT SHAFT
14. NEEDLE RETAINING CLIP
15. CURB IDLE ADJUSTING SCREW
16. CURB IDLE ADJUSTING SCREW SPRING
17. THROTTLE SHAFT AND LEVER ASSEMBLY
18. DASHPOT
19. DASHPOT LOCKNUT
20. DASHPOT BRACKET
21. DASHPOT BRACKET RETAINING SCREW
22. ADJUSTING SCREW
23. CARRIAGE
24. ELECTRIC SOLENOID
25. MOUNTING BRACKET
26. THROTTLE VALVE RETAINING SCREW (4)
27. THROTTLE VALVE (2)
28. NEEDLE AND SEAT ASSEMBLY
29. NEEDLE SEAT GASKET
30. MAIN JET (2)
31. MAIN BODY
32. ELASTOMER VALVE
33. PUMP RETURN SPRING
34. PUMP DIAPHRAGM
35. PUMP LEVER PIN
36. PUMP COVER
37. PUMP ROD
38. PUMP ROD RETAINER
39. PUMP LEVER
40. BOWL VENT BELLCRANK
41. FUEL INLET FITTING
42. POWER VALVE GASKET
43. POWER VALVE
44. POWER VALVE COVER GASKET
45. POWER VALVE COVER
46. POWER VALVE COVER RETAINING SCREW (4)
47. IDLE LIMITER CAP (2)
48. IDLE MIXTURE SCREW (2)
49. IDLE MIXTURE SCREW SPRING (2)
50. RETAINER
52. FAST IDLE LEVER RETAINING NUT
53. FAST IDLE LEVER PIN
54. RETAINER
55. LEVER AND SHAFT
56. FAST IDLE CAM ROD
57. CHOKE SHIELD
58. CHOKE SHIELD RETAINING SCREW (2)
59. PISTON PASSAGE PLUG
60. HEAT PASSAGE PLUG
61. CHOKE COVER RETAINING CLAMP
62. CHOKE COVER RETAINING SCREW (3)
63. CHOKE COVER AND COIL
64. CHOKE COVER GASKET
65. COIL LEVER RETAINING SCREW
66. COIL LEVER
67. CHOKE HOUSING RETAINING SCREW (3)
68. CHOKE HOUSING
69. CHOKE SHAFT BUSHING
70. FAST IDLE SPEED ADJUSTING SCREW
71. FAST IDLE LEVER
72. FAST IDLE CAM
73. CHOKE HOUSING GASKET
74. PUMP DISCHARGE CHECK BALL
75. PUMP DISCHARGE WEIGHT
76. BOOSTER VENTURI GASKET
77. BOOSTER VENTURI ASSEMBLY
78. AIR DISTRIBUTION PLATE
79. PUMP DISCHARGE SCREW
80. RETAINER
81. CHOKE ROD
82. CHOKE LEVER RETAINING SCREW
83. CHOKE PLATE LEVER
84. CHOKE ROD SEAL
85. STOP SCREW
86. MODULATOR RETURN SPRING (IF EQUIPPED)
87. MODULATOR DIAPHRAGM ASSEMBLY (IF EQUIPPED)

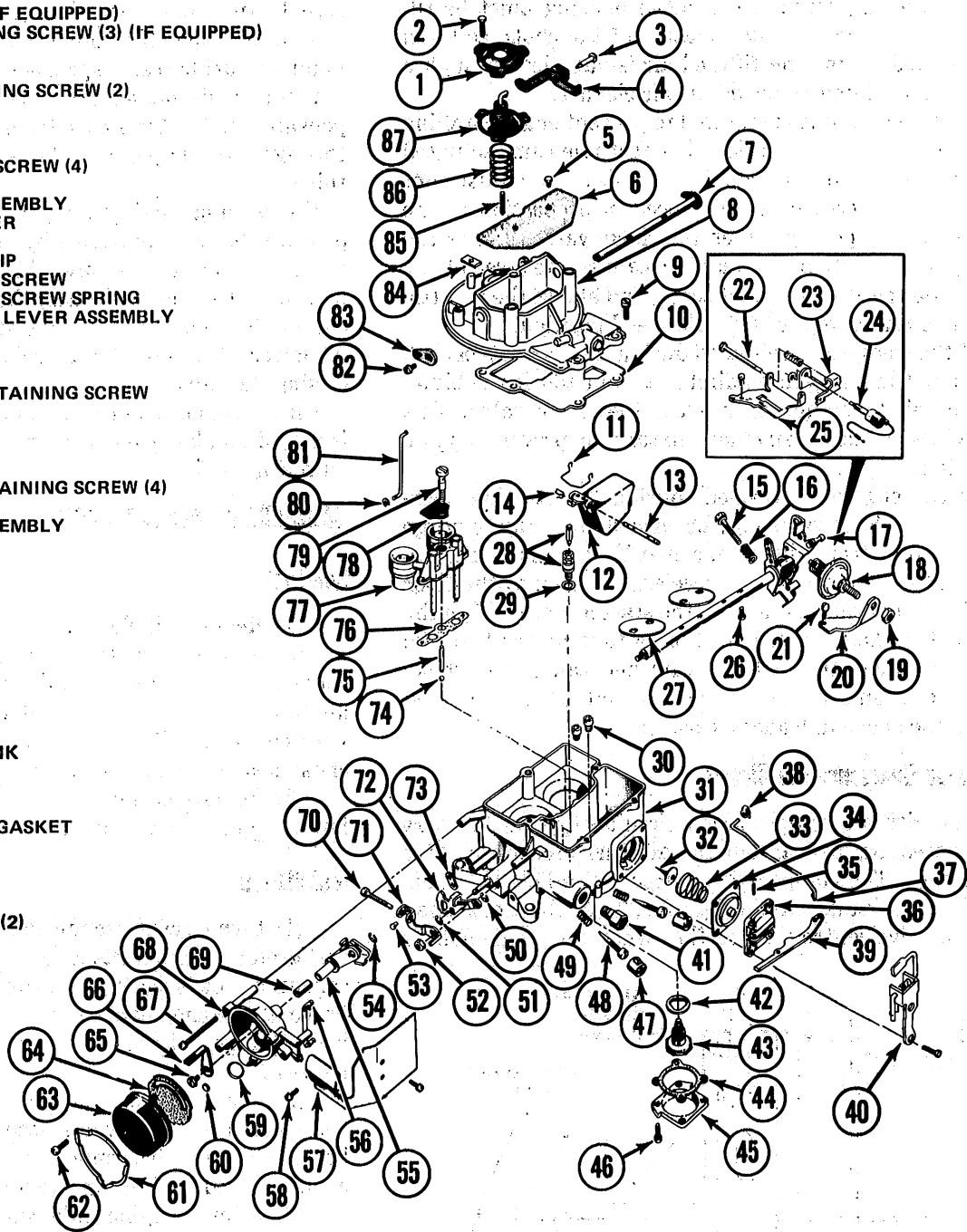

74. PUMP DISCHARGE CHECK BALL
75. PUMP DISCHARGE WEIGHT
76. BOOSTER VENTURI GASKET
77. BOOSTER VENTURI ASSEMBLY
78. AIR DISTRIBUTION PLATE
79. PUMP DISCHARGE SCREW
80. RETAINER
81. CHOKE ROD
82. CHOKE LEVER RETAINING SCREW
83. CHOKE PLATE LEVER
84. CHOKE ROD SEAL
85. STOP SCREW
86. MODULATOR RETURN SPRING (IF EQUIPPED)
87. MODULATOR DIAPHRAGM ASSEMBLY (IF EQUIPPED)

Fig. 1J-123. Parts Identification—Motorcraft Model 2150 Carburetor

NOTE: When using an overhaul kit, use all parts included in the kit.

NOTE: Flooding, hesitation on acceleration, and other performance problems are in many instances caused by the presence of debris, water, or other foreign matter in the carburetor. To aid in diagnosing the cause of a problem, carefully remove the carburetor from the engine without removing the fuel from the bowl. Examine the contents of the bowl for contamination as the carburetor is disassembled.

Disassembly

- (1) Remove air cleaner anchor screw.
- (2) Remove automatic choke rod retainer from choke shaft lever.
- (3) Remove air horn attaching screws, lockwashers and carburetor identification tag. Remove air horn and air horn gasket.
- (4) Remove choke rod by loosening screw that secures choke shaft lever to choke shaft. Remove rod and plastic dust seal from air horn.
- (5) Remove choke modulator assembly, if equipped.
- (6) Remove fast idle cam retainer (fig. 1J-124).

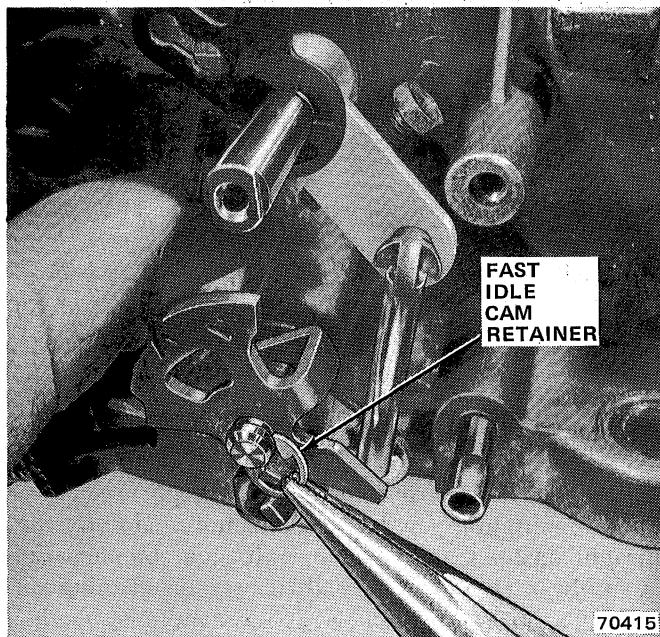

Fig. 1J-124 Fast Idle Cam Retainer

- (7) Remove choke shield.
- (8) Remove choke housing cover retaining screws and clamp, cover with coil and gasket.
- (9) Remove fast idle cam rod from fast idle cam lever.
- (10) Remove choke housing assembly retaining screws, housing assembly and gasket.
- (11) Remove fast idle cam.

(12) Remove thermostat lever retaining screw and washer. Remove choke shaft and fast idle cam lever from choke housing.

(13) Pry float shaft retainer from fuel inlet seat (fig. 1J-125). Remove float, float shaft retainer and fuel inlet needle assembly. Remove retainer and float shaft from float lever.

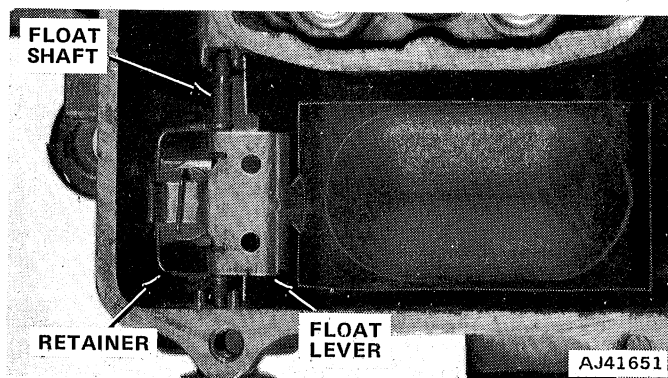

Fig. 1J-125 Float Assembly

(14) Remove fuel inlet needle seat and gasket. Remove main jets with Main Metering Jet Removal Tool J-10174-01 (fig. 1J-126).

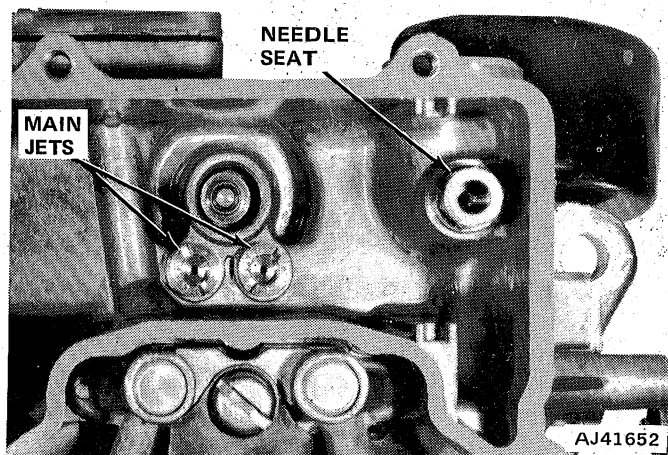

Fig. 1J-126 Interior View of Fuel Bowl

(15) Remove accelerator pump discharge screw, air distribution plate, booster venturi and gasket (fig. 1J-127). Do not attempt to remove tubes from venturi assembly. Invert main body and catch accelerator pump discharge weight and ball.

(16) Disconnect accelerator pump operating rod from overtravel lever. Remove rod and retainer.

(17) Remove accelerator pump cover attaching screws. Remove bowl vent bell crank and bracket assembly, accelerator pump cover, diaphragm assembly and spring (fig. 1J-128).

(18) Remove elastomer valve by grasping firmly and pulling out.

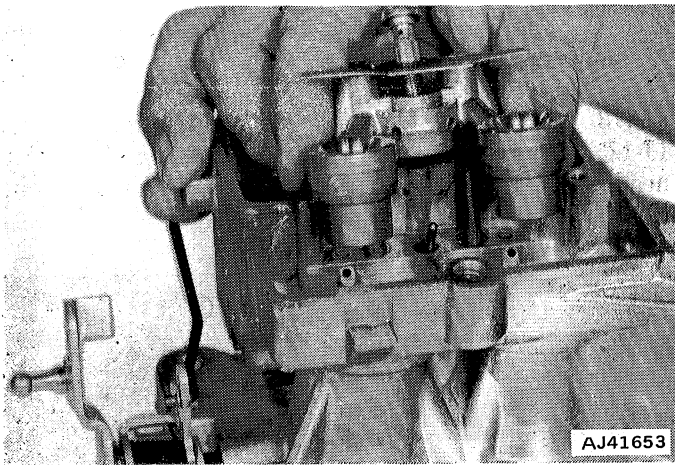

Fig. 1J-127 Booster Venturi Assembly

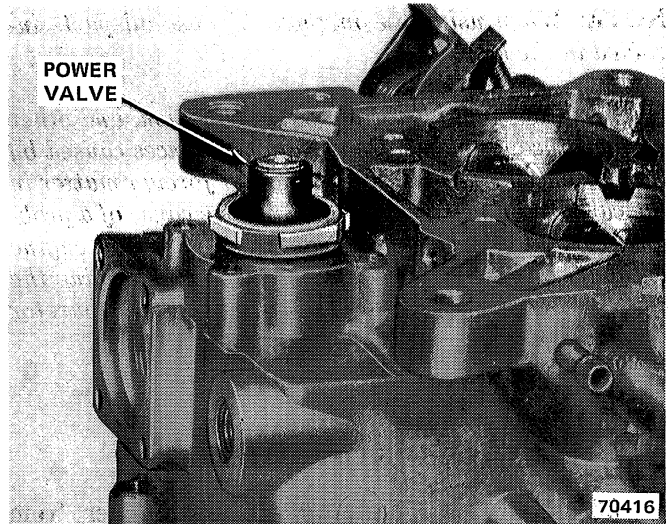

Fig. 1J-129 Power Valve

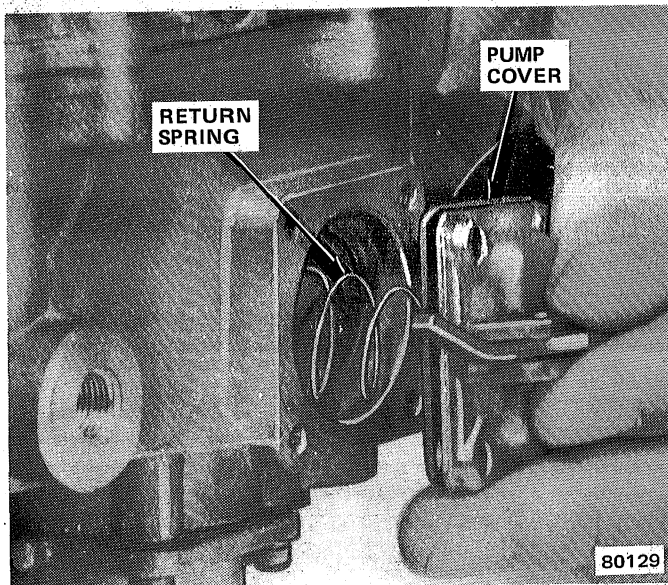

Fig. 1J-128 Accelerator Pump Assembly

NOTE: If the elastomer valve tip breaks off during removal, ensure the tip is removed from the fuel bowl. The elastomer valve must be replaced whenever it has been removed from the carburetor.

(19) Invert main body and remove power valve cover, gasket and screws. Remove power valve (fig. 1J-129). Remove and discard power valve gasket.

(20) Remove attaching screws and remove compensation assembly and gasket from carburetor body.

(21) Remove aneroid-to-chamber screws. Remove gasket and aneroid from chamber.

NOTE: If it is necessary to remove the idle mixture screws because air pressure and soaking did not completely clean the air passages, remove caps concealing screws. Count and record number of turns necessary to lightly seat mixture screws for assembly reference. Remove idle mixture screws.

(22) Remove solenoid.

Cleaning and Inspection

Debris, gum, water and carbon contamination in the carburetor or on the exterior moving parts of the carburetor are often responsible for unsatisfactory engine performance. Efficient carburetion depends upon careful cleaning and inspection.

The cleaning and inspection procedure listed below does not involve the replacement parts included in the carburetor overhaul/repair kit. Install all gaskets and parts included in the repair kit when the carburetor is assembled. Discard the original gaskets and replaced parts.

CAUTION: Do not use a wire brush to clean any parts. Do not use a drill or wire to clean any openings or passages in the carburetor. A drill or wire may enlarge the hole or passage and change the calibration of the carburetor.

CAUTION: Do not immerse any part of the altitude compensation assembly in cleaning solvent. Wipe all parts with clean, lint-free cloths.

Wash all the carburetor parts except accelerator pump diaphragm, power valve, vacuum modulator diaphragm dashpot assembly and altitude compensation assembly in clean commercial carburetor cleaning solvent. If a commercial solvent is not available, use lacquer thinner or denatured alcohol. If a commercial cleaner is used, rinse the parts in hot water to remove all traces of the cleaning solvent, then dry them with compressed air. Wipe all parts that cannot be immersed in solvent with a clean, soft, dry cloth. Ensure all sediment, gum, carbon and other foreign matter is removed from all parts. Force compressed air through all passages of the carburetor.

Examine the choke shaft for wear and excessive looseness or a binding condition. Inspect the choke shaft and polish with fine crocus cloth or equivalent material.

Inspect the choke valve for nicked edges and for ease of operation and repair if necessary. Ensure all carbon and foreign residue has been removed from the automatic choke housing. Examine the throttle shaft for excessive

looseness or binding in its bore. Examine the throttle valves for burrs that could prevent proper closure. Inspect the main body, air horn, booster venturi assemblies, choke housing and choke cover, power valve cover and accelerator pump cover for cracks. Replace the float if the arm needle contact surface is grooved. If the float is serviceable, polish the needle contact surface of the arm with crocus cloth or equivalent material. Replace float shaft if worn. Replace all screws and nuts that have stripped threads. Replace all distorted or broken springs. Inspect all gasket mating surfaces for nicks and burrs. Repair or replace any parts that have a damaged gasket surface.

With the aneroid removed from the chamber, spring tension should fully close the air valve. Examine the position of the spring in the retainer and ensure it is properly seated (fig. 1J-130). Inspect the rubber seal on the valve stem. Examine the aneroid assembly and ensure that the atmospheric pressure inlet hole is free of debris.

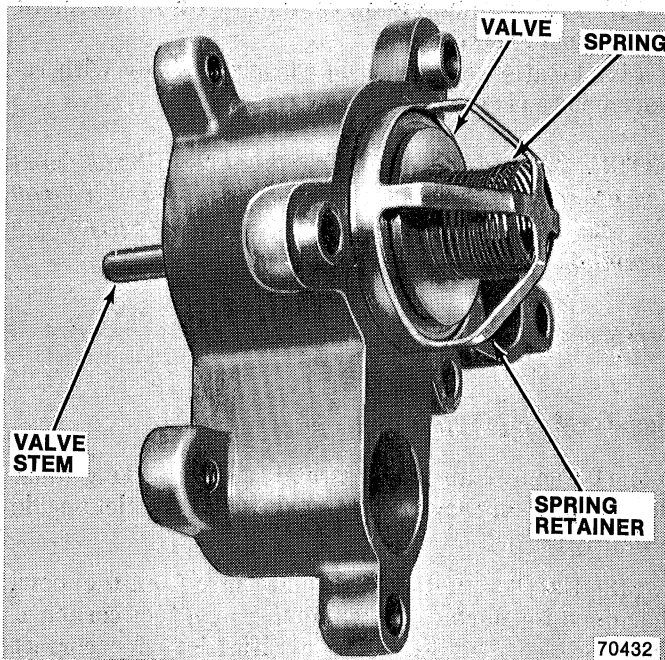

Fig. 1J-130 Altitude Compensator

Assembly

Refer to figure 1J-123 for parts identification.

NOTE: Ensure all holes in the replacement gaskets have been properly punched and that no foreign material has adhered to the gaskets. Inspect vacuum diaphragms for tears or cuts.

- (1) Install fast idle speed adjustment screw and spring on fast idle lever.
- (2) Install solenoid.

(3) Place fast idle lever assembly on throttle shaft and install retaining washer and nut.

(4) Lubricate tip of replacement elastomer valve and insert tip into accelerator pump cavity center hole.

(a) Using needlenose pliers, grasp valve tip from inside fuel bowl.

(b) Pull valve in until it seats in pump cavity wall. Cut off tip forward of retaining shoulder.

(c) Remove tip from bowl.

(5) Install accelerator pump diaphragm return spring in chamber depression. Insert diaphragm assembly in cover, place cover and diaphragm assembly into position on main body and install two right-side cover screws.

(6) Position bowl vent bell crank and bracket assembly over accelerator pump cover left-side holes. Ensure vent lever is positioned behind pump lever. Install retaining screws.

(7) Insert accelerator pump operating rod into in-board hole of accelerator pump actuating lever.

(8) Position accelerator pump operating rod retainer over hole 3 in overtravel lever.

(9) Invert main body and install power valve and replacement gasket. Tighten valve securely.

(10) Install power valve cover and replacement gasket.

NOTE: Install the power valve cover with the extensions adjacent to the main body to provide entry for the slots on the idle mixture adjustment screw caps.

(11) If removed, install idle mixture adjustment screws and springs. Turn screws in gently with fingers until they lightly seat, then back off number of turns recorded during removal for preliminary idle fuel mixture adjustment.

NOTE: Do not install idle mixture screw caps at this time.

(12) Install main jets.

(13) Install fuel inlet seat and replacement gasket. Install fuel inlet needle assembly in fuel inlet seat. Fuel inlet needles and seats are matched assemblies. Ensure correct needle and seat are assembled together.

(14) Slide float shaft into float lever. Position float shaft retainer on float shaft.

(15) Install float damper spring with short wire under float lever (fig. 1J-131).

(16) Insert float assembly into fuel bowl and hook float lever tab under fuel inlet needle assembly. Insert float shaft into its guides at sides of fuel bowl.

(17) Press float shaft retainer into groove on fuel inlet needle seat and adjust float level. Refer to Service Adjustment Procedures.

(18) Drop accelerator pump discharge ball into passage in main body.

(19) Position replacement booster venturi gasket and booster venturi in main body.

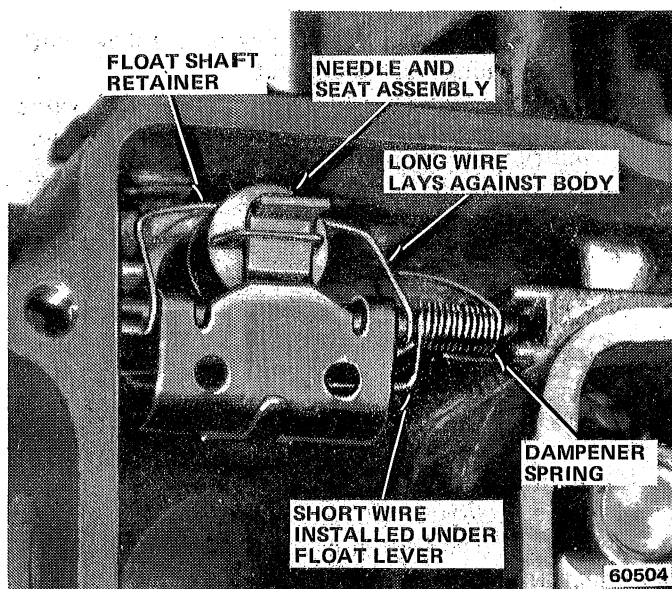

Fig. 1J-131 Damper Spring Installation

(20) Drop accelerator pump discharge weight into booster on top of discharge ball.

(21) Install air distribution plate and accelerator pump discharge screw and tighten screw.

(22) Position fast idle cam lever on choke shaft. Install retainer.

NOTE: *The bottom of the fast idle cam lever adjustment screw must rest against the tang on the choke shaft.*

(23) Insert choke shaft into the rear of choke housing. Position choke shaft so that hole in shaft is on left side of choke housing.

(24) Install fast idle cam rod on fast idle cam lever.

(25) Install fast idle cam and retainer to hub on main body.

(26) Place choke housing vacuum pickup port-to-main body gasket on choke housing flange.

(27) Wipe choke shaft bushing clean (small piece of plastic material), and install in choke shaft bore in choke housing.

(28) Position choke housing on main body and install choke housing attaching screws.

(29) Install retainer to fast idle cam rod at fast idle cam.

(30) Install coil lever.

(31) Install choke housing cover, gasket, retainer and screws. Turn choke cover 1/4 turn rich and tighten one retaining screw.

(32) Install choke shield.

(33) Insert choke rod into choke valve lever. Lower end of rod must protrude through air horn.

(34) Install choke valve lever on choke shaft and tighten screw.

(35) Install plastic dust shield on choke rod.

(36) Position main body gasket on main body.

(37) Position air horn on main body and gasket so that choke valve rod fits through opening in main body. Ensure plastic shield is free to slide.

(38) Insert end of choke valve rod into choke valve lever.

(39) Install air horn attaching screws and carburetor identification tag. Tighten attaching screws.

(40) Attach choke valve rod and retainer on choke shaft lever.

(41) Install air cleaner anchor screw.

(42) If equipped, install modulator diaphragm return spring in recess of air horn. Position modulator cover over diaphragm assembly and engage piston rod with keyed slot of modulator arm. Place diaphragm and cover over return spring and install cover retaining screws.

(43) Adjust initial choke valve clearance. Refer to Service Adjustment Procedures.

(44) Adjust fast idle cam linkage. Refer to Service Adjustment Procedures.

(45) Adjust choke unloader clearance. Refer to Service Adjustment Procedures.

(46) Loosen choke housing cover screw and align cover index with specified notch. Refer to Specifications. Tighten all cover screws.

(47) Position aneroid on chamber with replacement gasket. Install screws.

(48) Position assembly on carburetor body with replacement gasket. Install screws.

NOTE: *There are no adjustments for the altitude compensator assembly. Do not attempt to turn the fitting on the aneroid. It is adjusted and sealed during factory assembly.*

SERVICE ADJUSTMENT PROCEDURES

Float Level Adjustment—Dry

(1) Remove air horn assembly and gasket. Raise float by pressing down on float tab until fuel inlet needle is lightly seated.

(2) Use T-scale to measure distance from fuel bowl machined top surface to flat surface on either corner of float at free end. Refer to Specifications for correct dimension.

(3) Bend float tab to adjust. Hold fuel inlet needle off its seat while adjusting to prevent damage to Viton-tipped needle (fig. 1J-132).

Float Level Adjustment—Wet

WARNING: *Exercise extreme caution when performing this procedure. Fuel vapor is present when carburetor air horn is removed. Extinguish cigarettes and other smoking materials.*

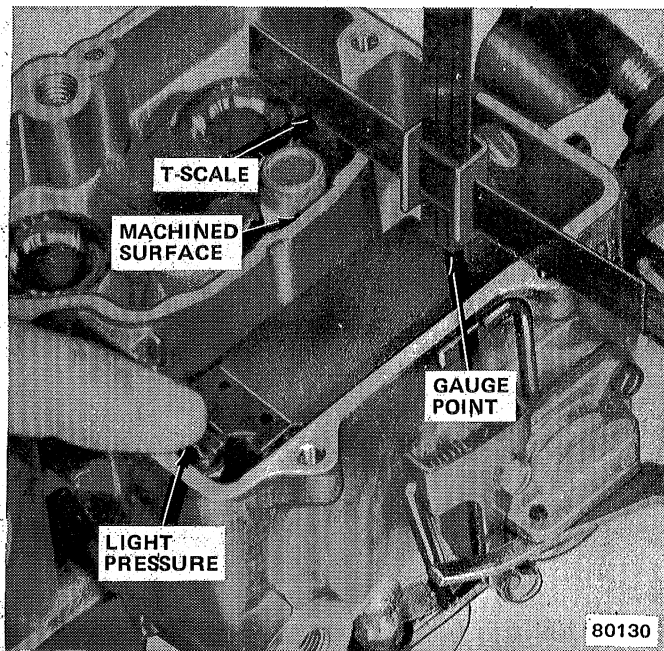

Fig. 1J-132 Float Level Adjustment—Dry

(1) Position vehicle on flat, level surface and warm engine to normal operating temperature. Turn engine off. Remove carburetor air cleaner assembly and anchor screw.

(2) Remove air horn attaching screws and carburetor identification tag. Temporarily place air horn and gasket in position on carburetor main body and start engine. Let engine idle one minute, then turn engine off and move air horn aside. Remove air horn gasket to provide access to float assembly.

(3) Use T-scale to measure vertical distance from top machined surface of carburetor main body to level of fuel in fuel bowl (fig. 1J-133). Measure at least 1/4 inch away from vertical surface to assure accurate indication because top surface of fuel is concave (higher at edges than in center). Measure fuel level at exact point of contact between scale and fuel. Refer to Specifications for correct fuel level (wet) dimension.

(4) To adjust fuel level, bend float tab (contacting fuel inlet valve) upward in relation to original position to raise fuel level, and downward to lower it. Each time adjustment is made to float tab to alter fuel level, place gasket and air horn on carburetor, start engine and permit to idle one minute to stabilize fuel level. Turn engine off and measure fuel level after each adjustment until specified level is obtained.

(5) Install replacement air horn gasket, air horn assembly, carburetor identification tag and attaching screws. Ensure plastic dust seal on choke operating rod is positioned correctly and does not cause rod to bind. Tighten screws. Install air cleaner anchor screw and tighten.

(6) Adjust idle speed. Refer to Idle Speed Adjustment.

(7) Install air cleaner.

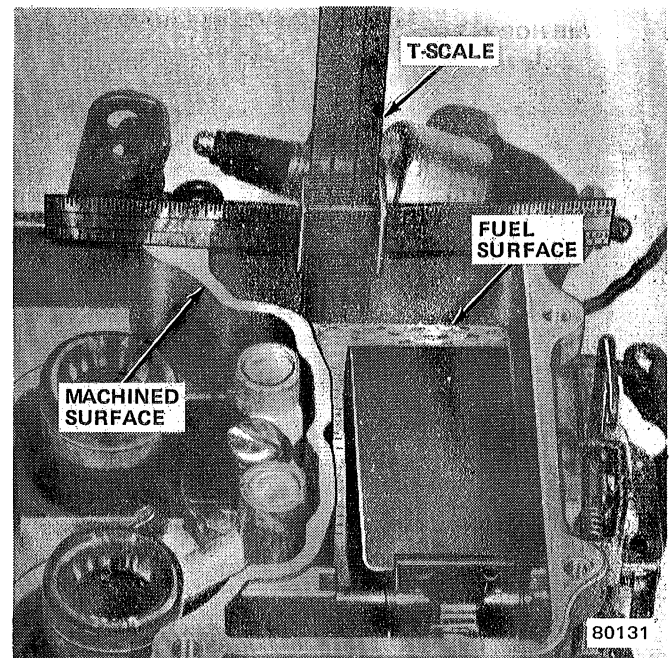

Fig. 1J-133 Float Level Adjustment—Wet

Initial Choke Valve Clearance and Fast Idle Cam Linkage Adjustments

(1) Loosen choke cover retaining screws.

(2) Open throttle and rotate choke cover until choke valve is held closed. Tighten one retaining screw.

(3) Close throttle with fast idle speed adjustment screw on top step of cam.

(4) Apply vacuum to hold choke diaphragm against setscrew. Do not press on links.

NOTE: If vacuum is applied to the choke diaphragm with a hand pump, an air leak may be noticed. This is normal.

(5) Measure clearance between lower edge of choke valve and air horn (fig. 1J-134).

(6) Adjust clearance by turning screw located at rear of diaphragm housing.

(7) Push down on fast idle cam lever until fast idle speed adjustment screw is in contact with second step (index) and against shoulder of high step.

(8) Measure clearance between upper edge of choke valve and air horn wall. Refer to Specifications for correct dimension.

(9) Adjust by turning fast idle cam lever screw (fig. 1J-135).

(10) Loosen choke cover retaining screw and adjust choke by turning cover until index is aligned with correct notch on housing. Refer to Specifications.

(11) Position choke cover shield and install retaining screws.

Choke Unloader Adjustment

(1) Hold throttle fully open and apply pressure on choke valve toward closed position.

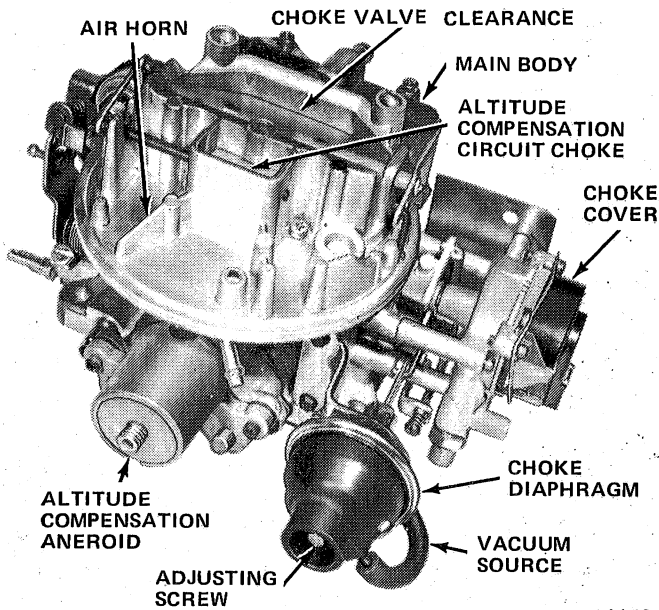

81153

Fig. 1J-134 Initial Choke Valve Clearance Adjustment

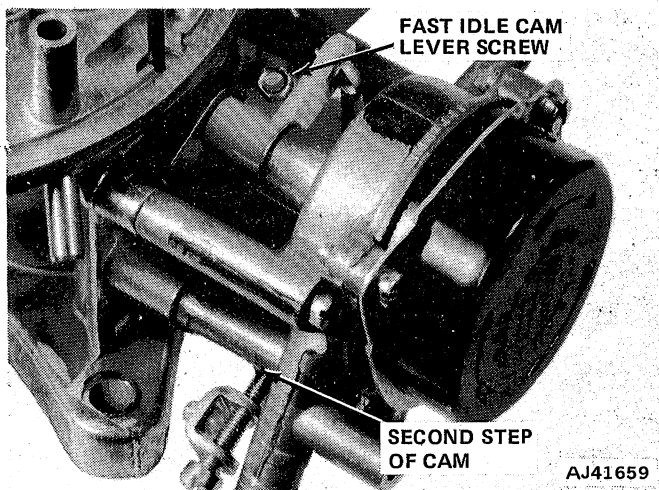

AJ41659

Fig. 1J-135 Fast Idle Cam Linkage Adjustment

(2) Measure clearance between lower edge of choke valve and air horn wall. Refer to Specifications for correct dimension.

CAUTION: Do not bend the unloader tang downward from a horizontal plane.

(3) Adjust by bending unloader tang that contacts fast idle cam (fig. 1J-136). Bend toward cam to increase clearance and away from cam to decrease clearance.

(4) After completing adjustment, open throttle until unloader tang is directly below fast idle cam pivot. There must be exactly 0.070-inch (1.8 mm) clearance between unloader tang and edge of fast idle cam (fig. 1J-137).

(5) Operate throttle and inspect unloader tang to ensure it does not bind, contact or stick on any part of

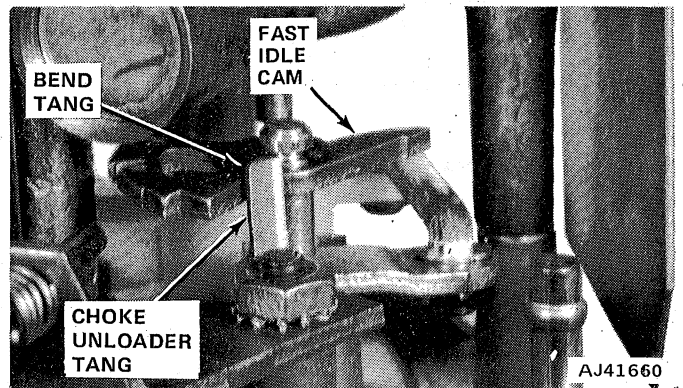

AJ41660

Fig. 1J-136 Choke Unloader Adjustment

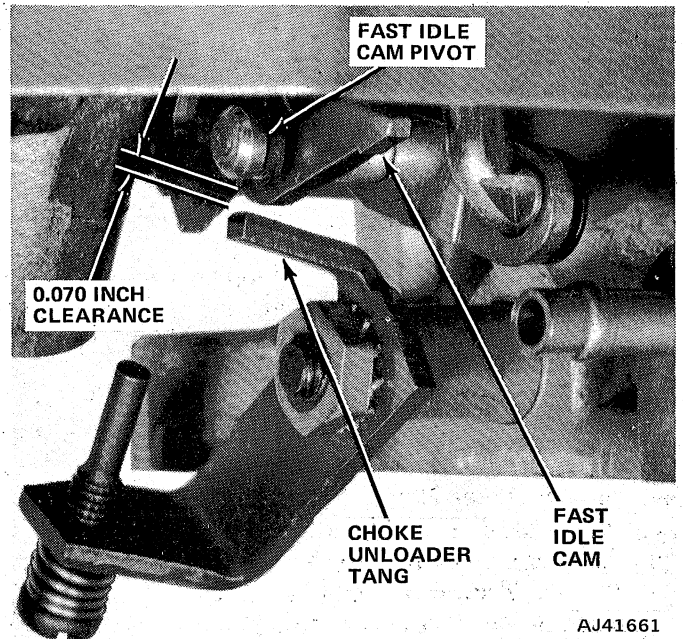

AJ41661

Fig. 1J-137 Unloader—Fast Idle Cam Clearance

carburetor casting or linkage. After carburetor installation, inspect for full throttle opening when throttle is operated from inside vehicle. If full throttle opening is not obtainable, it may be necessary to remove excess padding under floor mat or reposition throttle cable bracket located on engine.

Automatic Choke Adjustment

Loosen choke housing cover retaining screws and rotate cover in the desired direction as indicated by the arrow on the face of the cover. Refer to Specifications for the correct position (notch). The specified position will be satisfactory for most driving conditions.

NOTE: The richer the choke setting the longer the coil tension exerts force against the linkage and holds the choke in a closed position. As heated incoming air and the electric heater warm the coil, the tension is reduced and fast idle cam weight gradually moves the choke linkage in the opposite direction.

Accelerator Pump Stroke Adjustment

The specified accelerator pump stroke has been selected to help maintain the exhaust emission level of the engine within regulations. The unused adjustment holes permit adjusting the stroke for a specific engine application and ambient location. The primary throttle shaft lever (overtravel lever) has four holes and the accelerator pump link has two holes (fig. 1J-138).

For normal operating conditions, the accelerator pump operating rod should be in the third hole (away from the lever pivot) of the overtravel lever and the inboard hole (closest to the pump plunger) in the accelerator pump lever. In extremely hot climate regions, the pump stroke may be shortened to provide smoother acceleration by placing the pump rod in the second hole of the overtravel lever. In extremely cold climate regions, the pump stroke may be increased to provide smoother acceleration by placing the pump rod in the fourth hole of the overtravel lever.

- (1) Remove retaining clip from operating rod.
- (2) Position clip over specified hole in overtravel lever. Insert operating rod end through clip and overtravel lever. Snap release clip over rod end.

Idle Speed and Mixture Adjustments

Idle Speed Adjustment

NOTE: When adjusting idle speed, put manual transmission in Neutral. Put automatic transmission in Drive.

WARNING: Set parking brake firmly. Do not accelerate engine.

- (1) Connect tachometer, start engine and warm to normal operating temperature. Choke must be off.

WARNING: Use extreme caution when engine is operating. Do not stand in direct line with fan. Do not put hands near pulleys, belts or fan. Do not wear loose clothing.

- (2) Turn hex-head screw on solenoid carriage to obtain 600 rpm.

- (3) Disconnect solenoid wire connector and adjust curb idle screw to obtain 500 rpm curb idle speed.

- (4) Connect solenoid wire connector.

- (5) If equipped with dashpot: with throttle at curb idle position, fully depress dashpot stem and measure clearance between stem and throttle lever. Clearance should be 0.032 inch (0.813 mm). Adjust by loosening locknut and turning dashpot.

Idle Mixture Adjustment

NOTE: The idle mixture should be adjusted only if the mixture screws were removed or altered during major carburetor overhaul.

- (1) Connect tachometer. Start engine and warm to normal operating temperature.

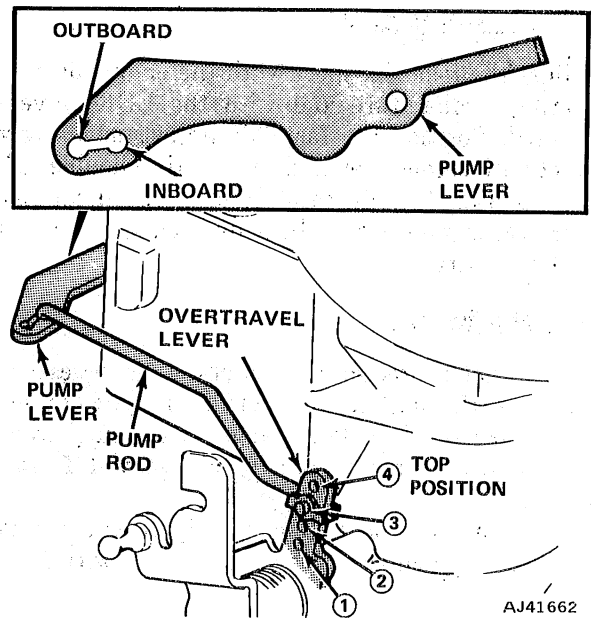

Fig. 1J-138 Accelerator Pump Stroke Adjustment

NOTE: Use a tachometer with an expanded scale of 400-800 or 0-1000 rpm. Inspect tachometer periodically to ensure accuracy within two percent.

- (2) Position automatic transmission in Drive, manual in Neutral.

- (3) Adjust idle speed to specified rpm. Use Set-To value.

- (4) Turn mixture adjustment screws leaner (clockwise) until perceptible loss of rpm is noted.

- (5) Turn mixture screws richer (counterclockwise) until highest rpm is obtained. Do not turn screws any further than position where highest rpm is first obtained. This is referred to as lean best idle.

NOTE: Engine speed will increase above curb idle speed an amount that corresponds approximately to the lean drop specification.

- (6) As final adjustment, turn both idle mixture screws clockwise in small, equal amounts until specified drop is achieved.

NOTE: If the final rpm differs more than ± 30 rpm from the originally adjusted curb idle speed, adjust curb idle to specification and repeat steps (5) and (6).

- (7) Install mixture screw caps removed during overhaul. Use care to prevent disturbing mixture adjustment while installing caps.

Model 2150 Carburetor Idle Drop

Engine	Transmission	Idle Drop RPM
360 2V	Manual	50
	Automatic	20

Fast Idle Speed Adjustment

Adjust the fast idle speed with the engine at normal operating temperature and with the EGR valve disconnected. Position the fast idle adjustment screw in contact with second step and against the shoulder of the high step of the fast idle cam. Refer to Specifications for the correct engine rpm. Adjust by turning the fast idle adjustment screw.

- (5) Wipe fast idle cam clean.
- (6) Install choke housing over choke shaft and install housing screws.
- (7) Install choke lever and screw.
- (8) Install choke cover, connect heater connector wire and adjust to specification.

Bowl Vent Adjustment

This is not a precise adjustment. It is necessary to ensure that the mechanical bowl vent is open at idle and closed at greater throttle openings. It may be performed with the carburetor installed or removed from the engine.

- (1) If installed on engine, turn ignition off. Ensure fast idle adjustment screw is not in contact with fast idle cam.
- (2) Manually depress stem of bowl vent valve and insert gauge between valve stem and flat on end of bellcrank. Refer to Specifications for clearance dimension.
- (3) If clearance is not correct, bend bellcrank as required. Do not bend lever on accelerator pump.

CHOKE MECHANISM SERVICE

The choke mechanism may be serviced without removing the carburetor from the engine. If the choke or linkage binds, sticks, or does not operate smoothly, perform the following.

- (1) Disconnect heater wire connector and remove choke cover.
- (2) Remove choke lever screw and lever.
- (3) Remove choke housing. Slide out choke shaft. Remove thin plastic bushing.
- (4) Polish shaft with crocus cloth. Wipe bushing clean and insert into housing.

SPECIFICATIONS

Model 2150 Carburetor Calibrations (Inches)

	2RHM2	2RHA2
Throttle Bore Size	1.562	1.562
Main Venturi Size	1.21	1.21
Fuel Inlet Diameter	0.101	0.101
Low Speed Jet (Tube)	0.033	0.036
Economizer	0.052	0.061
Idle Air Bleed	0.086	0.086
Main Jet Number	55	55
High Speed Bleed	0.055	0.055
Power Valve Timing (Inches of Hg)		
—First Stage	9.0	9.0
—Second Stage	5.0	5.0
Accelerator Pump Jet	0.024	0.024
Vacuum Spark Port		
—Height	0.050	0.050
—Width	0.085	0.085
Choke Heat Bypass	0.114	0.114
Choke Heat Inlet Restriction	0.076	0.076
Choke Vacuum Restriction	0.089	0.089

80600

Model 2150 Carburetor Specifications

List Number	Application	Float Level (Wet) (Inches)		Float Level (Dry)	Initial Choke Valve Clearance (Inches)		Fast Idle Cam Setting (Inches)		Automatic Choke Cover Setting (Notches Rich)		Choke Unloader (Inches)	Fast Idle Speed ①		Bowl Vent Clearance	Choke Bimetal ID
		Set To	OK Range		Set To	OK Range	Set To	OK Range	Set To	OK Range		Set To	OK Range		
2RHM2	360 Manual 49 State	0.93	0.868 to 0.992	Measure from machined surface to a point on float 1/8-inch from tip. Needle Seated.	0.116	0.098 to 0.140	0.076	0.061 to 0.091	1	1/2 to 1-1/2	0.350 min.	1500	1400 to 1600	0.120	KJ
2RHA2	360 Automatic 49 State	0.93	0.868 to 0.992	21/64 in. ± 1/32 in.	0.116	0.098 to 0.140	0.076	0.061 to 0.091	1	1/2 to 1-1/2	0.350 min.	1600	1500 to 1700	0.120	KJ

① Hot with EGR valve disconnected.

80601

EXHAUST GAS RECIRCULATION (EGR) SYSTEM

	Page
EGR CTO Valve	1J-75
EGR Delay Valves	1J-77
EGR Vacuum Dump Valve	1J-76

	Page
EGR Valve	1J-73
General	1J-73
Thermal Vacuum Switch (TVS)	1J-76

GENERAL

The EGR system used on all Jeep vehicles reduces the production of oxides of nitrogen (NO_x) by introducing a metered amount of exhaust gas into the combustion chambers. Exhaust gas is inert (will not burn), therefore combustion temperature is lowered and less NO_x is produced at the lower combustion temperature.

EGR action does not occur until the engine coolant temperature has reached a calibrated level and the engine load is sufficient to permit proper EGR operation (figs. 1J-139, 140 and 141).

The EGR coolant temperature override (CTO) valve prevents EGR action until engine coolant temperature reaches a calibrated level, and the back-pressure sensor permits EGR action only at increased engine loads, improving driveability.

Depending on model applications, the following components may be used either separately or together. The Thermal Vacuum Switch (TVS) is located in the air cleaner and is controlled by air cleaner air temperature. The TVS controls the vacuum passage between the EGR CTO valve and the EGR valve. At air temperatures below the calibrated value, the TVS limits the effects of vacuum on the EGR valve. This prohibits EGR valve operation and improves cold engine driveability. The EGR Vacuum Dump Valve is connected between the EGR vacuum source and the EGR valve. At the calibrated vacuum level, the vacuum to the EGR valve is interrupted, thereby preventing EGR operation. This valve is used to eliminate the EGR function at relatively low intake manifold vacuum levels.

EGR VALVE

The EGR valve mounts on a spacer plate located beneath the carburetor for four-cylinder engines, on the side of the intake manifold for six-cylinder engines and on a machined surface at the rear of the intake manifold on eight-cylinder engines. Exhaust gas enters the intake manifold via the cross flow cast into the cylinder head on four-cylinder engines, is drawn from the center of the exhaust manifold via a flexible tube on six-cylinder engines and from the exhaust crossover passage on eight-cylinder engines.

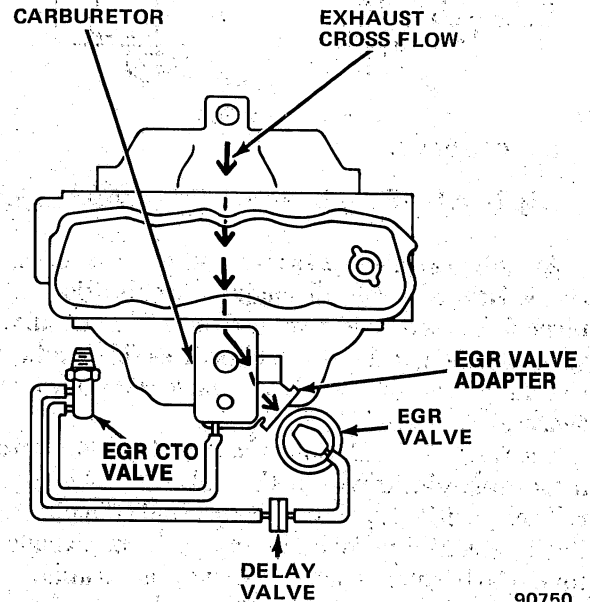

Fig. 1J-139 EGR System—Four-Cylinder Engine—Typical

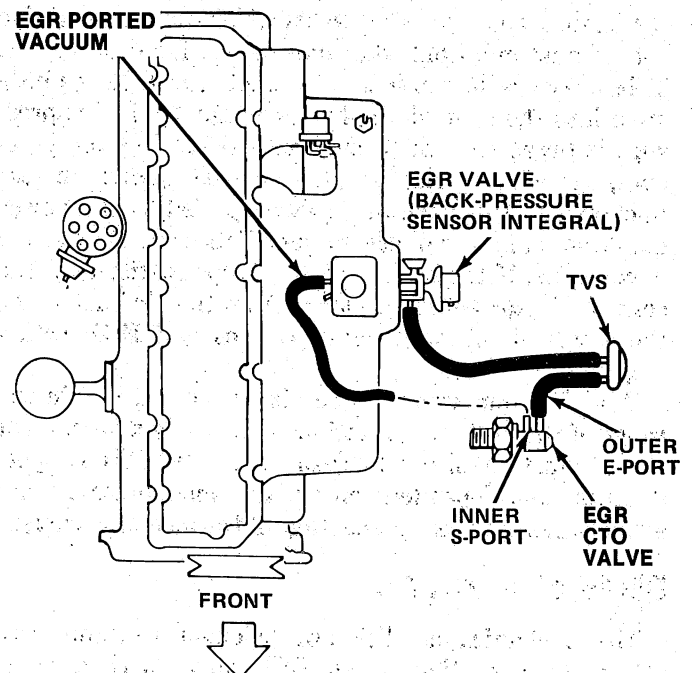

Fig. 1J-140 EGR System—Six-Cylinder Engine—Typical

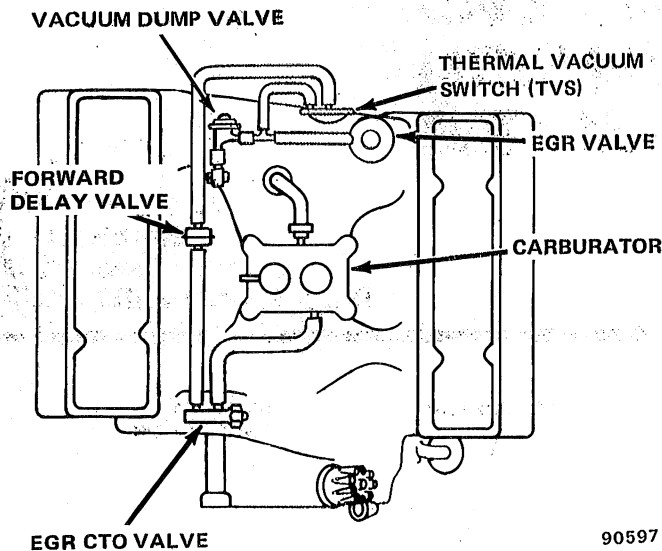

Fig. 1J-141 EGR System—Eight-Cylinder Engine—Typical

An integral back-pressure sensor is incorporated in the EGR valve for all engines. Calibration is accomplished by the selective use of different diaphragm spring loads and flow control orifices. The unit combines the functions of the EGR valve and back-pressure sensor.

The flow (recirculation) of exhaust gas is controlled by a movable pintle within the valve (fig. 1J-142). In the relaxed position, spring pressure holds the pintle against its seat, confining exhaust gases to the exhaust manifold. Carburetor ported vacuum is available at the power diaphragm to force the pintle from its seat, but this cannot occur while the air inlet valve in the power diaphragm is open.

Exhaust gas exerts pressure (back-pressure) inside the exhaust manifold whenever the engine is operating. This pressure is conducted through the hollow pintle stem into the control diaphragm chamber. If this pressure is great enough to overcome control spring pressure, the control diaphragm is moved against the air inlet valve. Full vacuum is now applied to the power diaphragm and the pintle moves off its seat. EGR action now begins. If the back-pressure drops sufficiently, the control diaphragm moves away from the air inlet valve, the power diaphragm again relaxes and EGR action stops.

When system vacuum remains constant, within the range of the unit, recirculation is primarily a function of the exhaust manifold back-pressure level. EGR operation is then dependent on exhaust back-pressure and exhaust gas is a fixed percentage of the incoming charge.

EGR Valve Functional Tests

The mechanical condition of the exhaust system may affect the operation of an EGR valve with a back-pressure sensor. Excessive back-pressure from exhaust system restrictions may create driveability problems.

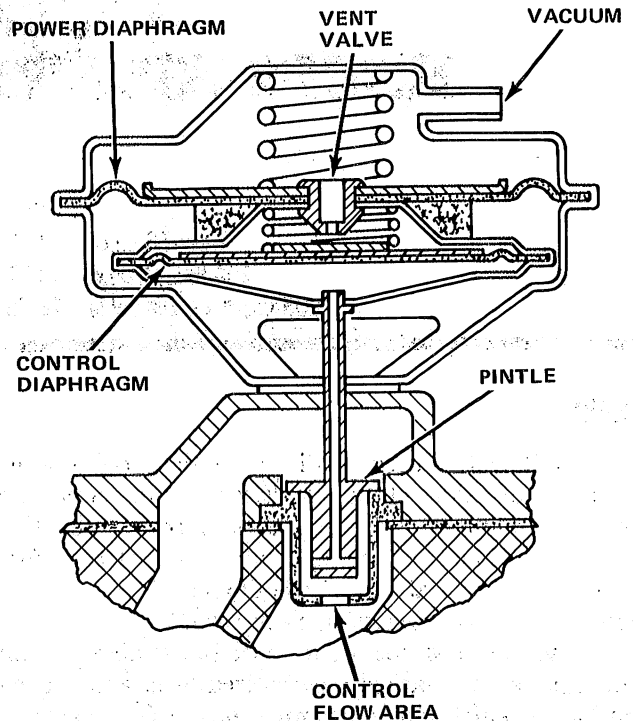

Fig. 1J-142 EGR Valve with Back-Pressure Sensor

Refer to Chapter 1K—Exhaust Systems for Restricted Exhaust System Diagnosis. Leaks from the exhaust system may decrease back-pressure enough to prevent proper EGR operation. This will increase undesirable exhaust emissions. Visually inspect the exhaust system if leaks are suspected.

Valve Opening Test

WARNING: Use extreme caution when engine is operating. Do not stand in direct line with fan. Do not put hands near pulleys, belts or fan. Do not wear loose clothing.

With the engine at normal operating temperature and at curb idle speed, rapidly open and close the throttle. The throttle should be opened sufficiently for the engine speed to attain 1500 rpm. A definite movement should be observed in the EGR valve diaphragm. If the diaphragm does not move, the probable causes are: faulty vacuum hose to the EGR valve, defective EGR valve diaphragm or defective back-pressure sensor diaphragm. Inspect vacuum hoses for air leaks.

Valve Closing Test

With the engine at normal operating temperature and at curb idle speed, manually depress the EGR valve diaphragm. This should cause an immediate decrease in engine speed, indicating that the EGR valve had been properly preventing the flow of exhaust gas during idle. If there is no change in engine rpm and the engine is

idling properly, exhaust gases are not entering the combustion chamber. The probable cause is a plugged passage between the EGR valve and the intake manifold.

If the engine idles improperly and the rpm is not noticeably affected by compressing the EGR diaphragm, the EGR valve is not preventing the flow of exhaust gas during idle. There is either a defect in the vacuum hoses, hose routings or the valve itself.

EGR Valve Replacement

Removal

- (1) For four- and eight-cylinder engines, remove air cleaner assembly.
- (2) Disconnect vacuum hoses.
- (3) Remove two retaining screws/nuts from manifold.
- (4) Remove EGR valve and gasket.
- (5) Clean EGR pintle, if necessary. Refer to EGR Valve Maintenance.
- (6) Discard gasket and clean all gasket mating surfaces.

Installation

- (1) Install gasket and EGR valve.
- (2) Install retaining screws/nuts and tighten.
- (3) Connect vacuum hoses and install air cleaner assembly, if removed.

NOTE: For correct vacuum hose routings, refer to figures 1J-139, 1J-140 and 1J-141.

EGR Valve Maintenance

Remove all carbon deposits from the stainless steel metering pintle of the valve with a wire brush. After cleaning, depress the diaphragm, cap the vacuum inlet and repeatedly open the EGR valve manually by pressing down on the diaphragm and releasing. Pintle should remain retracted. If it does not, diaphragm has a leak and valve must be replaced.

On six-cylinder engines, carbon deposits will collect more rapidly in the exhaust gas discharge passage (upper hole). If the deposits cannot be removed with a spiral-type wire brush, a 9/16-inch (14 mm) drill bit may be used. Coat the tip of the drill bit with heavy grease and use locking pliers to rotate it in the discharge passage.

EGR CTO VALVE

The EGR CTO valve is located in the coolant passage at the right rear of the cylinder head for four-cylinder engines, on the intake manifold for six-cylinder engines and either on the intake manifold adjacent to the oil filler tube or at the right rear corner of the engine adjacent to the EGR valve for eight-cylinder engines.

The inner port(s) connects by hose to the EGR port at the carburetor (ported vacuum), the outer port (E) connects to the EGR valve (or to the TVS for four-cylinder engines, fig. 1J-139).

When the coolant temperature is below the calibrated switching temperature of the CTO valve there is no vacuum applied to the EGR valve. The EGR CTO valve opens at 100°F (38°C) for four-cylinder engines and at 115°F (46°C) for six- and eight-cylinder engines, and can be identified by its black body or a black paint dab.

EGR CTO Valve Functional Test

NOTE: Engine coolant temperature must be 10°F (5.6°C) below the calibrated opening temperature.

- (1) Inspect vacuum hoses for air leaks and correct routings (figs. 1J-139, 140 and 141).
- (2) Disconnect vacuum hose at EGR valve. Connect hose to vacuum gauge.

WARNING: Use extreme caution when engine is operating. Do not stand in direct line with fan. Do not put hands near pulleys, belts or fan. Do not wear loose clothing.

- (3) Operate engine at 1500 rpm. No vacuum should be indicated on gauge. If vacuum is indicated, replace EGR CTO valve.
- (4) Idle engine until coolant temperature exceeds 100°F (38°C) for four-cylinder engines and 115°F (46°C) for six- and eight-cylinder engines.

NOTE: The coolant temperature gauge pointer will be approximately midway between the cold mark and the beginning of the normal operating temperature band when the engine coolant temperature is 115°F (46°C).

- (5) Accelerate engine to 1500 rpm. Carburetor ported vacuum should be indicated on vacuum gauge. If not, replace EGR CTO valve.

EGR CTO Valve Replacement

Removal—Four-Cylinder Engine

WARNING: Serious burns can result if pressure is not released and if hot coolant is not drained before removing valve.

- (1) Drain coolant from radiator.
- (2) Disconnect vacuum hoses.
- (3) Use open-end wrench to remove valve from right rear side of cylinder head.

Installation—Four-Cylinder Engine

- (1) Install EGR CTO valve on cylinder head.
- (2) Connect vacuum hoses.
- (3) Install coolant and purge air from cooling system.

Removal—Six-Cylinder Engine

WARNING: Serious burns can result if pressure is not released and if hot coolant is not drained before removing valve from block.

- (1) Drain Coolant from radiator.
- (2) Disconnect vacuum hoses.
- (3) Use open-end wrench to remove valve from intake manifold.

Installation—Six-Cylinder Engine

- (1) Install EGR CTO valve on intake manifold.
- (2) Connect vacuum hoses.
- (3) Install coolant and purge air from cooling system.

Removal—Eight-Cylinder Engine

WARNING: Serious burns can result if pressure is not released and if hot coolant is not drained before removing valve from intake manifold.

- (1) Drain coolant from radiator.
- (2) Remove air cleaner assembly.
- (3) If necessary, remove ignition coil bracket attaching screw and tip coil away from EGR CTO valve.
- (4) Disconnect vacuum hoses from CTO valve.
- (5) Using open-end wrench, remove valve from intake manifold or engine, as applicable.

Installation—Eight-Cylinder Engine

- (1) Install EGR CTO valve in intake manifold or engine, as applicable.
- (2) If removed, install ignition coil and bracket with attaching screw.
- (3) Connect vacuum hoses to valve.
- (4) Install air cleaner assembly.
- (5) Install coolant and purge cooling system of air.

THERMAL VACUUM SWITCH (TVS)

The Thermal Vacuum Switch (TVS) is located in the air cleaner and functions as an **On-Off** switch controlled by air cleaner air temperature (fig. 1J-143). The TVS controls the vacuum passage between the EGR CTO Valve and the EGR Valve. At air temperatures below 40° to 50°F (4.4° to 10°C), the TVS limits the vacuum applied to the EGR valve and, by doing so, prevents EGR operation. This improves cold engine driveability.

NOTE: A TVS is also used with other systems whose operation is dependent on air cleaner air temperature.

TVS Functional Test

- (1) Cool air cleaner air below TVS operational temperature limits: 40° to 50°F (4.4° to 10°C).

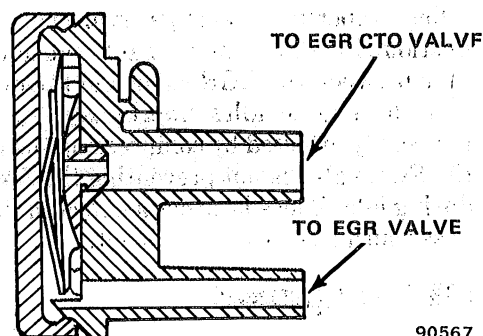

90567

Fig. 1J-143 Thermal Vacuum Switch (TVS)

- (2) Disconnect vacuum hoses from TVS and connect external vacuum source to one nipple and vacuum gauge to other nipple (fig. 1J-143).

(3) Apply vacuum to TVS. Vacuum should not be indicated on gauge through TVS when air temperature is below 40° to 50°F (4.4° to 10°C). If vacuum is indicated through TVS, replace it.

(4) Start engine and warm air cleaner air above 50°F (10°C). Vacuum should be indicated on gauge through TVS when air temperature exceeds 50°F (10°C). If vacuum is not indicated on gauge through TVS, replace it.

TVS Replacement

Removal

- (1) Remove air cleaner.
- (2) Remove filter element.
- (3) Remove retaining clip(s) attaching TVS to air cleaner.
- (4) Remove vacuum hoses.

Installation

- (1) Position TVS in air cleaner.
- (2) Install retaining clip(s).
- (3) Install vacuum hoses.
- (4) Install filter element.
- (5) Install air cleaner.

EGR VACUUM DUMP VALVE

The EGR Vacuum Dump Valve is connected in parallel with the EGR vacuum source and the EGR valve for eight-cylinder engines. It functions to stop EGR operation when intake manifold vacuum drops to a level of 3 to 5 in. Hg (10 to 17 kPa), thereby effectively "dumping" the vacuum controlling EGR operation.

Vacuum Dump Valve Functional Test

WARNING: Use extreme caution when engine is operating. Do not stand in direct line with fan. Do not put hands near pulleys, belts or fan. Do not wear loose clothing

(1) Start engine and warm to normal operating temperature.

(2) Remove vacuum dump valve vacuum hose from connection at intake manifold and plug/cap manifold connection.

(3) Accelerate engine to 2000 rpm. Vacuum should be present at exhaust ports on bottom of valve. If not, replace valve.

(4) Connect vacuum dump valve vacuum hose to manifold. With engine speed at 2000 rpm, no vacuum should be present at exhaust ports on bottom of valve. If present, replace valve.

Vacuum Dump Valve Replacement

Removal

(1) Remove vacuum hoses from vacuum dump valve.

(2) Remove valve.

Installation

(1) Connect manifold vacuum hose to port "A" (fig. 1J-144).

(2) Connect EGR valve vacuum hose to port "B" (fig. 1J-144).

EGR DELAY VALVES

Forward Delay Valve

A forward delay valve is located between the EGR CTO valve and the EGR valve for certain engine applications (refer to Vacuum Diagrams for exact location). Its purpose is to modify the initial vacuum applied to the EGR valve by delaying the full effects of the vacuum. With gradual vacuum applied to the EGR valve, a harsh, sudden activation of the EGR system is avoided.

The black side of the valve is installed toward the EGR vacuum source.

Reverse Delay Valve

A reverse delay valve is located between the EGR CTO valve and the manifold vacuum source for certain engine applications (refer to Vacuum Diagrams for exact location). The purpose of the valve is to retain the manifold vacuum applied to the distributor vacuum advance mechanism when the engine is cold and is rapidly accelerated. This prevents retardation of the ignition timing. When the engine coolant temperature is heated to the calibrated temperature switching point, the CTO valve switches to ported vacuum.

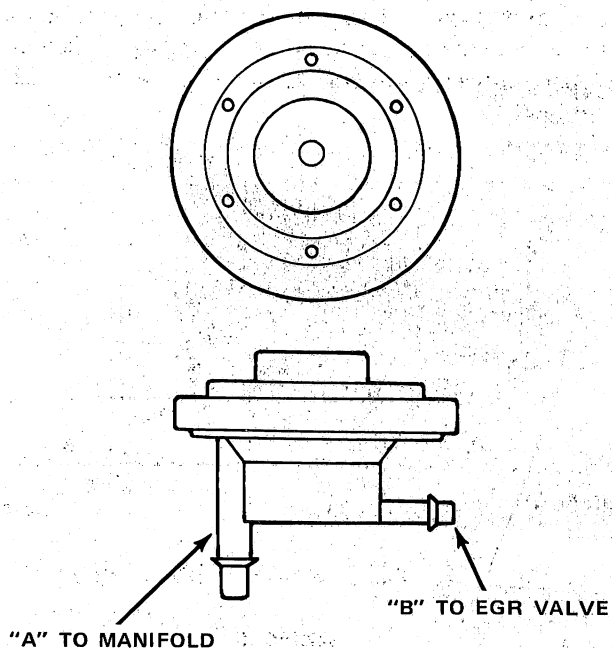

Fig. 1J-144 EGR Vacuum Dump Valve

POSITIVE CRANKCASE VENTILATION (PCV) SYSTEM

	Page
Components	1J-78
General	1J-77
Operation—PCV System	1J-78

	Page
PCV Valve Air Inlet Filter Maintenance	1J-79
PCV Valve Functional Test	1J-78

GENERAL

The PCV system functions to prevent crankcase vapor from entering the atmosphere. Filtered air is routed into the crankcase and vapor forced into the intake manifold

and burned during the engine combustion process.

In addition to controlling crankcase vapor, the system also constantly ventilates the crankcase, which helps to prevent the formation of sludge.

COMPONENTS

The PCV system is comprised of an air inlet filter, a flow-control (PCV) valve and associated hoses (figs. 1J-145, 146 and 147). The air inlet filter is located inside the air cleaner housing on four- and six-cylinder engines. It is located in the oil filler cap on eight-cylinder engines.

Positive Crankcase Ventilation (PCV) Valve

Three PCV valves with different flow rates are used. Flow rate is measured in cubic feet per minute (cfm) or liters per second (l/s). Refer to the Jeep Parts Catalog for the correct PCV valve when replacing.

Replace the PCV valve at the intervals specified in the Maintenance Schedule. Inspect all hoses in the PCV system at the same time for leaks or restrictions and clean or replace as required. PCV valve replacement may be required more often under adverse operating conditions.

OPERATION—PCV SYSTEM

Airflow through the PCV system is controlled primarily by manifold vacuum. There are two basic operating modes. When manifold vacuum is relatively high, as at idle or at cruising speed, fresh air is drawn through the air intake filter into the crankcase. After circulating through the crankcase, the vapor-filled air is forced through the PCV valve into the intake manifold. The vapor mixes with the air/fuel mixture and is burned in the combustion chambers. The PCV valve is calibrated to control airflow at a rate acceptable to the intake system.

If crankcase vapor pressure (blowby) exceeds the flow capacity of the PCV valve, airflow in the system reverses. Crankcase vapor is forced through the air cleaner element and carburetor and burned along with the air/fuel mixture.

PCV VALVE FUNCTIONAL TEST

Test the valve at idle speed for correct flow rate (cfm or l/s) providing the engine manifold vacuum is at least 14 in. Hg (45 kPa). When testing the vacuum, connect the gauge to a fitting that is as centrally located as possible on the intake manifold.

(1) Remove valve from grommet in cylinder head cover (four- and six-cylinder engines) or manifold vacuum source hose (eight-cylinder engine). Connect plastic hose of PCV Valve Tester J-23111 to valve (fig. 1J-148).

NOTE: The PCV valve must be held in a horizontal position and tapped lightly during the test. Hold the tester in a vertical position.

(2) Start engine and operate at idle speed. Observe flow rate (cfm or l/s). Refer to PCV Valve Flow Chart. With low vacuum, it may be necessary to load engine while testing flow rate.

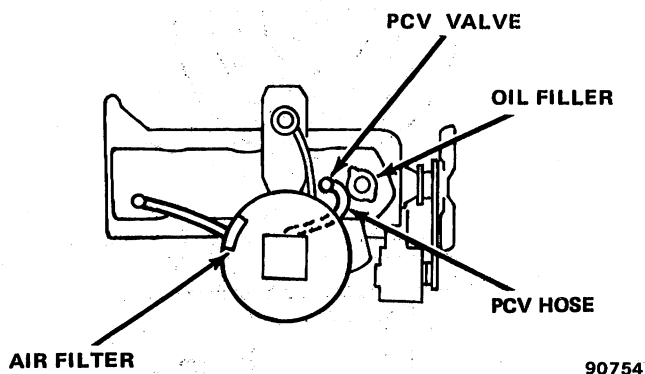

Fig. 1J-145 PCV System—Four-Cylinder Engine

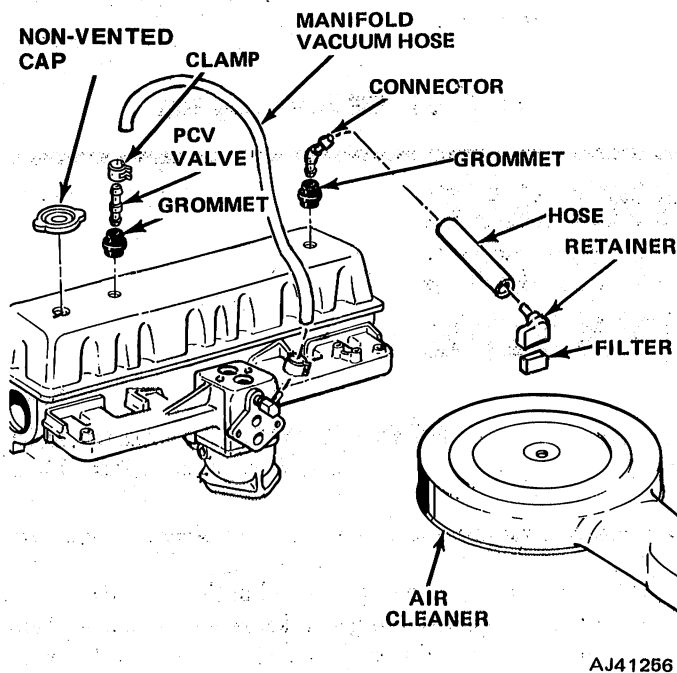

Fig. 1J-146 PCV System—Six-Cylinder Engine

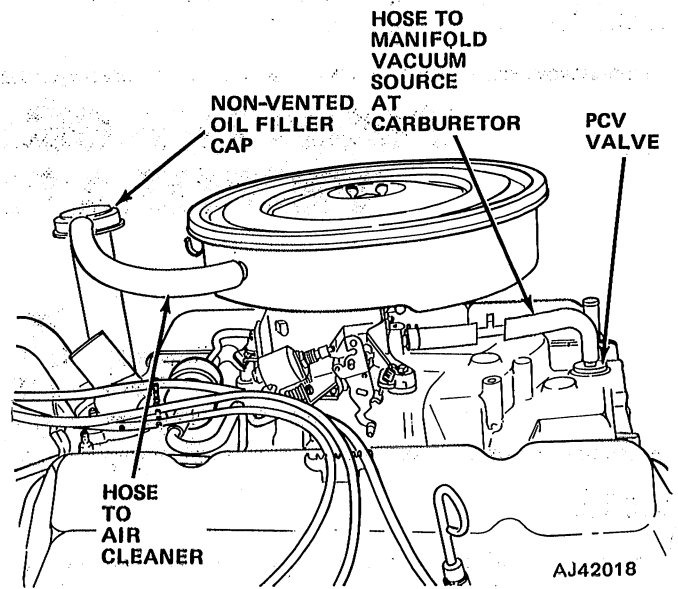

Fig. 1J-147 PCV System—Eight-Cylinder Engine

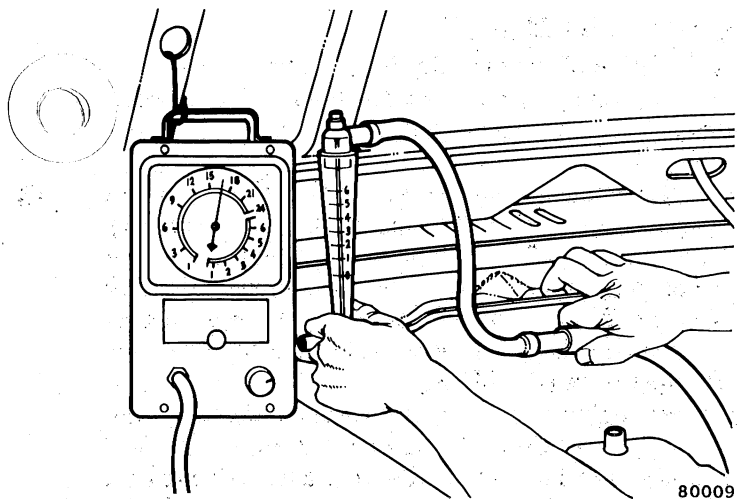

Fig. 1J-148 PCV Valve Test

(3) Replace valve having flow rate above or below specification. Ensure correct PCV valve is used for replacement.

PCV Valve Flow Rate Chart

Engine Manifold Vacuum (in. Hg.)	Air Flow CFM (liters/second)		
	Black Four-Cylinder	Yellow Six-Cylinder	Black Eight-Cylinder
15	0.5-1.0 (.236-.472)		
16			1.34-1.63 (.003-.004)
13		1.30-1.90 (.003-.005)	
6	1.05-1.85 (.496-.873)		
7			2.70-3.79 (.007-.010)
5		1.21-2.26 (.003-.006)	
3	1.5-2.5 (.708-1.18)		3.30-4.39 (.009-.012)
2		1.28-2.56 (.003-.007)	

80586

PCV VALVE AIR INLET FILTER MAINTENANCE

Perform PVC valve air inlet filter maintenance at the intervals specified in the Maintenance Schedule listed in Chapter B.

Four- and Six-Cylinder Engines

A polyester non-woven felt PCV air inlet filter is located in a filter retainer in the air cleaner.

(1) Rotate retainer to remove from air cleaner (fig. 1J-149).

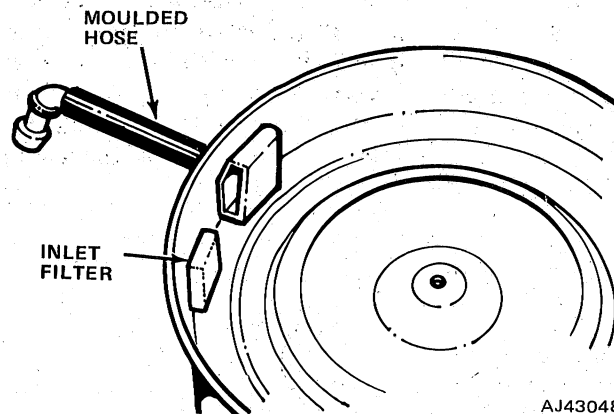

AJ43048

Fig. 1J-149 PCV Air Inlet Filter—Four- and Six-Cylinder Engines

- (2) Clean filter in kerosene.
- (3) Install filter and retainer in air cleaner.

Eight-Cylinder Engine

A polyester non-woven felt PCV air inlet filter is located in the sealed oil filler cap.

- (1) Remove oil filler cap from engine.
- (2) To clean, apply light air pressure in reverse direction of normal flow (through filler tube opening of cap).
- (3) Install oil filler cap and connect hose from air cleaner to oil filler cap.

NOTE: Replace the filler cap if filter is deteriorated.

THERMOSTATICALLY CONTROLLED AIR CLEANER (TAC) SYSTEM

	Page
Air Cleaner Trap Door	1J-82
General	1J-79
Operation—TAC System	1J-80

	Page
Testing—TAC System	1J-81
Thermal Sensor	1J-82

GENERAL

The Thermostatically Controlled Air Cleaner (TAC) System provides heated air for the carburetor during

engine warm-up when the outside (ambient) air temperature is low. Warm intake air permits the carburetor to have a leaner air/fuel mixture, reducing hydrocarbon

emissions. It also improves engine performance during warm-up and minimizes carburetor icing.

All Jeep vehicles are equipped with a vacuum-operated TAC system. In addition, vehicles with six-cylinder engines have air cleaners with trap doors that close off the air cleaner air intake duct when the engine is turned off. This prevents fuel vapor, etc., from escaping to the atmosphere during the time the engine is inoperative.

The TAC system is comprised of a heat stove that is either fully encloses the exhaust manifold (four-cylinder engines) or partially encloses the exhaust manifold (six- and eight-cylinder engines), a heated air tube, an air cleaner assembly equipped with a thermal sensor, and a vacuum motor and air valve assembly (figs. 1J-150 and 151). The air cleaner duct is attached by a flexible duct to the ambient air inlet at the front of the engine compartment.

OPERATION—TAC SYSTEM

The position of the air valve is controlled by manifold vacuum opposing spring tension. Manifold vacuum is controlled by a thermal sensor located in the air cleaner housing.

The sensor incorporates a vent valve that regulates the vacuum applied to the vacuum motor and thereby controls the air valve position. The air supply is either all heated air, a mixture of heated and ambient air or all ambient air from outside the vehicle. The result is that the inlet air to the carburetor is maintained at the correct temperature (fig. 1J-152).

During engine warm-up, the thermal sensor passes vacuum to the TAC vacuum motor. The air valve is held in the heat On position. Exhaust manifold-heated air flows to the air cleaner. As the temperature of the incoming air approaches the calibrated temperature, the

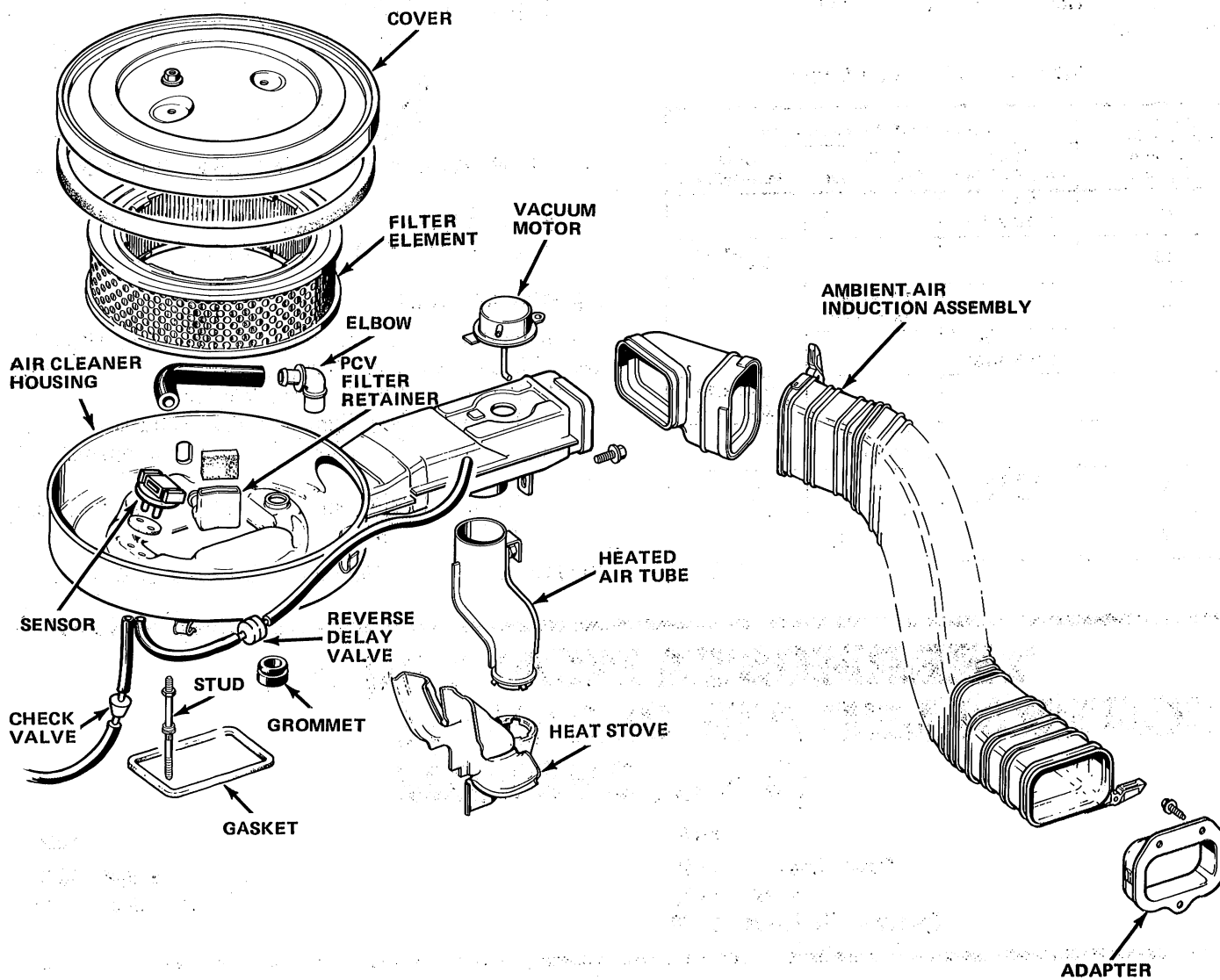

90644B

Fig. 1J-150 TAC System—Four-Cylinder Engine

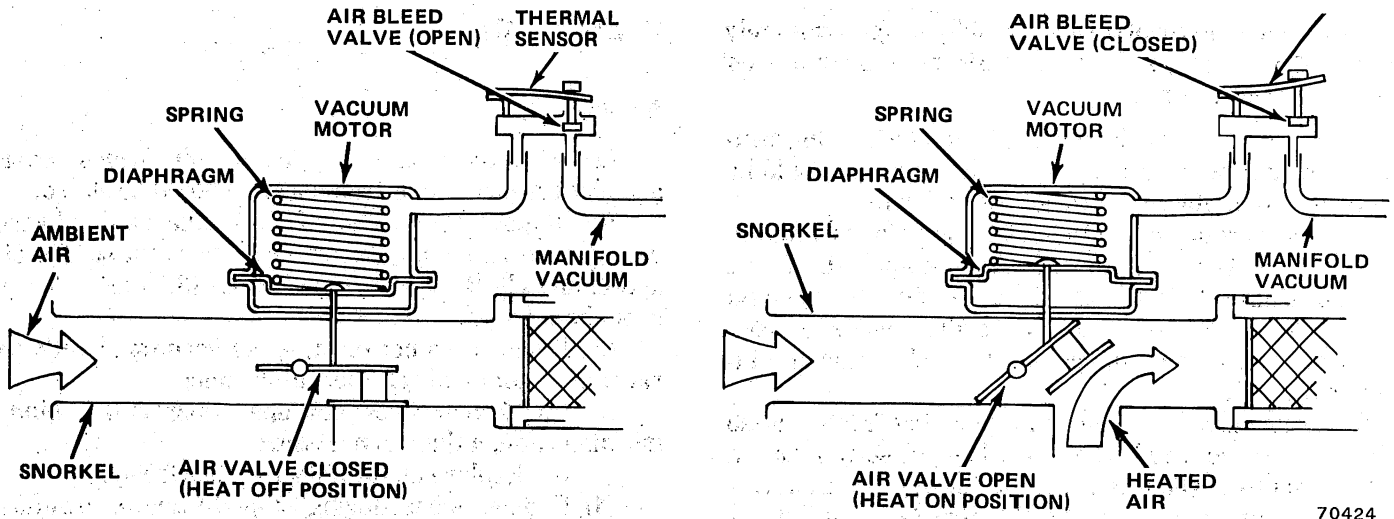

Fig. 1J-151 TAC System—Typical—Six- and Eight-Cylinder Engines

70424

thermal sensor opens the vacuum to the atmosphere. This allows spring pressure to force the valve to the heat **Off** position. In this position, air flows from outside the vehicle, through the ambient air duct, to the air cleaner.

During hard acceleration, manifold vacuum drops. This causes the air valve to move to the heat **Off** position, regardless of air temperature, to provide maximum airflow.

TESTING—TAC SYSTEM

(1) Remove air cleaner assembly from carburetor and allow to cool to room temperature.

(2) After cooling, sight through air cleaner duct to observe position of air valve. It should be fully open to outside ambient air (heat **Off** position).

(3) Install air cleaner assembly on carburetor and connect heated air tube and manifold vacuum hose.

WARNING: Use extreme caution when engine is operating. Do not stand in direct line with fan. Do not put hands near pulleys, belts or fan. Do not wear loose clothing.

(4) Start engine and observe position of air valve. It should be fully closed to outside (ambient) air (heat **On** position).

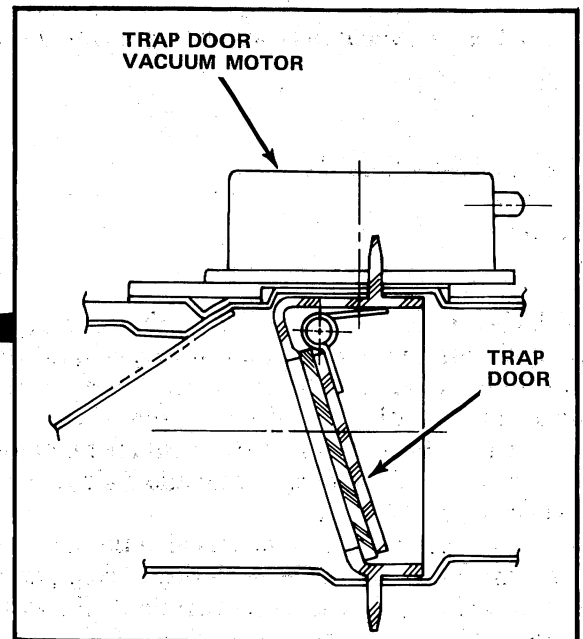
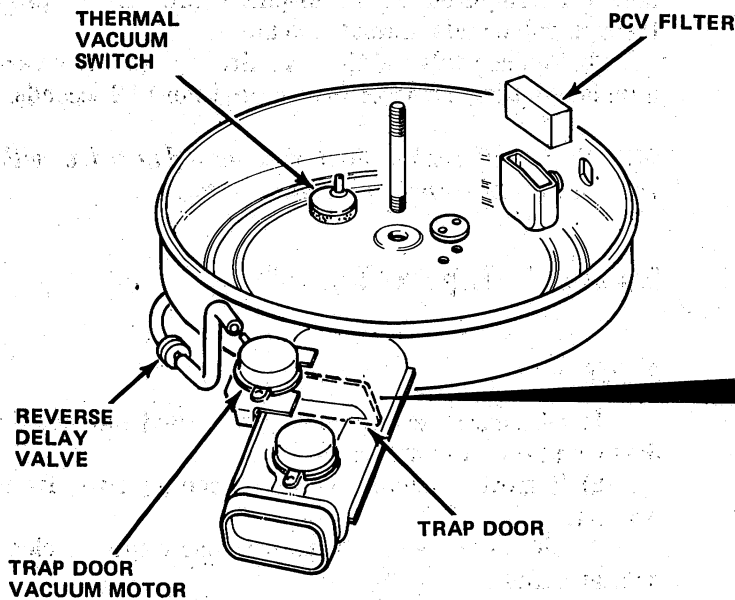

90569

Fig. 1J-152 Air Cleaner with Trap Door

(5) Move the throttle lever rapidly to approximately 1/2 to 3/4 opening and release. Air valve should open and then close again.

(6) Allow engine to warm to normal operating temperature and observe position of air valve. It should be fully open to ambient air (heat **Off** position).

If valve does not move to heat **On** position at temperatures below 83°F (28°C) with vacuum applied, inspect for a mechanical bind in the duct, disconnected vacuum motor linkage or air leaks in vacuum hoses at connections on the vacuum motor, thermal sensor and intake manifold.

If the air valve mechanism is operating freely and no air leaks are detected, connect a hose directly from an intake manifold vacuum source to the vacuum motor.

If the valve now moves to the heat **On** position, replace thermal sensor.

If the valve remains in the heat **Off** position, replace the vacuum motor assembly.

THERMAL SENSOR

Replacement

(1) Remove air cleaner and disconnect vacuum hoses from sensor.

(2) Break vacuum nipples off sensor. Remove sensor and gasket from air cleaner.

(3) Install replacement sensor and gasket. Press retainers over vacuum nipples.

(4) Connect vacuum hoses and install air cleaner.

AIR CLEANER TRAP DOOR

Operation

Vehicles with six- and eight-cylinder engines are equipped with air cleaners that have spring-loaded trap doors to close-off the air cleaner/carburetor when the engine is inoperative. The door is actuated by a vacuum motor; when the engine is started, intake manifold vacuum causes the door to open and allow air to enter the air cleaner (fig. 1J-152).

A reverse delay valve is connected in the vacuum hose to prevent the trap door from closing during low engine vacuum periods (i.e., engine acceleration). The valve also functions to prevent abrupt closings of the trap door when the engine is turned off by gradually allowing atmospheric pressure to enter the vacuum motor. A check valve is also connected in the vacuum hose.

Functional Tests

Trap Door

(1) With the engine off, remove air cleaner cover and observe position of trap door. It should be closed.

(2) Remove vacuum hose from intake manifold vacuum source and apply an external vacuum source of approximately 2 to 4 in. Hg (6.75 to 13.50 kPa). Trap door should open.

(3) If door does not open, apply vacuum directly to vacuum motor on air cleaner intake duct.

(a) If door does not open, inspect for binding/distortion, adjust as necessary.

(b) Replace motor if door swings freely.

(4) If door opens during step (3) above, examine vacuum hose for obstruction, cracks and kinks. Correct as necessary and retest as outlined in step (2) above.

(5) If vacuum hose is not defective, remove reverse delay valve, join vacuum hose and retest as outlined in step (2) above. If door opens, replace reverse delay valve.

Reverse Delay Valve

The reverse delay valve provides approximately 9 seconds delay before allowing the trap door to completely close. Test valve according to the following procedure.

(1) Remove vacuum hose from red end of valve and apply an external vacuum source of approximately 2 to 4 in. Hg (6.75 to 13.50 kPa).

(2) With elapsed time indicator available in view, note time required for atmospheric pressure to pass through valve and eliminate vacuum.

(3) Replace valve if time required to eliminate vacuum is less than 4.5 seconds or more than 13.2 seconds.

NOTE: Install replacement reverse delay valve with red end toward trap door vacuum motor.

Replacement—Trap Door Vacuum Motor

Removal

(1) Disconnect vacuum hoses, heated and ambient air ducts, and remove air cleaner.

(2) Remove vacuum motor attaching rivet from bracket.

(3) Lift motor away from bracket, rotate to clear door arm and remove.

Installation

(1) Rotate motor to clear door arm and lower into bracket.

(2) Secure motor to bracket with rivet.

(3) Install air cleaner, air ducts and vacuum hoses.

FEEDBACK SYSTEMS

	Page		Page
Component Replacement	1J-87	Diagnostic Procedures For CEC System	1J-111
Computerized Emission Control (CEC) System (Six-Cylinder Engine)	1J-84	Diagnostic Procedures For C4 System General	1J-83 1J-88
C4 System (Four-Cylinder Engine)	1J-83	System Operation	1J-85

GENERAL

Two different feedback systems are used with Jeep vehicles, one for four-cylinder engines and one for six-cylinder engines. Each system is designed to achieve the same objective: reduce undesirable exhaust emissions, in conjunction with either a three-way catalytic (TWC) converter or dual bed (TWC and COC) converter, while maintaining fuel economy and good engine performance.

With both systems, the primary feedback data is provided by an oxygen sensor located in the exhaust system. This sensor provides a voltage that is proportional to the amount of oxygen present in the exhaust gas. This data is used by each system microprocessor to regulate and optimize the air/fuel mixture.

The C-4 system incorporates a self-diagnostic feature that enables service personnel to localize system malfunctions.

C4 SYSTEM (FOUR-CYLINDER ENGINE)

This system is used with four-cylinder engines installed in CJ vehicles manufactured for sale in California.

NOTE: All reference to CJ vehicles also pertains to Scrambler vehicles.

Electronic Control Module (ECM)

The ECM (microprocessor) is the "brains" of the C4 System. It is programmed to determine the correct air/fuel mixture necessary for each engine operating mode. This is accomplished via the several data inputs and the standard data stored in the read-only-memory (ROM) circuit.

The ECM also contains a Programmable Read Only Memory (PROM) circuit (calibration unit) that has stored data unique to the vehicle.

CAUTION: To ensure the internal components and connectors do not get wet when the passenger compartment is washed, it is advisable not spray water directly on the ECM housing because it is not completely waterproof.

Oxygen Sensor

This component of the system provides a variable voltage (100 to 900 mv) for the microprocessor (ECM)

that is actually a voltage analog for the oxygen content in the exhaust gas. As the oxygen content increases (lean mixture), the voltage output from the sensor decreases proportionally and as the oxygen content decreases (rich mixture), the voltage output increases proportionally. The microprocessor uses the voltage data to control the mixture control (MC) solenoid in the model E2SE carburetor and maintain an optimum air/fuel mixture.

NOTE: The engine must be warmed to a predetermined temperature before the oxygen sensor voltage output is accepted by the microprocessor.

NOTE: The oxygen sensor must be replaced after 30,000 miles (48 000 km) of engine operation. The **Emission Maintenance** lamp will be illuminated to indicate the necessity for replacement. Refer to Chapter 1L—Engine Instrumentation for additional information.

C4 System Data Senders

In addition to the oxygen sensor, the following data senders are used to provide the microprocessor with engine operation data.

- Adaptive Vacuum Switch—Closed during engine idle and partial throttle engine operation (Adaptive Mode of Operation).

NOTE: In the Adaptive Mode, the mixture control (MC) solenoid is regulated to produce predetermined air/fuel mixture ratios. During acceleration from idle to partial throttle and deceleration from partial throttle to idle the oxygen sensor cannot react fast enough to the changes in the air/fuel mixture. As a consequence, high HC and CO exhaust gases would be emitted momentarily unless the system switched to predetermined (programmed) air/fuel mixture ratios.

- Wide Open Throttle (WOT) Vacuum Switch—When a wide open throttle condition occurs, the decreased manifold vacuum (at 5 in. Hg, 17 kPa) closes the WOT switch, which results in the mixture control (MC) solenoid being regulated to provide the rich air/fuel mixture necessary for the increased airflow (WOT Mode of Operation).
- Engine rpm (tach) Voltage from Distributor—The mixture control (MC) solenoid is deenergized until the voltage is equivalent to 200 rpm. The result is a rich air/fuel mixture for engine starting (Inhibit or Starting Mode of Operation).

- **Coolant Temperature Sensor**—During engine warm-up, below 150°F (66°C), the electrical impedance of the coolant temperature sensor is high. The result is the ECM (microprocessor) does not accept the oxygen sensor voltage output and a fixed air/fuel mixture is maintained (Open Loop Mode of Operation).

In addition to the above data input to the ECM, the ECM also determines the temperature of the oxygen sensor from its electrical impedance. Until the oxygen sensor is heated to a temperature of 600°F (320°C), a fixed air/fuel mixture is maintained (Open Loop Mode of Operation).

Mixture Control (MC) Solenoid

The MC solenoid is an electro-mechanical device integral with the model E2SE carburetor that regulates the air/fuel mixture according to "commands" from the ECM.

One terminal of the MC solenoid is connected to 12v (battery voltage) and the other is connected to the ECM. The ECM functions as a switch that provides either a ground for current flow to energize the MC solenoid or an open circuit to deenergize the MC solenoid. The ECM switches the MC solenoid **ON** and **OFF** ten times a second.

When the MC solenoid is energized the needle is inserted into the jet and the result is a lean air/fuel mixture. When the solenoid is deenergized the needle is withdrawn from the jet and the result is a rich air/fuel mixture.

The average or effective air/fuel mixture is determined by the length of time the solenoid is either energized or deenergized (period of dwell) during each **ON—OFF** cycle (fig. 1J-153).

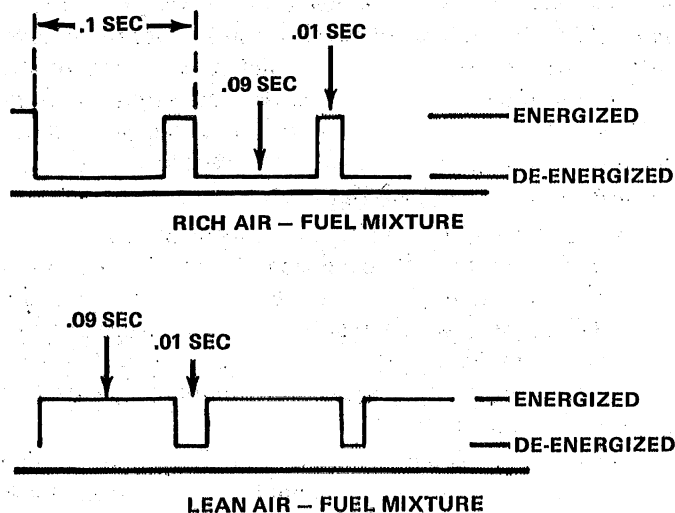

Fig. 1J-153 MC Solenoid ON—OFF Cycle

C4 System Malfunction Test Bulb

The C4 System has provision for connecting a test bulb that will inform a technician of the need for service. If a malfunction exists, the bulb will illuminate. The ECM also incorporates a diagnostic program that will flash a trouble code that identifies the malfunction when this function is activated.

Three-Way Catalytic (TWC) Converter

The TWC converter functions three ways to convert:

- HC to water vapor and carbon dioxide (CO₂).
- CO to carbon dioxide (CO₂) and oxygen.
- NO_x and CO to nitrogen (N₂) and carbon dioxide (CO₂).

Refer to Exhaust Systems—Chapter 1K for service information.

COMPUTERIZED EMISSION CONTROL (CEC) SYSTEM (SIX-CYLINDER ENGINE)

This system is used with all six-cylinder engines installed in CJ vehicles manufactured for sale in California and all six-cylinder engines installed in Cherokee, Wagoneer and Truck vehicles to control the carburetor air/fuel mixture and the air injection system (i.e., switching air either upstream or downstream).

Micro Computer Unit (MCU)

The MCU is a microprocessor that monitors the oxygen sensor voltage and, based upon the mode of operation, generates an output control signal for the model BBD carburetor stepper motor.

If the system is in the closed loop mode of operation, the air/fuel mixture will vary according to the oxygen content in the exhaust gas and current engine operation.

If the system is in the open loop mode of operation, the air/fuel mixture will be based on a predetermined ratio that is dependent on several engine operating parameters.

Oxygen Sensor

This component of the system provides a variable analog voltage (millivolts) for the microprocessor (MCU) that is proportional to the oxygen content in the exhaust gas.

NOTE: A "lean" air/fuel mixture causes the exhaust gas to have a greater oxygen content. A "rich" air/fuel mixture causes the exhaust gas to have less oxygen content. The optimum air/fuel ratio is 14.7:1.

Data Senders

In addition to the oxygen sensor, the following data senders are used to provide the microprocessor (MCU) with engine operation data.

Two vacuum (4 in. Hg and 10 in. Hg) operated electric switches, one mechanically operated electric switch, one engine coolant operated switch (dual function) and one air temperature operated switch are used to detect and send engine operating data to the MCU. They detect the following engine operating conditions.

- Cold Engine Start-up and operation
- Wide open throttle (WOT)
- Idle (closed throttle)
- Partial and deep throttle

Components

- **Thermal Electric Switch (TES)**—The TES is attached to the inside of the air cleaner to provide either a ground circuit for the microprocessor to indicate the necessity for a cold weather engine start-up (when the air temperature is below the calibrated value) or an open circuit to indicate normal engine start-up (when the air temperature is above the calibrated temperature).
- **Coolant Temperature Switch**—This dual function switch is controlled by the engine coolant temperature and is integral with the intake manifold heater control switch. When open, the switch indicates the engine is cold (i.e., temperature less than 160°F or 71°C).
- **4 in. Hg Vacuum Switch**—This switch is controlled by carburetor ported vacuum and has a normally closed (NC) electrical contact that indicates a closed throttle condition. The switch is opened by 4 in. Hg (13 kPa) vacuum level.
- **10 in. Hg Vacuum Switch**—This switch is controlled by manifold vacuum. When open, the switch indicates a deep throttle condition (i.e., non-cruise engine operating condition).
- **Wide Open Throttle (WOT) Switch**—This mechanically operated electrical switch (located at the base of the carburetor) is controlled by throttle position to indicate a wide open throttle condition.

NOTE: For the system to operate properly, *all* associated components and related systems must be intact and operational. This includes EGR valves, EGR related componentry, correct ignition advance vacuum hose routing, etc.

Engine RPM (Tach) Voltage

This voltage is supplied from the "tach" terminal on the distributor. Until a voltage equivalent to a pre-determined rpm is received by the MCU, the system remains in the Open Loop Mode of Operation. The result is a fixed rich air/fuel mixture for engine starting purposes.

Stepper Motor

The Stepper Motor is integral with the model BBD carburetor. It controls the metering pins that vary the

size of the idle and main air inlet orifices located in the carburetor body. The motor moves the pins in and out of the orifices in steps according to the control signal generated by the MCU. The motor has a range of 100 steps, but the normal operating area is mid-range (e.g., 40 to 60 steps).

When the metering pins are stepped in the direction of the orifices, the air/fuel mixture becomes richer; when stepped away from the orifices, the mixture becomes leaner.

Dual Bed (TWC and COC) Catalytic Converter

This type converter has "downstream" air injection. Whether air is injected "upstream" (i.e., directly into the exhaust manifold) or "downstream" (i.e., into the converter) is a function of the MCU (microprocessor).

Refer to Exhaust Systems—Chapter 1K for service information concerning the dual bed (TWC and COC) converter.

SYSTEM OPERATION

There are two primary modes of operation for both the C4 and CEC Systems:

- open loop
- closed loop

Open Loop Mode of Operation

In general terms, each system will be in the open loop mode of operation (or a variation of) whenever the engine operating conditions do not conform with the programmed criteria for closed loop operation.

During open loop operation the air/fuel mixture is maintained at a programmed ratio that is dependent on the type of engine operation involved. The oxygen sensor data is not accepted by either system microprocessor during this mode of operation. The following conditions involve open loop operation (fig. 1J-154).

- Engine Start-Up
- Coolant or Air Temperature Too Low
- Oxygen Sensor Temperature Too Low
- Engine at Idle Speed
- Wide Open Throttle (WOT)
- Battery Voltage Too Low

Closed Loop Mode of Operation

When all input data conforms with the programmed criteria for closed loop operation, the oxygen content output voltage from the oxygen sensor is accepted by the microprocessor. This results in an air/fuel mixture that will be optimum for the current engine operating condition and also will correct any pre-existing too "lean" or too "rich" mixture condition (fig. 1J-154).

NOTE: A high oxygen content in the exhaust gas indicates a "lean" air/fuel mixture. A low oxygen content indicates a "rich" air/fuel mixture. The optimum air/fuel mixture ratio is 14.7:1.

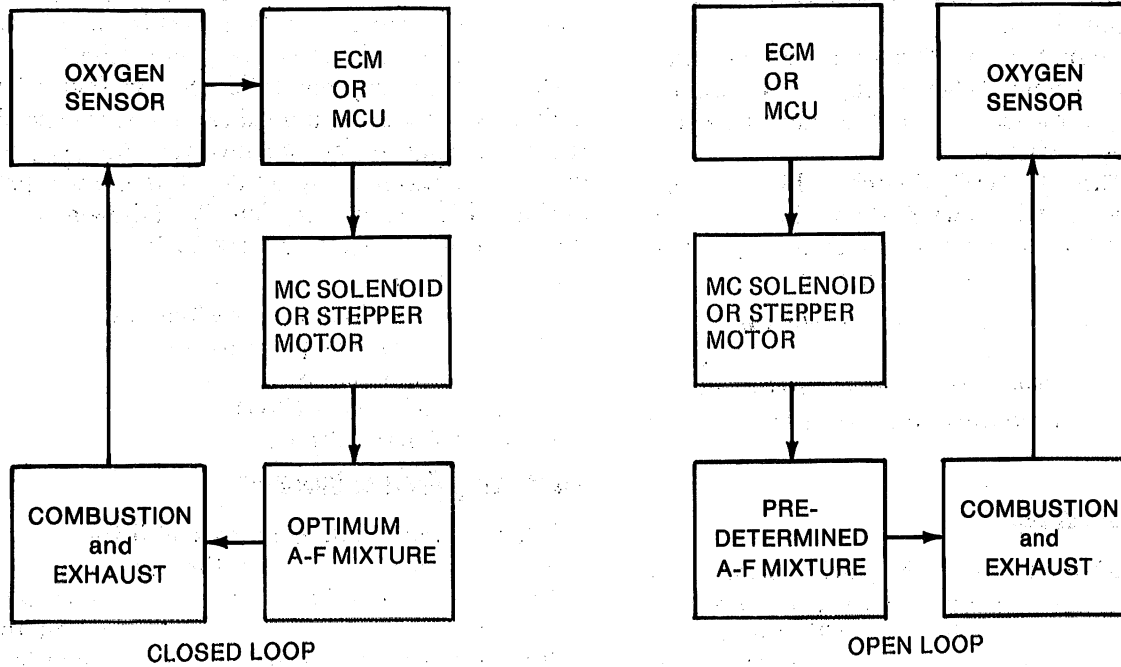
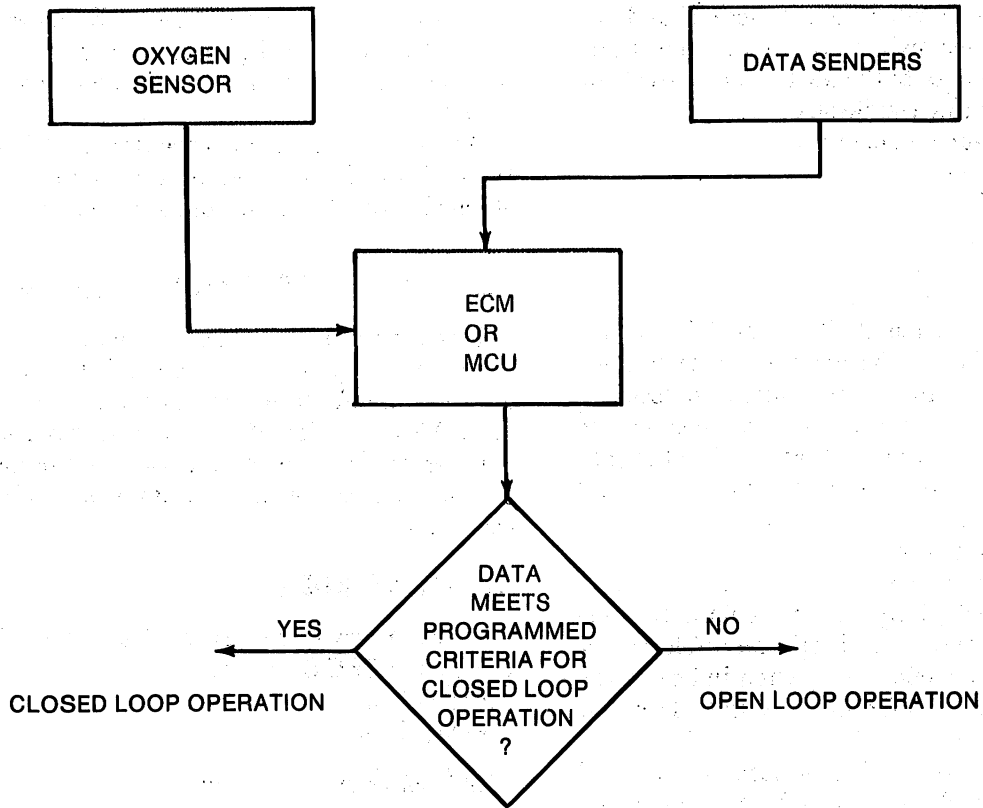

90768

Fig. 1J-154 . Open and Closed Loop Modes of Operation

COMPONENT REPLACEMENT

Oxygen Sensor

- (1) Disconnect wire connector.
- (2) Remove sensor from exhaust manifold.

NOTE: Use Tool J-29533 to remove oxygen sensors from four-cylinder engines.

- (3) Clean threads in manifold.
- (4) Coat replacement sensor threads with antiseize compound.

- (5) Install sensor.

(a) Four-cylinder engine: using Tool J-29533, tighten sensor with 20 to 25 foot-pounds (27 to 34 N•m) torque.

(b) Six-cylinder engine: tighten sensor with 31 foot-pounds (42 N•m) torque.

CAUTION: Ensure that wire terminal ends are properly seated in connector prior to connecting connector.

- (6) Connect wire connector.

NOTE: Do not push rubber boot down on sensor body beyond 1/2 inch above base.

NOTE: Oxygen Sensor pigtail wires cannot be spliced or soldered. If broken, replace sensor.

Vacuum Switches

- (1) Identify and tag vacuum hoses, and disconnect from switches.
- (2) Disconnect wire harness connector(s).

NOTE: The six-cylinder engine (CEC) system has one connector and the four-cylinder engine (C4) system has two connectors.

- (3) Remove vacuum switch and bracket assembly from right inside fender panel.

NOTE: The vacuum switches are not serviced individually. The complete assembly must be replaced as a unit.

- (4) Install replacement vacuum switch and bracket assembly.
- (5) Connect wire harness connector(s).
- (6) Connect vacuum hoses.

ECM—MCU

The C4 system microprocessor (CJ vehicles only) is located in the passenger compartment on the left-hand kick panel (fig. 1J-155). The six-cylinder engine microprocessor is located in the engine compartment on the left-hand inner fender panel.

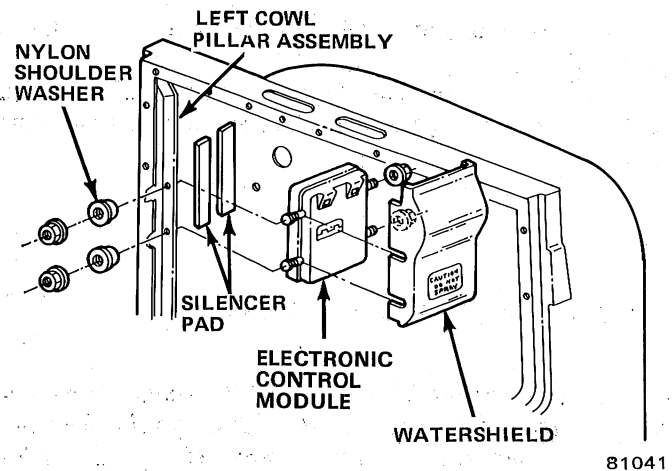

Fig. 1J-155 ECM Installation—CJ Vehicles

- (1) Remove microprocessor.
 - (a) Remove ECM from mounting bracket.
 - (b) Remove MCU attaching bolts.
- (2) Disconnect wire harness connector.

CAUTION: Ensure that the connector terminals are not forced out of position or bent when connecting connector.

- (3) Connect wire harness connector to replacement unit.
- (4) Install replacement unit.
 - (a) Install ECM in mounting bracket.

CAUTION: ECM bracket is insulated from chassis ground. Do not ground bracket!

- (b) Install MCU with attaching bolts.

Mixture Control (MC) Solenoid (Model E2SE Carburetor)

- (1) Remove air cleaner.
- (2) Disconnect solenoid wire connector.
- (3) Remove retaining screws.
- (4) Remove unit from carburetor.
- (5) Coat rubber seal (on end of stem) on replacement solenoid with silicone grease or light engine oil.

CAUTION: Solenoid stem must be accurately aligned in recess at bottom of bowl.

- (6) Using new gasket, install replacement MC solenoid in carburetor.
- (7) Connect solenoid wire connector.
- (8) Install air cleaner.

Stepper Motor (Model BBD Carburetor)

- (1) Remove air cleaner.
- (2) Disconnect motor wire connector.

CAUTION: Avoid dropping metering pins and spring when removing motor.

(3) Remove retaining screw and unit from carburetor.

(4) Install replacement motor on carburetor with retaining screw. Tighten with 25 inch-pounds (2.8 N•m) torque.

(5) Connect wire connector.

(6) Install air cleaner.

Coolant Temperature Switch (or Sensor)

NOTE: For six-cylinder engines, the coolant temperature switch is integral with the intake manifold heater coolant temperature control switch. The switch is located at the rear of the intake manifold. For four-cylinder engines, the sensor is located at the left rear of the cylinder block.

(1) Disconnect wire connector.

(2) Remove switch.

(3) Install replacement switch. Tighten with 72 inch-pounds (7 N•m) torque.

(4) Connect wire connector.

DIAGNOSTIC PROCEDURES FOR C4 SYSTEM

The C4 System should be considered as a possible source of trouble for engine performance, fuel economy and exhaust emission complaints only after normal tests and inspections that would apply to a vehicle without the C4 system have been performed. An integral self-diagnostic subsystem within the ECM detects the problems that are most likely to occur.

The diagnostic system will illuminate a test bulb if a fault exists. If the trouble code test pigtail wire is manually connected to ground (located under the dash), the system will flash a trouble code if a fault has been detected.

As a routine system test, the test bulb will also be illuminated when the ignition switch is first turned on and the engine not started. If the test lead is grounded, the system will flash a trouble code 12, which indicates that the diagnostic system is functioning normal (i.e., no engine rpm voltage to the ECM). This consists of **one flash** followed by a pause and then **two flashes**. After a longer pause, the code will be repeated two more times. The cycle will repeat itself until the engine is either started or the ignition switch turned off. When the engine is started, the bulb will remain illuminated for a few seconds.

If the test lead is grounded with the engine operating and a fault has been detected by the system, the trouble code will be flashed three times. If more than one fault has been detected, the second trouble code will be flashed three times after the first code is flashed. The series of code flashes will then be repeated.

A trouble code indicates a problem within a specific circuit, for example, code 14 indicates a problem in the coolant temperature sensor circuit. This includes the coolant temperature sensor, wire harness, and electronic control module (ECM). The procedure for determining which of the three is at fault is located in the Trouble Code 14 chart. For other trouble codes, refer to the applicable charts.

Because the self-diagnostic subsystem does not detect all possible faults, the absence of a flashed code does not always indicate that there is no problem with the system. To determine this, a system operational test is necessary. This test should be performed when the test bulb does not flash a trouble code but the C4 System is suspected because no other reason can be determined for a specific complaint. In addition to the test bulb, a dwell meter, test lamp, digital volt-ohmmeter, tachometer, vacuum gauge and jumper wires are required to diagnose system problems. A test lamp rather than a voltmeter should be used when so instructed. **Although most dwell meters should be acceptable, if one causes a change in engine operation when it is connected to the mixture control (MC) solenoid dwell pigtail wire connector, it should not be used.** The following models of older Sun tach/dwell units should not be used: G, GA, TDT1, 2, 5, 216 and 216-1.

The dwell meter, set for the six-cylinder engine scale and connected to a pigtail wire connector from the mixture control (MC) solenoid in the carburetor, is used to determine the air/fuel mixture dwell. When the dwell meter is connected, do not allow the terminal to contact any engine component that is connected to engine ground. This includes hoses because they may be electrically conductive. With a normally operating engine, the dwell at both idle speed and partial throttle will be between 10 degrees and 50 degrees and will be varying. Varying means the pointer continually moves back and forth across the scale. The amount it varies is not important, only the fact that it does vary. This indicates closed loop operation, meaning the mixture is being varied according to the input voltage to the ECM from the oxygen sensor. With wide open throttle (WOT) or cold engine operation, the air/fuel mixture ratio will be fixed and the pointer will not vary. This is open loop operation, meaning the oxygen sensor output has no effect on the air/fuel mixture. If there is a question whether or not the system is in closed loop operation, richening or leaning the mixture will cause the dwell to vary if the system is in closed loop operation.

NOTE: Normally, system tests should be performed with the engine warm (upper radiator hose hot).

Trouble Code Memory

When a fault is detected in the system, the test bulb will be illuminated and a trouble code will be set in the

memory of the ECM. However, if the fault is intermittent, the test bulb will be extinguished when the fault no longer exists, but the trouble code will remain in the ECM memory.

Long Term Memory

The ECM (for CJ vehicles) has long term memory. With this provision, trouble codes are not lost when the ignition switch is turned off. Certain troubles may not appear until the engine has been operated 5 to 18 minutes at partial throttle. For this reason, and for intermittent troubles, a long term memory is desirable. To clear the long term memory, disconnect and connect the battery negative cable.

NOTE: *Long term memory causes approximately a 13 ma battery drain with the ignition switch off.*

Trouble Codes

The test bulb will only be illuminated under the conditions listed below when a malfunction exists. When the malfunction is eliminated, the bulb will be extinguished and the trouble code will be reset, except for one fault, code 12. If the bulb is illuminated intermittently, but no trouble code is flashed, refer to this symptom within Driver Complaints.

- Trouble Code 12—No rpm (tach) voltage to the ECM.
- Trouble Code 13—Oxygen sensor circuit. The engine has to operate for approximately five minutes at partial throttle before this code will be flashed.
- Trouble Code 14—Shorted coolant temperature sensor circuit. The engine has to operate two minutes before this code will be flashed.
- Trouble Code 15—Open coolant temperature sensor circuit. The engine has to operate for approximately five minutes at partial throttle before this code will be flashed.
- Trouble Codes 21 and 22 (at same time)—Grounded WOT switch circuit.
- Trouble Code 22—Grounded adaptive vacuum or WOT switch circuit.
- Trouble Code 23—Open or grounded carburetor MC solenoid circuit.
- Trouble Code 44—Voltage input to ECM from oxygen sensor indicates continuous "lean" mixture. MC solenoid is regulated to produce continuous "rich" mixture. The engine has to operate approximately five minutes at partial throttle with a torque load

and the C4 System in closed loop operation before this code will be flashed.

- Trouble Codes 44 and 45 (at same time)—Faulty oxygen sensor.
- Trouble Code 45—Voltage input to ECM from oxygen sensor indicates continuous "rich" mixture. MC solenoid is regulated to produce continuous "lean" mixture. The engine has to operate approximately five minutes at partial throttle with a torque load and the C4 System in closed loop operation before this code will be flashed.
- Trouble Code 51—Faulty calibration unit (PROM) or installation.
- Trouble Codes 52 and 53—Test bulb off, intermittent ECM problem. Test bulb on, faulty ECM.
- Trouble Code 54—Faulty MC Solenoid and/or ECM.
- Trouble Code 55—Faulty oxygen sensor circuit or ECM.

When the test bulb is not illuminated with the engine operating, but a trouble code can be obtained, the situation must be evaluated to determine if the fault is intermittent or because of engine operating conditions.

For all troubles, except codes 13, 44, and 45, the test bulb should be illuminated with the engine speed below 800 rpm after five minutes of operation.

If codes other than 13, 44, and 45 can be obtained with the test bulb off, the diagnostic charts cannot be used because the system is operating normally. All that can be performed is a physical inspection of the circuit indicated by the trouble code. It should be inspected for poor wire connections, frayed wires, etc., then the System Operational Test should be performed.

Faults 13, 44, and 45 require engine operation at partial throttle with an engine load for an extended period of time before a code will be flashed. Trouble code 15 requires five minutes of operation before it will be flashed. The diagnostic chart should be used if these codes are obtained even though the test bulb is not illuminated at idle.

Calibration Unit (PROM)

The microprocessor has a calibration unit called a PROM that is programmed with specific instructions pertaining to the engine. It is not a replaceable assembly.

Trouble code 51 indicates the PROM has been installed improperly or is defective. When code 51 is flashed, the ECM (microprocessor) should be replaced (fig. 1J-156).

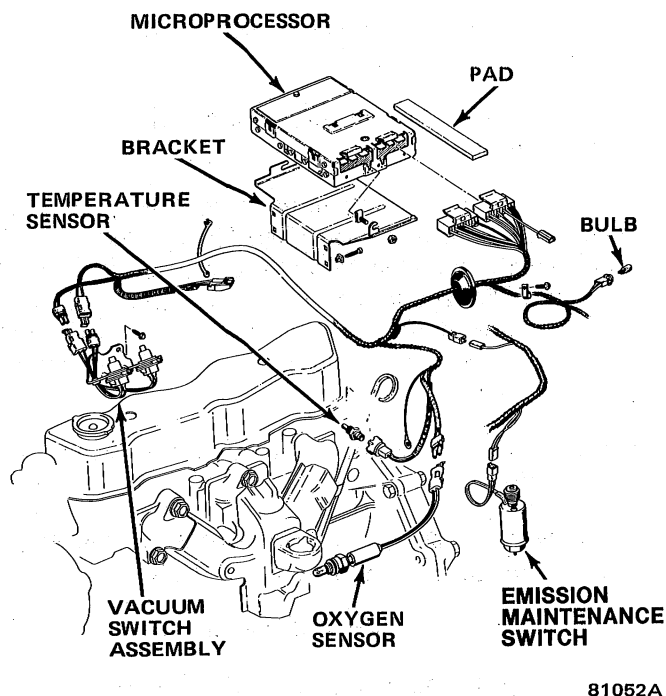

Fig. 1J-156 C4 System

CAUTION: If trouble code 51 was caused by the PROM (Calibration Unit) being installed backwards, replace ECM with another unit. Whenever the Calibration Unit is installed backwards and the ignition switch is turned on, the unit is destroyed.

Carburetor Model E2SE Idle Mixture Adjustment

The idle mixture is calibrated during factory assembly and should normally not need adjustment in the field. However, if necessary because of results of C4 System diagnosis, contamination, overhaul, replacement of parts, etc., it can be adjusted according to the procedure outlined below. Because the C4 System is very complex, the procedure must be followed precisely.

The dwell indication from the MC Solenoid is used for the adjustment. During engine idle, it is normal for the dwell to increase and decrease fairly consistently over a relatively narrow range, such as 5 degrees. However, it may occasionally vary by as much as 10 degrees to 15 degrees momentarily because of temporary abrupt mixture changes. The dwell specified in the procedure is the average for the most consistent variation.

The engine must be allowed to stabilize at idle or 800 rpm, as applicable, before the dwell is acceptable as a reference for adjustment.

NOTE: The mixture control solenoid dwell is an indication of the ratio of "on" to "off" time (i.e., solenoid energized time-to-deenergized time ratio).

(1) If idle mixture plug has not been removed, remove according to following procedure.

(a) Remove air cleaner and gasket.

WARNING: Battery negative cable must be removed to prevent a potential fire hazard when fuel pipe is disconnected.

(b) Disconnect battery negative cable.

(c) Disconnect fuel pipe and vacuum hoses from carburetor. Identify and tag hoses.

(d) Disconnect throttle linkage and electrical connectors.

(e) Remove carburetor attaching bolts and nuts, and remove carburetor and mounting gasket.

(f) Invert carburetor and drain fuel in container.

(g) Place inverted carburetor on suitable holding fixture manifold side up.

CAUTION: Use care to avoid damaging linkage, tubes, and parts protruding from air horn.

(2) Remove idle mixture screw plug.

(a) Using a punch between two locator points in throttle body beneath idle mixture screw plug (manifold side) break out throttle body to gain access to idle mixture screw plug. Drive out hardened steel plug concealing mixture screw.

NOTE: Hardened plug will shatter rather than remaining intact. It is not necessary to remove plug completely; instead, remove loose pieces to allow use of Idle Mixture Adjusting Tool J-29030.

(b) Lightly seat screw and back out 2-1/2 turns for preliminary idle mixture adjustment. Final adjustment must be performed after carburetor is installed.

(c) If plug in air horn covering idle air bleed screw has been removed, turn air bleed screw in until lightly seated, then back out 1-1/4 turns. If plug is in place, removal and adjustment is not required.

(3) Install carburetor on engine. Install battery negative cable. Do not install air cleaner and gasket.

(4) Disconnect bowl vent hose at carburetor.

(5) Disconnect EGR valve and canister purge vacuum hoses at carburetor and plug carburetor ports.

(6) Connect tachometer to distributor "tach" wire connector located at vicinity of heater blower motor. Connect dwell meter to mixture control solenoid dwell test wire connector (fig. 1J-157).

(7) Place transmission in Neutral and set parking brake.

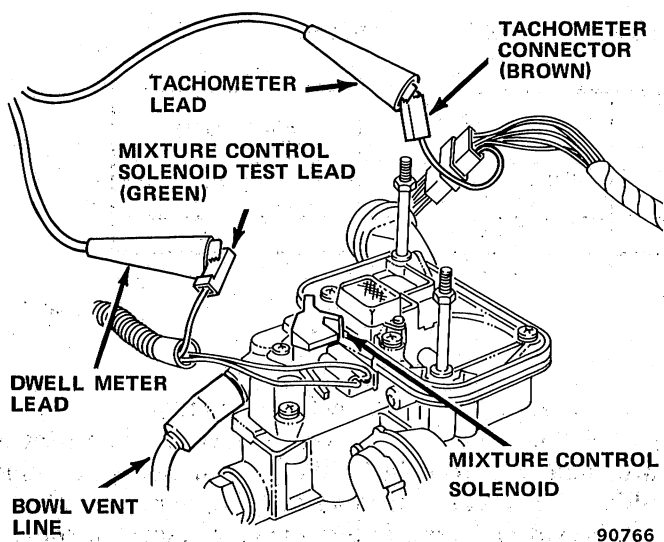

Fig. 1J-157 Idle Mixture Adjustment Preparation

WARNING: Use extreme caution when performing adjustment while engine is operating. The fan, pulleys and belts can cause serious personal injury. Avoid wearing loose clothing. Do not stand in direct line with fan.

(8) Start engine and operate at fast idle for at least three minutes to allow C4 System to switch to Closed Loop Operation.

NOTE: Adjusting Tool J-29030 is required for adjustments.

(9) Return engine to idle and adjust idle speed to 700 rpm.

(10) Adjust idle mixture screw (fig. 1J-158) to obtain an average dwell as specified in Specifications. If dwell is too low, slowly back screw out. If too high, slowly turn in. Allow time for dwell to stabilize after each adjustment. Adjustment is very sensitive. Make final dwell check with adjusting tool removed. If unable to adjust to specification, inspect idle circuit for leaks, restrictions, etc.

(11) Disconnect MC solenoid wire connector and observe tachometer for an engine speed change of at least 50 rpm. If speed does not change enough, inspect idle air bleed circuit for restrictions, leaks, etc. Connect MC Solenoid wire connector.

(12) Connect purge and bowl vent hoses, EGR valve hose, and adjust idle speed according to Emission Control Information label instructions. Remove tachometer and dwell meter.

C4 System Tests and Trouble Code Diagnosis

The self-diagnostic system does not detect all possible faults. The absence of a trouble code does not indicate there is not a malfunction with the system. To determine whether or not a system problem exists, an operational test is necessary. Refer to figure 1J-159 for terminal identification.

NOTE: The System Operational Test should also be performed after all repairs on the C4 System have been completed.

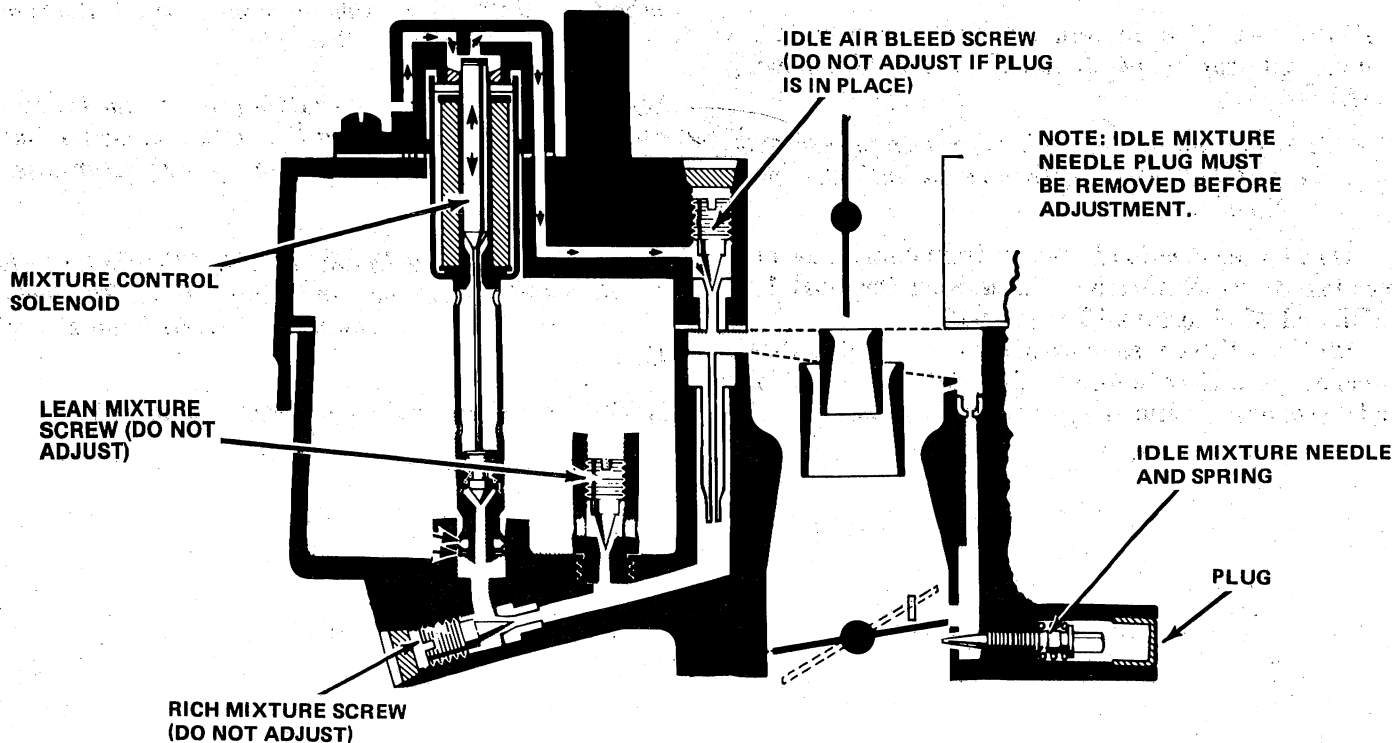

Fig. 1J-158 Model E2SE Carburetor Adjustment Screws

Carburetor Model E2SE Idle Mixture Adjustment Specifications

Transmission	Carburetor Number	Idle Mixture Screw		Idle Air Bleed Screw Preset Turns
		Preset Turns	Dwell	
Manual	17082389	2-1/2	25°	1 - 1/4

90989

Driver Complaints

- **Poor Engine Performance or Fuel Economy**

If the test bulb is not illuminated, normal tests that would be performed on vehicles not equipped with the C4 System should be performed before proceeding to the Operational Test.

- **Alternator Warning Lamp or Coolant Temperature Hot**

If the alternator warning lamp is illuminated or coolant temperature is excessively high along with the test bulb being illuminated, diagnose those problems first. Inspect for faulty connections at coolant temperature sensor, alternator, MC solenoid, etc., and defective or loose vacuum hoses and fittings. Repair as necessary.

- **Intermittent Test Bulb Display**

If the test bulb illuminates intermittently but a trouble code cannot be obtained, inspect the following items.

NOTE: *If for any reason engine speed drops below 200 rpm, the test bulb will be illuminated until the speed exceeds 200 rpm.*

(1) Poor connection in circuit from distributor tach terminal to ECM terminal A, ignition terminal 1 to ECM, and ECM terminal T to ground.

(2) Tach filter resistance should be 14,000 to 18,000 ohms between distributor and ECM terminals (with one end disconnected) and an open circuit to ground.

(3) Low battery voltage (under 9 volts).

(4) Loss of long term memory. Momentarily grounding MC solenoid dwell wire connector with engine idling should cause trouble code 23, which should be retained after engine is stopped and restarted. If voltage is present at long term memory terminal but code was not flashed, ECM is defective.

- **Acceleration Stumble**

Perform Adaptive Vacuum Switch Circuit Test, Chart 7.

- **All Other Complaints**

For all other driver complaints, perform the C4 System Operational Test with engine at normal operating temperature (upper radiator hose hot).

NOTE: *Anytime an engine is first started, even if warm, it must be operated at partial throttle for three minutes or until the tachometer pointer (dwell) starts to vary before proceeding with any test.*

WARNING: *Use extreme caution when engine is operating. Do not stand in direct line with fan. Do not put hands near pulleys, belts or fan. Do not wear loose clothing.*

CAUTION: *The wire leading from the distributor tach terminal to the ECM has an in-series filter. The tachometer must be connected **only** to the distributor side of the filter.*

NOTE: *Install test bulb before performing tests.*

ECM Terminal Connections

VIEW FROM TOP OF BOX

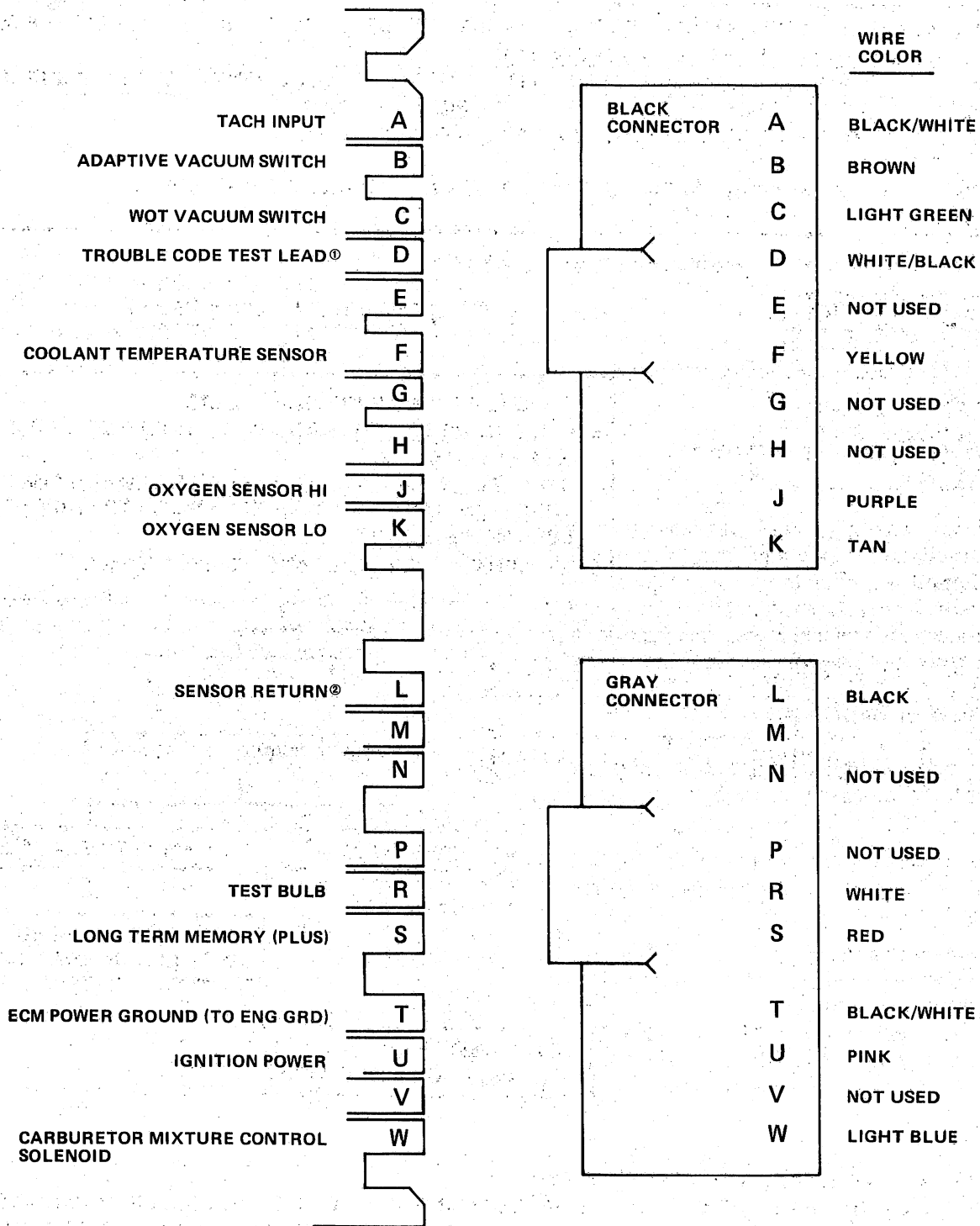

- ① GROUND TO OBTAIN MALFUNCTION CODE
- ② COOLANT, WOT AND ADAPTIVE VACUUM SWITCHES

Fig. 1J-159 ECM Terminal Connections

C4 SYSTEM TESTS AND TROUBLE CODE DIAGNOSIS

Chart 1—C4 System Operational Test

1. INSTALL TEST BULB, TURN IGNITION SWITCH ON, GROUND TROUBLE CODE "TEST" LEAD, OBSERVE CODE.*
2. PLACE TRANSMISSION IN NEUTRAL AND SET PARKING BRAKE.
3. DISCONNECT PURGE HOSE FROM CANISTER AND PLUG. DISCONNECT BOWL VENT HOSE AT CARBURETOR.
4. CONNECT TACHOMETER. (DISTRIBUTOR SIDE OF TACH FILTER, IF USED.)
5. DISCONNECT MIXTURE CONTROL (MC) SOLENOID AND GROUND DWELL LEAD.
6. START ENGINE.
7. RUN ENGINE AT 3,000 RPM AND, WITH THROTTLE CONSTANT, RECONNECT MC SOLENOID.
8. OBSERVE RPM.

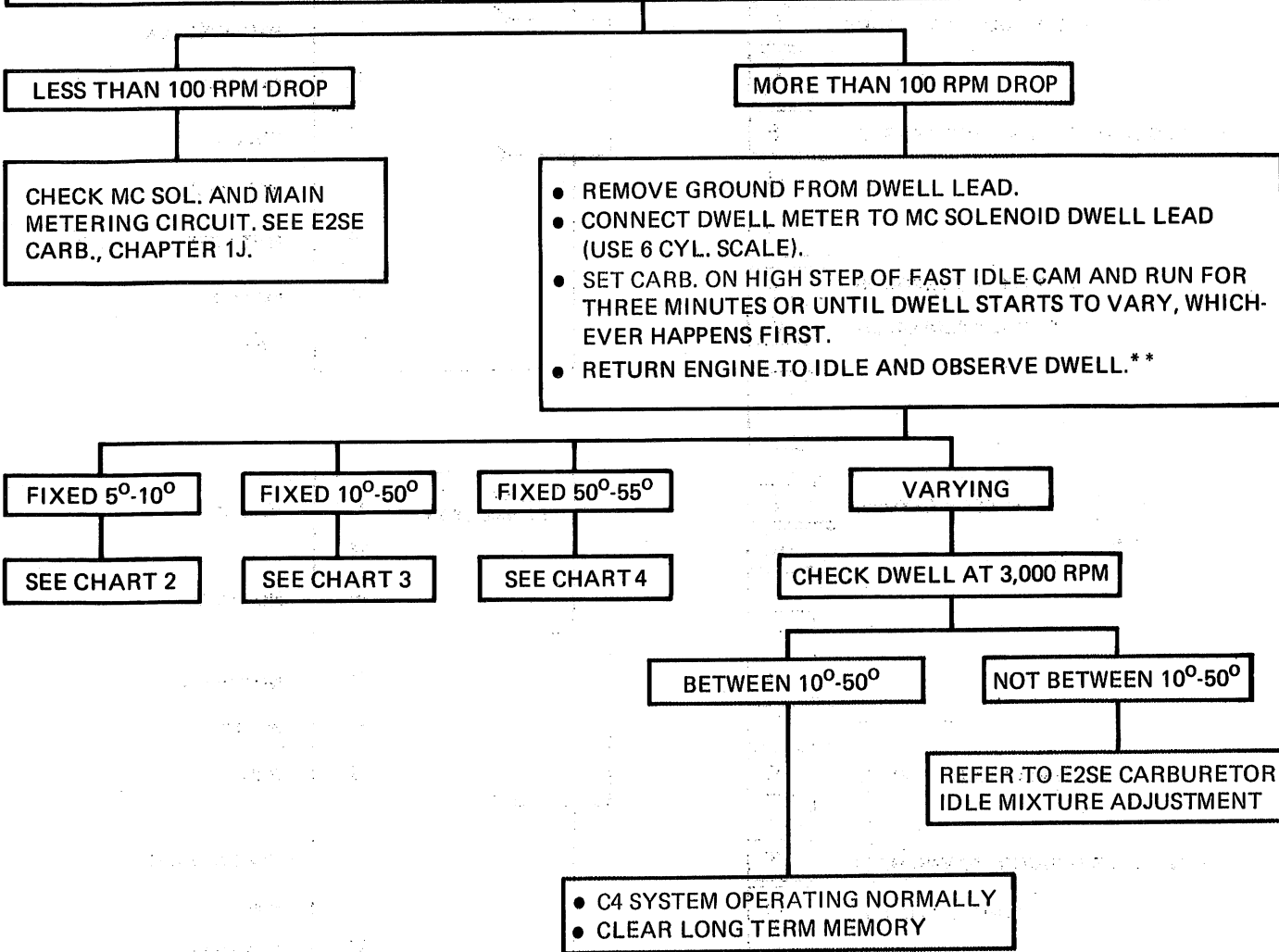

* IF TEST BULB IS NOT ILLUMINATED, SEE CHART 6.

** OXYGEN SENSOR TEMPERATURE MAY COOL AT IDLE CAUSING THE DWELL TO CHANGE FROM VARYING TO A FIXED INDICATION BETWEEN 10°-50°. IF THIS HAPPENS, RUN THE ENGINE AT FAST IDLE TO HEAT THE SENSOR.

Chart 2—Dwell Fixed Between 5 Degrees and 10 Degrees

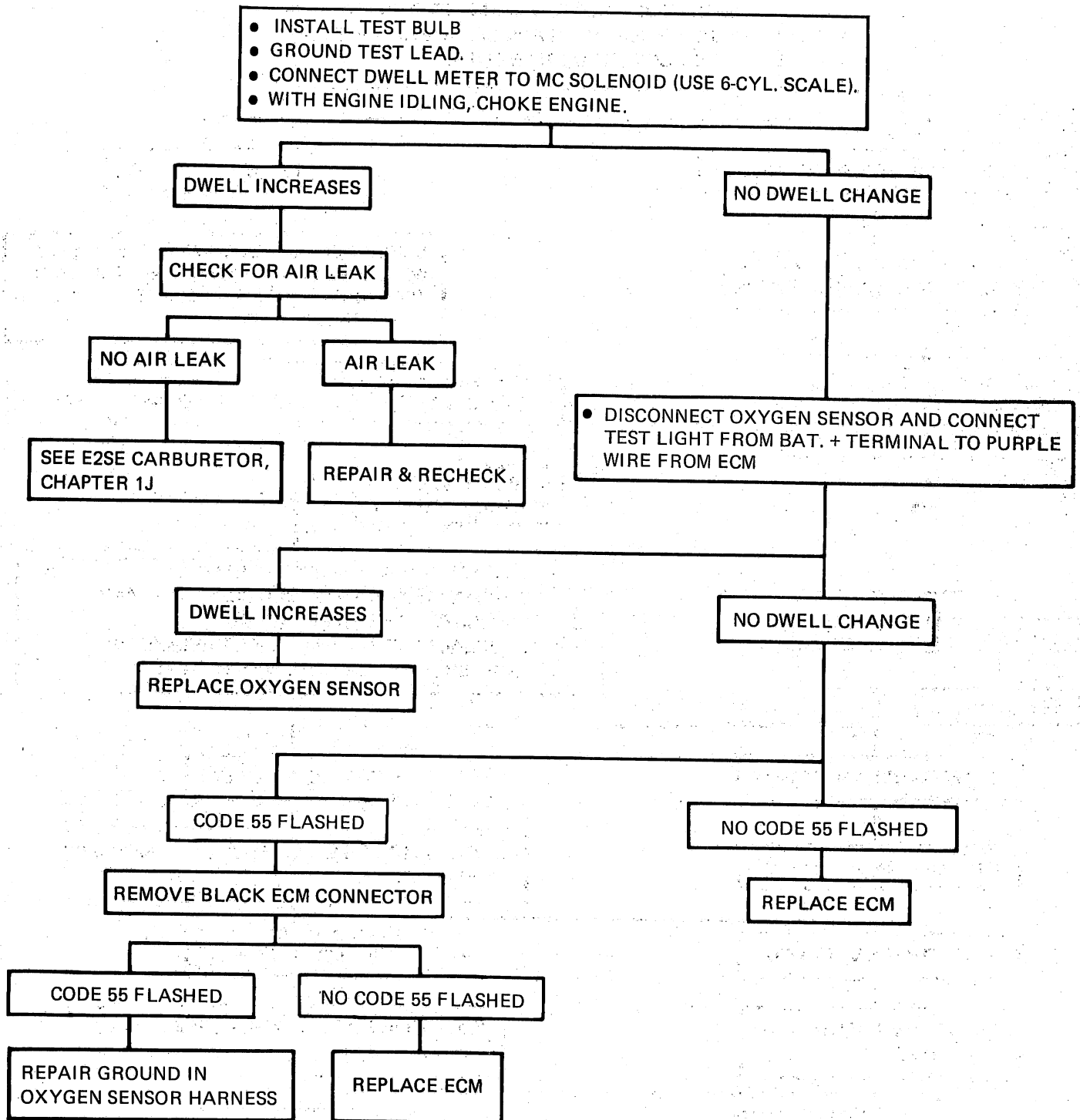

Chart 3—Dwell Fixed Between 10 Degrees and 50 Degrees

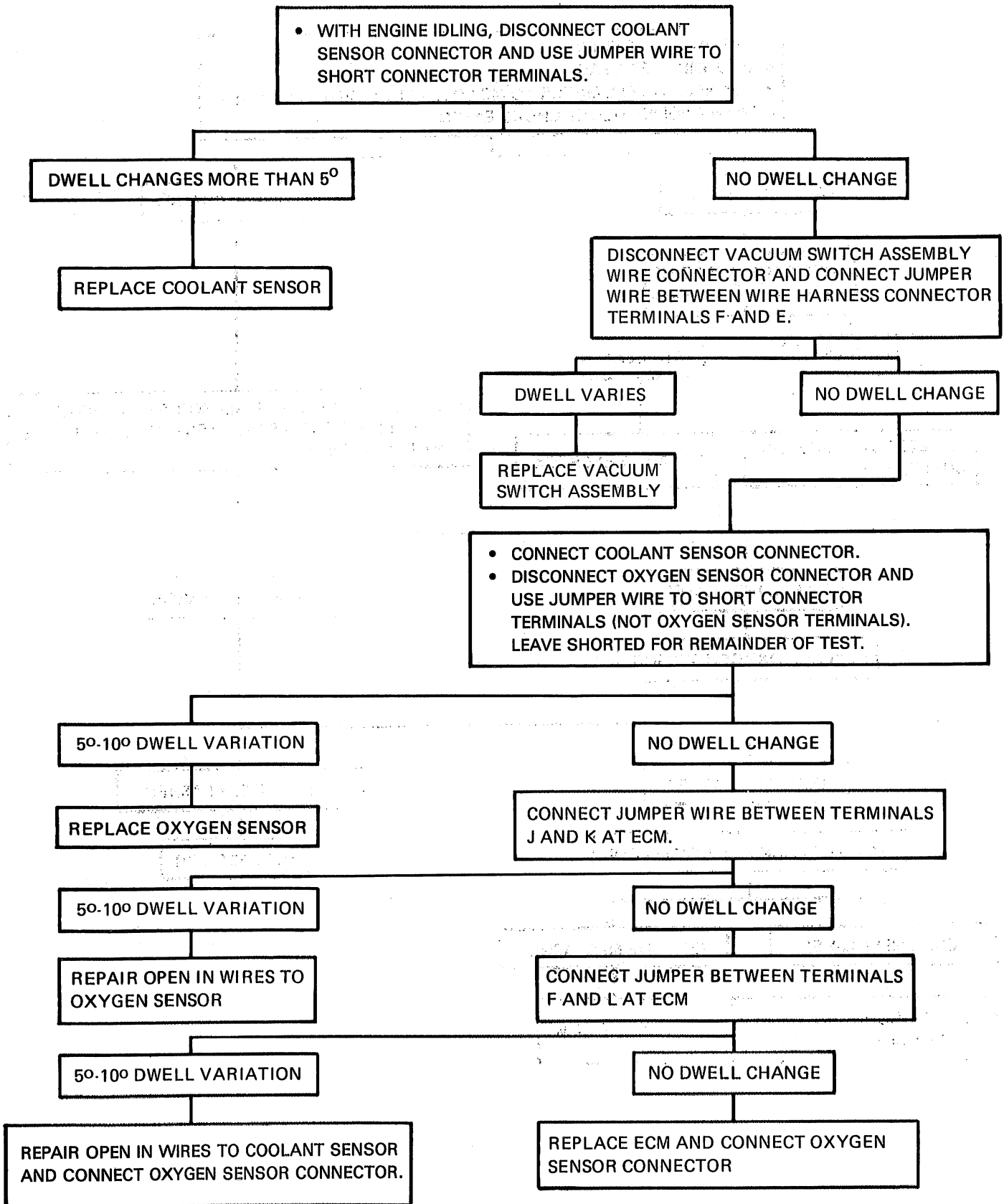

Chart 4—Dwell Fixed Between 50 Degrees and 55 Degrees

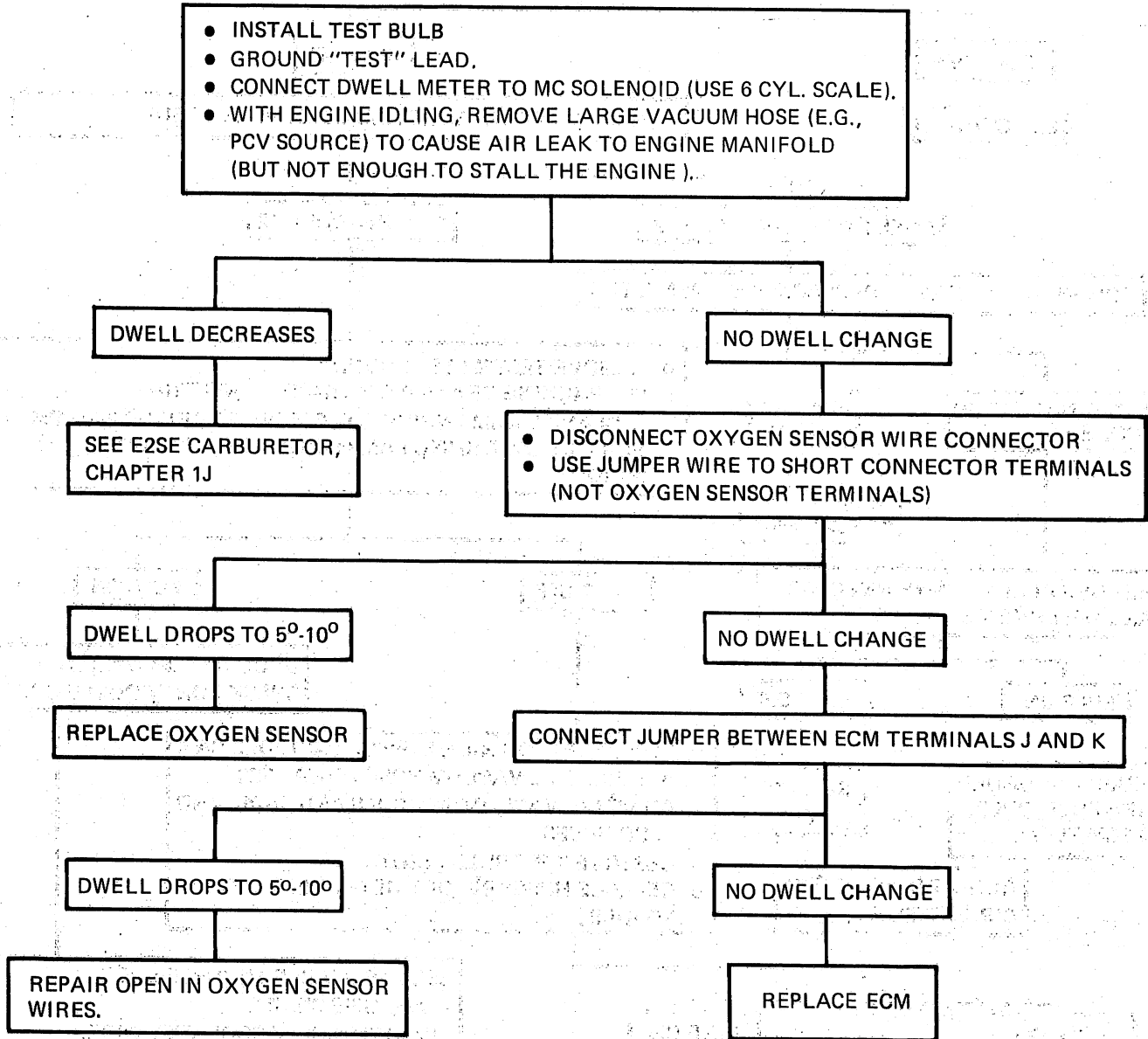

Chart 5—Self-Diagnostic Circuit Test

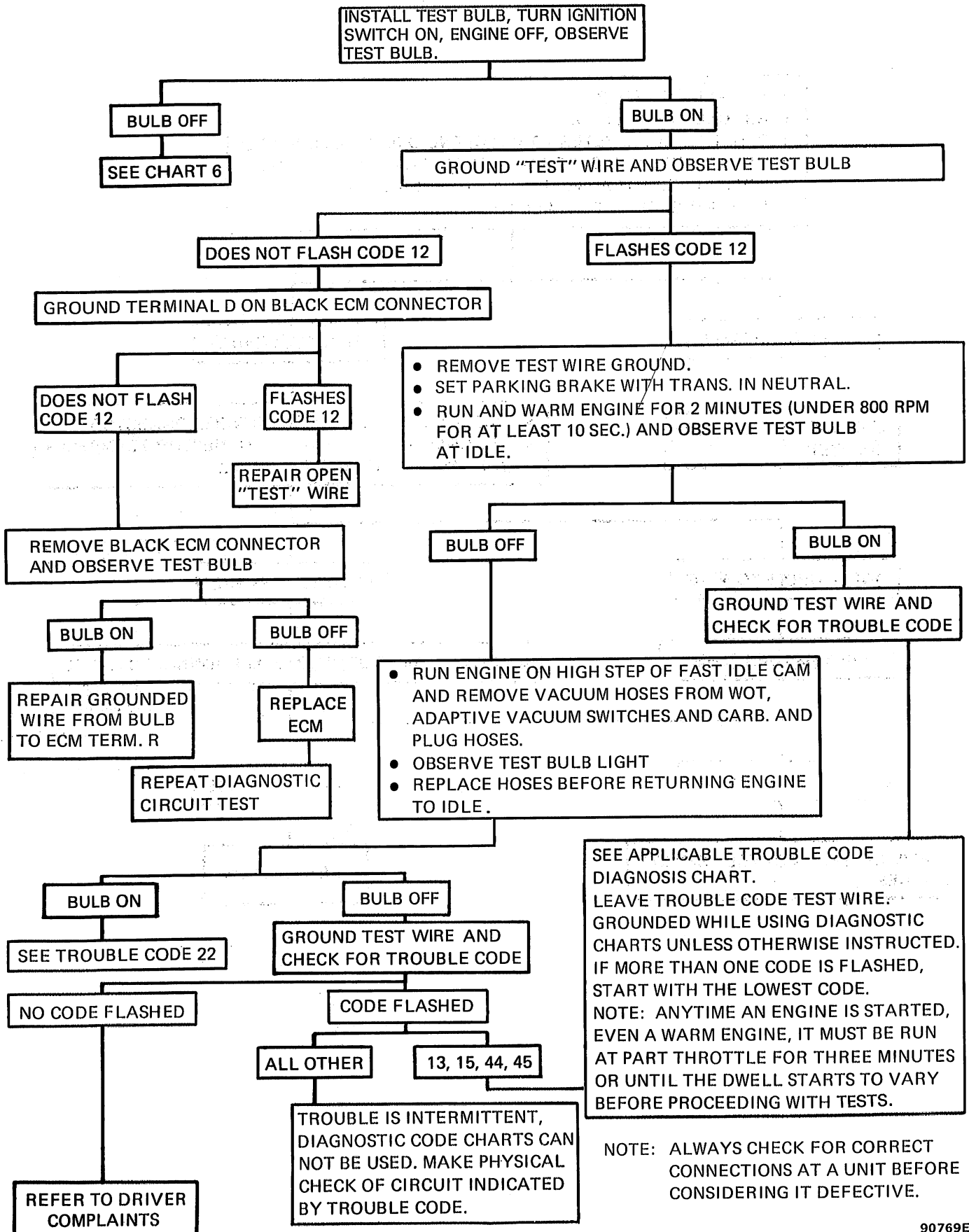

Chart 6—Test Bulb Circuit Inoperative

NOTE: BULB WILL NOT BE ILLUMINATED IF "TEST" WIRE IS GROUNDED BEFORE THE IGNITION IS TURNED ON. THE MC SOLENOID WILL ALSO CLICK.

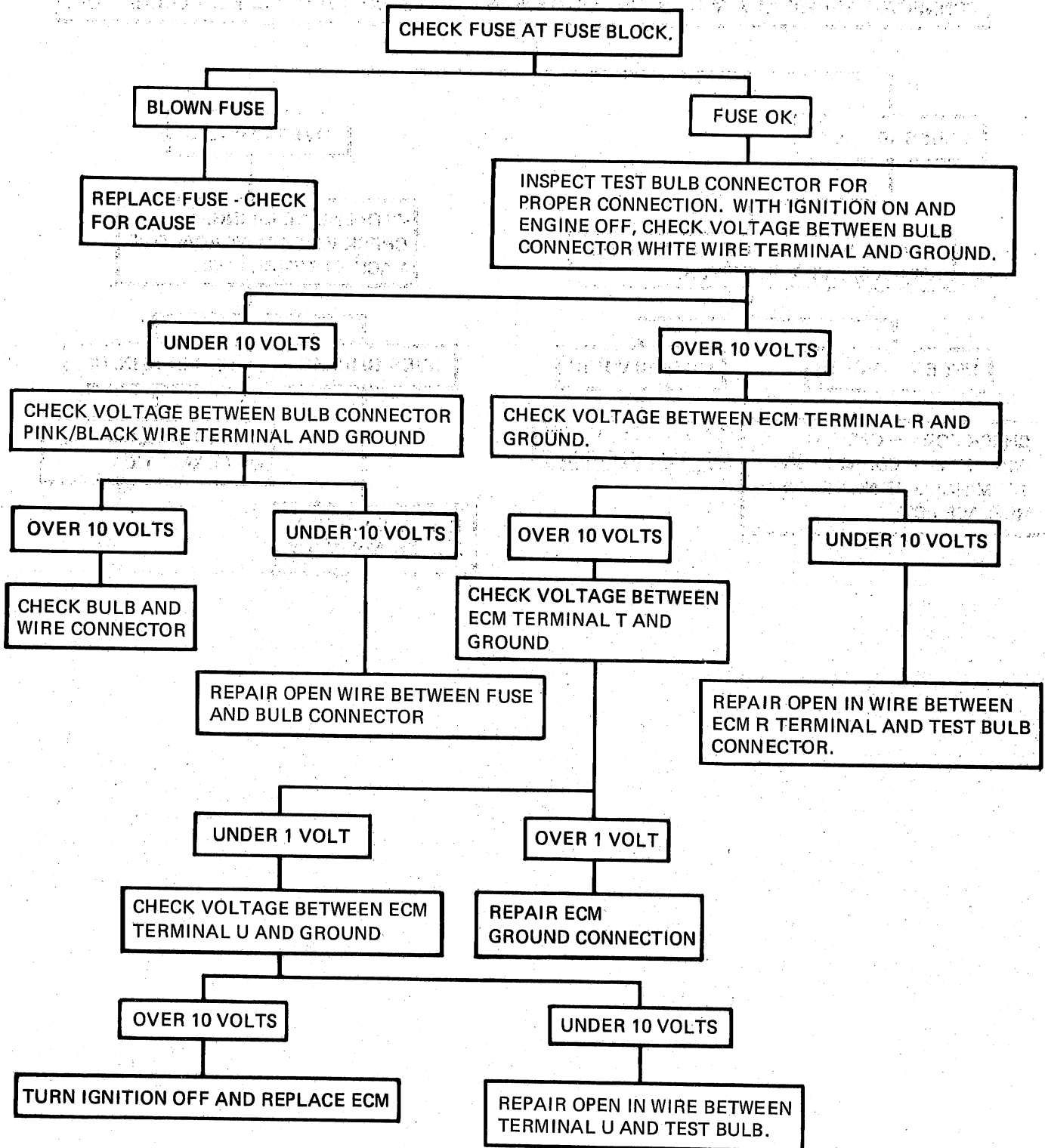
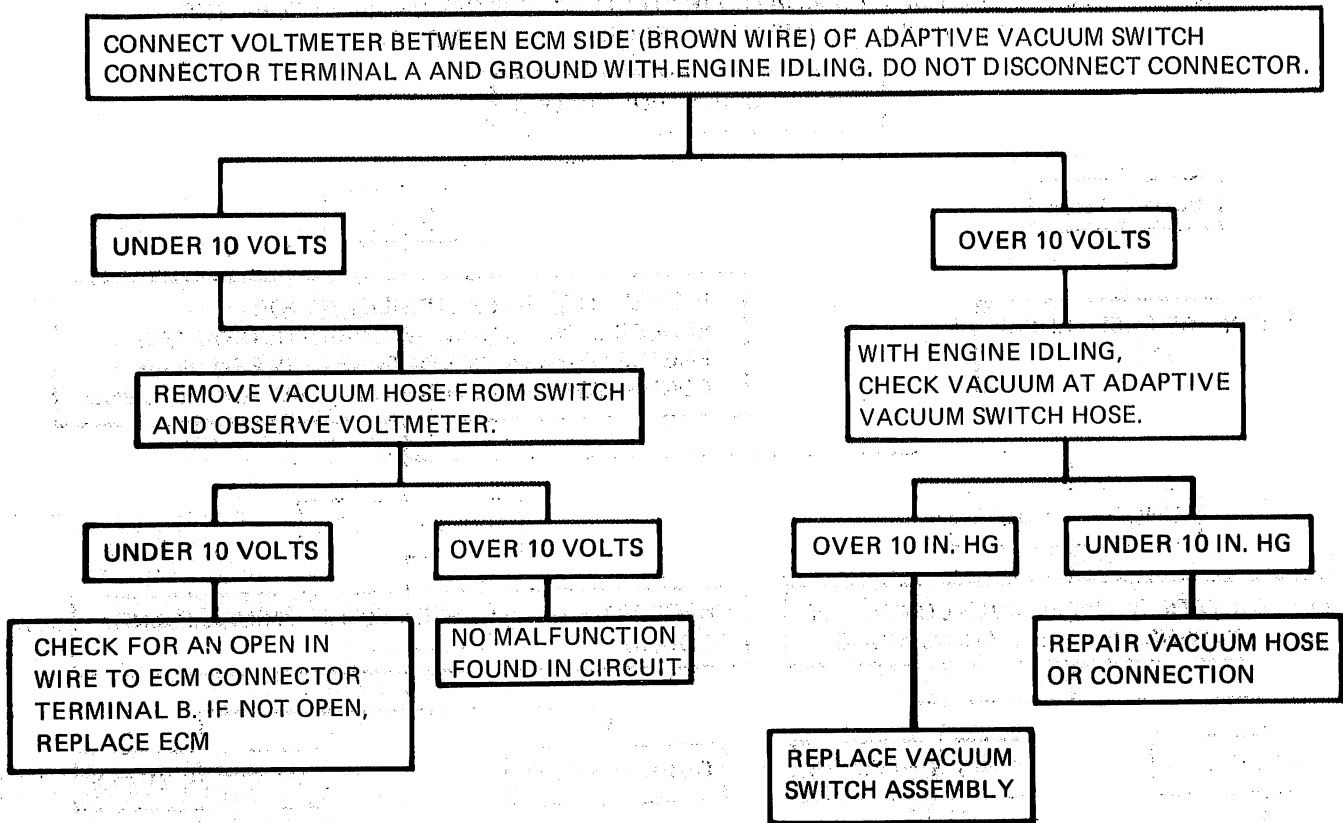
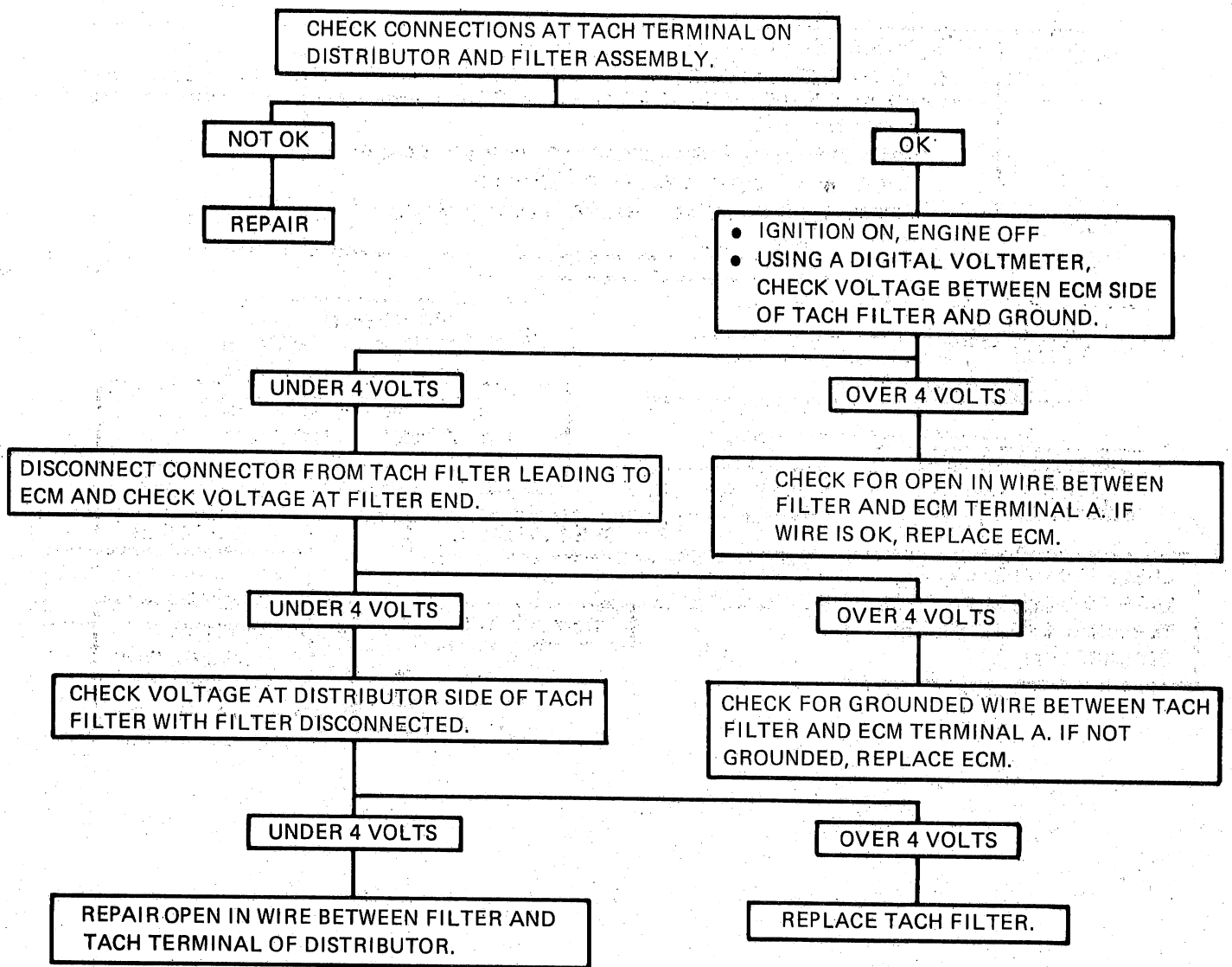

Chart 7—Adaptive Vacuum Switch Circuit Test



TROUBLE CODE 12



TROUBLE CODE 13

- INSTALL TEST BULB
- GROUND "TEST" WIRE.
- CONNECT DWELL METER TO MC SOLENOID (USE 6-CYL. SCALE).
- WITH ENGINE IDLING, DISCONNECT OXYGEN SENSOR CONNECTOR AND CONNECT JUMPER WIRE BETWEEN CONNECTOR TERMINALS (NOT OXYGEN SENSOR TERMINALS).

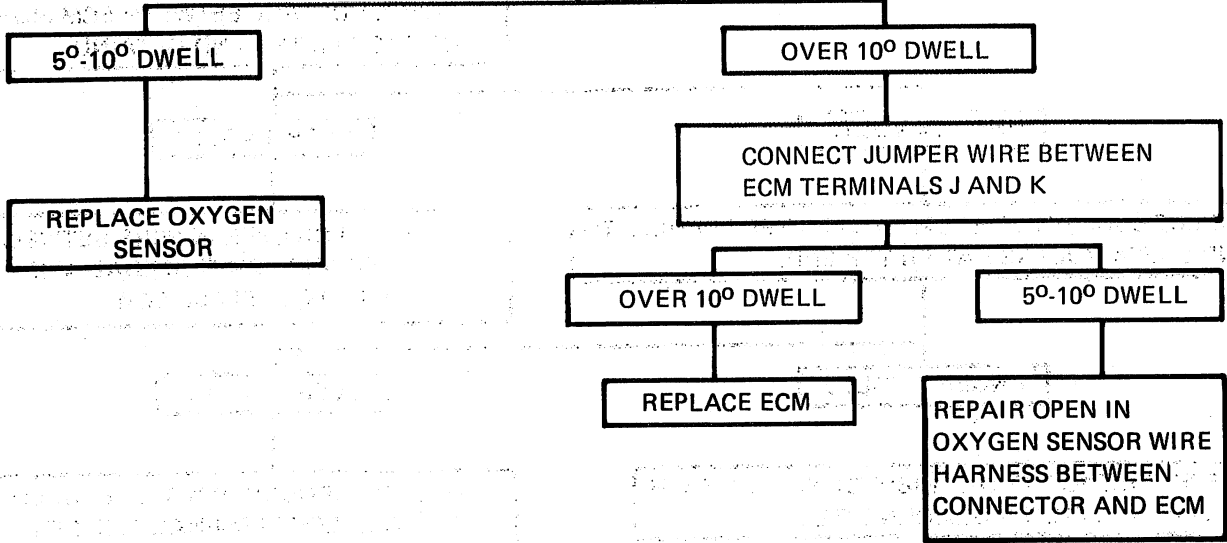

TROUBLE CODE 14

NOTE: IF THE ENGINE COOLANT IS EXCESSIVELY HOT, CHECK FOR CAUSE OF OVERHEATING CONDITION BEFORE PERFORMING THE FOLLOWING TEST.

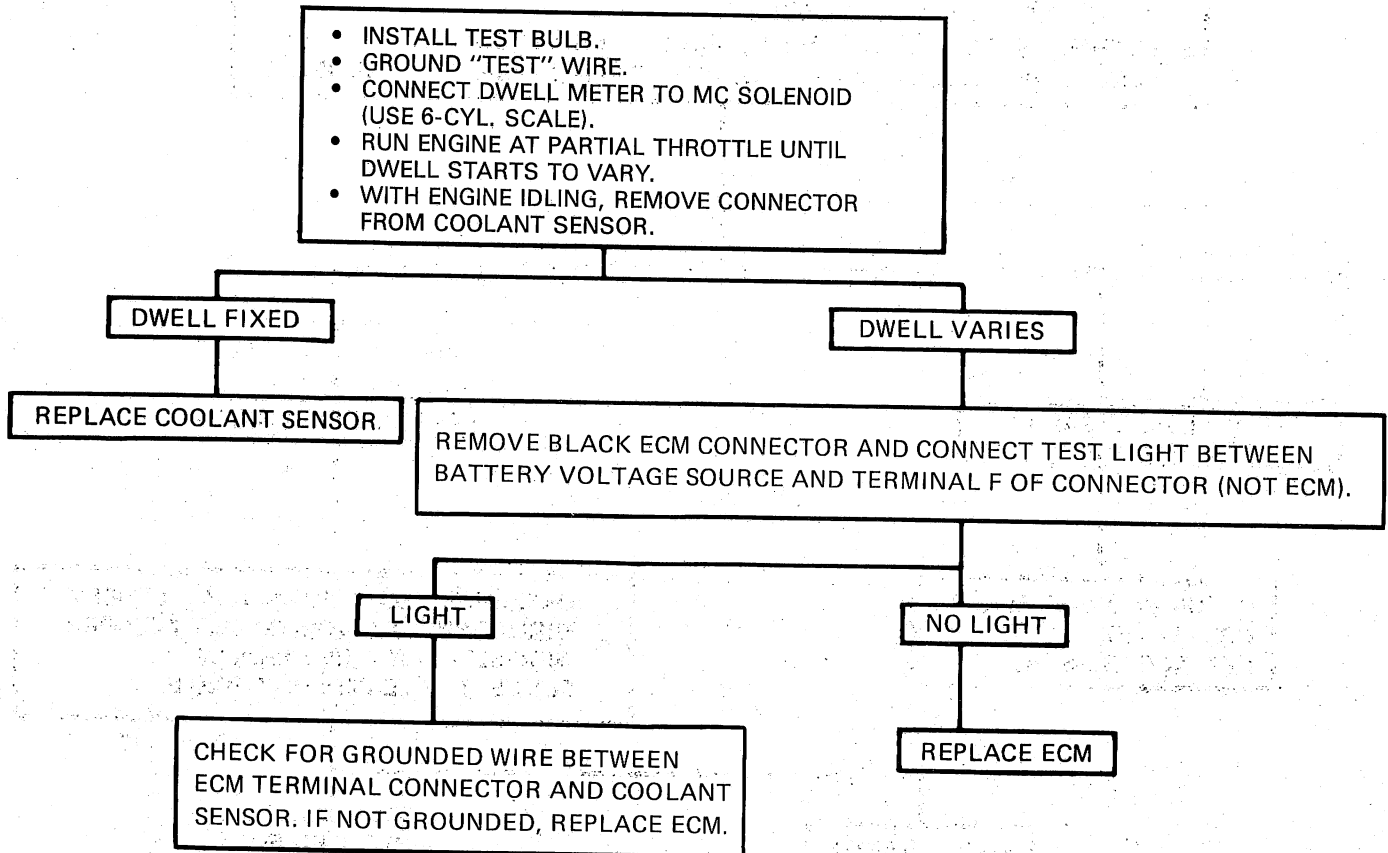

TROUBLE CODE 15

- INSTALL TEST BULB
- GROUND "TEST" WIRE.
- CONNECT DWELL METER TO MC SOLENOID (USE 6 CYL. SCALE)
- STOP AND START ENGINE AND RUN AT PARTIAL THROTTLE FOR 3 MINUTES AND OBSERVE DWELL.
- WITH ENGINE IDLING, REMOVE CONNECTOR FROM COOLANT SENSOR AND CONNECT JUMPER WIRE BETWEEN CONNECTOR TERMINALS.

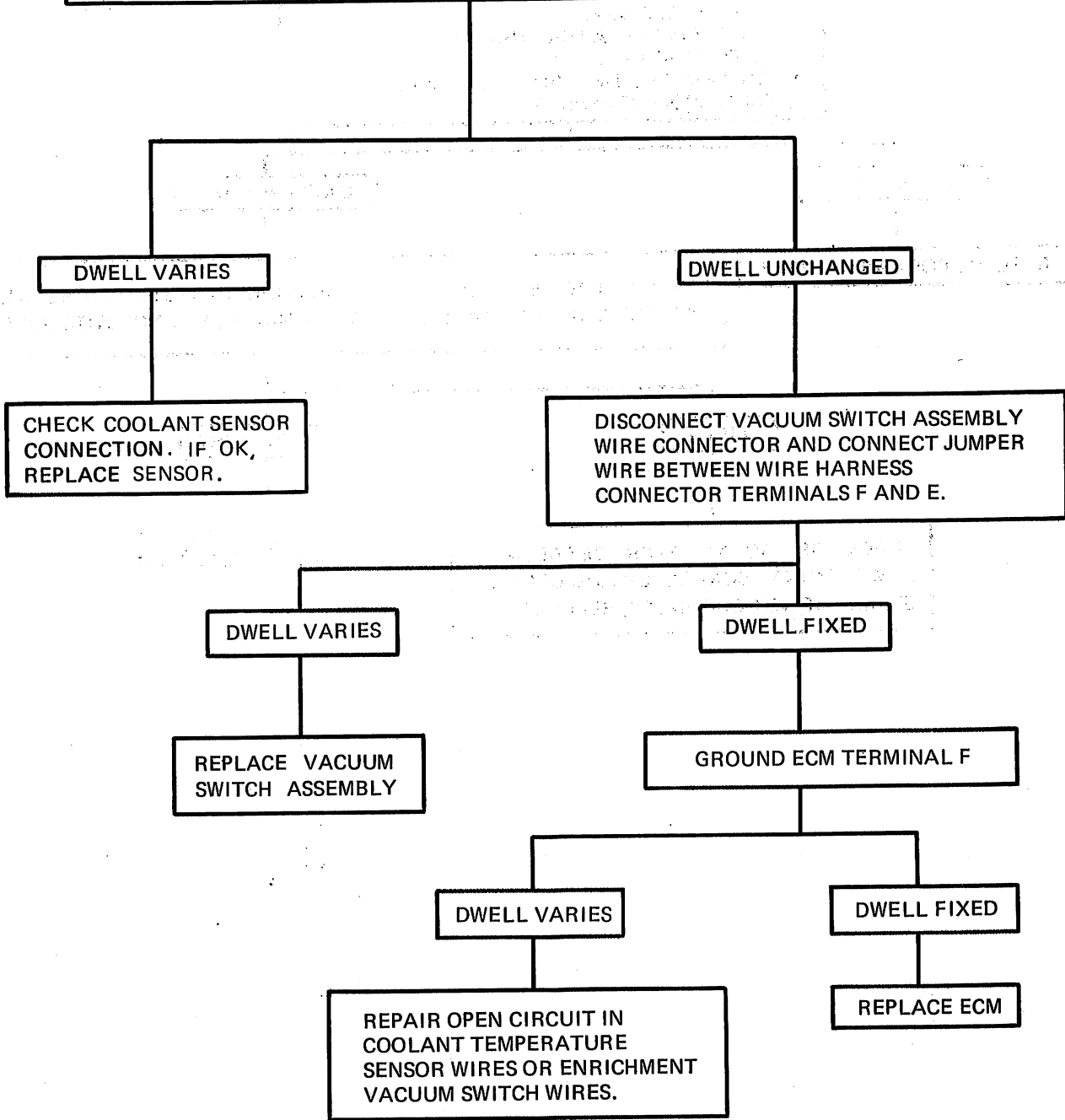

TROUBLE CODE 21 AND 22 TOGETHER

- INSTALL TEST BULB
- GROUND "TEST" WIRE.
- CONNECT DWELL METER TO MC SOLENOID (USE 6-CYL. SCALE).
- WITH ENGINE IDLING, DISCONNECT WOT VACUUM SWITCH CONNECTOR.

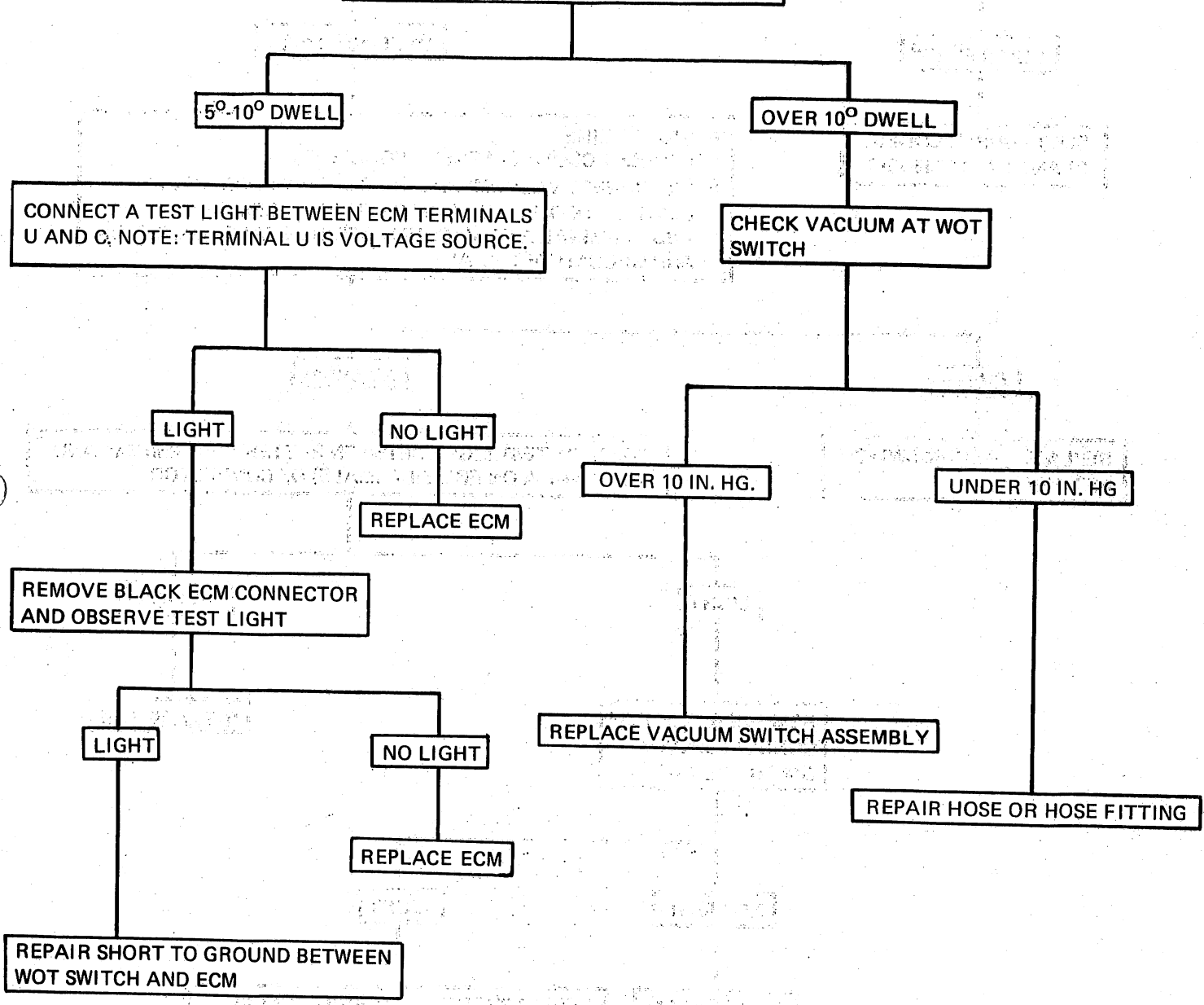

TROUBLE CODE 22

- INSTALL TEST BULB
- DISCONNECT COOLANT SENSOR CONNECTOR.
- GROUND "TEST" WIRE.
- CONNECT DWELL METER TO MC SOLENOID (USE 6-CYL. SCALE).
- WITH ENGINE IDLING, OBSERVE DWELL.

FIXED 5°-10°

SEE TROUBLE CODES 21 AND 22 DIAGNOSIS

OVER 10° DWELL

- STOP ENGINE
- CONNECT COOLANT SENSOR CONNECTOR
- DISCONNECT VACUUM SWITCH ASSEMBLY CONNECTOR
- CONNECT TEST LIGHT FROM BATTERY + TERMINAL AND TERMINAL A OF VACUUM SWITCH FEMALE CONNECTOR AND GROUND TERMINAL B

LIGHT

REPLACE VACUUM SWITCH ASSEMBLY

NO LIGHT

CONNECT TEST LIGHT BETWEEN BATTERY + TERMINAL AND TERMINAL A ON ECM SIDE (MALE) OF CONNECTOR

LIGHT

REMOVE BLACK ECM CONNECTOR AND OBSERVE LIGHT

NO LIGHT

REPLACE ECM

NO LIGHT

REPLACE ECM

LIGHT

REPAIR SHORT TO GROUND IN WIRE HARNESS BETWEEN ECM AND VACUUM SWITCH ASSEMBLY

*OXYGEN SENSORS MAY COOL OFF AT IDLE AND THE DWELL CHANGE FROM VARYING TO FIXED BETWEEN 10°-50°. IF THIS OCCURS, RUNNING THE ENGINE AT FAST IDLE WILL WARM IT UP AGAIN.

TROUBLE CODE 23

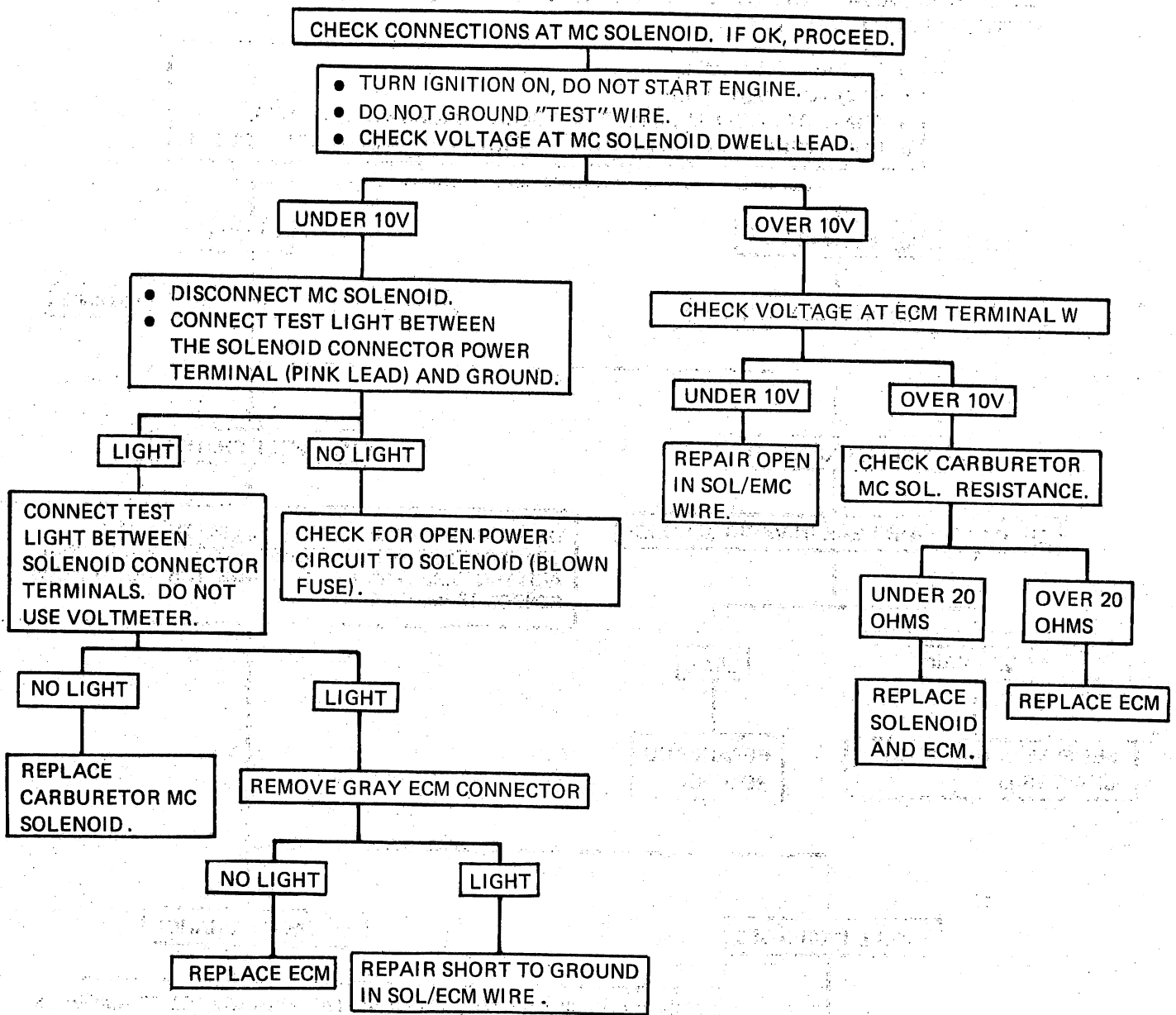

TROUBLE CODE 44

NOTE: IF CODES 44 AND 55 ARE BOTH FLASHED, REPLACE OXYGEN SENSOR AND PERFORM SYSTEM OPERATIONAL TEST.

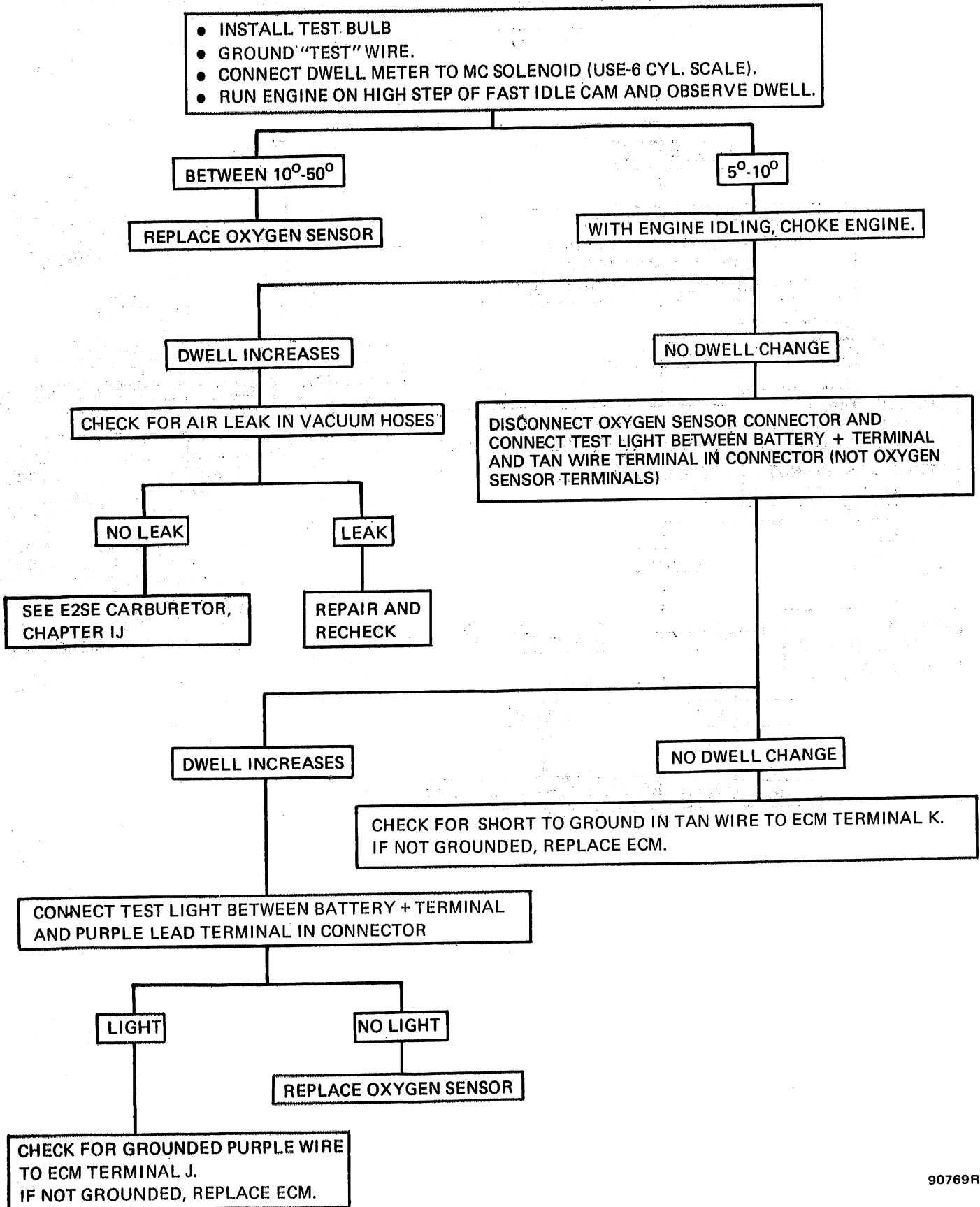

TROUBLE CODE 45

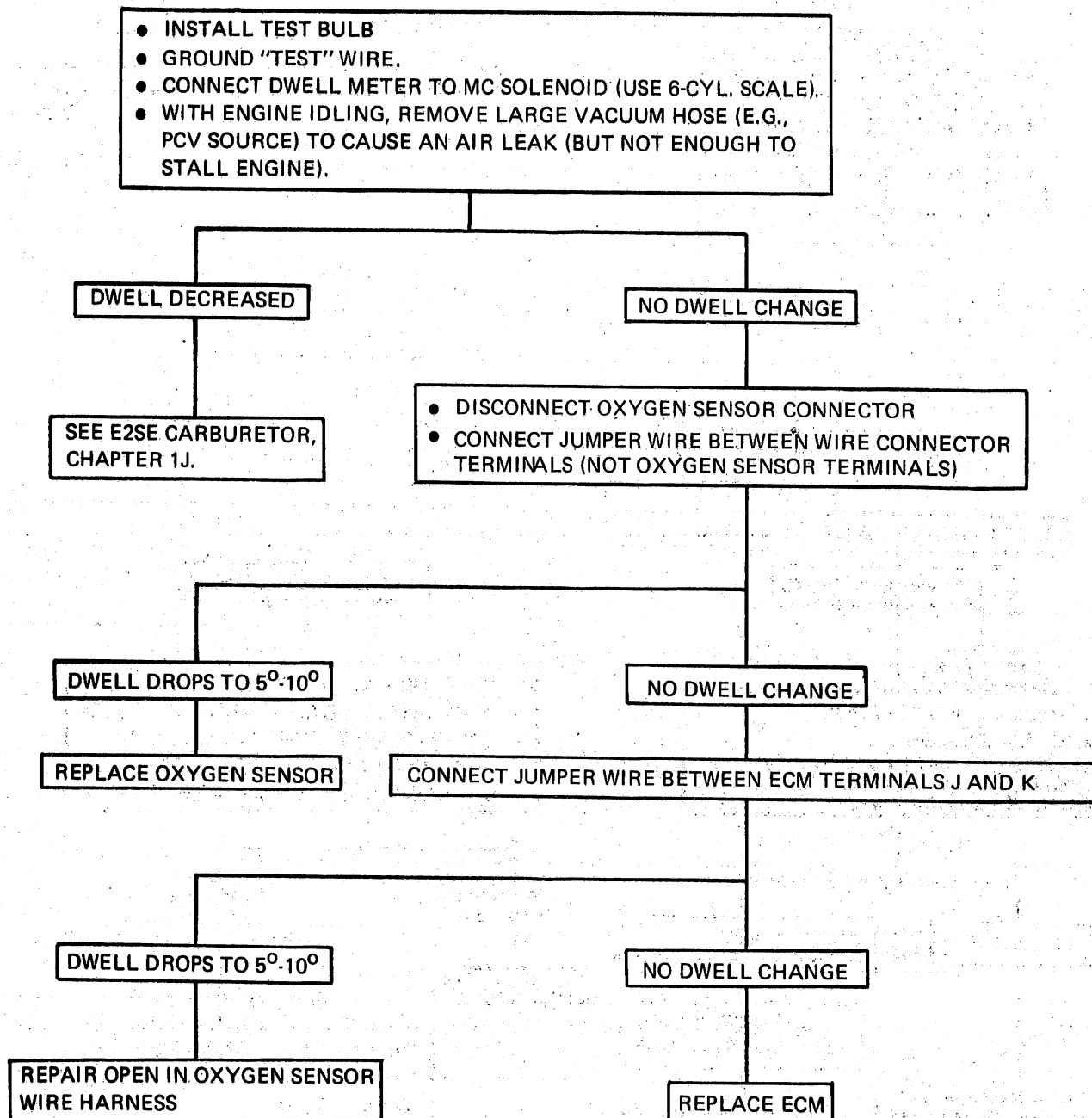

TROUBLE CODE 51-55

TROUBLE CODE 51

CHECK TO ENSURE ALL CALIBRATION UNIT PINS ARE FULLY INSERTED IN THE SOCKET AND ALIGNMENT IS CORRECT. IF OK, REPLACE ECM.

TROUBLE CODES 52-53

REPLACE ECM IF TEST BULB ILLUMINATED. NO TEST BULB LIGHT, INTERMITTENT ECM MALFUNCTION.

TROUBLE CODE 54

CHECK MC SOLENOID RESISTANCE

LESS THAN 20 OHMS

MORE THAN 20 OHMS

- REPLACE MC SOLENOID
- CLEAR MEMORY
- START ENGINE. OBSERVE TEST BULB

- IGNITION ON, ENGINE NOT STARTED
- DISCONNECT MC SOLENOID CONNECTOR
- CONNECT TEST LIGHT FROM GROUND TO DWELL LEAD ON MC SOLENOID
- DISCONNECT GRAY ECM CONNECTOR

NO LIGHT

LIGHT

NO LIGHT

LIGHT

PERFORM SYSTEM OPERATIONAL TEST

GROUND TEST WIRE AND OBSERVE CODE

SEE APPLICABLE CODE DIAGNOSIS

REPLACE ECM

REPAIR SHORT TO POWER SOURCE IN BLUE WIRE LEADING TO ECM TERMINAL W. CLEAR MEMORY AND CHECK FOR OTHER TROUBLE CODES.

TROUBLE CODE 55

CHECK FOR AN OPEN IN OXYGEN SENSOR RETURN WIRE TO ECM TERMINAL K. IF OK, REPLACE ECM.

DIAGNOSTIC PROCEDURES FOR CEC SYSTEM

General

The open loop mode of operation occurs when:

- starting engine, engine is cold or air cleaner air is cold,
- engine is at idle speed,
- carburetor is either at or near wide open throttle (WOT).

When any of these conditions occur, the metering pins are driven to a predetermined programmed position for each condition. Because the positions are predetermined and no feedback from the oxygen sensor relative to the results is accepted, this type of operation is referred to as open loop operation. The five open loop operations are characterized by the metering pins being driven to a position where they are stopped and remain stationary.

Operational Priorities

Each operation (except closed loop) has a specific metering pin position and because more than one of the operation selection conditions can be present at one time, the MCU (microprocessor) is programmed with a priority ranking for the operations. It complies with the conditions that pertain to the operation having the highest priority. The priorities are as listed below.

• Cold Weather Engine Start-up and Operation

If the air cleaner air temperature is below the calibrated value of the thermal electric switch (TES), the stepper motor is positioned a predetermined number of steps rich of the initialization position and air injection is switched upstream. Lean air/fuel mixtures are not permitted for a preset period following a cold weather start-up.

• Open Loop 2, Wide Open Throttle (WOT)

Open Loop 2 is selected whenever the air cleaner air temperature is above the calibrated value of the TES and the WOT switch has been engaged.

When the Open Loop 2 mode is selected, the stepper motor is driven to a calibrated number of steps rich of initialization and the air control valve routes air downstream. However, if the "lean limit" (altitude) jumper wire is installed, the air is instead routed upstream. The WOT timer is activated whenever OL2 is selected and it remains active for a preset period of time. The WOT timer remains inoperative if the "lean limit" (altitude) jumper wire is installed.

• Open Loop 4

Open Loop 4 is selected whenever manifold vacuum falls below a predetermined level. During OL4 operation, the stepper motor is positioned at the initialization position. Air injection is switched upstream during OL4 operation. However, air is diverted downstream if the extended OL4 timer is activated and if the

"lean limit" (altitude) jumper wire is not installed. Air is also diverted downstream if the WOT timer is activated.

• Open Loop 3

Open Loop 3 is selected when the ignition advance vacuum level falls below a predetermined level.

When the OL3 mode is selected, the engine rpm is also determined. If the rpm (tach) voltage is greater than the calibrated value, an engine deceleration condition is assumed to exist. If the rpm (tach) voltage is less than the calibrated value, an engine idle speed condition is assumed to exist.

• Open Loop 1

Open Loop 1 will be selected if the air cleaner air temperature is above a calibrated value and Open Loop 2, 3 or 4 is not selected, and if the engine coolant temperature is below the calibrated value.

The OL1 mode operates in lieu of normal closed-loop operation during a cold engine operating condition. If OL1 operation is selected, one of two predetermined stepper motor positions are chosen, dependent on whether or not the altitude circuit (lean limit) jumper wire is installed.

With each engine start-up, a start-up timer is activated. During this interval, if the engine operating condition would otherwise trigger normal closed loop operation, OL1 operation is selected.

• Closed Loop

Closed loop operation is selected after either OL1, OL2, OL3 or OL4 modes have been selected and the start-up timer has timed out. Air injection is routed downstream during closed loop operation. The predetermined lean mixture ceiling is selected for a preset length of time at the onset of closed loop operation.

Open Loop Operation Predetermined Position Variation

An additional function of the MCU is to correct for a change in ambient conditions (e.g., high altitude). During closed loop operation the MCU stores the number of steps and direction that the metering pins are driven to correct the oxygen content of the exhaust. If the movements are consistently to the same position, the MCU will vary all open loop operation predetermined metering pin positions a corresponding amount. This function allows the open loop air/fuel mixture ratios to be "tailored" to the existing ambient condition during each uninterrupted use of the system. This optimizes emission control and engine performance for the ambient operating condition involved.

Closed Loop Operation

The CEC system controls the air/fuel ratio with movable air metering pins, visible from the top of the carburetor air horn, that are driven by the stepper motor. The stepper motor moves the metering pins in increments or small steps via electrical impulses generated by the MCU. The MCU causes the stepper motor to drive the

metering pins to a richer or leaner position in reaction to the voltage input from the oxygen sensor located in the exhaust manifold. The oxygen sensor voltage varies in reaction to changes in oxygen content present in the exhaust gas. Because the content of oxygen in the exhaust gas indicates the completeness of the combustion process, it is a reliable indicator of the air/fuel mixture that is entering the combustion chamber.

Because the oxygen sensor only reacts to oxygen, any air leak or malfunction between the carburetor and sensor may cause the sensor to provide an erroneous voltage output. This could be caused by a fouled spark plug, manifold air leak or malfunctioning secondary air check valve.

The engine operation characteristics never quite permit the MCU to compute a single metering pin position that constantly provides the optimum air/fuel mixture. Therefore, closed loop operation is characterized by constant movement of the metering pins because the MCU is forced constantly to make small corrections in the air/fuel mixture in an attempt to create an optimum air/fuel mixture ratio.

Idle Speed Control System

The idle speed control system (fig. 1J-161) is interrelated with the CEC System and must be diagnosed in conjunction with CEC System. Refer to Diagnostic Tests 6, 7 and 8, and Chapter 1K if a malfunction occurs.

Electronic Ignition Retard

The electronic ignition retard function of the ignition control module is interrelated with the CEC System and must be diagnosed in conjunction with the CEC System. Refer to Diagnostic Test 4 if a malfunction occurs.

Air Injection System

The air injection system is interrelated with the CEC System and must be diagnosed in conjunction with the CEC System. Refer to Diagnostic Tests 6, 7 and 8, and Chapter 1K if a malfunction occurs.

Initialization

When the ignition system is turned off, the MCU is also turned off. It has no long term memory circuit for prior operation. As a result, it has an initialization function that is activated when the ignition switch is turned On.

The MCU initialization function moves the metering pins to the predetermined starting position by first driving them all the way to the rich end stop and then driving them in the lean direction by a predetermined number of steps. No matter where they were before initialization, they will be at the correct position at the end of every initialization period.

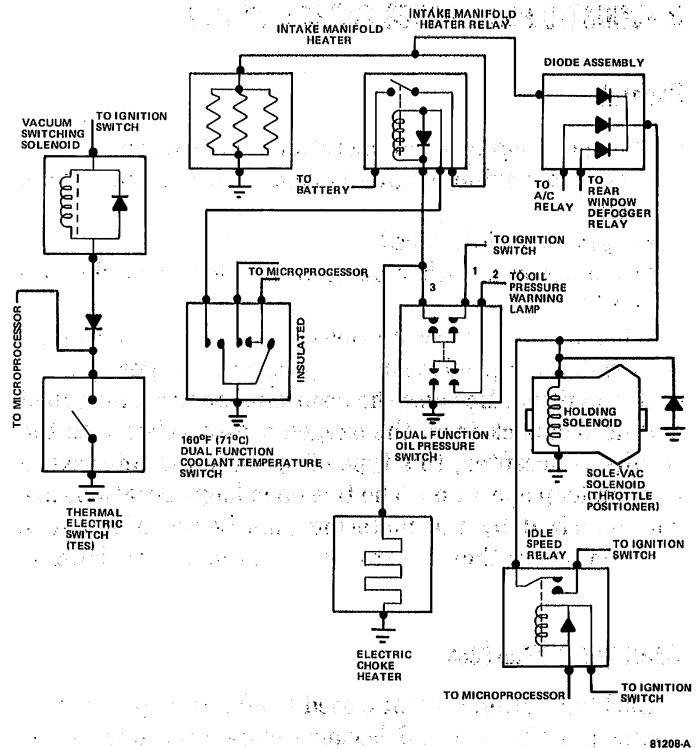

Fig. 1J-161 Idle Speed Control System Diagram

Because each open loop operation metering pin position is dependent on the initialization function, this function is the first test in the diagnostic procedure.

Diagnostic Tests

The CEC System should be considered as a possible source of trouble for engine performance, fuel economy and exhaust emission complaints only after normal tests that would apply to a vehicle without the system have been performed.

The steps in each test will provide a systematic evaluation of each component that could cause the operational malfunction.

After completing a repair, repeat the test to ensure the malfunction has been eliminated.

The equipment required to perform the tests is a tachometer, a hand vacuum pump, a digital volt-ohm-meter (DVOM) with a minimum ohms-per-volt input impedance of 10 meg-ohms and jumper wires.

WARNING: When performing system diagnostic tests, the following safety precautions **must** be followed:

(1) Shape a sheet of clear acrylic plastic at least 0.250-inch thick and 15 inches x 15 inches, as depicted in figure 1J-162.

(2) Secure acrylic sheet with air cleaner wing nut after top of air cleaner has been removed.

(3) Wear eye protection whenever performing tests.

(4) When engine is operating, keep hands and arms clear of fan, drive pulleys and belts. Do not wear loose clothing. Do not stand in direct line with fan blades.

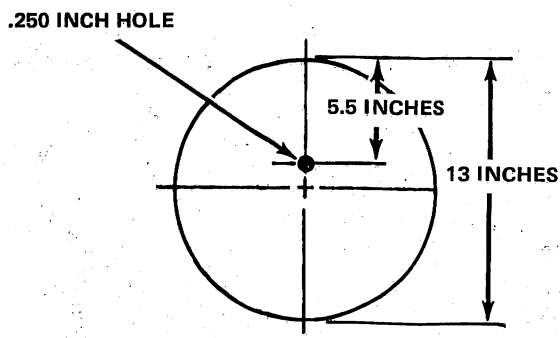
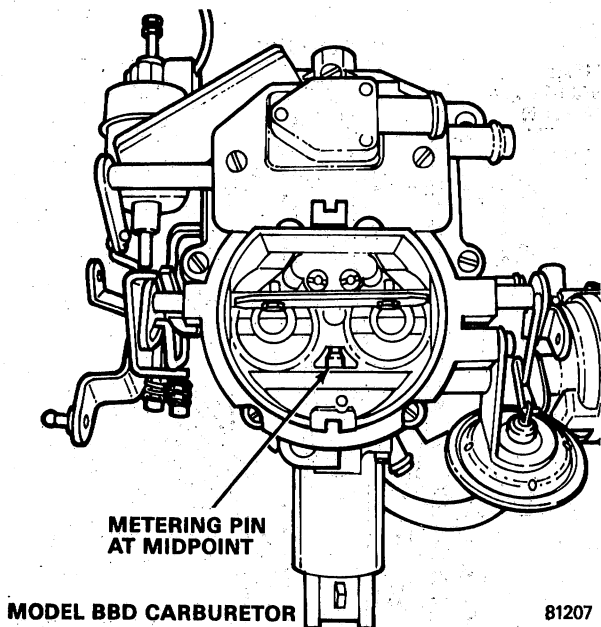

90759

Fig. 1J-162 Air Cleaner Cover and Metering Pin Location

Diagnostic Test 1: Initialization

(1) Remove air cleaner cover. Observe WARNING above. Follow test procedure outlined in Test 1. Refer to

figures 1J-163, 1J-164, 1J-165, 1J-166, 1J-167, and 1J-168.

NOTE: The metering pins operate in tandem. Only the upper pin is visible.

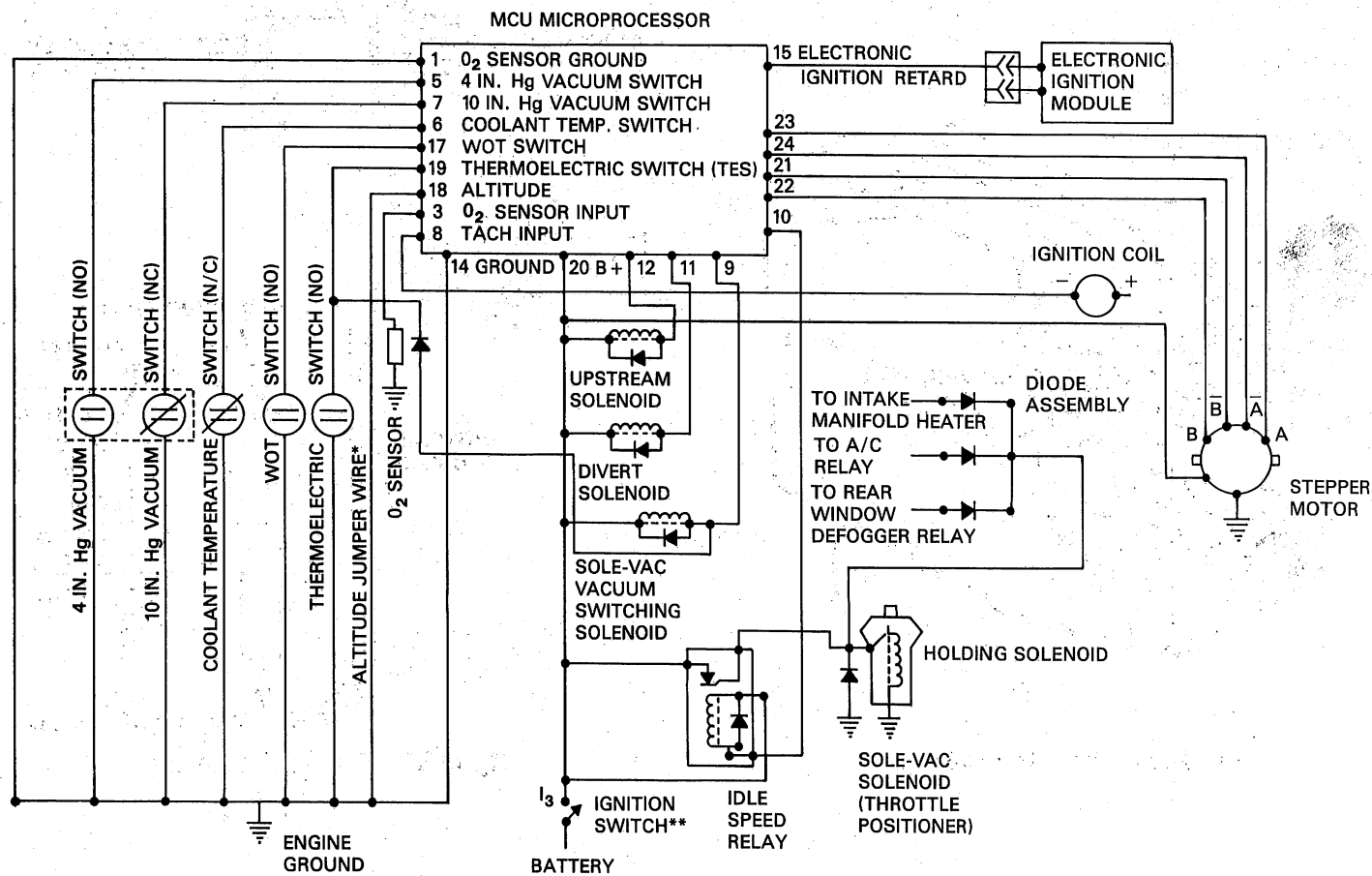

*IF EQUIPPED
**OFF DURING ENGINE START-UP

90760B

Fig. 1J-163 CEC System Wiring Diagram

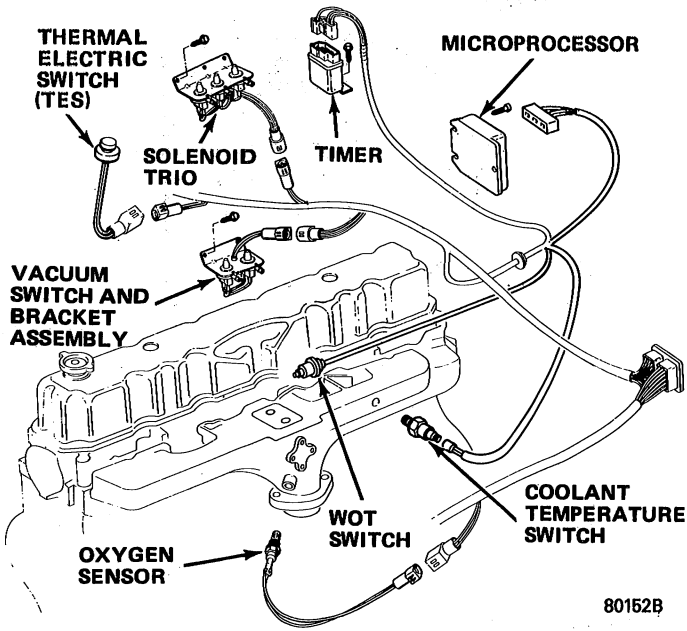

Fig. 1J-164 CEC System

80152B

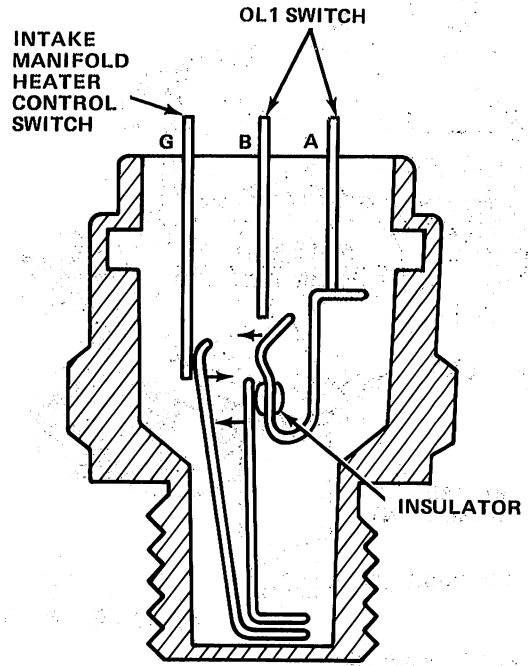

Fig. 1J-166 Coolant Temperature Switch

81146

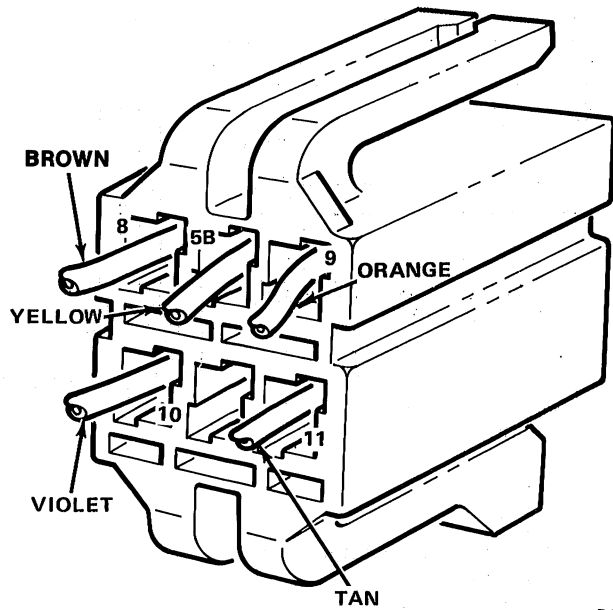
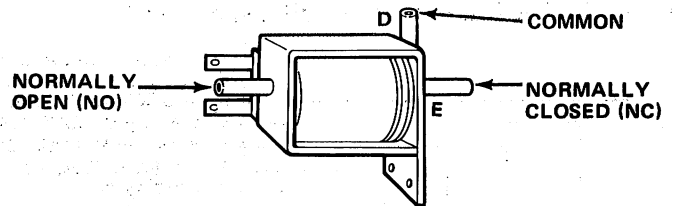

Fig. 1J-165 Stepper Motor Connector

81144

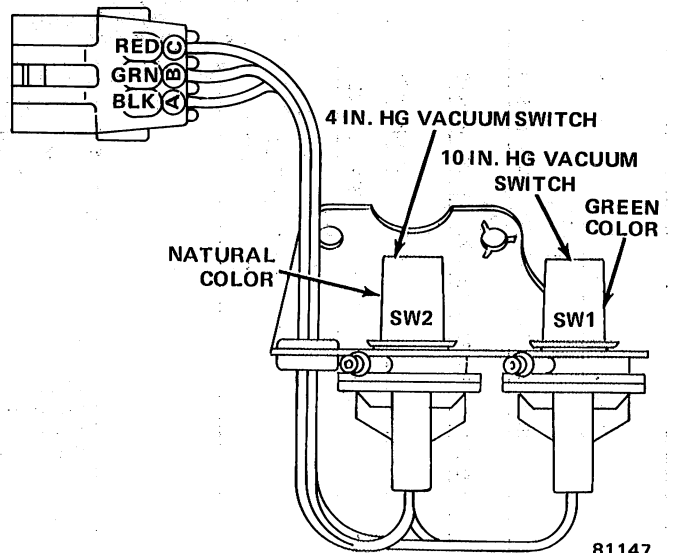

Fig. 1J-167 Vacuum Switch Assembly

81147

Test Results

If after completing the Tests the problem persists, other engine associated systems that can affect air/fuel mixture, combustion efficiency or exhaust gas composition can be causing the fault. These systems include:

- basic carburetor adjustments;

- mechanical engine operation (i.e., plugs, valves, rings);
- ignition System;
- gaskets (intake manifold, carburetor or base plate);
- loose vacuum hoses or fittings.

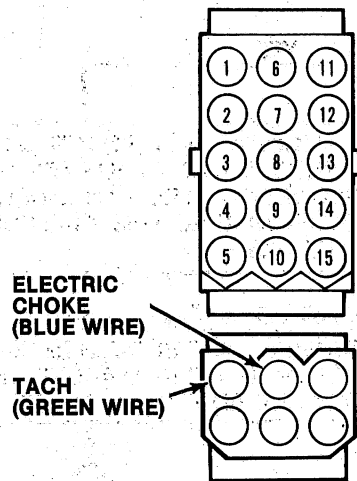

DIAGNOSTIC CONNECTOR

1. 4 IN. HG VACUUM SWITCH
2. COOLANT TEMP. SWITCH
3. 10 IN. HG VACUUM SWITCH
4. WOT SWITCH
5. ALTITUDE JUMPER WIRE
6. STEPPER MOTOR A ϕ
7. STEPPER MOTOR B ϕ
8. UPSTREAM SOLENOID
9. DIVERT SOLENOID
10. VACUUM SWITCHING SOLENOID
11. IDLE SPEED RELAY
12. THERMAELECTRIC SWITCH (TES)
13. GROUND
14. B+ (12V)
15. SOLE-VAC SOLENOID

81196

Fig. 1J-168 Diagnostic Connector

DIAGNOSTIC TEST 1

INITIALIZATION TEST.

REMOVE AIR CLEANER COVER.

NOTE: WHEN APPLICABLE, DIAGNOSTIC CONNECTOR TERMINALS CAN BE USED AS TEST POINTS INSTEAD OF MCU HARNESS CONNECTOR TERMINALS.

WHILE OBSERVING METERING PINS, HAVE HELPER TURN IGNITION SWITCH TO ON POSITION WITHOUT STARTING ENGINE. METERING PINS SHOULD MOVE FULLY TOWARD THE FRONT OF ENGINE, REVERSE DIRECTION AND MOVE PARTIALLY BACK TOWARD REAR, STOP AND REMAIN STATIONARY.

OK?

NO

YES

DISCONNECT WIRE HARNESS CONNECTOR FROM MCU.

TURN IGNITION OFF. LOCATE AIR CLEANER MOUNTED THERMAL ELECTRIC SWITCH (TES) AND DISCONNECT IT FROM WIRE HARNESS. INSTALL A JUMPER WIRE ACROSS WIRE CONNECTOR TERMINALS.

WITH THE IGNITION ON, TEST PIN 20 OF HARNESS CONNECTOR FOR BATTERY VOLTAGE.

START ENGINE AND OBSERVE METERING PINS. METERING PINS SHOULD REPEAT INITIALIZATION PROCESS DESCRIBED ABOVE, THEN MOVE FORWARD ADDITIONAL STEPS.

OK ?

YES

NO

YES

NO

REMOVE JUMPER WIRE AND CONNECT TES. CONNECTOR. TEST COMPLETE.

REMOVE JUMPER WIRE AND CONNECT TES. CONNECTOR. TEST TACH INPUT TO MCU AT PIN 8.

TEST PIN 14 FOR CONTINUITY TO GROUND. CHECK HARNESS GROUND FOR TIGHT CONNECTION AT RIGHT SIDE OF CYLINDER BLOCK.

REPAIR AND START TEST OVER.

YES

NO

TEST FOR SHORT CIRCUIT BETWEEN PIN 8 (TACH) AND PIN 19 (TES) OF MCU HARNESS CONNECTOR.

REPAIR TACH WIRE FROM IGN. COIL. RETEST.

CONT'D.

SHORT CIRCUIT ?

YES

NO

REPAIR SHORT CIRCUIT AND RETEST.

REPLACE MCU AND RETEST.

CONTINUED
FROM PREVIOUS
PAGE



REPAIR AND RETEST.

TURN OFF IGNITION AND TEST RESISTANCE BETWEEN PIN 20 AND PINS 23, 24, 21 AND 22 AT MCU HARNESS CONNECTOR.

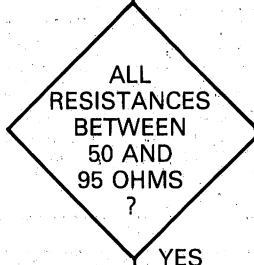

TURN IGNITION ON AND DISCONNECT STEPPER MOTOR CONNECTOR.

REPEAT RESISTANCE TEST USING PIN 14 INSTEAD OF 20. ALL RESISTANCES SHOULD BE EQUAL TO OR SLIGHTLY HIGHER THAN THOSE INDICATED IN PREVIOUS TEST.

TEST FOR BATTERY VOLTAGE AT PIN 5 OF THE STEPPER MOTOR CONNECTOR.

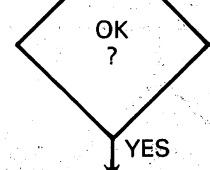
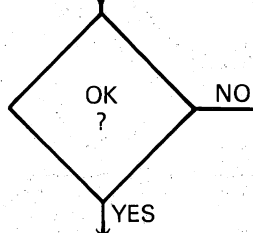

REMOVE STEPPER MOTOR AND INSPECT FOR EVIDENCE OF PIN BINDING.

TURN IGNITION OFF AND TEST FOUR REMAINING STEPPER MOTOR CONNECTOR PINS FOR SHORT TO GROUND. ALL SHOULD INDICATE AN OPEN CIRCUIT (INFINITE RESISTANCE).

WITH MOTOR REMOVED, TURN IGNITION ON, OBSERVE PIN MOVEMENT.

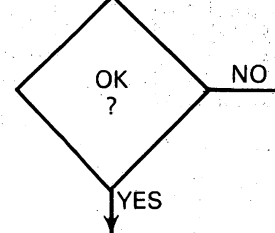

WHEN IGNITION IS FIRST TURNED ON, STEPPER MOTOR PINS MOVE TO FULL FORWARD (RICH) POSITION THEN BACK TO HALF-WAY POSITION.

TEST FOR CONTINUITY FROM PINS 23, 24, 21 AND 22 AT MCU CONNECTOR TO APPROPRIATE PINS AT STEPPER MOTOR CONNECTOR. INSPECT STEPPER MOTOR CONNECTOR FOR CORRECT COLOR ORIENTATION OF WIRES.

CONT'D.

CONT'D.

CONTINUED
FROM PREVIOUS
PAGE

YES OK ? NO

REPAIR STEPPER MOTOR
PIN BINDING DEFECT.

REPLACE MCU AND
RETEST STEPPER MOTOR.

CONTINUED
FROM PREVIOUS
PAGE

NO CONTINUITY
AND WIRES
OK? YES

REPAIR AND START TEST
OVER.

REPLACE STEPPER MOTOR.

DIAGNOSTIC TEST 2

NOTE: ENGINE SHOULD BE AT NORMAL OPERATING TEMPERATURE.

NOTE: CONTINUITY TESTING WITH MCU CONNECTED TO THE SYSTEM SHOULD INDICATE 2 OHMS. WHEN THE MCU IS DISCONNECTED FROM THE SYSTEM, ALL CONTINUITY SHOULD INDICATE LESS THAN 1 OHM. WHEN APPLICABLE, DIAGNOSTIC CONNECTOR TERMINALS CAN BE USED AS TEST POINTS INSTEAD OF MCU HARNESS CONNECTOR TERMINALS.

OPEN LOOP SWITCH TEST

USING A STANDARD VOLT-OHMMETER, TEST FOR CONTINUITY FROM THE DIAGNOSTIC CONNECTOR PIN 13 TO MCU CONNECTOR PIN 14.

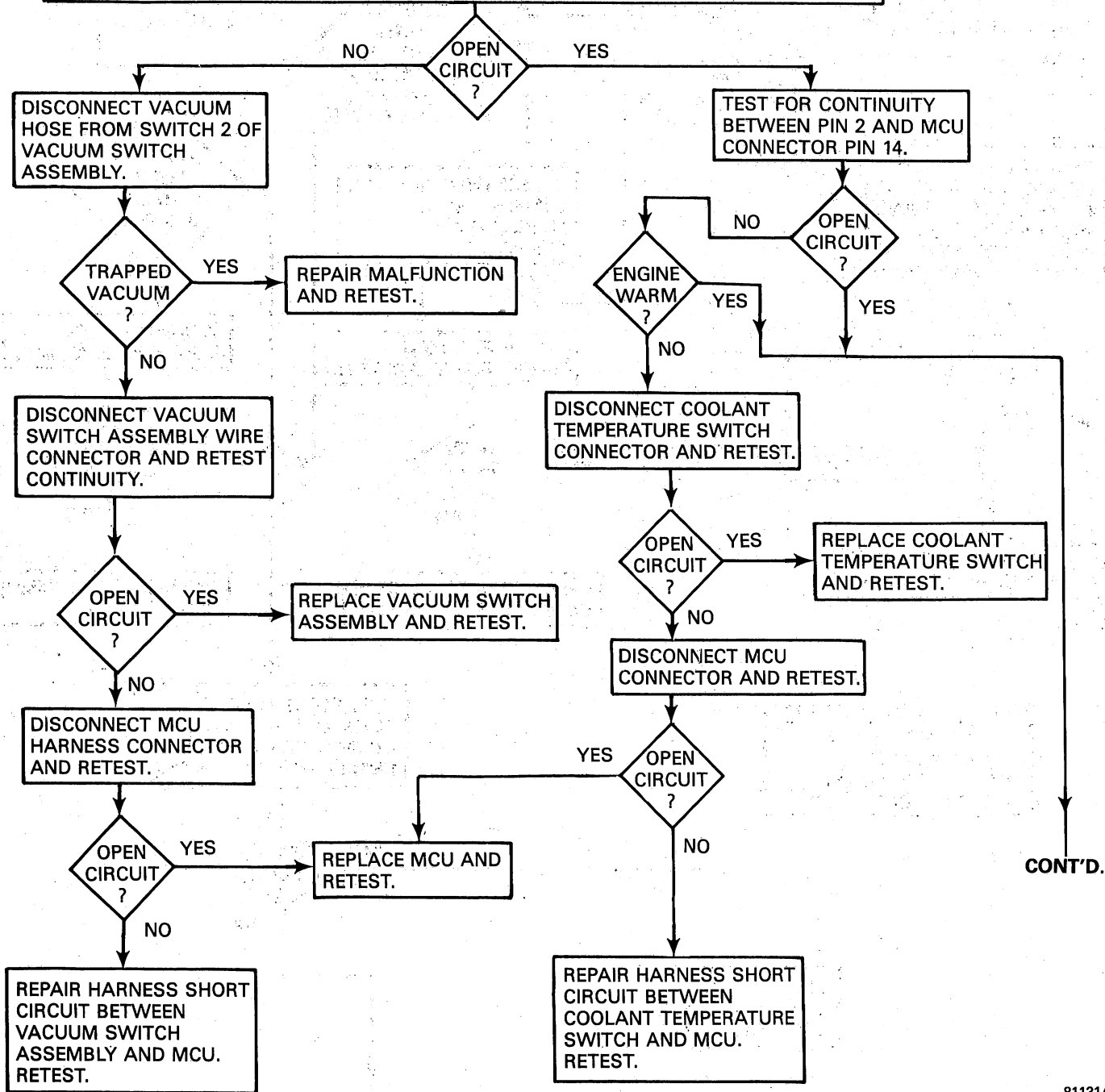

CONTINUED FROM PREVIOUS PAGE

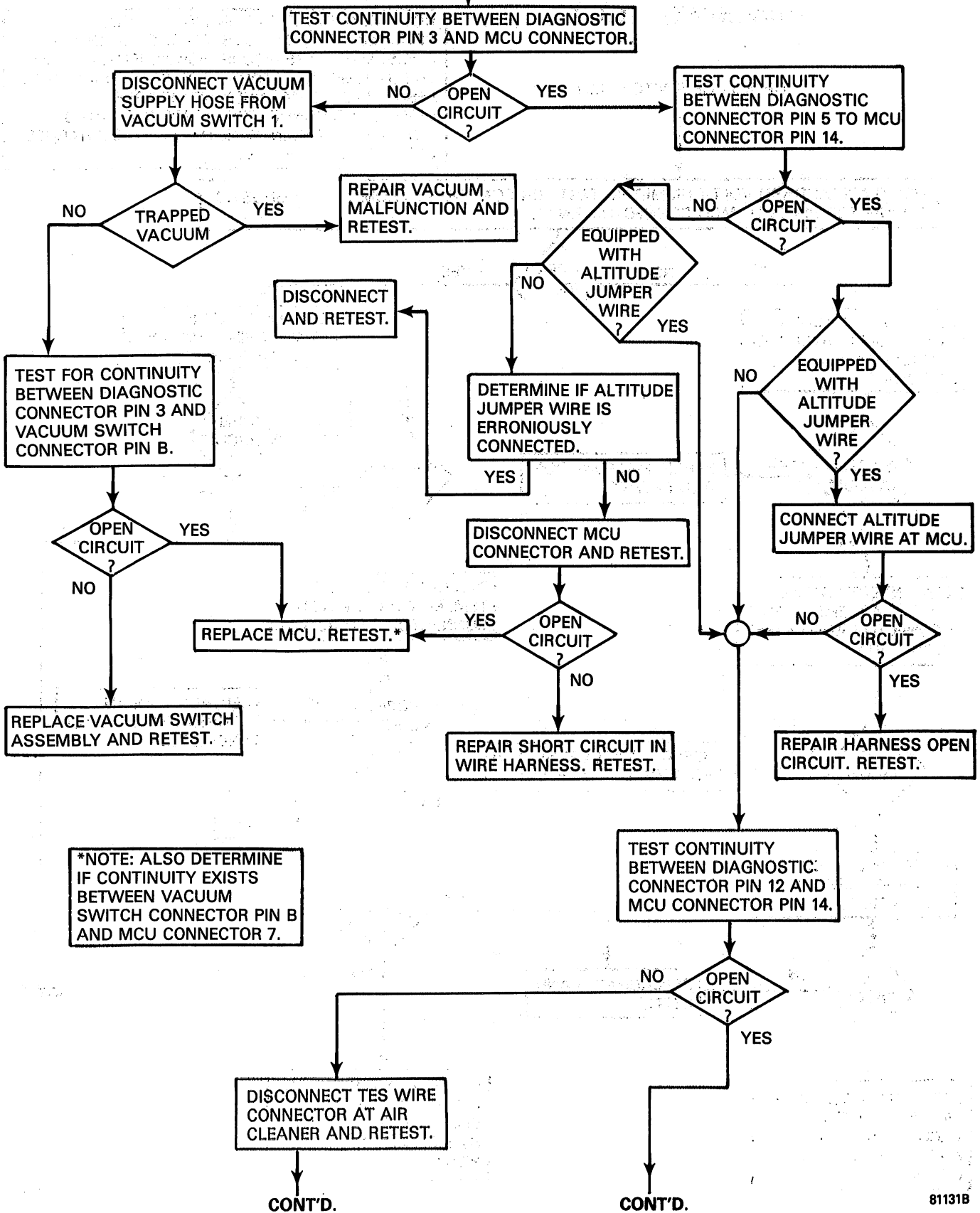

*NOTE: ALSO DETERMINE IF CONTINUITY EXISTS BETWEEN VACUUM SWITCH CONNECTOR PIN B AND MCU CONNECTOR 7.

CONTINUED FROM PREVIOUS PAGE

CONTINUED FROM PREVIOUS PAGE

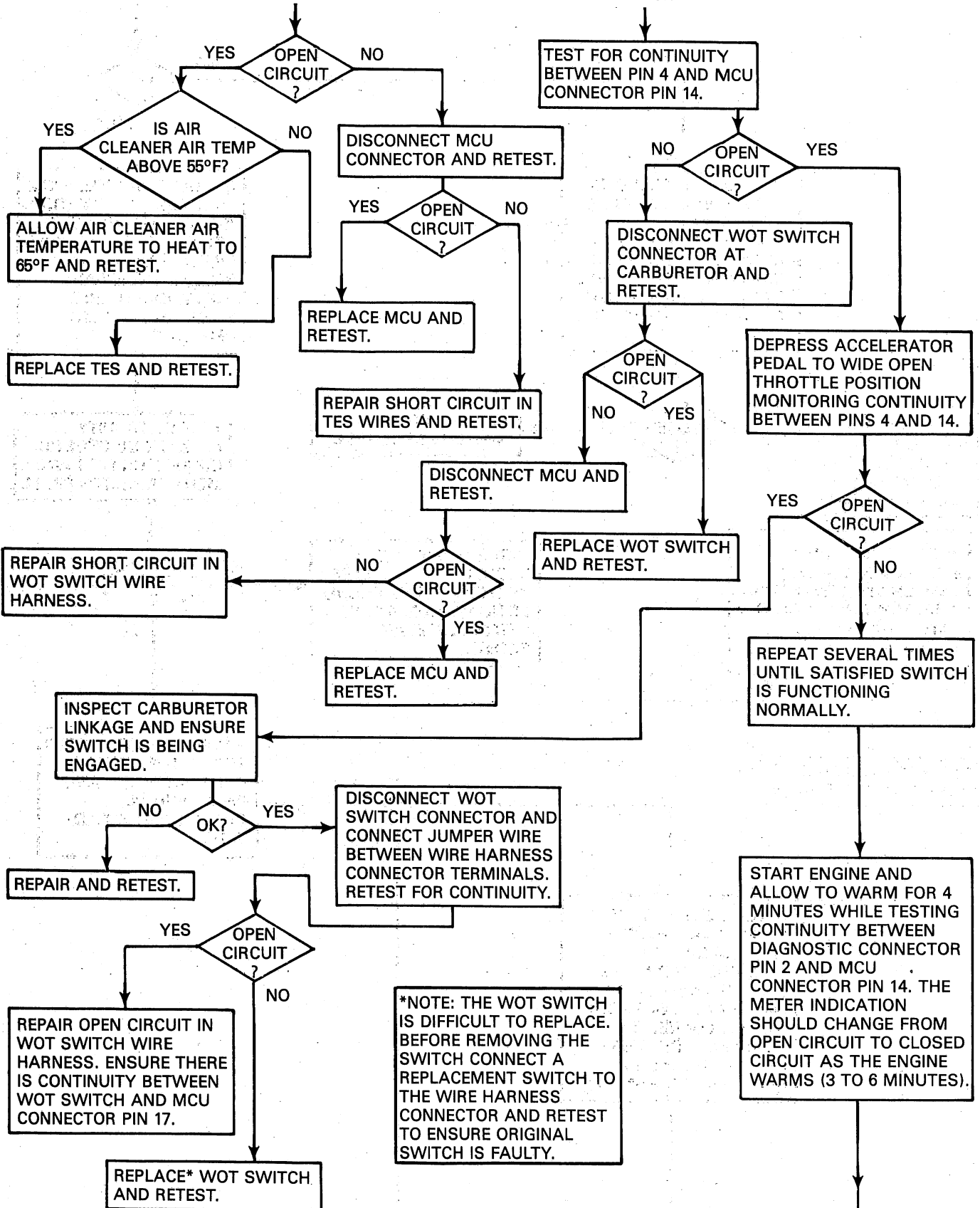

*NOTE: THE WOT SWITCH IS DIFFICULT TO REPLACE. BEFORE REMOVING THE SWITCH CONNECT A REPLACEMENT SWITCH TO THE WIRE HARNESS CONNECTOR AND RETEST TO ENSURE ORIGINAL SWITCH IS FAULTY.

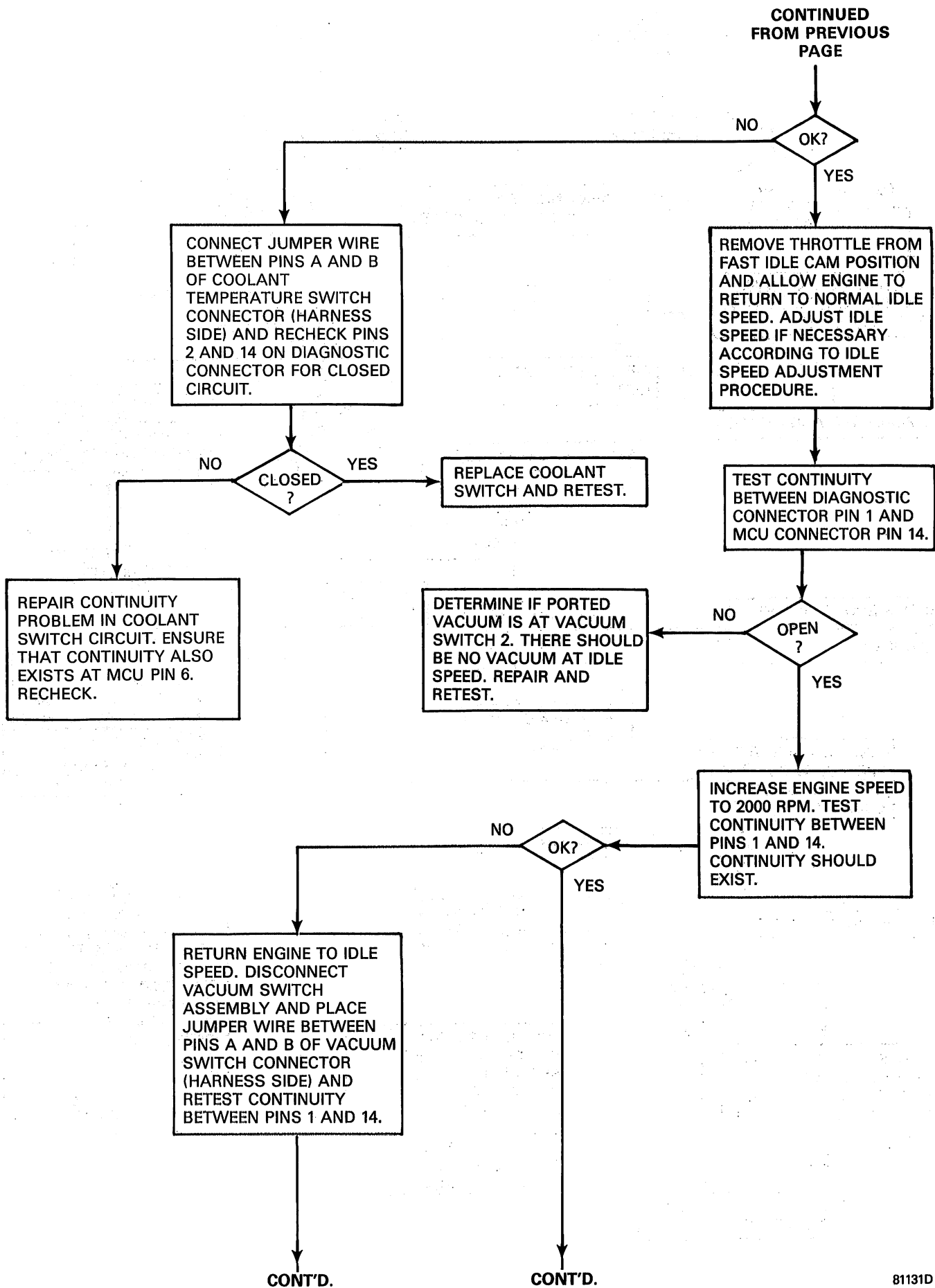

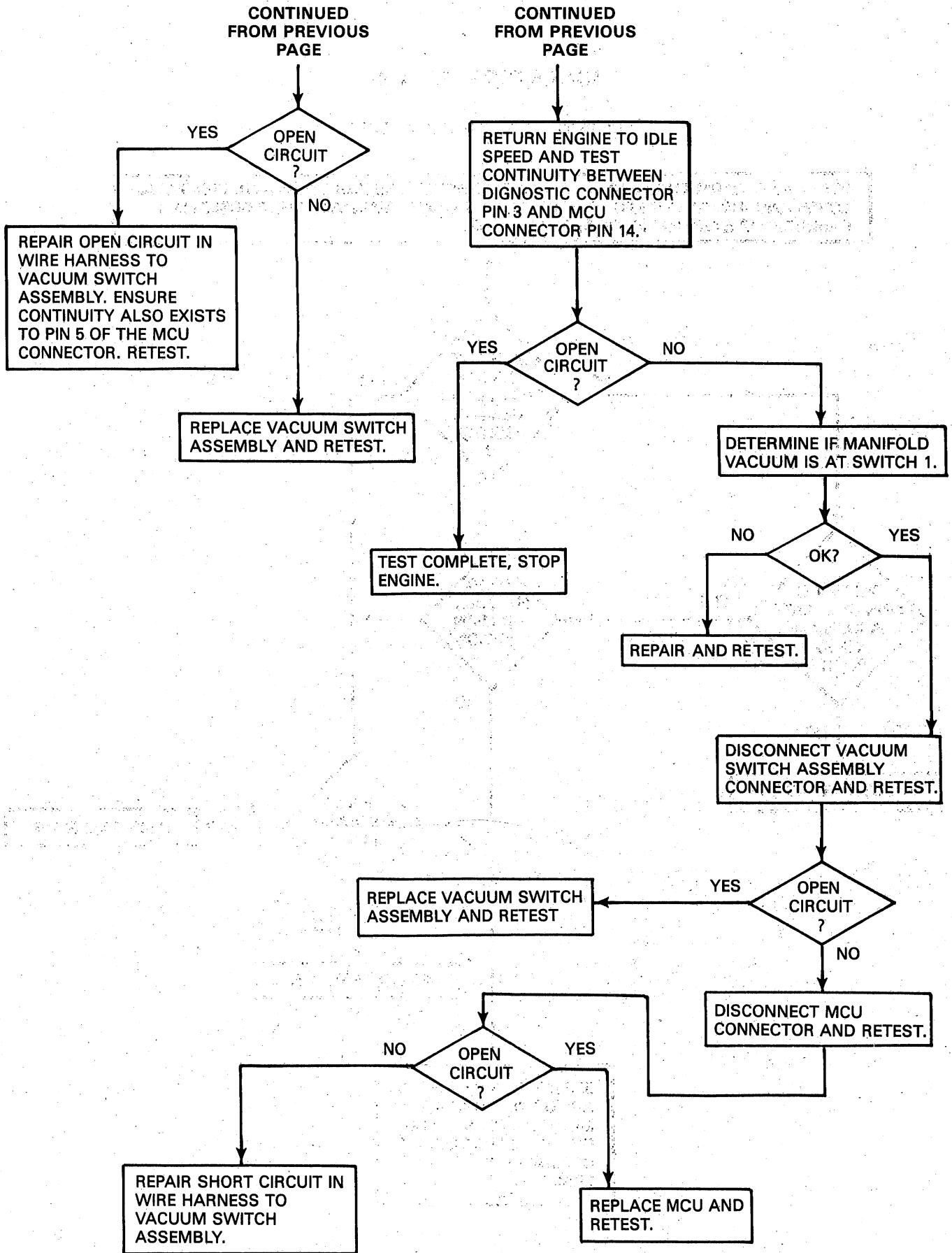

DIAGNOSTIC TEST 3

CLOSED LOOP OPERATIONAL TEST

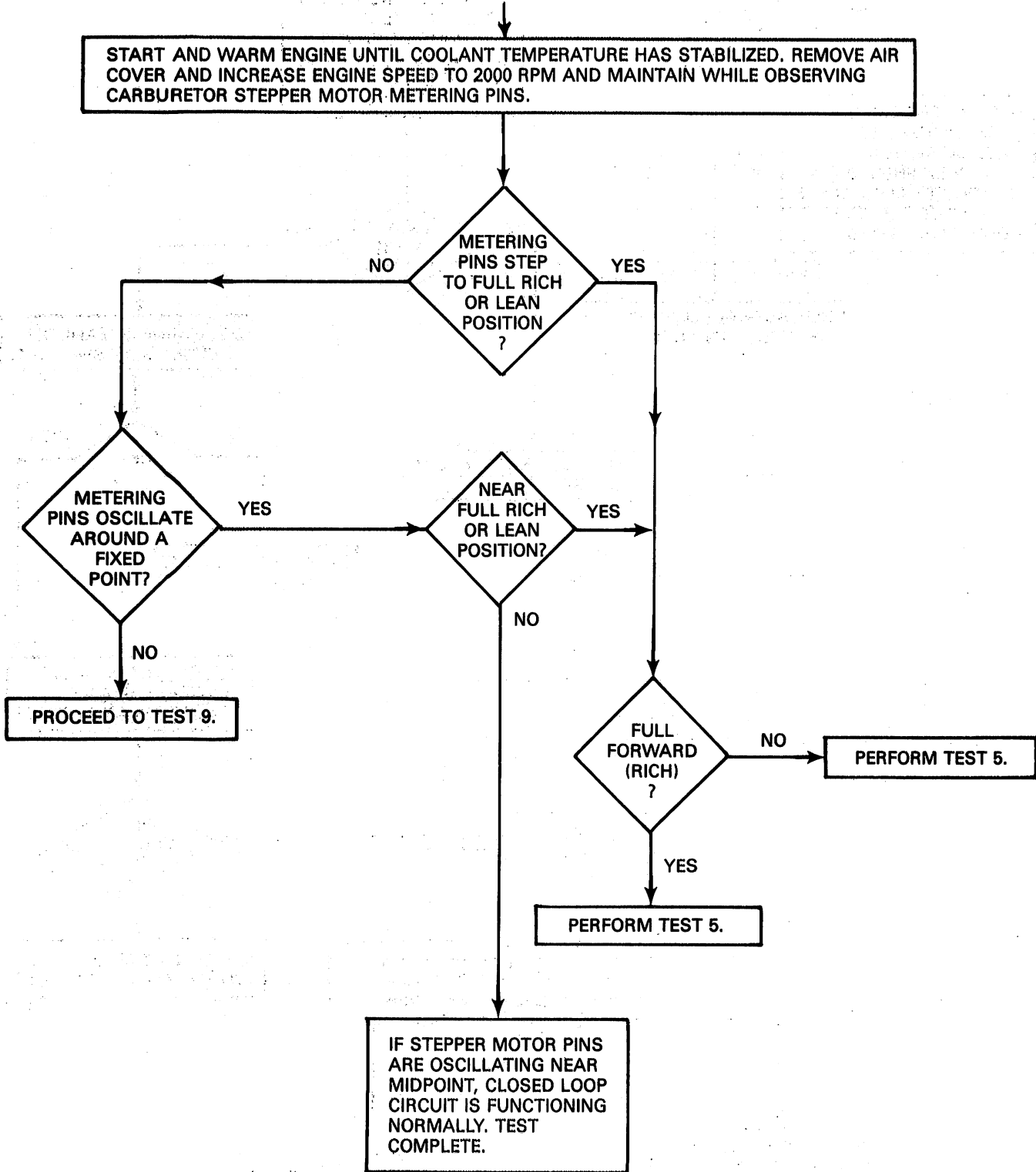

DIAGNOSTIC TEST 4

ELECTRONIC IGNITION RETARD TEST

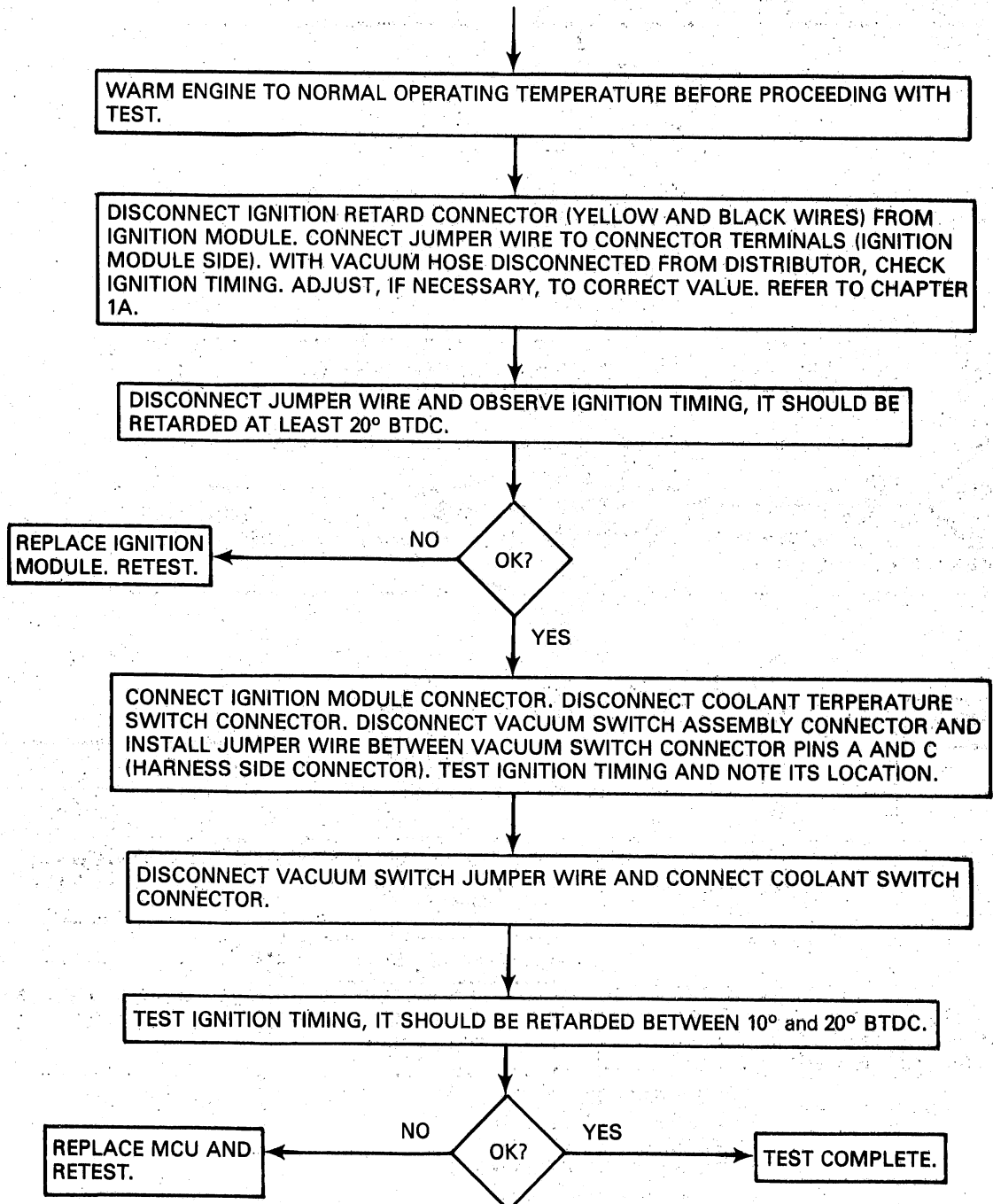

DIAGNOSTIC TEST 5

OXYGEN SENSOR AND
CLOSED-LOOP TEST

WITH ENGINE OFF, REMOVE AIR CLEANER AND PLUG ALL VACUUM HOSES.

TURN IGNITION SWITCH ON FOR 4 SECONDS, THEN TURN OFF.

DISCONNECT MCU CONNECTOR. START ENGINE AND OPERATE UNTIL TEMPERATURE GAUGE POINTER IS AT MIDRANGE (OR 4 MINUTES).

CONNECT POSITIVE PROBE OF DIGITAL VOLTMETER (OR VOLTMETER WITH GREATER THAN 1 MEGOHM INPUT IMPEDANCE) TO PIN 3 AT HARNESS SIDE OF MCU CONNECTOR AND NEGATIVE PROBE TO PIN 14 (GROUND).

INCREASE ENGINE SPEED TO APPROXIMATELY 1200 RPM AND MAINTAIN. CLOSE CHOKE VALVE AND OBSERVE VOLTMETER. (CLOSE VALVE FOR AT LEAST 15 SECONDS BUT DO NOT EXCEED 30 SECONDS.)

GREATER THAN 0.6 VOLTS ?

YES

NO

TURN ENGINE OFF AND CONNECT MCU CONNECTOR. START ENGINE AND OPERATE FOR A MINIMUM OF 1 MINUTE.

INCREASE ENGINE SPEED TO MORE THAN 1200 RPM. HOLD THE CHOKE VALVE CLOSED FOR AT LEAST 20 SECONDS AND TURN IGNITION OFF WITH VALVE CLOSED.

CONT'D.

TURN ENGINE OFF. DISCONNECT AND PLUG AIR HOSE CONNECTED TO EXHAUST AIR INJECTION MANIFOLD.

START ENGINE AND OPERATE FOR 1 MINUTE. TEST OXYGEN SENSOR VOLTAGE (PIN 3 OF MCU CONNECTOR).

CONT'D.

CONTINUED FROM PREVIOUS PAGE

OBSERVE STEPPER MOTOR METERING PINS. PINS SHOULD BE IN LEAN POSITION (TOWARD REAR OF ENGINE).

POSITION OK ?

YES

NO

STEPPER MOTOR PINS ARE AT MIDWAY TO FULL RICH POSITION. REPLACE MCU AND RETEST STEPPER MOTOR PIN POSITION.

CONTINUED FROM PREVIOUS PAGE

GREATER THAN 0.6 VOLTS ?

YES

NO

PROCEED WITH TEST 6

DISCONNECT OXYGEN SENSOR CONNECTOR AND TEST VOLTAGE AT OXYGEN SENSOR.

GREATER THAN 0.6 VOLTS ?

YES

NO

REPAIR WIRE HARNESS BETWEEN O₂ SENSOR CONNECTOR AND MCU CONNECTOR.

INSPECT FOR LARGE AIR LEAK INTO MANIFOLD VACUUM. IF OK, REPLACE OXYGEN SENSOR.

START ENGINE AND OPERATE FOR 40 SECONDS. INCREASE ENGINE SPEED TO MORE THAN 1000 RPM AND LOAD ENGINE (E.G., AC ON). OBSERVE STEPPER MOTOR PIN MOVEMENT. PINS SHOULD MOVE FORE AND AFT OF A FIXED POINT.

RESTRICT AIR HOSE CONNECTED TO EXHAUST AIR INJECTION MANIFOLD AND OBSERVE AVERAGE POSITION OF STEPPER MOTOR PINS.

AVERAGE POSITION CHANGED ?

YES

NO

PROCEED TO TEST 6.

PROCEED TO BASIC ENGINE TEST.

BASIC ENGINE TEST

IF THE RESULTS OF DIAGNOSTIC TESTS 1 THROUGH 5 INDICATE THAT THE CEC SYSTEM IS FUNCTIONING NORMALLY AND ENGINE PERFORMANCE REMAINS INADEQUATE, PERFORM THE FOLLOWING TEST.

DETERMINE WHICH DIRECTION, RICH OR LEAN, THAT STEPPER MOTOR METERING PINS CONSISTENTLY MOVE TOWARD.

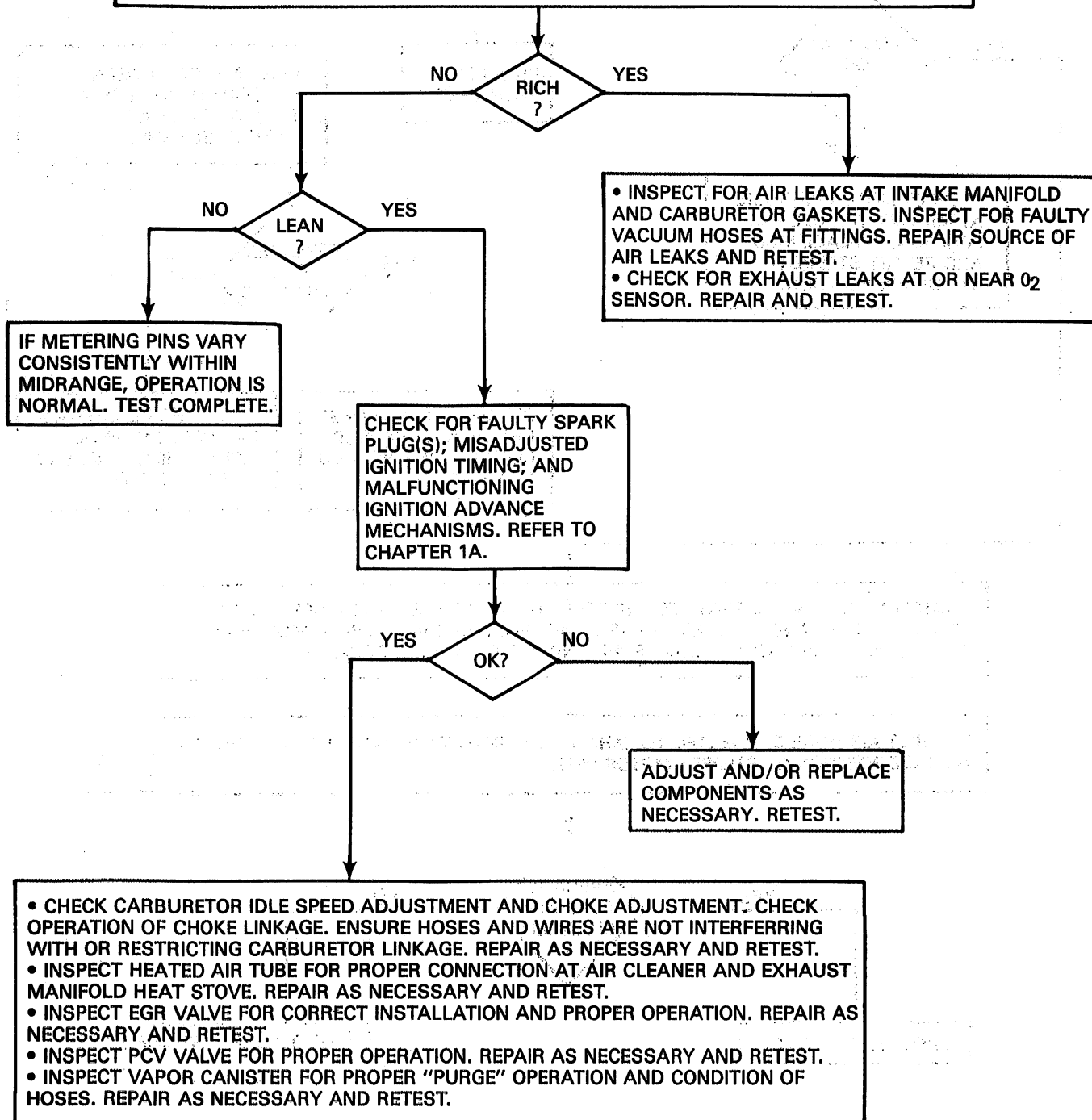

DIAGNOSTIC TEST 6

AIR INJECTION SYSTEM TEST

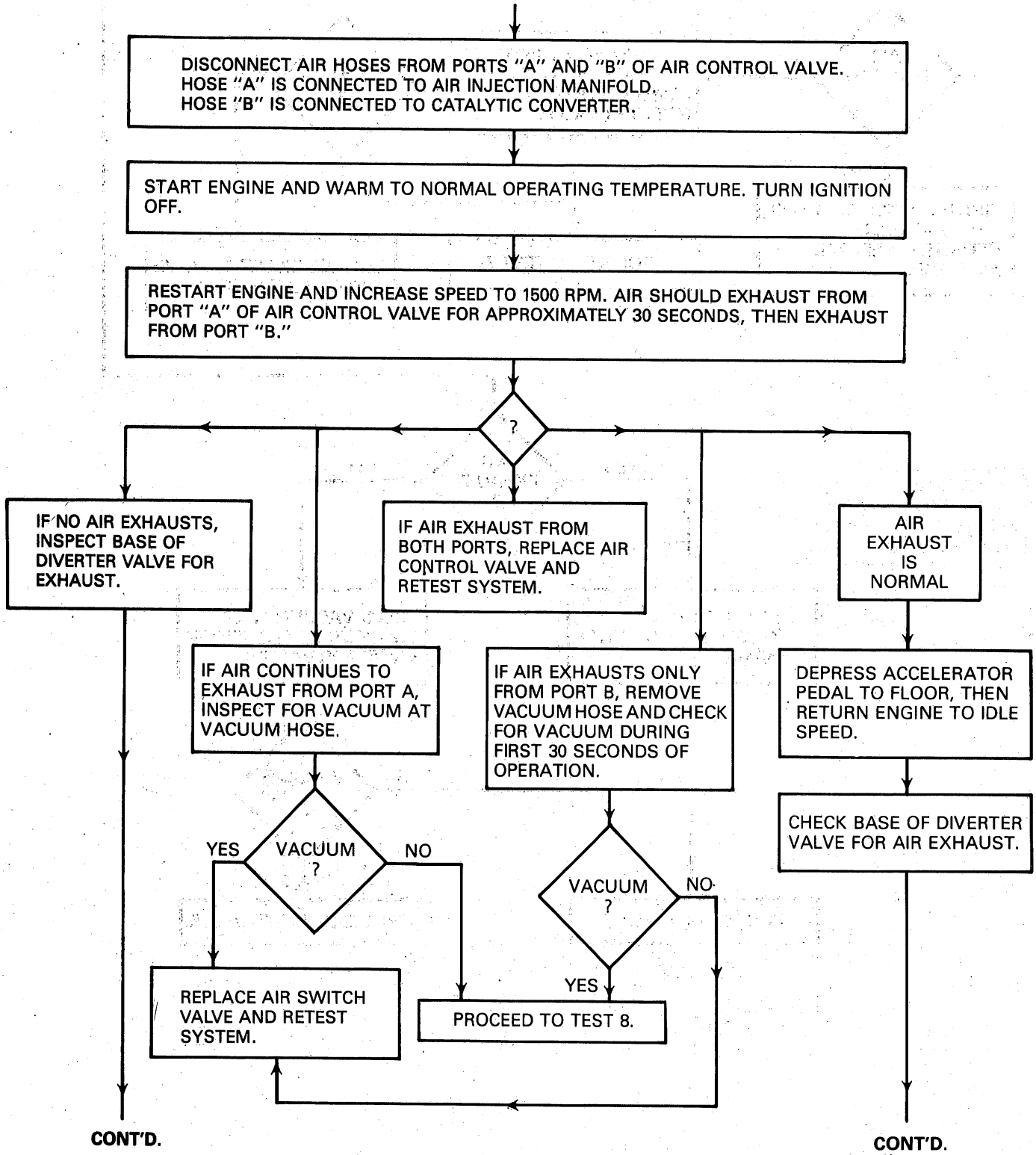

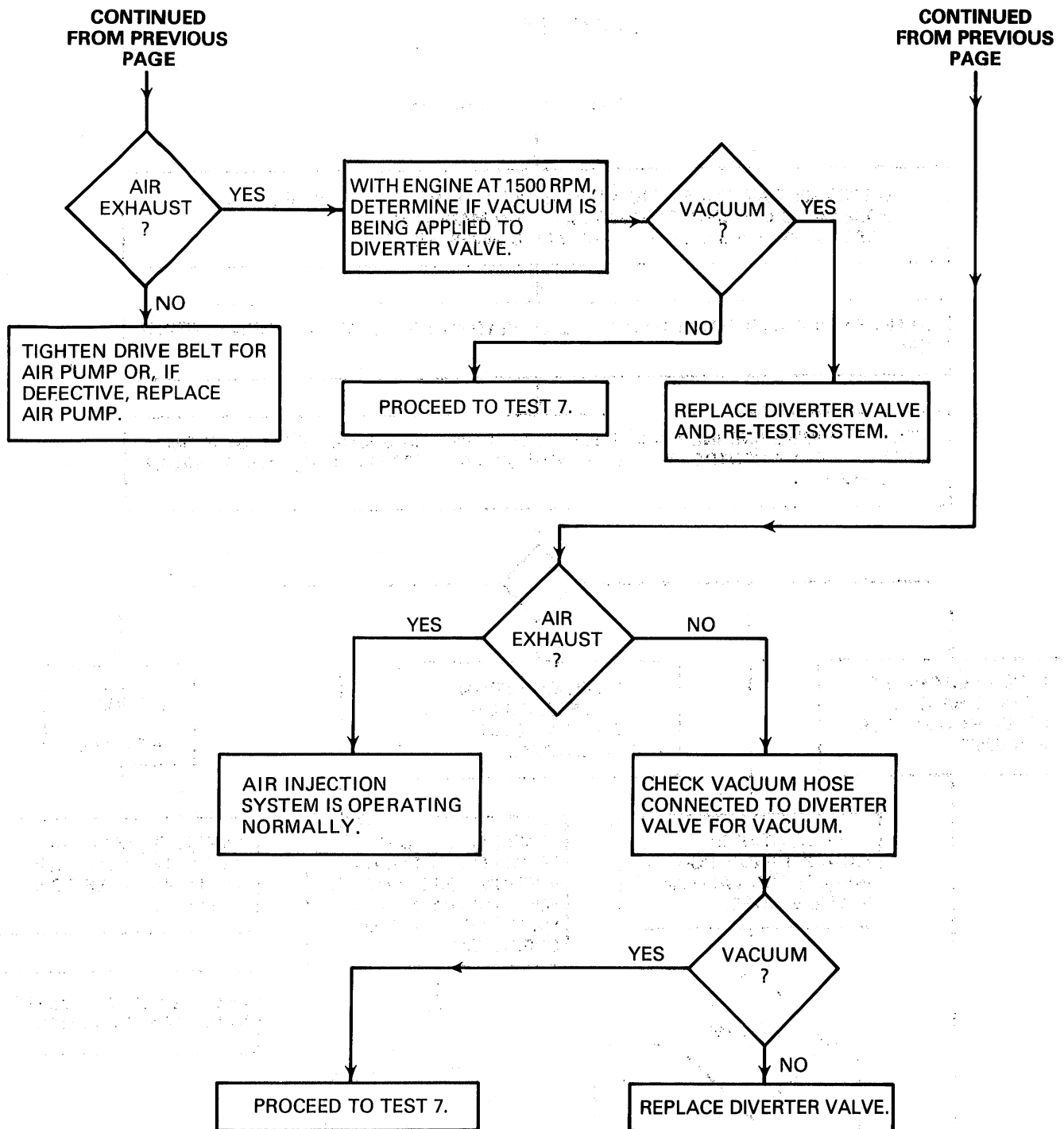

NOTE: WHEN APPLICABLE, DIAGNOSTIC CONNECTOR TERMINALS CAN BE USED AS TEST POINTS INSTEAD OF MCU CONNECTOR TERMINALS.

DIAGNOSTIC TEST 7

DIVERT SOLENOID TEST

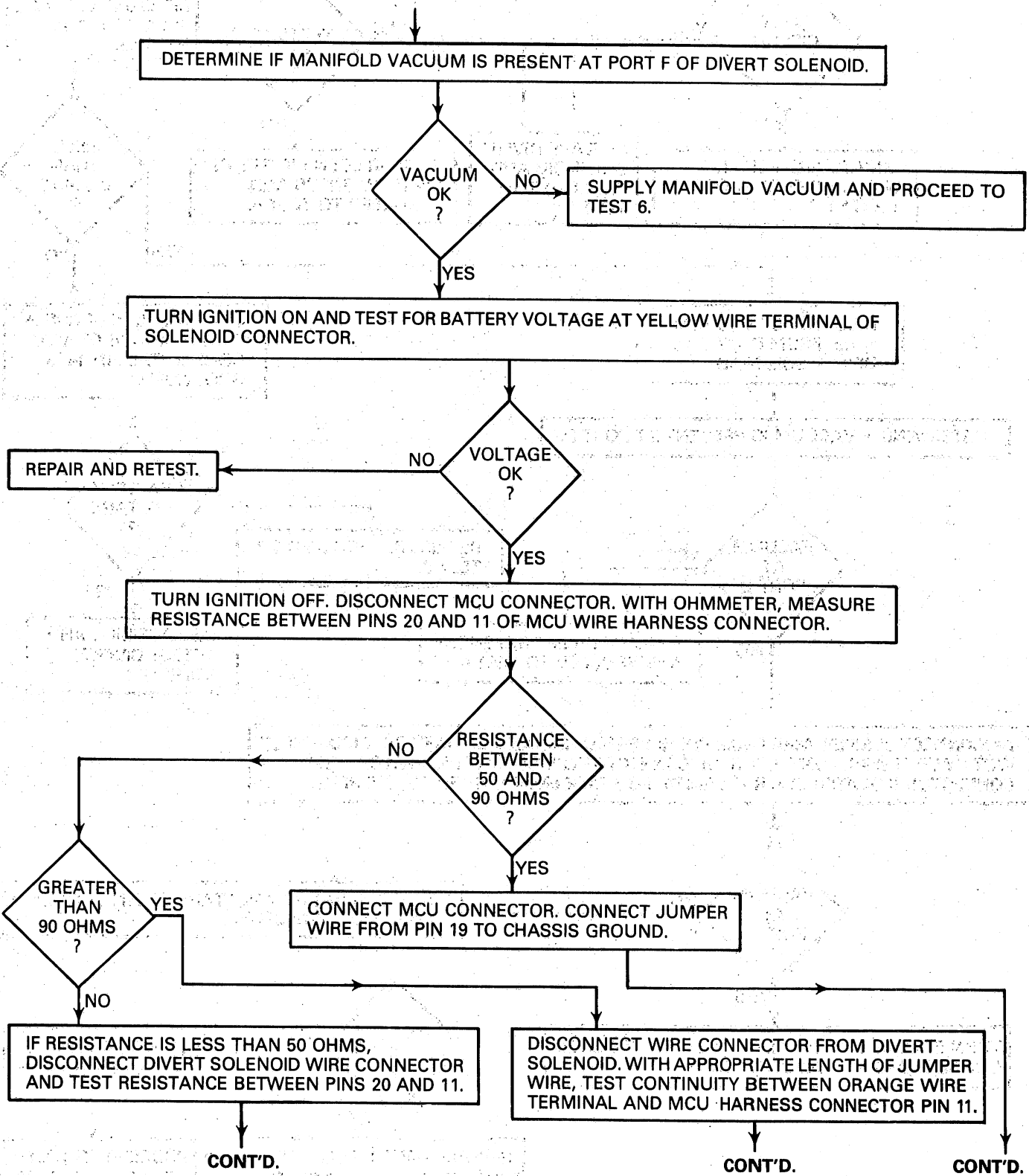

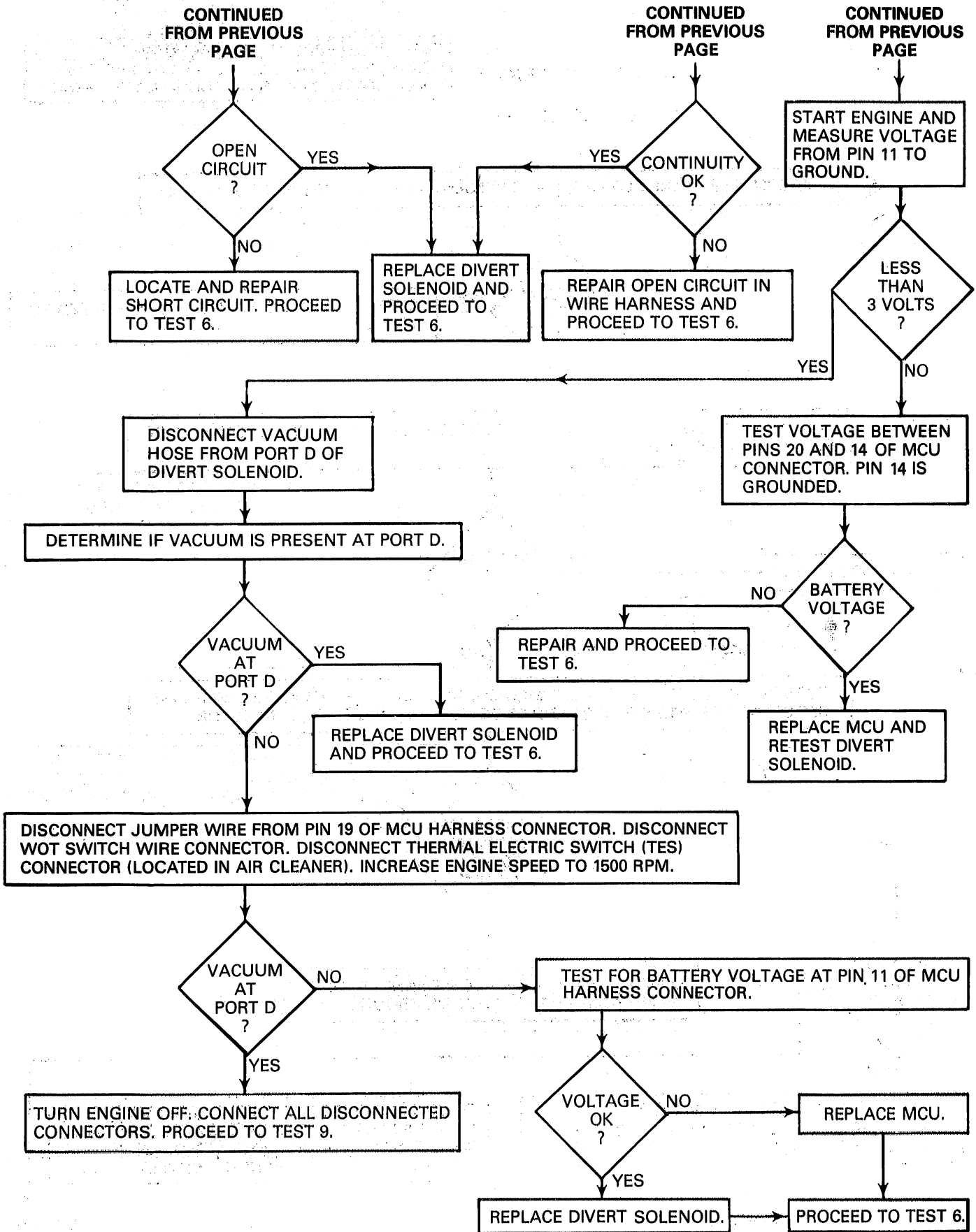

DIAGNOSTIC TEST 8

NOTE: WHEN APPLICABLE, DIAGNOSTIC CONNECTOR TERMINALS CAN BE USED AS TEST POINTS INSTEAD OF MCU CONNECTOR TERMINALS.

UPSTREAM SOLENOID TEST

DETERMINE IF MANIFOLD VACUUM IS SUPPLIED TO PORT F OF SOLENOID.

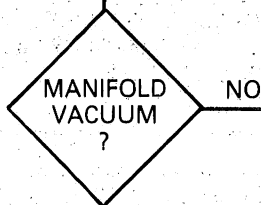

REPAIR AND PROCEED TO TEST 6.

TURN IGNITION ON. WITH VOLTMETER, TEST FOR BATTERY VOLTAGE (12V) AT SOLENOID (YELLOW WIRE TERMINAL).

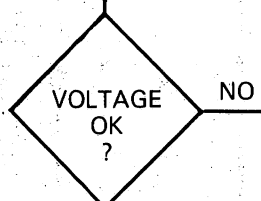

SUPPLY BATTERY VOLTAGE TO SOLENOID WITH JUMPER WIRE AND PROCEED TO TEST 6.

TURN IGNITION OFF. DISCONNECT MCU HARNESS CONNECTOR. WITH VOLT-OHMMETER, MEASURE RESISTANCE BETWEEN PIN 12 AND PIN 20 OF WIRE HARNESS.

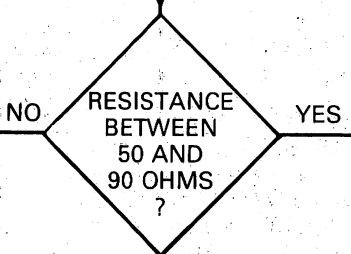

CONNECT MCU HARNESS CONNECTOR AND DISCONNECT VACUUM HOSE AT PORT D OF SOLENOID. START AND WARM ENGINE FOR AT LEAST 4 MINUTES.



DISCONNECT WIRE CONNECTOR FROM SOLENOID. USING LONG JUMPER WIRE, TEST CONTINUITY BETWEEN SOLENOID (PINK WIRE) AND PIN 12 OF MCU HARNESS CONNECTOR.

DISCONNECT SOLENOID WIRE CONNECTOR AND RE-MEASURE RESISTANCE.

STOP ENGINE AND DISCONNECT WOT AND THERMAL ELECTRIC SWITCH CONNECTORS.

CONT'D.

CONT'D.

CONT'D.

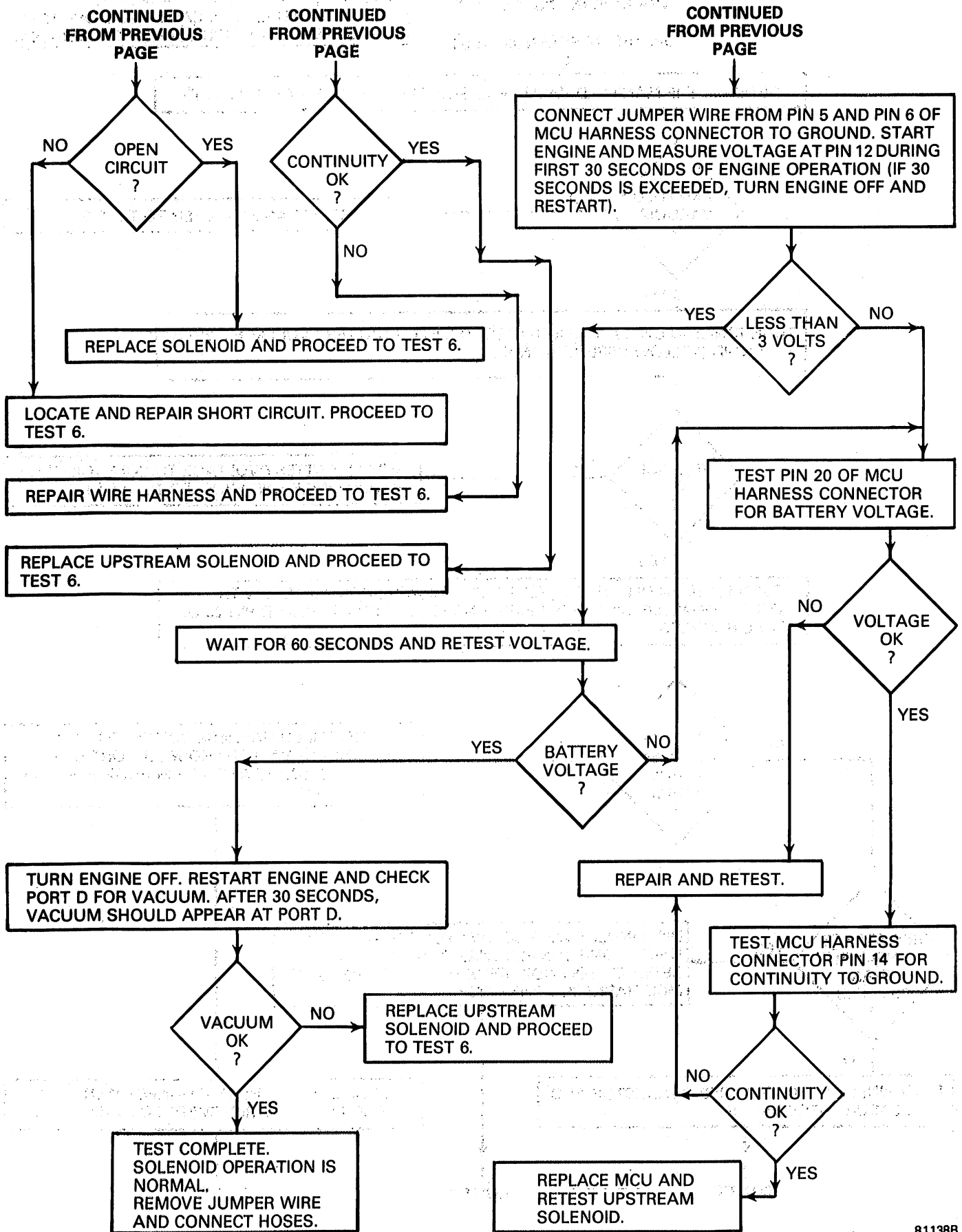

DIAGNOSTIC TEST 9

NOTE: TEST MUST BE PERFORMED WITH ENGINE AT NORMAL OPERATING TEMPERATURE AND AFTER CEC SYSTEM DIAGNOSTIC TESTS ARE COMPLETED.

IDLE SPEED CONTROL SYSTEM TEST

TURN OFF ALL ACCESSORIES INCLUDING REAR WINDOW DEFOGGER, HEADLAMPS, AND A/C. ADJUST ENGINE IDLE SPEED IF NECESSARY. REFER TO CHAPTER 1A.

TURN ENGINE OFF AND RESTART WHILE MONITORING SOLE-VAC THROTTLE POSITION DURING FIRST 60 SECONDS OF ENGINE OPERATION. SOLE-VAC THROTTLE POSITIONER SHOULD BE FULLY EXTENDED DURING FIRST 15 SECONDS AND THEN SHOULD MOVE TO INTERMEDIATE POSITION FOR NEXT 45 SECONDS, THEN DISENGAGE.

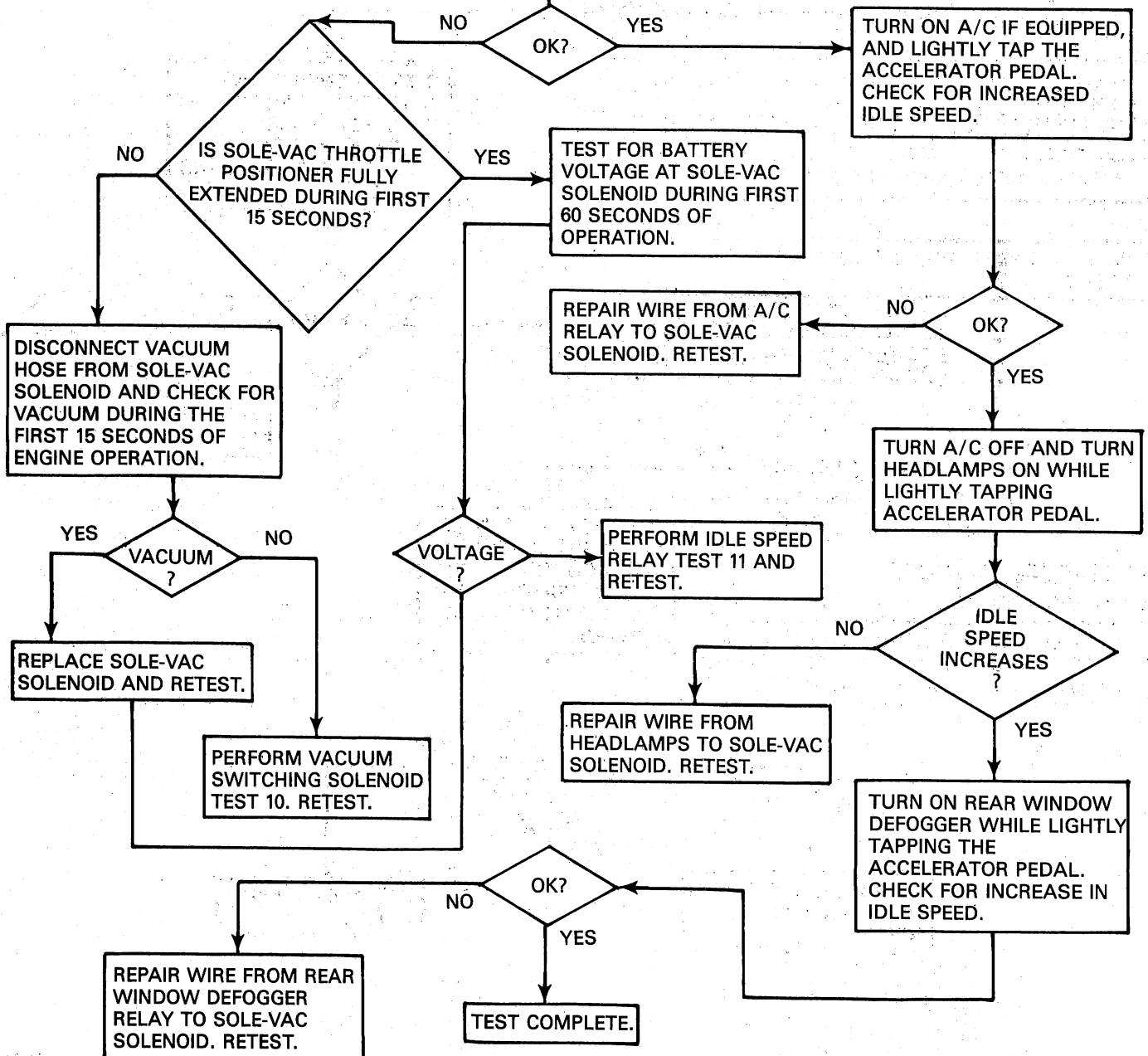

DIAGNOSTIC TEST 10

SOLE-VAC VACUUM SWITCHING SOLENOID TEST

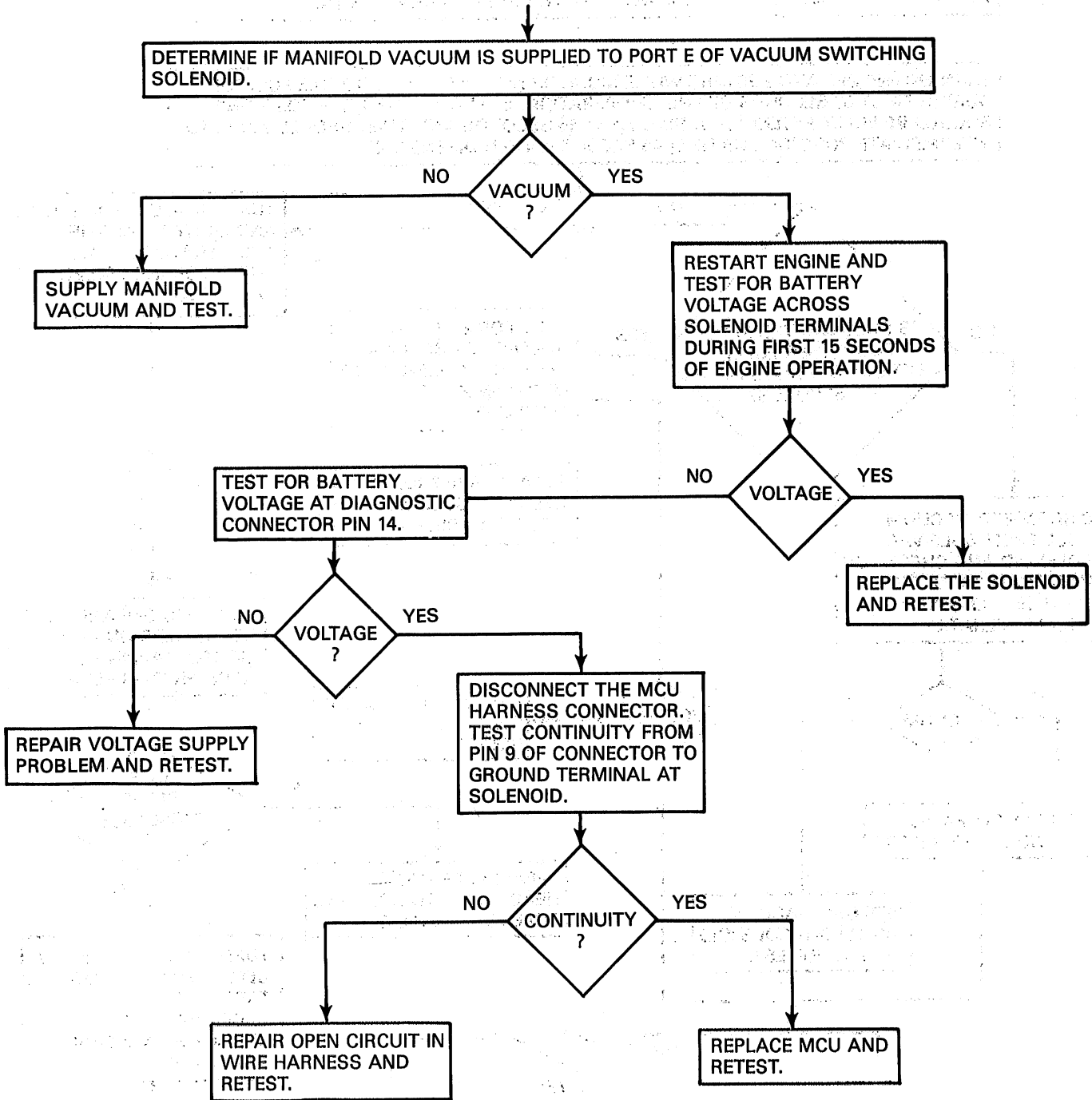

DIAGNOSTIC TEST 11

SOLE-VAC IDLE SPEED RELAY TEST

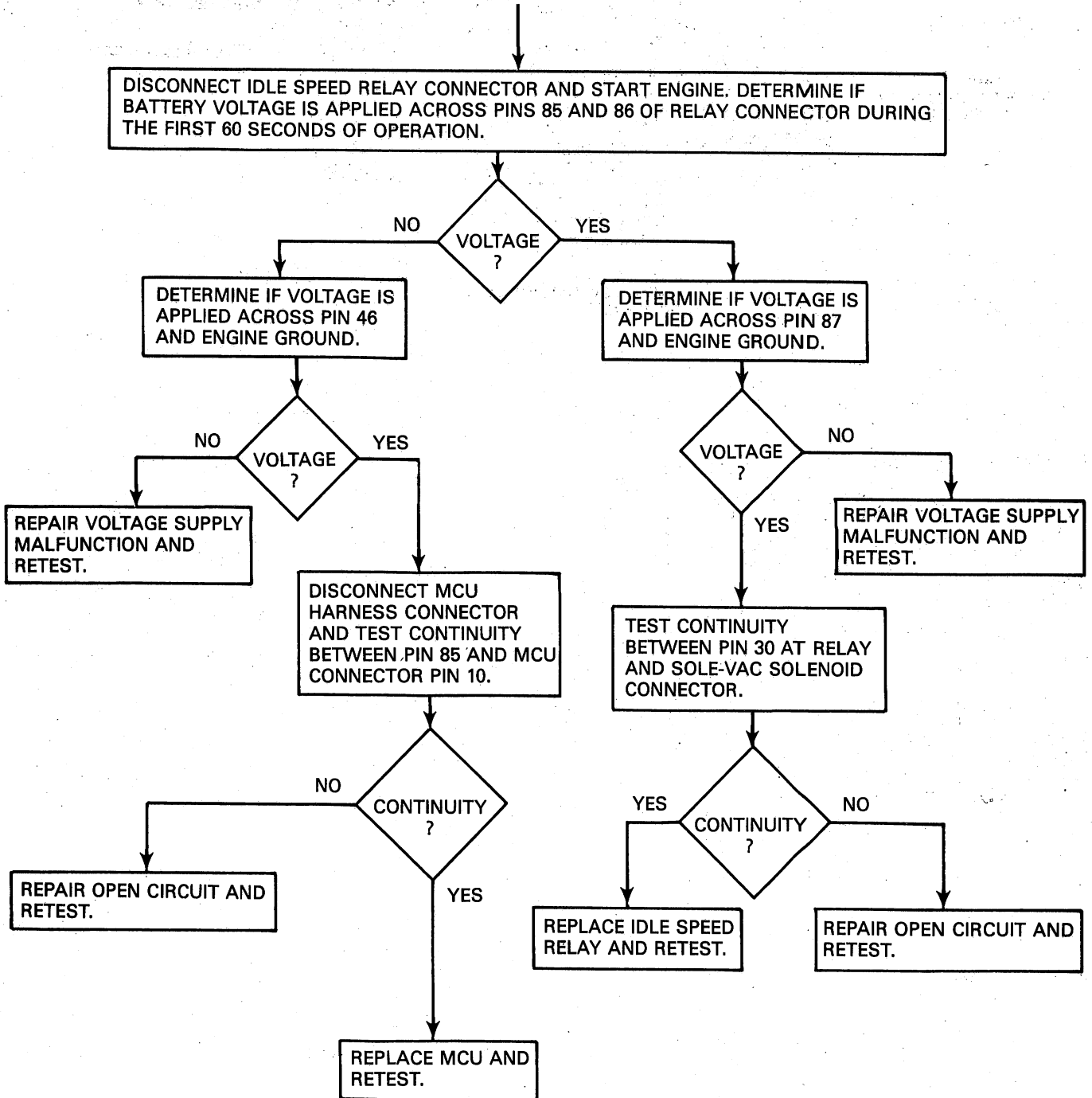

Tools



**J-1137
BENDING TOOL**



**J-10174-01
MAIN JET REMOVER
AND INSTALLER**

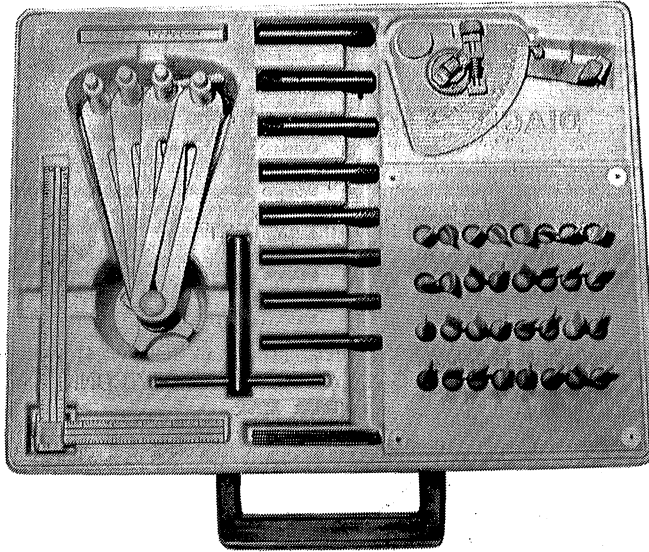

**J-9789-C
UNIVERSAL CARBURETOR
GAUGE SET**

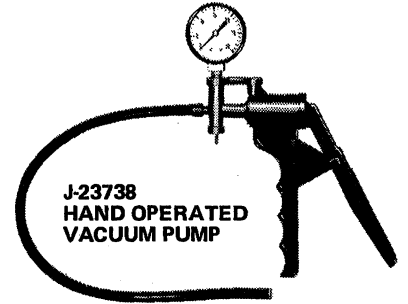

**J-23738
HAND OPERATED
VACUUM PUMP**