

WIRING DIAGRAMS

INDEX

	Page		Page
Accessory Diagrams—CJ-Cherokee-Wagoneer-Truck	W-7	Wiring Diagrams—Cherokee-Wagoneer-Truck	W-5
Engine Compartment—4-Cylinder—CJ	W-2	Wiring Diagram—CJ Models	W-3
Engine Compartment—6-Cylinder—Cherokee-Wagoneer-Truck	W-4	Wiring Diagrams—Trailer Towing Package	W-6
Radio Power Amp	W-8		

Wiring Diagram CJ Models 4-CYLINDER

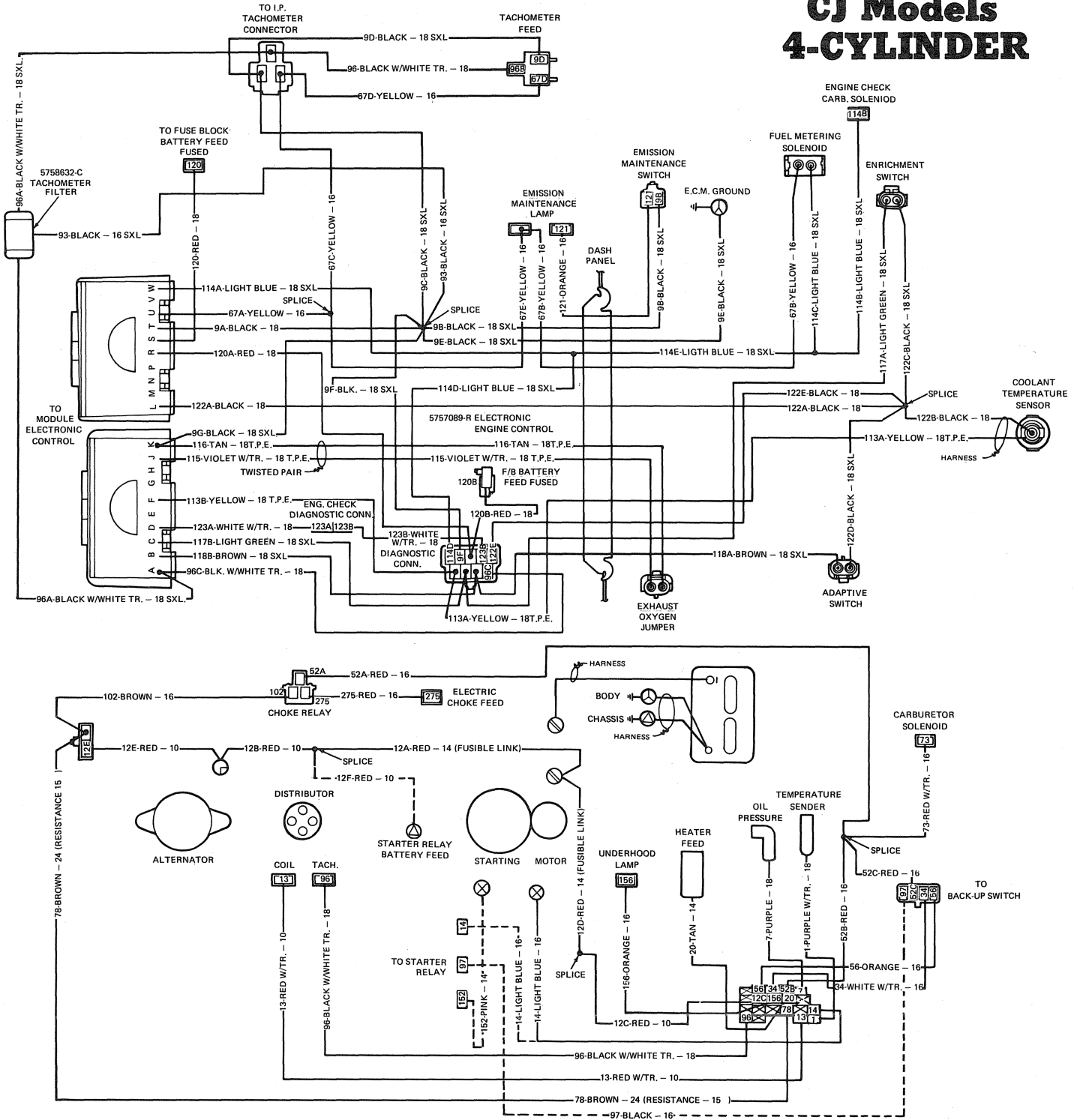

5757084-R 4 CYL. ENG. (AUTO. TRANS.)
 5758597-R 4 CYL. ENG. (MANUAL TRANS.)
 CIRCUIT SYMM. MANUAL TRANS. ——— AUTO. TRANS. - - - - -

Wiring Diagram
CJ Models

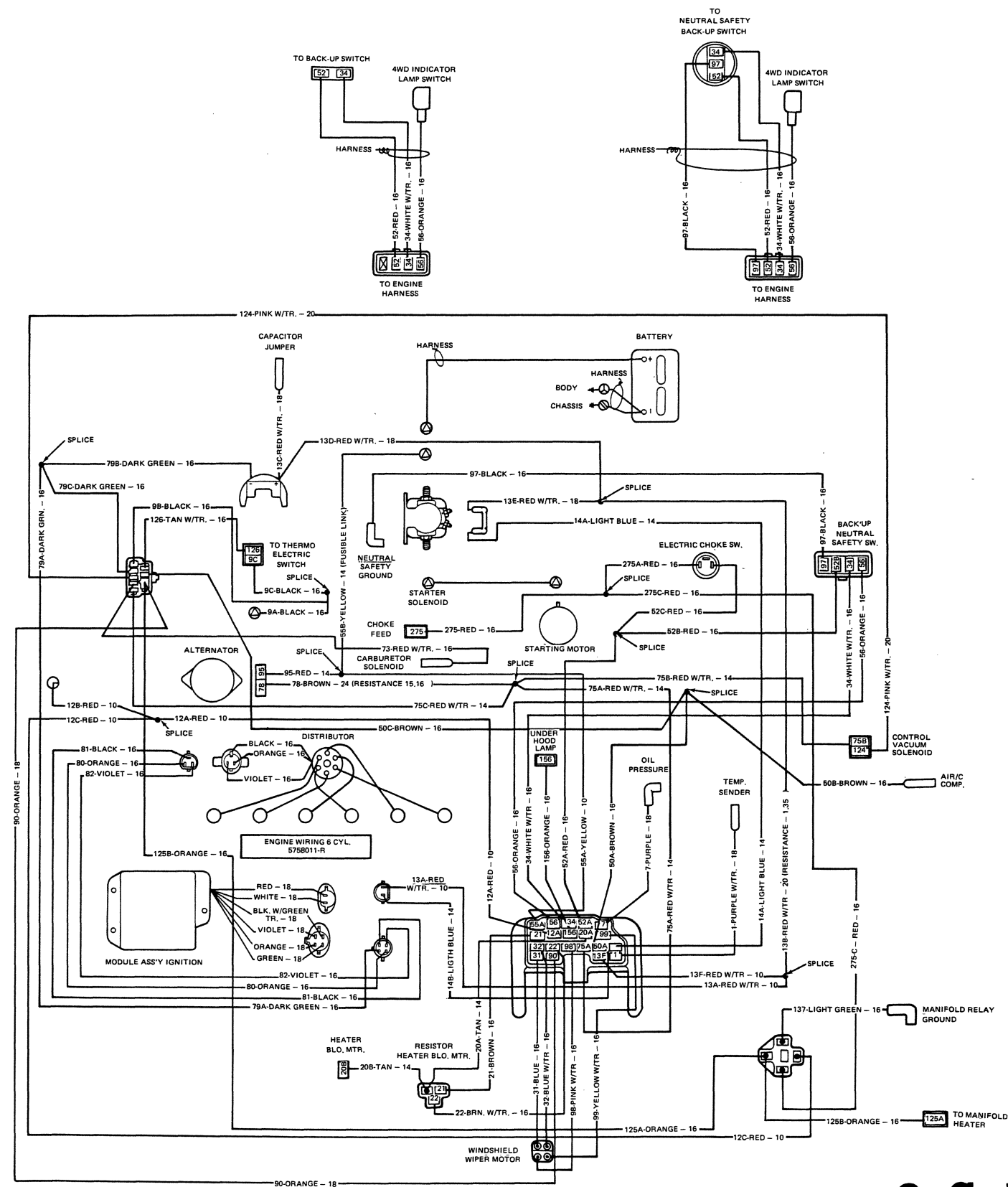

6-Cyl.
Cherokee - Wagoneer - Truck
Wiring Diagram

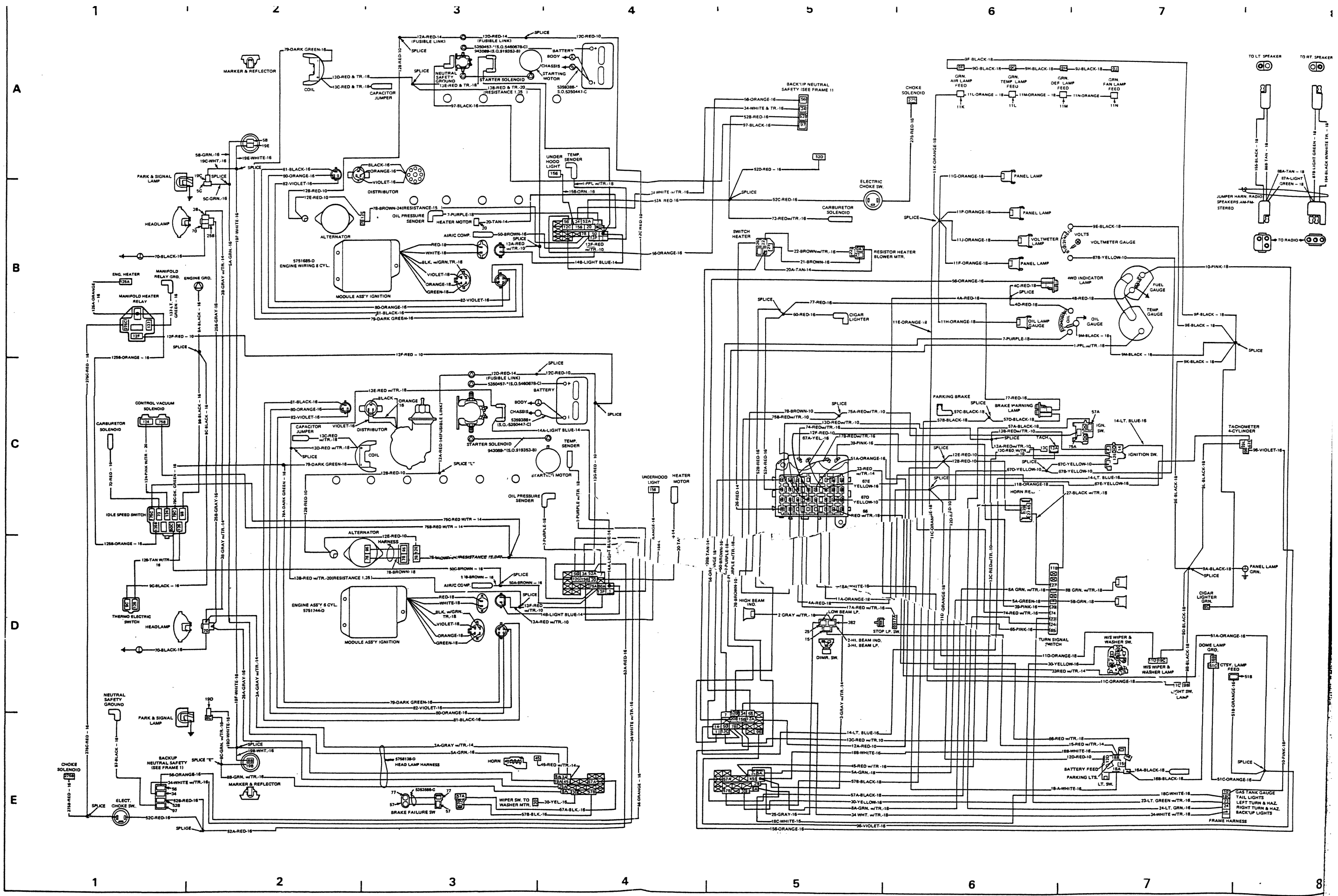

A

B

C

D

E

1

2

3

4

5

6

7

1

2

3

4

5

6

7

8

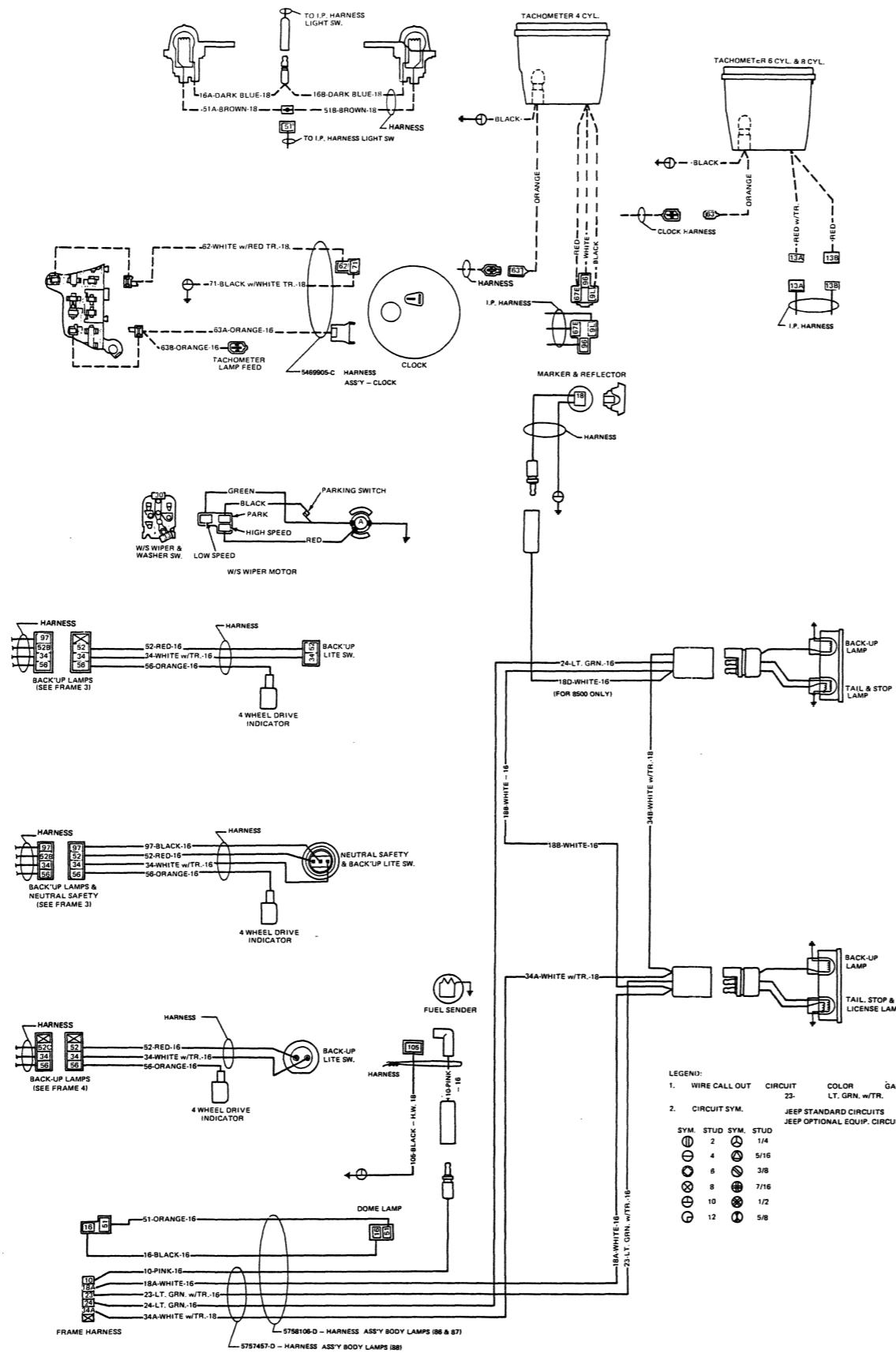

LEGEND:

- WIRE CALL OUT: CIRCUT, COLOR, GAUGE
LT. GRN. w/TR. -16
- CIRCUIT SYM. JEEP STANDARD CIRCUITS, JEEP OPTIONAL EQUIP. CIRCUITS

SYM.	STUD SYM.	STUD
⊕	⊕	1/4
⊖	⊖	4
⊗	⊗	5/16
⊙	⊙	3/8
⊚	⊚	7/16
⊛	⊛	1/2
⊜	⊜	5/8

Wiring Diagram CJ Models

A
B
C
D
E

Component Grid Locator

CJ Models

NOMENCLATURE	LOCATION
Accessory Feed	C-7
Air Conditioner Compressor, 8-Cylinder	B-3
Alternator, 8-Cylinder	B-2
Alternator, 6-Cylinder	D-3
Back-up Lamp, Right Side	C-11
Back-up Lamp, Left Side	D-11
Back-up Light Switch	
Manual Transmission	C-9, D-9
Back-up Light Switch	
Automatic Transmission	D-9
Battery, 8-Cylinder	A-4
Battery, 6-Cylinder	C-4
Body Ground, 8-Cylinder	A-4
Body Ground, 6-Cylinder	C-4
Brake Failure Switch	E-3
Brake Warning Lamp	C-6
Capacitor Jumper, 8-Cylinder	A-3
Capacitor Jumper, 6-Cylinder	C-2
Chassis Ground, 8-Cylinder	A-4
Chassis Ground, 6-Cylinder	C-4
Cigar Lighter Feed	D-7
Coil, 8-Cylinder	A-2
Coil, 6-Cylinder	C-3
Dimmer Switch	D-5
Distributor, 8-Cylinder	A-3
Distributor, 6-Cylinder	C-3
Electric Choke	B-5, E-1
Fuel Gauge	B-7
Fuel Sender	D-10
Ground Air Lamp Feed	A-6
Ground Defogger Lamp Feed	A-6
Ground Fan Lamp Feed	A-7
Ground Temperature Lamp Feed	A-6
Headlamp, Right Side	B-1
Headlamp, Left Side	D-1
Heater Motor, 8-Cylinder	B-3
Heater Motor, 6-Cylinder	D-3
Heater Switch	B-5
High Beam Indicator	D-5
Horn	E-3
Horn Relay	C-6
Ignition Switch	C-7
Left Turn Indicator & Hazard Lamp	E-7
Low Beam L.P.	D-5
Marker & Reflector, Right Side — Front	A-2
Marker & Reflector, Left Side — Front	E-2
Marker & Reflector, Right Side — Rear	B-10
Marker & Reflector, Left Side — Rear	E-10
Module Assembly Ignition, 8-Cylinder	B-3
Module Assembly Ignition, 6-Cylinder	D-3

NOMENCLATURE	LOCATION
Neutral Safety Switch	D-9
Oil Lamp Gauge	B-6
Oil Pressure Sender, 8-Cylinder	B-3
Oil Pressure Sender, 6-Cylinder	D-3
Panel Lamp	B-6
Park & Signal Lamp, Right Side	A-1
Park & Signal Lamp, Left Side	D-1
Parking Brake	C-6
Four Wheel Drive Indicator	C-9, D-9
Resistor, Heater Blower Motor	B-5
Splice A	A-2
Splice B	B-2
Splice C	C-2
Splice D	E-2
Splice E	E-2
Splice F	E-2
Splice G	A-3
Splice H	A-3
Splice I	A-3
Splice J	B-3
Splice K	C-3
Splice L	C-3
Splice M	D-4
Splice N	B-5
Splice O	B-5
Splice P	C-5
Splice Q	B-6
Splice R	B-6
Splice S	C-6
Splice T	C-6
Splice U	C-6
Splice V	C-6
Splice W	C-6
Splice X	D-7
Splice Y	E-8
Starting Motor, 8-Cylinder	A-3
Starting Motor, 6-Cylinder	C-4
Starter Solenoid, 8-Cylinder	A-3
Starter Solenoid, 6-Cylinder	C-3
Stop Lamp Switch	D-5
Tail & Stop Lamp, Right Side	C-11
Tail & Stop Lamp, Left Side	D-11
Temperature Gauge	B-7
Temperature Sender, 8-Cylinder	A-4
Temperature Sender, 6-Cylinder	C-4
Turn Signal Switch	D-6
Voltmeter Gauge	B-7
Windshield Wiper & Washer Lamp	D-7
Windshield Wiper Motor	C-9
Windshield Wiper & Washer Switch	D-7

Wiring Diagram Cherokee – Wagoneer – Truck Models

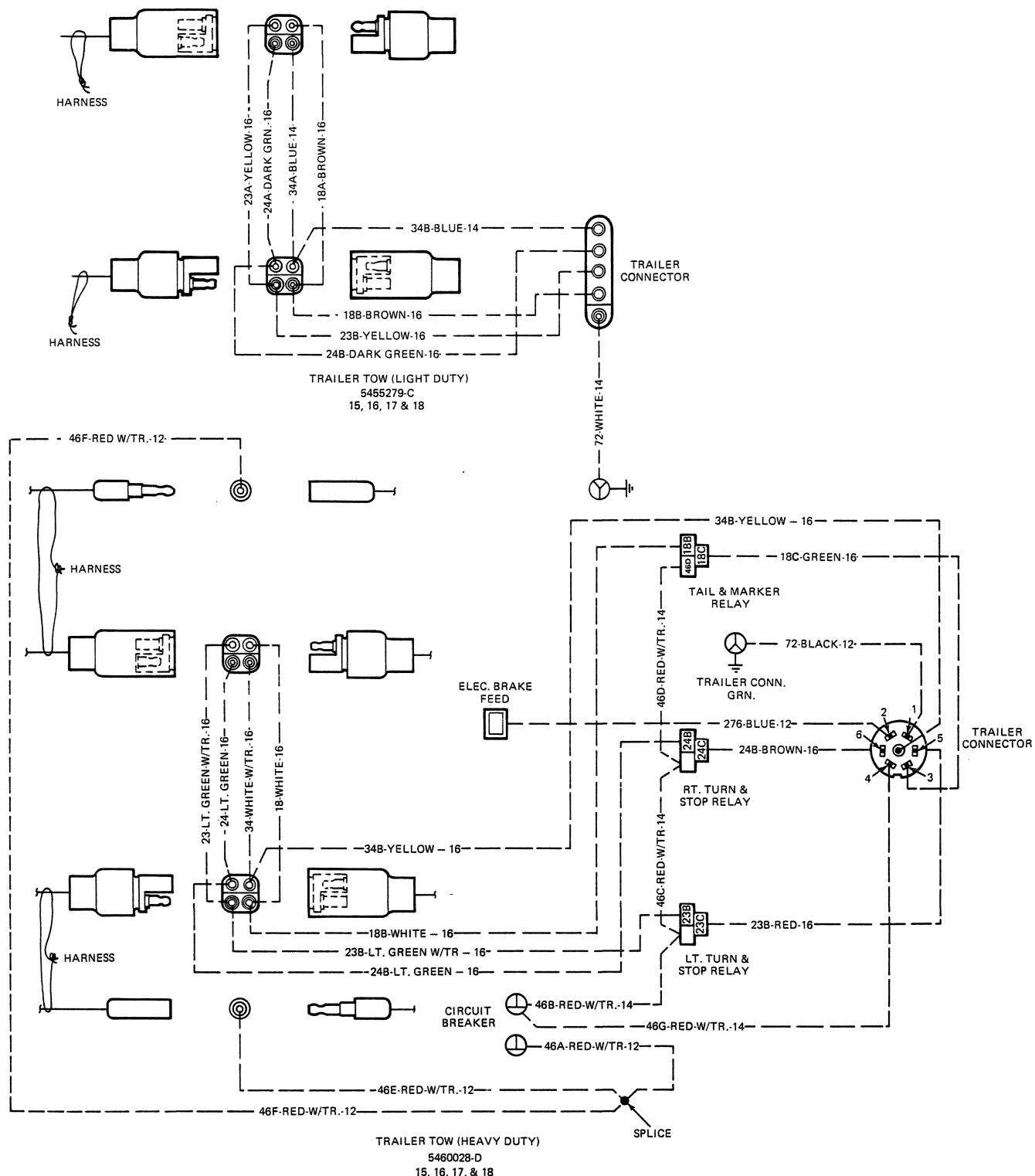

LEGEND:
 1. WIRE CALLOUT CIRCUIT COLOR GAUGE
 46A RED 12

2. CIRCUIT SYM ——— STANDARD CIRCUITS
 - - - - - OPTIONAL EQUIP. CIRCUITS

SYM	STUD	SYM	STUD
⊕ #2	⊕ 1/4	⊗ #8	⊕ 7/16
⊖ #4	⊕ 5/16	⊕ #10	⊗ 1/2
⊗ #6	⊖ 3/8	⊖ #12	⊗ 5/8

Trailer Towing Package

Component Grid Locator
Cherokee - Wagoneer - Truck

A

B

C

D

E

NOMENCLATURE	LOCATION
Air Conditioner Compressor, 6-Cylinder	D-4
Air Conditioner Compressor, 8-Cylinder	C-3
Alternator, 6-Cylinder	C-1
Alternator, 8-Cylinder	B-2
Ash Tray Lamp Feed	C-6
Back-up Lamp, Left Side	D-11, E-11
Back-up Lamp, Right Side	A-11, B-11
Battery, 6-Cylinder	B-3
Battery, 8-Cylinder	A-4
Body Ground, 6-Cylinder	B-3
Body Ground, 8-Cylinder	A-4
Brake Warning	E-8
Capacitor Jumper, 6-Cylinder	B-2
Capacitor Jumper, 8-Cylinder	A-2
Cargo Lamp	B-9
Cargo Lamp Switch	C-9
Chassis Ground, 6-Cylinder	B-3
Chassis Ground, 8-Cylinder	A-4
Cigar Lighter	B-6
Cluster Connection	B-6
Coil, 6-Cylinder	B-2
Coil, 8-Cylinder	B-2
Courtesy Lamp	B-8, D-9
Defogger	D-14
Dimmer Switch	D-6
Distributor, 6-Cylinder	D-2
Distributor, 8-Cylinder	C-2
Dome Lamp	D-8
Dome LP	C-12
Door Switch	B-10, D-10
Electric Choke, 6-Cylinder	C-3
Electric Choke, 8-Cylinder	C-2
Frame Harness	E-4
Fuel Sender	E-9
Glove Box Lamp Feed	A-8
Glove Box Light	B-13
Headlamp, Left Side	D-1
Headlamp, Right Side	B-1
Heater Blower Motor, 8-Cylinder	D-3
Heater Control Switch	C-8
Heater Ground	C-8
Heater Lamps	C-6
Horn Relay	D-6
Horns	E-3
Ignition Switch, Left Side	B-6
Ignition Switch, Right Side	A-6
Light Switch	D-7
License Lamp	C-10
License Lamp	C-11
License Lamp	D-14
Marker & Reflector	B-10
Marker & Reflector	D-11
Marker & Reflector	D-10
Marker & Reflector Lamp, Left Side	E-2
Marker & Reflector Lamp, Right Side	A-2
Module Assembly Ignition, 6-Cylinder	D-1

NOMENCLATURE	LOCATION
Module Assembly Ignition, 8-Cylinder	C-2
Oil Pressure, 6-Cylinder	D-3
Oil Pressure, 8-Cylinder	C-4
Park & Signal Lamp, Left Side	D-1
Park & Signal Lamp, Right Side	B-1
Parking Brake Warning Switch	C-6
Relay	B-12
Seat Belt Buzzer	D-7
Seat Belt Lamp	E-7
Seat Belt Timer	D-7
Splice A	B-2
Splice B	B-2
Splice C	B-1
Splice D	C-1
Splice E	D-2
Splice F	E-2
Splice G, 8-Cylinder	B-3
Splice H, 8-Cylinder	C-3
Splice I, 8-Cylinder	B-3
Splice J	A-5
Splice K	B-5
Splice L	C-5
Splice M	B-5
Splice N	B-5
Splice O	B-6
Splice P	C-6
Splice Q	B-6
Splice R	C-7
Splice S	D-7
Splice T	C-9
Splice U	C-13
Splice V, 6-Cylinder	C-2
Splice W, 6-Cylinder	C-3
Splice X, 6-Cylinder	C-3
Splice Y, 6-Cylinder	D-4
Splice Z, 8-Cylinder	C-3
Starter Solenoid, 6-Cylinder	C-2
Starting Motor, 6-Cylinder	C-3
Starting Motor, 8-Cylinder	B-3
Stop Light Switch	A-7
Stop Light Switch & Cruise Control	B-12
Tai & Stop Lamp	B-10
Tail & Stop Lamp	C-10
Tailgate Switch	D-7
Tail, Stop & Back-up Lamp	B-11
Tail, Stop & Back-up Lamp	D-11
Tail, Stop & Marker Lamp	A-11
Tail, Stop & Marker Lamp	E-11
Temperature Sender, 6-Cylinder	D-3
Temperature Sender, 8-Cylinder	C-4
Timer Switch	C-14
Turn Signal Switch	A-6
Washer Bottle	D-3
Windshield Wiper Motor, 6-Cylinder	E-3
Windshield Wiper Motor, 8-Cylinder	D-3
Windshield Wiper Switch	D-6

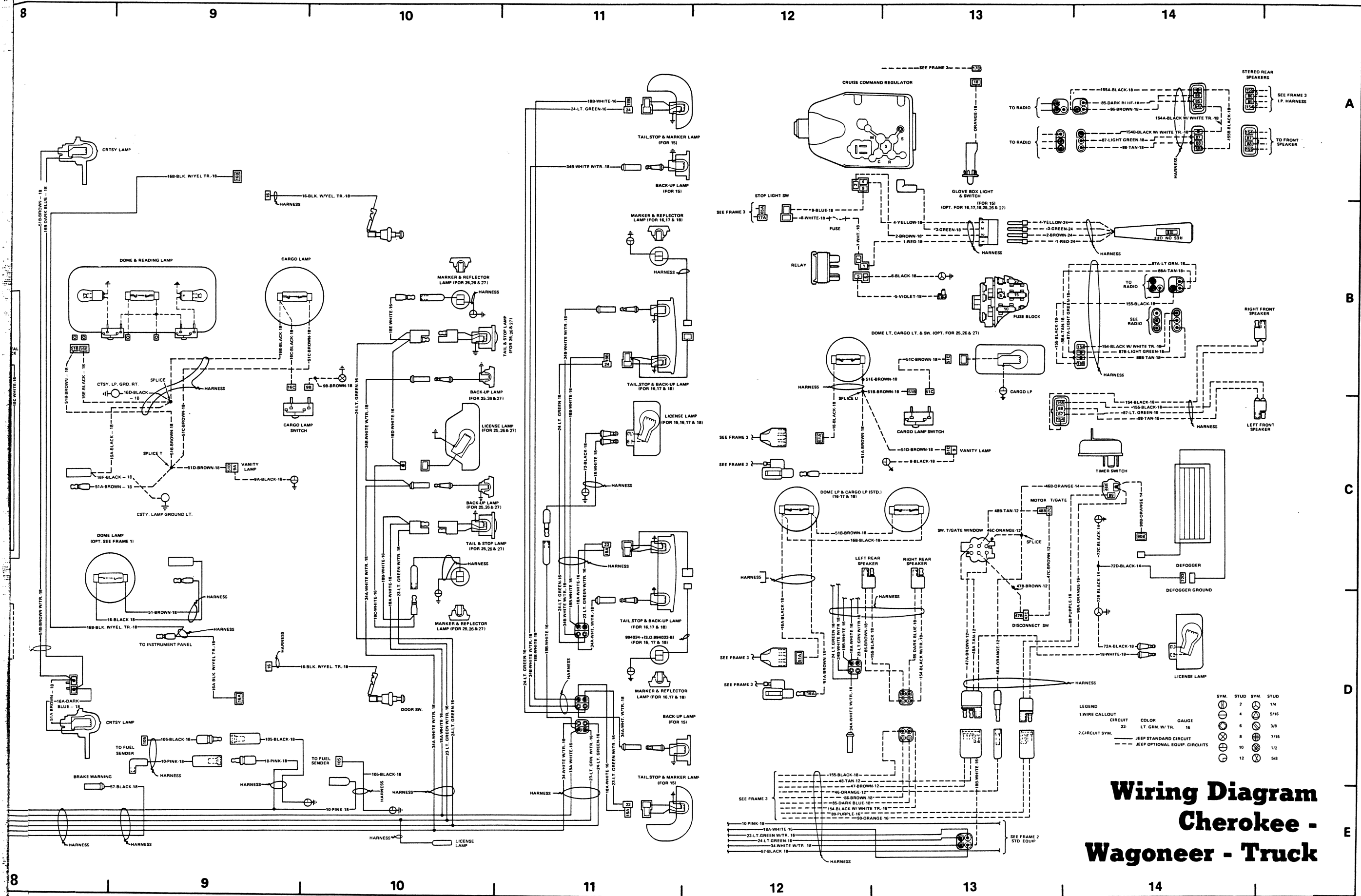

LEGEND

1. WIRE CALLOUT
23 LT. GRN. W/ TR. 16

2. CIRCUIT SYM.
— JEEP STANDARD CIRCUIT
--- JEEP OPTIONAL EQUIP. CIRCUITS

SYM.	STUD	SYM.	STUD
⊕	2	⊖	1/4
⊙	4	⊗	5/16
⊘	6	⊗	3/8
⊙	8	⊗	7/16
⊘	10	⊗	1/2
⊙	12	⊗	5/8

Wiring Diagram Cherokee - Wagoneer - Truck

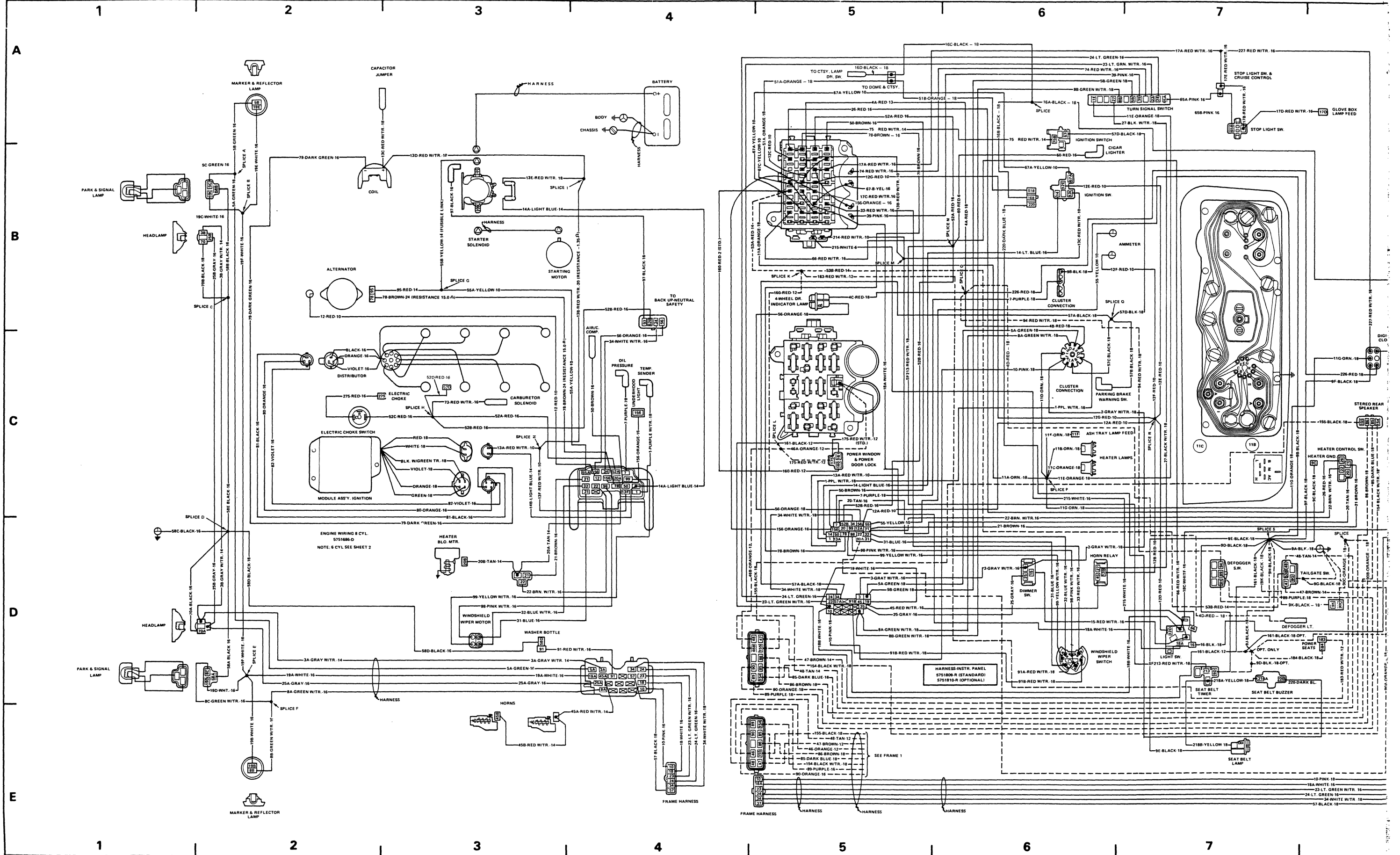

Accessory Diagrams
CJ - Cherokee - Wagoneer - Truck Models

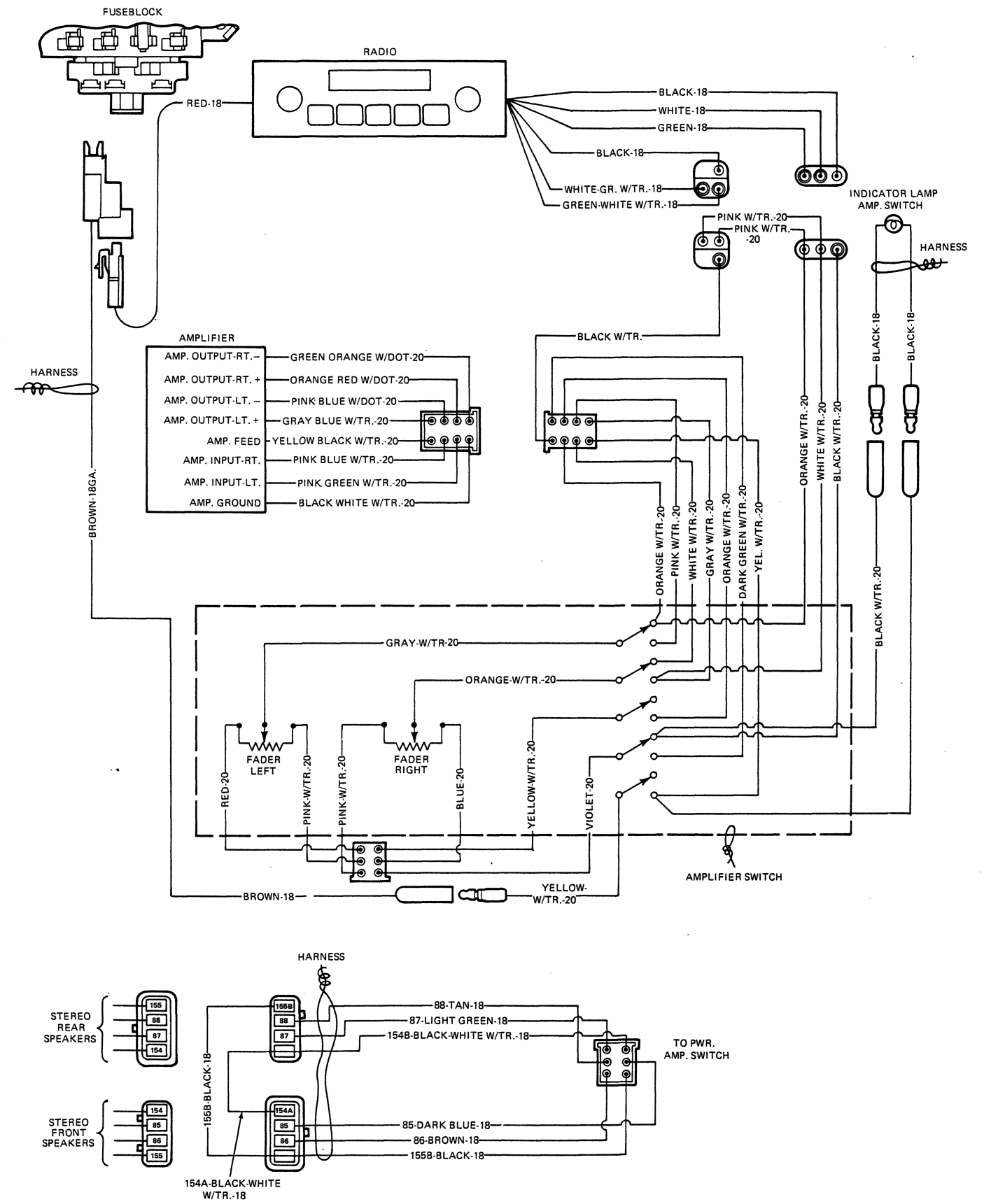

RADIO
POWER AMP.

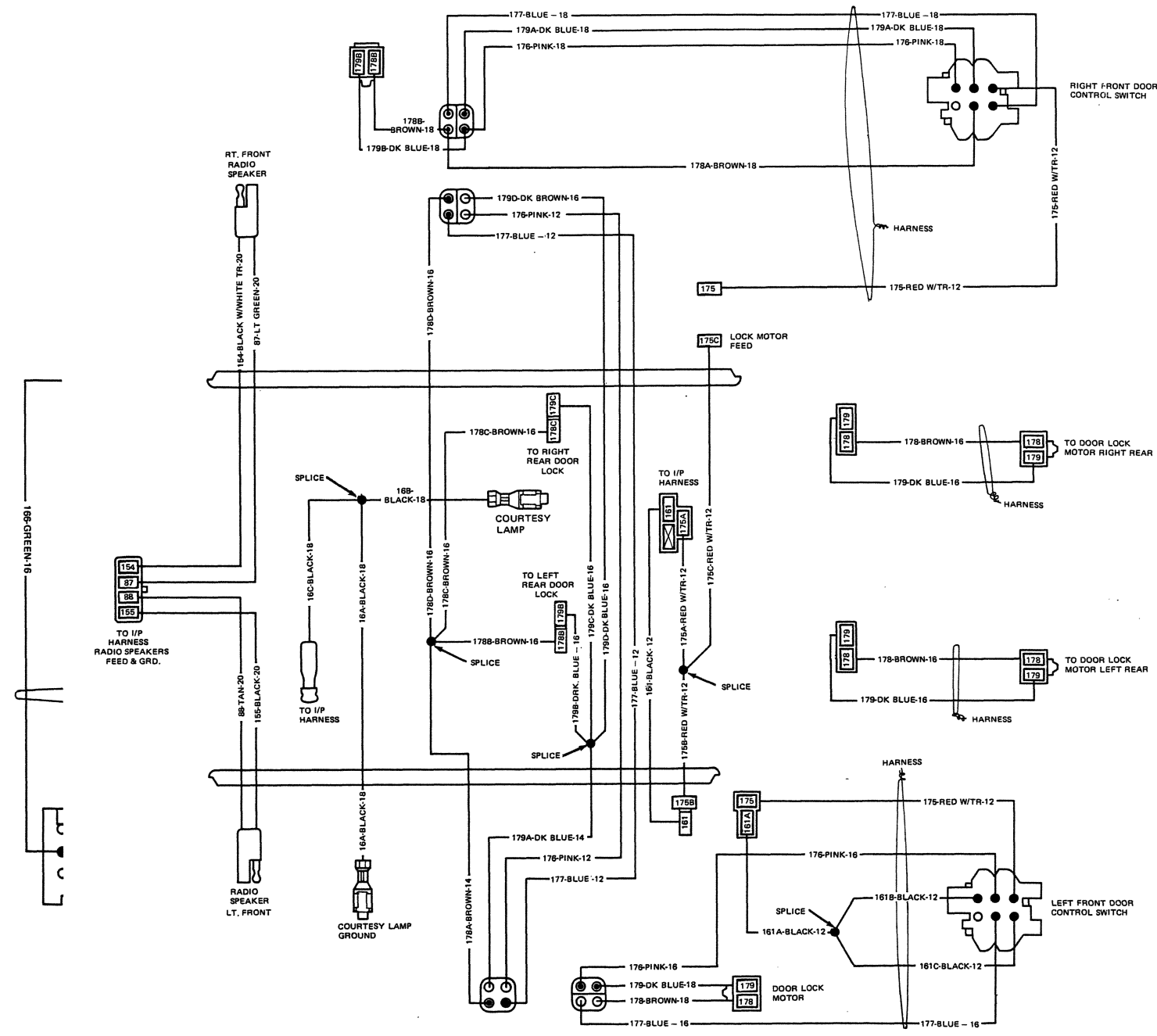

POWER DOOR LOCK DIAGRAM

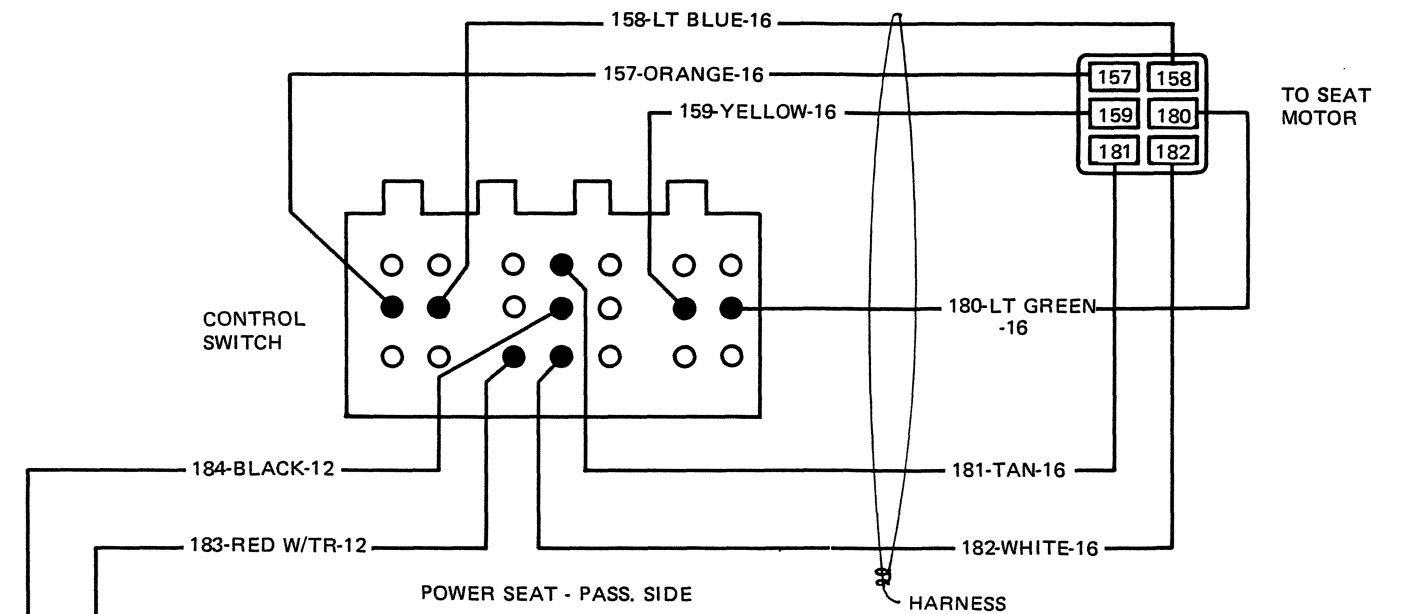

POWER SEAT - PASS. SIDE

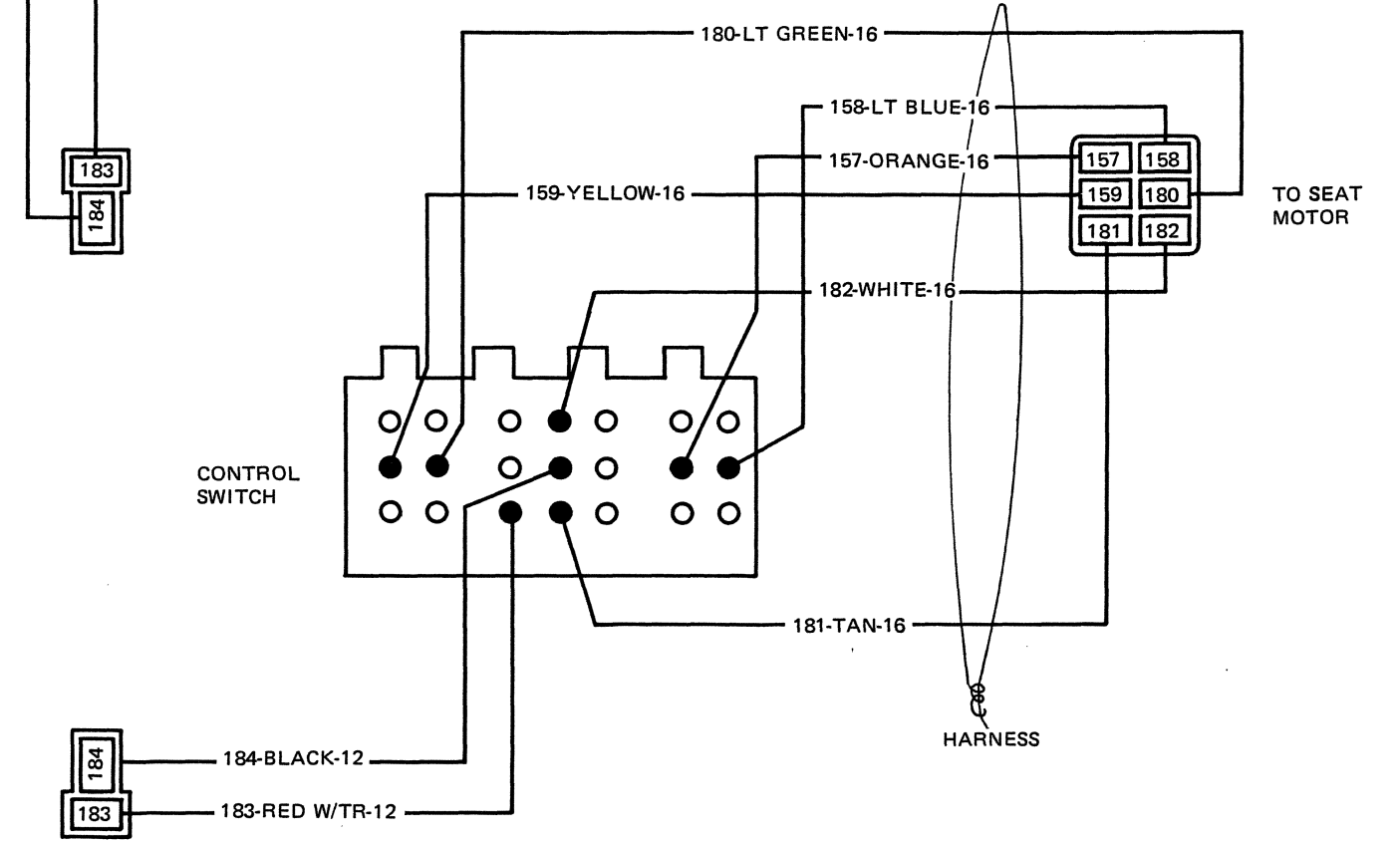

POWER SEAT - DRIVERS SIDE

POWER SEAT DIAGRAM

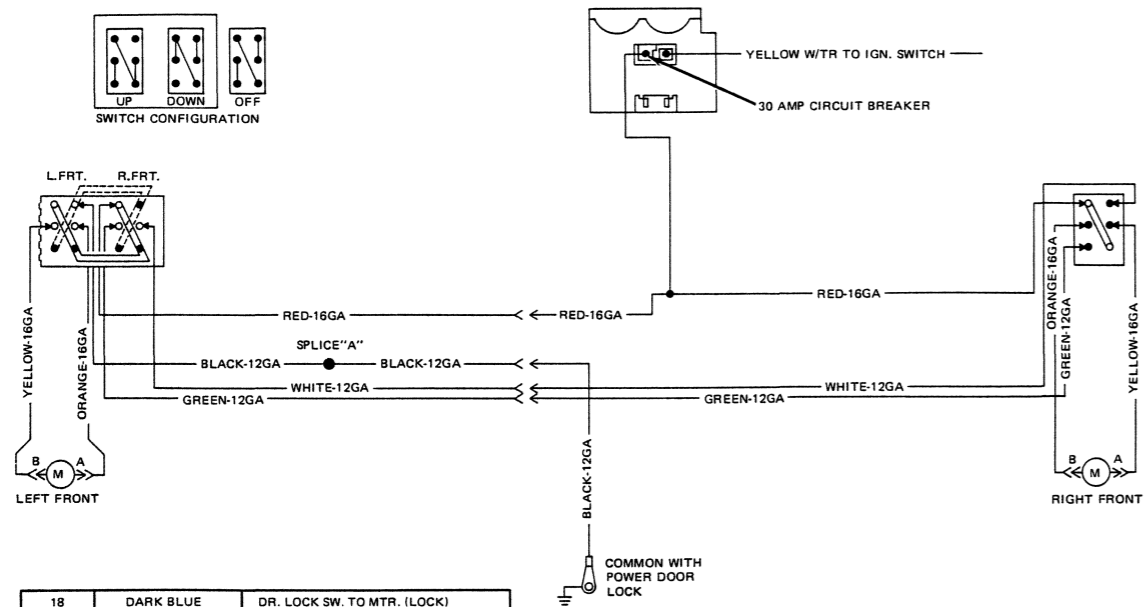

18	DARK BLUE	DR. LOCK SW. TO MTR. (LOCK)
18	BROWN	DR. LOCK SW. TO MTR. (UNLOCK)
16	BLUE	DR. LK. LT. SW. TO RT. SW. UNLOCK
16	PINK	DR. LK. LT. SW. TORT. SW. LOCK
12	RED TR.	POWER DOOR LOCK-FEED
12	BLACK	POWER LOCKS - GRD.
12	BLACK	POWER LOCKS - GRD.
12	BLACK	POWER LOCKS - GRD.
GA.	COLOR - MAT'L	CIRCUIT DESCRIPTION

Jeep Power Windows 2 Door

90971B

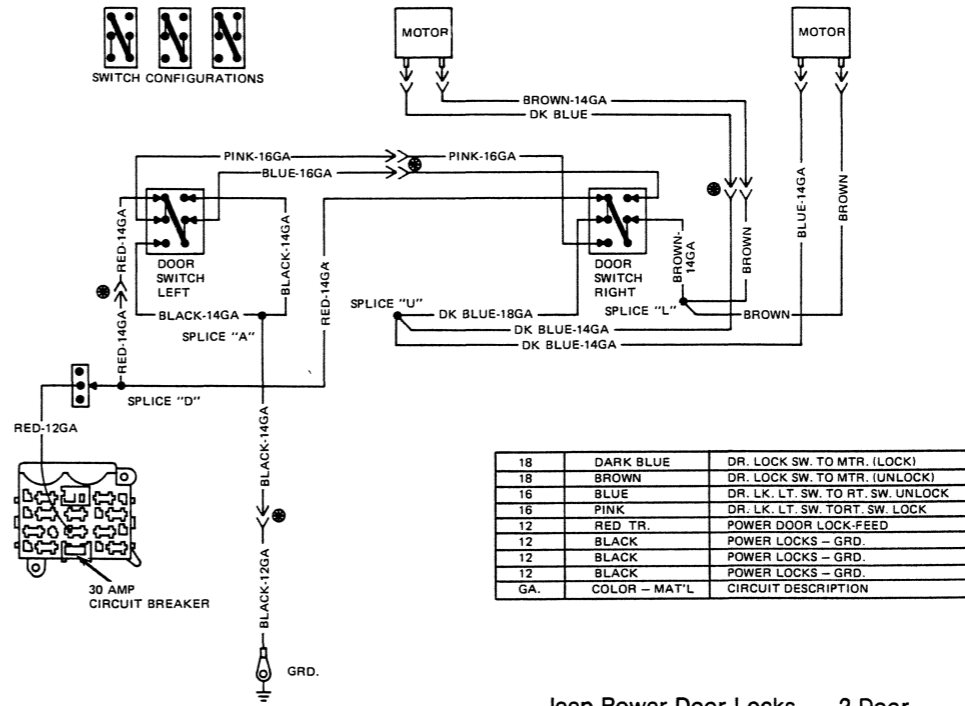

18	DARK BLUE	DR. LOCK SW. TO MTR. (LOCK)
18	BROWN	DR. LOCK SW. TO MTR. (UNLOCK)
16	BLUE	DR. LK. LT. SW. TO RT. SW. UNLOCK
16	PINK	DR. LK. LT. SW. TORT. SW. LOCK
12	RED TR.	POWER DOOR LOCK-FEED
12	BLACK	POWER LOCKS - GRD.
12	BLACK	POWER LOCKS - GRD.
12	BLACK	POWER LOCKS - GRD.
GA.	COLOR - MAT'L	CIRCUIT DESCRIPTION

Jeep Power Door Locks 2 Door

90970C

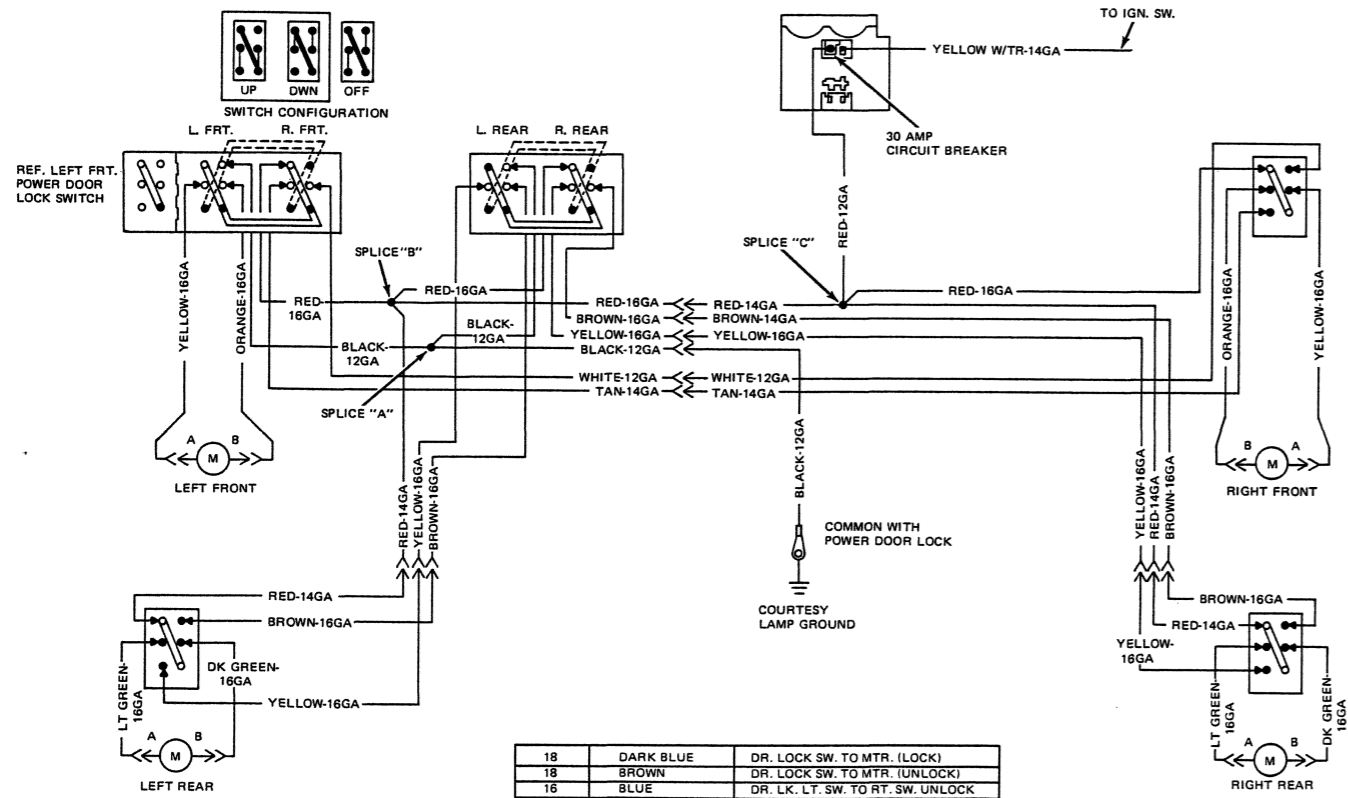

18	DARK BLUE	DR. LOCK SW. TO MTR. (LOCK)
18	BROWN	DR. LOCK SW. TO MTR. (UNLOCK)
16	BLUE	DR. LK. LT. SW. TO RT. SW. UNLOCK
16	PINK	DR. LK. LT. SW. TORT. SW. LOCK
12	RED TR.	POWER DOOR LOCK-FEED
12	BLACK	POWER LOCKS - GRD.
12	BLACK	POWER LOCKS - GRD.
12	BLACK	POWER LOCKS - GRD.
GA.	COLOR - MAT'L	CIRCUIT DESCRIPTION

Jeep Power Windows 4 Door

90971A

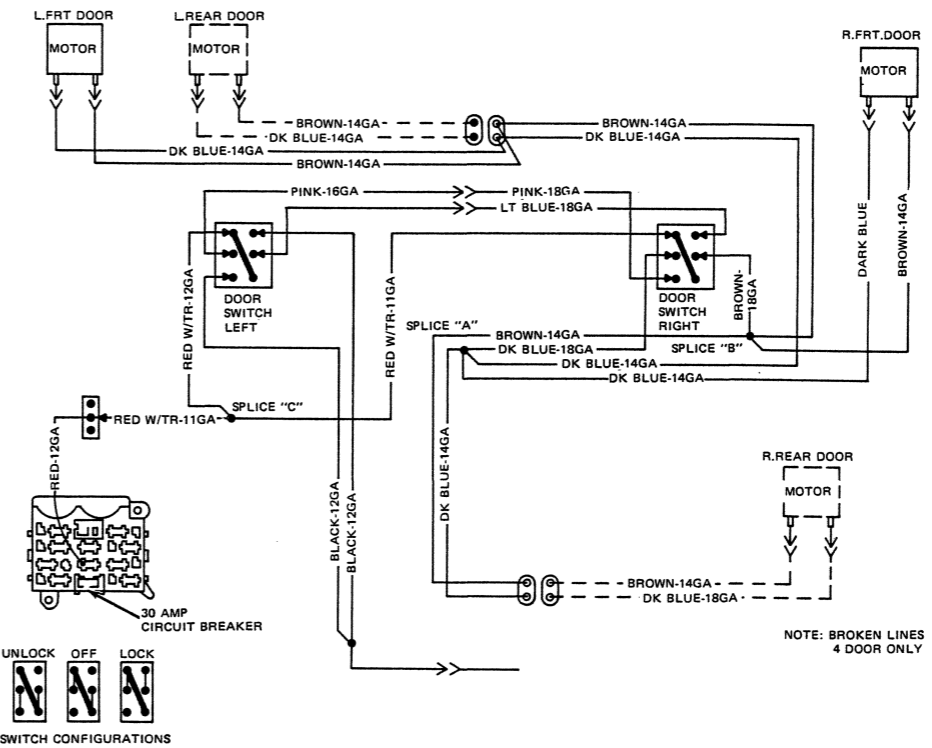

18	DARK BLUE	DR. LOCK SW. TO MTR. (LOCK)
18	BROWN	DR. LOCK SW. TO MTR. (UNLOCK)
16	BLUE	DR. LK. LT. SW. TO RT. SW. UNLOCK
16	PINK	DR. LK. LT. SW. TORT. SW. LOCK
12	RED TR.	POWER DOOR LOCK-FEED
12	BLACK	POWER LOCKS - GRD.
12	BLACK	POWER LOCKS - GRD.
12	BLACK	POWER LOCKS - GRD.
GA.	COLOR - MAT'L	CIRCUIT DESCRIPTION

Jeep Power Door Locks 4 Door

90970B

Jeep Power Windows And Power Door Locks

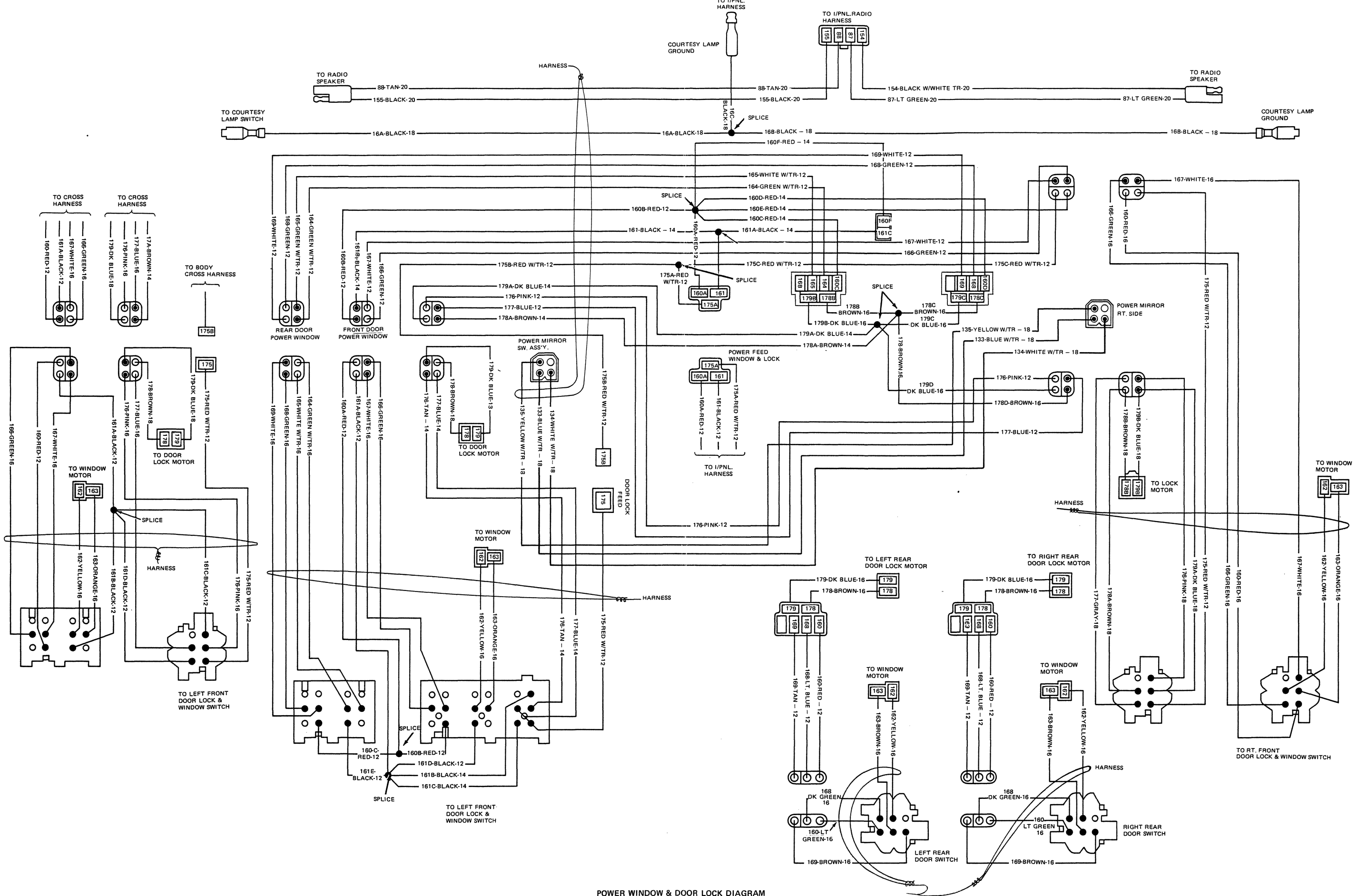

POWER WINDOW & DOOR LOCK DIAGRAM