

WINDSHIELD - REAR WINDOW

3N

SECTION INDEX

| | | | |
|-------------|------|------------|------|
| | Page | | Page |
| Rear Window | 3N-6 | Windshield | 3N-1 |

WINDSHIELD

| | | | |
|--|------|--------------------------|------|
| | Page | | Page |
| Cherokee-Wagoneer-Truck Windshield Glass | 3N-2 | Rear View Mirror Bracket | 3N-5 |
| CJ Folding Windshield | 3N-1 | Tools | 3N-7 |
| CJ Windshield Glass | 3N-2 | Specifications | 3N-6 |
| General | 3N-1 | | |

GENERAL

The windshields on all models consist of two sheets of plate glass laminated together to form a one-piece safety glass.

All CJ windshields are retained in their openings by rubber weatherstrips (channels).

Cherokee-Wagoneer-Truck model windshields are bonded to the rubber weatherstrip and the rubber weatherstrip is bonded to the body opening to improve glass retention and sealing.

The safety type glass is designed with adequate clearance to prevent stress and strains. When replacing cracked glass resulting from causes other than a direct blow or a known instance of temporary misalignment, it is very important that the cause of the breakage be determined and the condition corrected.

The inside rear view mirror bracket for all models is bonded directly to the windshield glass with a polyvinyl-butyl compound through a heat-induction process.

Service replacement windshield glass may have the rear view mirror bracket bonded to the windshield glass. In this case, the mirror is simply transferred from the damaged windshield to the bracket on the replacement windshield.

If the replacement windshield does not have a bonded mirror bracket or if the bonded bracket has been lost, a service kit is available for bracket installation. The kit is available from your local parts distribution center and consists of a replacement bracket and a firm-setting, two-component adhesive. Installation instructions are included in the kit, and also in this section.

NOTE: Do not attempt to remount the original bracket. Use a new bracket kit.

CJ FOLDING WINDSHIELD

The windshield and frame assembly may be lowered to the hood by removing the knobs at each side of the windshield. When in the lowered position, always secure the windshield by passing the strap at the top of the windshield through the footman loop on the hood and drawing the strap up firmly.

Removal

- (1) Remove necessary top components from windshield frame.
- (2) Disconnect wiper motor wiring harness from switch.
- (3) Remove windshield hinge-to-frame attaching screws using Torx Bit Tool J-25359-C.
- (4) Remove windshield holddown knobs and remove windshield frame.

Installation

- (1) Position windshield frame on vehicle and install windshield hinge-to-frame attaching screws using Torx Bit Tool J-25359-C.
- (2) Install windshield holddown knobs.
- (3) Connect wiper motor wiring harness to switch.
- (4) Install necessary top components to windshield frame.

CJ WINDSHIELD GLASS**Removal**

- (1) Cover adjoining painted surfaces to protect finish.
- (2) Remove windshield wiper arms using wide blade screwdriver.
- (3) Remove inside rear view mirror from bracket.
- (4) Remove sun visors and defroster ducts.
- (5) Starting at top of windshield frame, pull glass weatherstrip away from flange while gently pushing out on glass.
- (6) Work entire weatherstrip from pinch weld flange and remove glass.

Installation

- (1) Using 3M Auto Bedding and Glazing Compound or equivalent, apply a 1/16-inch bead of sealer completely around weatherstrip in flange cavity.
- (2) Install weatherstrip on glass. Split in weatherstrip should be centered on bottom edge of glass.
- (3) Beginning at bottom of glass, work weatherstrip over flange using fiber or wooden wand.
- (4) Apply 3M Windshield Sealer or equivalent, between weatherstrip and outside of glass around entire perimeter.
- (5) Clean off excess sealer.
- (6) Install inside rear view mirror on bracket.
- (7) Install defroster ducts and sun visors.
- (8) Install windshield wiper arms.
- (9) Test windshield installation for water leaks.

CHEROKEE-WAGONEER-TRUCK WINDSHIELD GLASS

A self-curing urethane adhesive is used to bond the windshield glass to the rubber weatherstrip and the rubber weatherstrip to the body opening. This material provides the strength necessary to meet the FMVSS regulation covering windshield retention.

NOTE: *FMVSS regulations require compliance to the standards throughout the life of the vehicle. Therefore, all windshields must be replaced with Windshield Glass Installation Kit (Urethane), Part Number 8128954, or equivalent, to assure compliance.*

Tools and Materials

The following tools and materials are necessary for a windshield replacement:

- (1) Windshield glass installation kit consisting of the following components:
 - (a) Instruction sheets
 - (b) One six-ounce cartridge of urethane adhesive
 - (c) One pointed dispensing nozzle

- (d) Five daubers for applying glass and rubber cleaners and primers
 - (e) Glass blackout primer
 - (f) Rubber primer
 - (g) Paint finish primer
 - (h) Glass cleaner
 - (i) Rubber cleaner
- (2) One six-ounce, hand-operated Adhesive Gun J-24811, or equivalent.
- (3) Electric Hot Knife J-24709-01, or equivalent.
- (4) Razor-blade type knife.
- (5) Masking tape.
- (6) Isopropyl alcohol (rubbing alcohol).
- (7) Clean wiping rags or paper towels.
- (8) Methyl-ethyl-ketone (MEK) or toluene.
- (9) Grow Chemical Solvent GS-35, or equivalent.

NOTE: *Methyl-ethyl-ketone (MEK), toluol (toluene), and Grow Chemical Solvent GS-35 are usually available from chemical houses listed under SOLVENTS in the Yellow Pages of the telephone directory. If not available locally in small quantities, these solvents may be obtained from mail order chemical houses such as E. H. Sargent & Co. and Fisher Scientific, which have sales-service centers throughout the country. This is neither a complete list, nor a recommendation for the exclusive use of the chemical houses listed.*

Water Leaks

Water leaks around windshields installed with urethane adhesive can be corrected without removing the windshield glass.

NOTE: *If the windshield is structurally sound in the body opening, without large breaks in the bond, water leaks may be corrected by using a liquid butyl sealer such as 3M Windo-Weld Resealant or equivalent. When the windshield is not structurally sound in the body opening, the following procedure will apply and will require one Windshield Glass Installation Kit.*

- (1) Remove windshield reveal moulding, if equipped.
- (2) Water test around the entire sealing area of windshield.

(a) Always begin water spray at lowest point and allow sufficient saturation before moving water spray upward.

(b) To best simulate normal conditions that cause water leaks, i.e., rain or washing, water test with a spray pattern rather than a heavy, solid stream of water which can create misleading symptoms.

NOTE: *If leak is between windshield glass and rubber weatherstrip, or between rubber weatherstrip and body, carefully push outward on glass in area of leak to determine extent of leak. This operation should be performed while water is being applied to leak area. Mark extent of leak area.*

(3) From outside body, clean dirt or foreign material from leak area with water; then completely dry area with compressed air.

(4) If leak is between glass and rubber weatherstrip, proceed as follows:

(a) Clean glass area to be resealed with windshield cleaner included in windshield installation kit.

(b) Using dauber, apply glass blackout primer to edge of glass, in leak area.

(c) Using a clean dauber, apply rubber primer to rubber weatherstrip, in leak area.

(d) Apply urethane adhesive, using pointed nozzle supplied with kit, in leak area.

(5) If leak is between rubber weatherstrip and body, proceed as follows:

(a) Using dauber as supplied in windshield installation kit, apply rubber primer to rubber weatherstrip, in leak area.

(b) Using clean dauber, apply paint finish primer, in leak area.

(c) Apply urethane adhesive in leak area using pointed nozzle supplied with kit.

(6) Water test windshield immediately using cold water spray. Allow water to spill over edge of glass and rubber weatherstrip. Do not direct hard stream of water on fresh urethane adhesive.

(7) Install all previously removed parts.

Removal

(1) Cover adjoining painted surfaces to protect finish.

(2) Remove windshield wiper arms using wide blade screwdriver.

(3) On vehicles with stainless steel mouldings, perform the following steps.

(a) Remove moulding screws on top and bottom of side mouldings.

(b) Remove top corner moulding by lifting bottom and pulling outboard.

(c) Tip side mouldings toward center of vehicle and lift off.

(d) Remove top moulding.

(4) Slide center moulding clip to left or right and remove bottom mouldings. This will expose the locking type weatherstrip.

(5) Use wedge-shaped fiber or hardwood stick or wand as shown in figure 3N-1 to unlock weatherstrip as shown in figure 3N-2.

(6) Unlock rubber weatherstrip starting at bottom with fiber stick or wand as shown in figure 3N-3.

(7) Remove inside rear view mirror from bracket.

(8) Use razor-blade knife to cut rubber weatherstrip, in locking lip groove, between glass and body flange.

(9) Remove windshield glass from body opening.

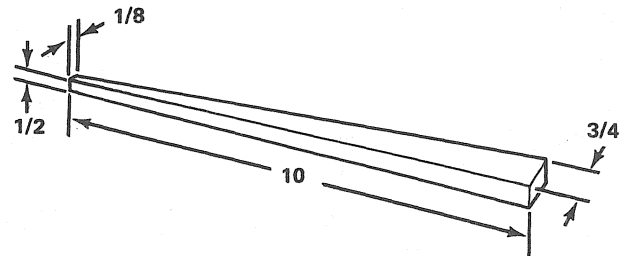

J42670

Fig. 3N-1 Wooden Wand Dimensions (Inches)

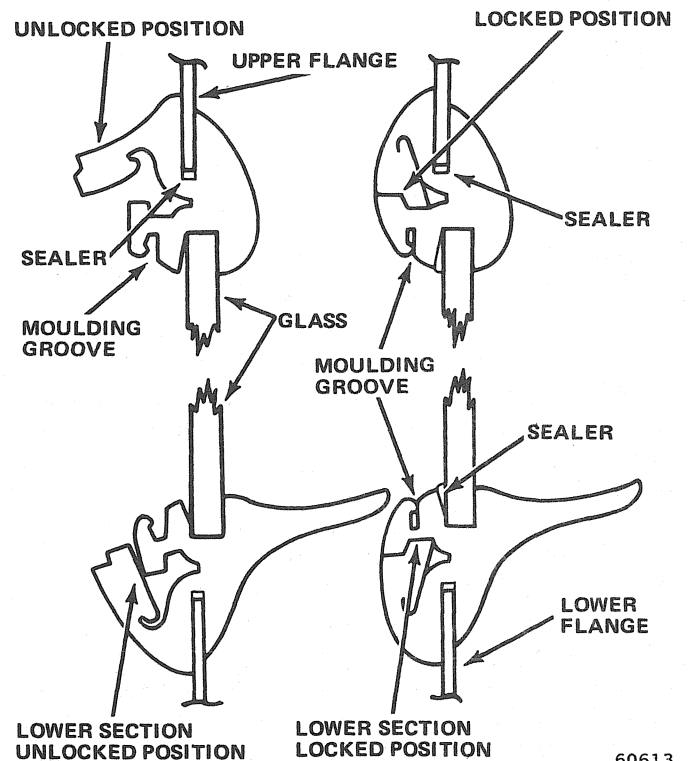

60613

Fig. 3N-2 Windshield Weatherstrip Cross Section—Moulding Removed

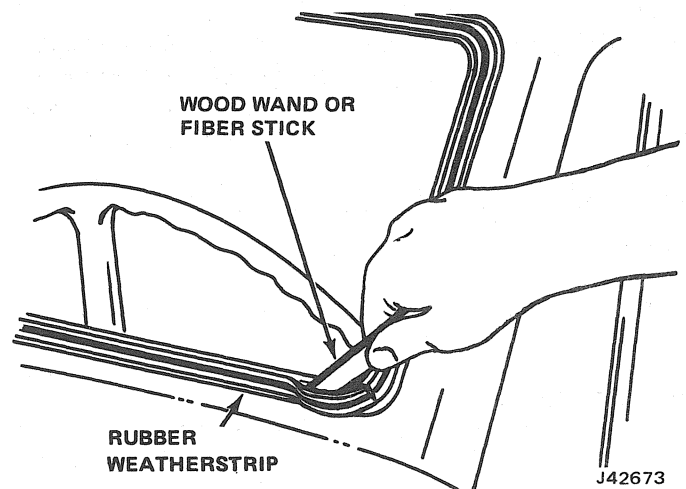

J42673

Fig. 3N-3 Unlocking Rubber Weatherstrip

(10) Remove rubber weatherstrip from body opening flange.

NOTE: *Inspect for uneven surfaces or irregularities in the windshield opening flange that could cause stress damage to the windshield glass.*

(11) Remove silicone sealer from weatherstrip and vinyl roof, if equipped.

(12) Remove old urethane adhesive from body opening flange using razor-blade type knife or Electric Hot Knife J-24709-01 equipped with the Plow-Type Blade J-24851.

NOTE: *Do not damage the painted surface of the body during above procedure.*

Installation

NOTE: *Windshield installation should be accomplished in relatively warm surroundings so that the windshield rubber weatherstrip remains pliable making installation easier and reducing the possibility of breaking the windshield glass.*

When a replacement windshield glass is installed, a replacement mirror bracket must be installed if the replacement windshield glass is not equipped with one. Follow the detailed procedure in this Chapter or with the mirror bracket kit supplied as a service part.

(1) Apply one-inch wide masking tape to outside of glass 1/2-inch inboard from edge of glass; apply tape to top, sides and bottom as shown in figure 3N-4.

(2) Using dauber supplied in kit, wipe surface of glass to which glass blackout primer will be applied (between masking tape and including edge of glass).

(3) Using clean dauber, apply 1/2-inch band of glass blackout primer around entire outside of glass and outer edge. Allow primer to dry for 10 minutes.

CAUTION: *Use care not to spill or drip glass blackout primer on painted or trimmed surfaces. Wipe spills immediately as primer will etch trim or painted surfaces.*

(4) Obtain replacement rubber weatherstrip. Using clean dauber, wipe glass cavity and body flange cavity clean.

(5) Using another dauber, apply rubber primer around inside of glass cavity and body flange cavity. Allow primer to dry for 30 minutes.

(6) Using isopropyl alcohol dampened rag, wipe body opening flange clean and allow to dry.

(7) Apply 2-inch wide masking tape on outside of windshield opening at roof, A-pillars and cowl top to prevent damaging body paint.

(8) Using clean dauber or brush, apply paint finish primer to body opening flange as shown in figure 3N-5. Allow primer to dry for 25 minutes.

NOTE: *Do not use glass blackout primer on body opening flange.*

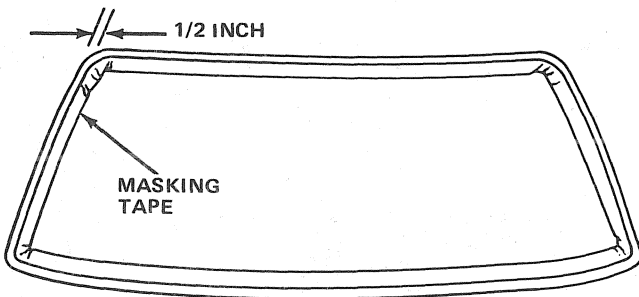

80421

Fig. 3N-4 Installation of Windshield Glass Masking Tape

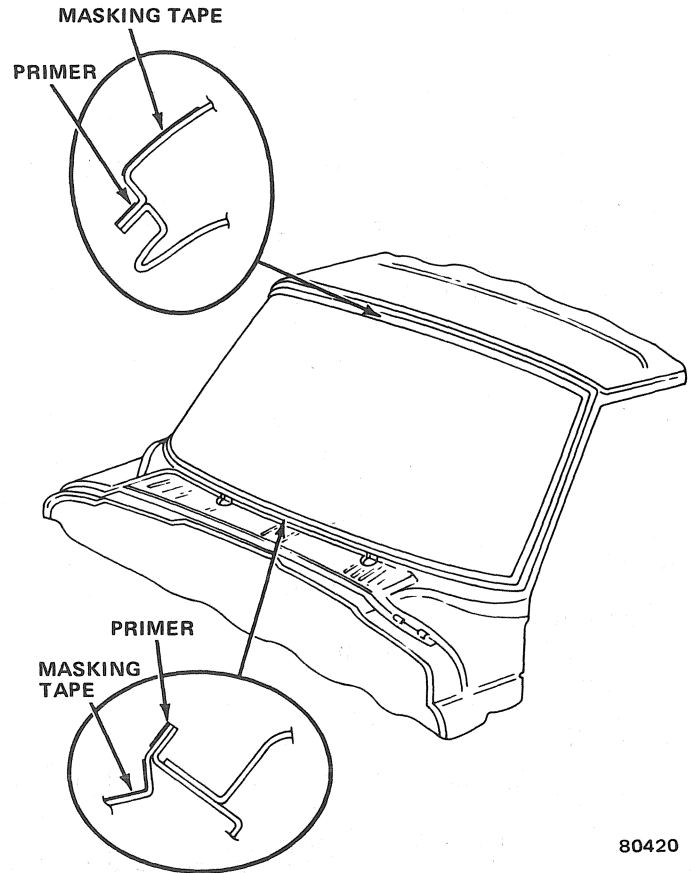

80420

Fig. 3N-5 Installing Body Opening Masking Tape and Primer

(9) Apply smooth, continuous bead of urethane adhesive material inside of rubber weatherstrip body flange cavity. Bead should be 1/8-inch in diameter.

(10) Install rubber weatherstrip on windshield opening flange.

(11) Apply liberal amount of soap and water solution to edge of windshield glass.

(12) Place 1/8-inch diameter cord in bottom glass cavity of rubber weatherstrip.

- (13) Remove masking tape from windshield glass.
- (14) With two men working on outside of vehicle, work windshield into upper glass cavity and into each side.
- (15) Position wooden wand (fig. 3N-1) under bottom of glass and lift windshield up and into lower glass cavity.
- (16) Check for equal side clearances.
- (17) Wipe soap and water solution from windshield glass and rubber weatherstrip.
- (18) Apply smooth, continuous bead of urethane adhesive material around entire outside edge of windshield glass and rubber weatherstrip. Bead should be 1/8-inch in diameter.
- (19) Use wooden wand to lock weatherstrip as shown in locked position (fig. 3N-2).

NOTE: Urethane adhesive material begins to cure after 15-minute exposure to air and moisture.

(20) Remove masking tape from body and apply 3M Super Silicone Sealer, or equivalent, along weatherstrip and vinyl roof, if equipped.

(21) Water test windshield immediately using cold water spray. Do not direct hard stream of water on fresh urethane adhesive material. If leaks are encountered, apply extra urethane adhesive material with pointed nozzle.

(22) Bottom mouldings are installed one at a time. To facilitate installation, place 1/8-inch diameter cord in weatherstrip moulding retaining groove along entire length of weatherstrip, leaving enough cord hanging out at each end to permit good grip on cord.

(23) Working first with either left or right bottom moulding, place moulding in groove.

(24) Starting at outside corner of weatherstrip, pull up on cord while lightly tapping top of moulding with rubber mallet. This will lock moulding in weatherstrip retaining groove. Continue process until moulding is installed in weatherstrip. Repeat process with other bottom moulding, again starting at outside corner.

(25) Install center moulding clip to cover gap between left and right bottom moulding.

(26) The one-piece top moulding is installed in same manner, except that moulding is tapped upward into retaining groove.

(27) Side and upper corner mouldings can then be inserted in retaining groove and secured by installing upper and lower screws.

(28) Clean excess urethane adhesive material from windshield, body and mouldings with cloth dampened with Grow Chemical Solvent GS-35, or equivalent.

- (29) Install side moulding screws.
- (30) Install windshield wiper arms.
- (31) Install inside rear view mirror on bracket.

REAR VIEW MIRROR BRACKET

Installation

- (1) Locating windshield mounted rear view mirror bracket can be accomplished as shown in figures 3N-6 and 3N-7. Use wax pencil on outside of glass to locate mounting bracket.

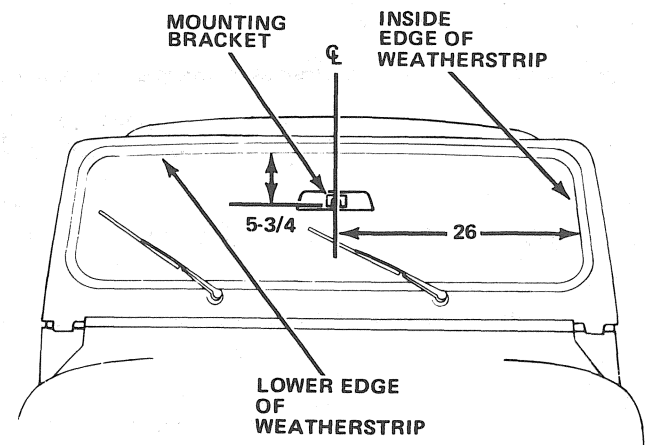

60611

Fig. 3N-6 Windshield Mounted Rear View Mirror Bracket Location (Inches)—CJ Models

- (2) If vinyl pad has remained on windshield glass, apply low heat with an Electric Heat Gun J-25070 until vinyl softens. Then, peel pad from glass using care not to scratch or mar glass surface.

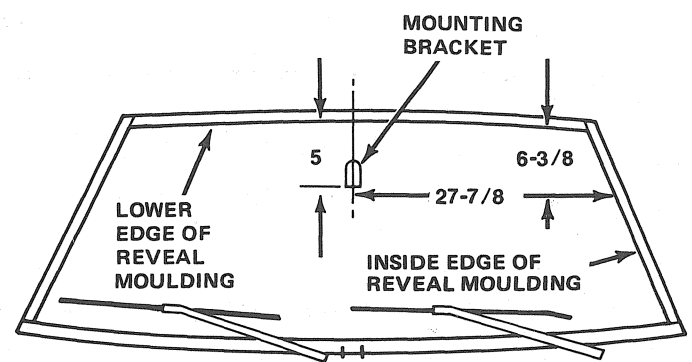

J41066

Fig. 3N-7 Windshield Mounted Rear View Mirror Bracket Location (Inches)—Cherokee-Wagoneer-Truck Models

- (3) Clean bracket mounting area of windshield glass thoroughly. Use mildly abrasive cleaning powder (Ajax, Comet, or equivalent) applied to clean cloth saturated with alcohol.

3N-6 WINDSHIELD—REAR WINDOW

(4) Remove all traces of cleanser by wiping area with paper towel moistened with alcohol.

(5) Scuff bonding surface (the side without the 3/8-inch circular depression) of mirror bracket with clean piece of fine grit sandpaper. Apply alcohol to clean towel and wipe surface clean.

(6) Apply generous amount of accelerator (supplied with kit) to mirror bracket mounting surface. Allow five minutes to dry.

(7) Apply thin film of accelerator to windshield. Allow one minute to dry.

CAUTION: Do not touch surfaces to which accelerator has been applied or an imperfect bond could result.

(8) Apply one drop of adhesive at center of mirror bracket bonding surface. Use bottom of adhesive tube to distribute adhesive evenly over entire surface.

(9) Position bottom straightedge of bracket on horizontal line (fig. 3N-6 and 3N-7). Press bracket to glass and hold firmly for one minute. Be sure bracket is properly located as adhesive sets quickly.

REAR WINDOW

| | Page |
|--|------|
| CJ-7 With Hardtop Enclosure and Cherokee-Wagoneer Models | 3N-6 |
| General | 3N-6 |

| | Page |
|--------------|------|
| Truck Models | 3N-6 |

GENERAL

The rear window is a one-piece, tempered glass. The overall size of the glass varies with the different vehicles.

CJ-7 With Hardtop Enclosure and Cherokee-Wagoneer Models

For service replacement and adjustment of tailgate window glass, refer to Chapter 3H—Liftgates-Tailgates.

Truck Models

For service replacement of solid rear glass, refer to CJ Glass Removal or Installation.

The sliding rear window on J-10 and J-20 cabs which provides cab ventilation and ease of communication between passengers in the truck cab and camper body, is replaced as an assembly.

SPECIFICATIONS

Torque Specifications

Service Set-To Torques should be used when assembling components. Service In-Use Recheck Torques should be used for checking a pre-torqued item.

| | USA (ft -lbs) | | Metric (N·m) | |
|---------------------------------|-----------------------|-----------------------|-----------------------|-----------------------|
| | Service Set-To Torque | In-Use Recheck Torque | Service Set-To Torque | In-Use Recheck Torque |
| Rear View Mirror Setscrew | 15 | 12-20 | 2 | 1-2 |

All Torque values given in inch-pounds and newton-meters with dry fits unless otherwise specified.

70272

Tools

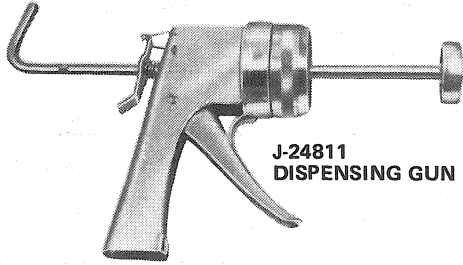

J-24811
DISPENSING GUN

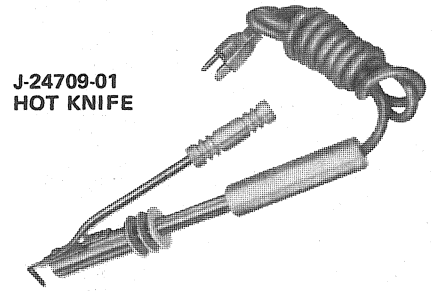

J-24709-01
HOT KNIFE

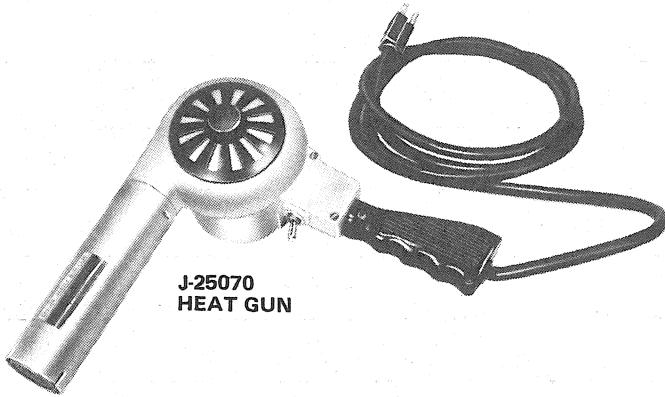

J-25070
HEAT GUN

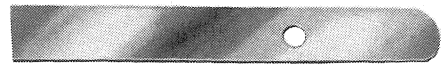

J-24851
PLOW-TYPE
BLADE

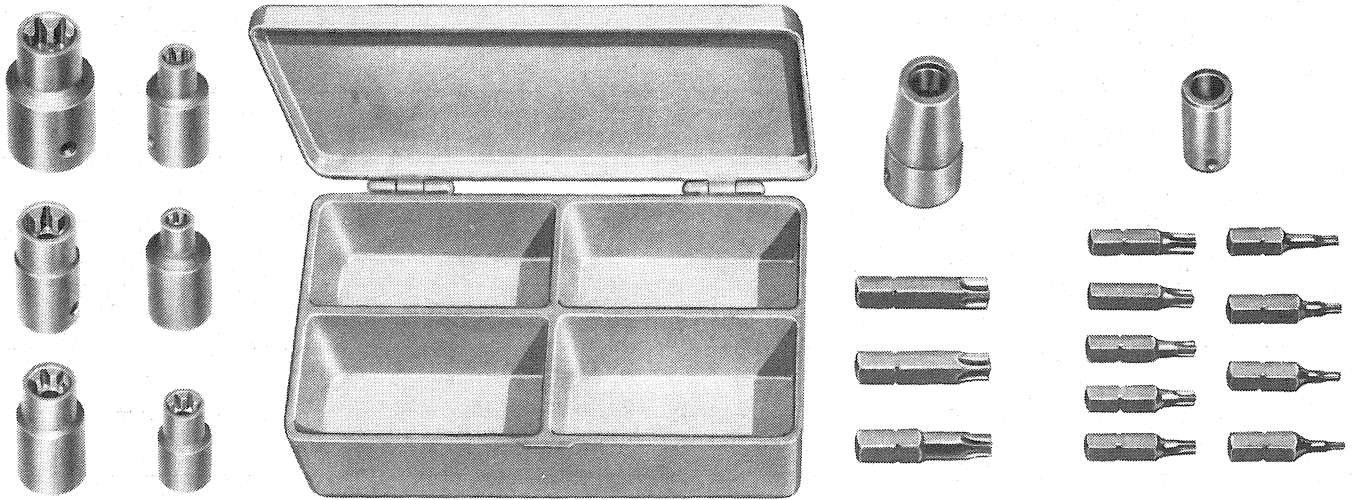

J-25359-C
TORX BIT AND SOCKET SET