

HARDTOP ENCLOSURE- SUN ROOF AND LUGGAGE RACKS

3L

SECTION INDEX

	Page		Page
Hardtop Enclosure	3L-1	Manually Operated Sun Roof	3L-5
Luggage Rack	3L-14	Tools	3L-16
Power Sun Roof—Wagoneer Limited	3L-7		

HARDTOP ENCLOSURE

	Page		Page
General	3L-1	Removal	3L-1
Installation	3L-1	Repair	3L-1

GENERAL

A lightweight, removable hardtop enclosure is available for CJ-7 models. The top is constructed of compression molded fiberglass. The hardtop enclosure and steel liftgate are painted with a special spatter finish.

REMOVAL

- (1) Remove screws attaching hardtop enclosure to windshield frame (fig. 3L-1).
- (2) Remove nuts, washers and screws attaching hardtop enclosure to rear quarter panels.
- (3) Disconnect dome lamp, if equipped.
- (4) Remove hardtop enclosure from vehicle.

CAUTION: When removing hardtop enclosure, avoid damaging foam sealer installed between the hardtop enclosure and rear quarter panels.

INSTALLATION

- (1) Inspect tabular windshield seal, bonded to hardtop enclosure, for damage. Replace if necessary.
- (2) Carefully position hardtop enclosure on vehicle.

CAUTION: When installing the hardtop enclosure, avoid damaging foam sealer installed between the hardtop enclosure and rear quarter panels.

- (3) Install screws, washers and nuts attaching hardtop enclosure to rear quarter panels.

- (4) Connect dome lamp, if equipped.
- (5) Install screws attaching hardtop enclosure to windshield frame.

REPAIR

In the event of top damage, the following material will be required for use with these repair procedures:

- Paint Repair Kit (White)*
- Paint Repair Kit (Nutmeg)*
- Paint Repair Kit (Black)*
- Structural Adhesive (3M Brand or equivalent)

*The new paint repair kits are available from parts distribution centers. The paint repair kits consist of:

- Spatter Finish
- Base Coat
- Instruction Sheet

The following material will be required to repair the hardtop.

- Fiberglass mat or cloth
- Fiberglass resin and hardener
- Structural Adhesive (3M Brand or equivalent)
- Glazing Putty
- Aluminum Foil
- Plastic Spreader

Hole Repair

- (1) Use grinder to remove paint and to outline damaged area.
 - (a) Use grade 24 disc for initial grinding.

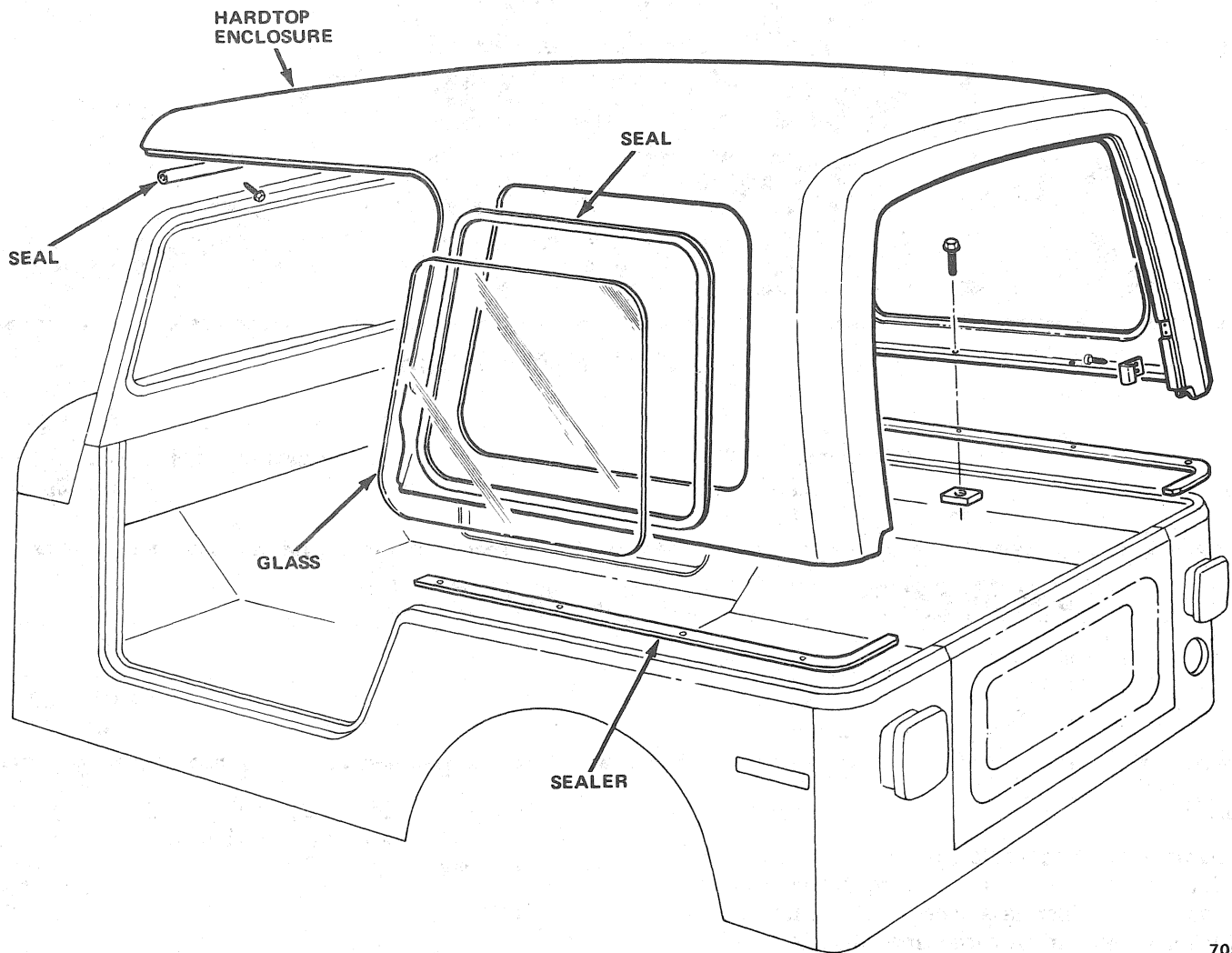

70508

Fig. 3L-1 Hardtop Enclosure Removal

(b) Follow up with grade 50 disc to prevent coarse scratches from showing up in final finish.

NOTE: *If there are any cracks extending from hole it will be necessary to stop-drill crack(s) using 1/8-inch drill bit.*

(2) Position fiberglass mat or cloth on repair area, cut out piece, allow one inch extension beyond damaged area.

(3) Clean damaged area.

(4) Place fiberglass on piece of aluminum foil.

(5) Pour fiberglass resin into clean container.

(6) Mix appropriate amount of hardener with resin, according to manufacturer's instructions.

(7) Apply resin mixture to both sides of fiberglass.

(8) Lay fiberglass and aluminum foil over repair area, on outside. With plastic spreader, use firm pressure to remove air bubbles. Allow resin to cure.

(9) Remove aluminum foil from cured resin.

(10) Use air file or hand file board for shaping cured fiberglass resin.

(a) Use grade 24 paper for initial shaping.

(b) For shaping and sanding contour in fiberglass resin, use grade 180 paper.

(11) Repeat above step on inside of top.

(12) Mix Structural Adhesive, according to manufacturer's instructions, apply liberally to repair area on inside and outside of top.

(13) Use air file or hand file board for shaping hardened Structural Adhesive.

(a) For initial shaping, use grade 24 paper.

(b) For shaping and sanding contours in Structural Adhesive, use grade 220 paper.

(c) For finish sanding, use grade 320 paper.

(14) If necessary, apply glazing putty over repair area, according to manufacturer's instructions.

(15) Finish sanding repair area with grade 360 paper.

(16) Apply base coat and color coat (refer to Paint Repair Procedure).

Broken Section Repair

(1) Use grinder to remove paint, from both sides, and to outline damaged area.

(a) Use grade 24 disc for initial grinding.

(b) Follow up with grade 50 disc to prevent coarse scratches from showing up in final finish.

(2) Bevel edges of break on both sides, using rotary file as shown in figure 3L-2.

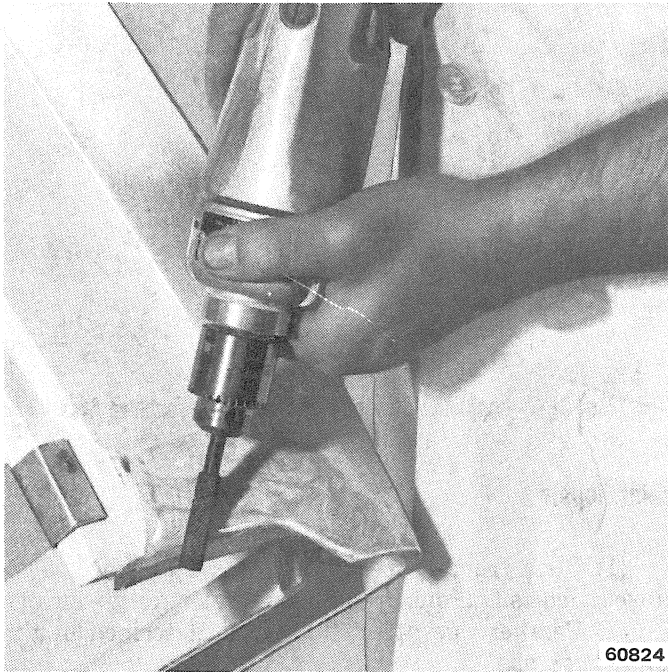

60824

Fig. 3L-2 Beveling Edges of Broken Piece with Rotary File

NOTE: Edges should be beveled on the inside and outside of the enclosure to ensure sufficient surface area for bonding.

(3) Clamp broken piece into place leaving 1/16-inch gap along break line.

(4) Mix Structural Adhesive, according to manufacturer's instructions, apply liberally to break as shown in figure 3L-3.

(5) Use air file or hand file board for shaping of hardened Structural Adhesive.

(a) For initial shaping, use grade 24 paper.

(b) For shaping and sanding contours in Structural Adhesive, use grade 36 or 40 paper.

(c) For finish sanding, use grade 80 paper.

(6) Apply base coat and color coat (refer to Paint Repair Procedure).

Fracture Repair

(1) Use grinder to remove paint, from both sides, and to outline damaged area.

(2) Stop-drill crack(s) using 1/8-inch drill bit as shown in figure 3L-4.

(3) Bevel edges of crack(s) on both sides, using rotary file.

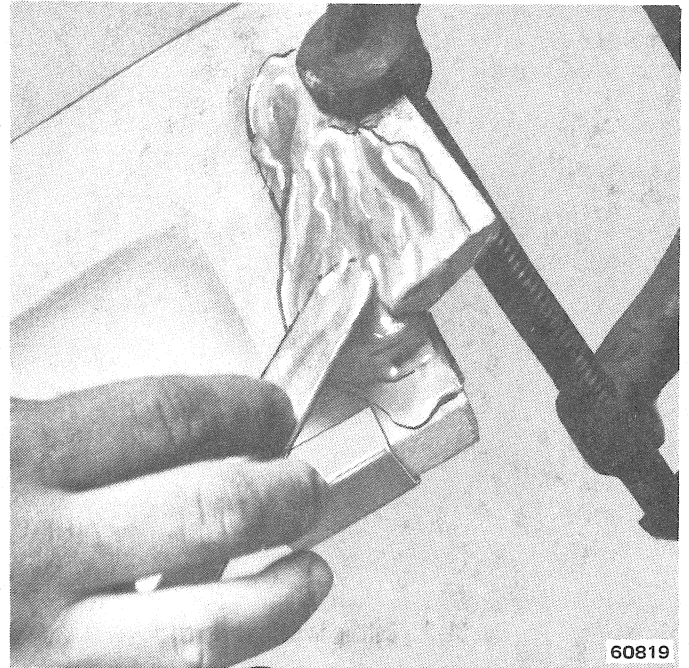

60819

Fig. 3L-3 Applying Structural Adhesive to Broken Piece and Enclosure

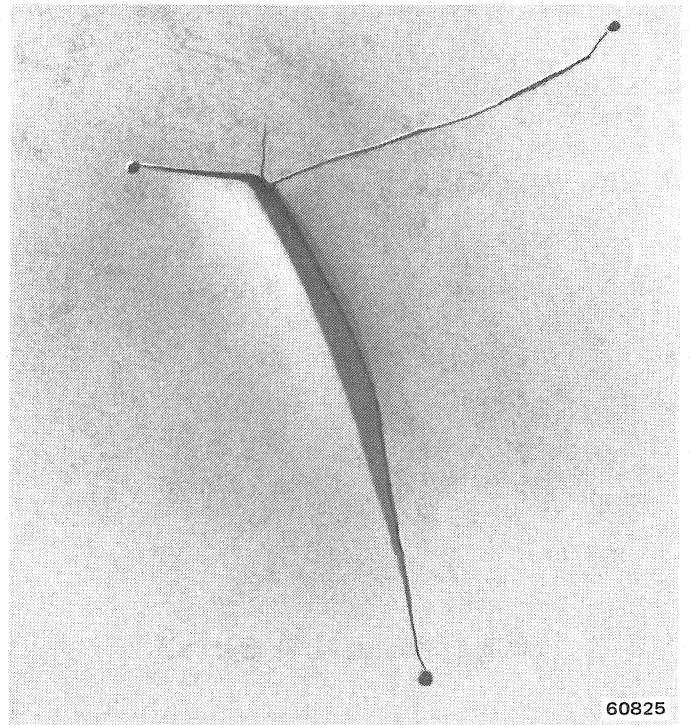

60825

Fig. 3L-4 Stop-Drilling Cracks

NOTE: Edges should be beveled on the inside and outside of the enclosure to ensure sufficient surface area for good bonding.

(4) Cut along length of crack(s) using hacksaw blade as shown in figure 3L-5.

NOTE: On crack(s) 6 inches or longer it is advisable to countersink pop rivets along length of crack(s) as shown in figure 3L-6.

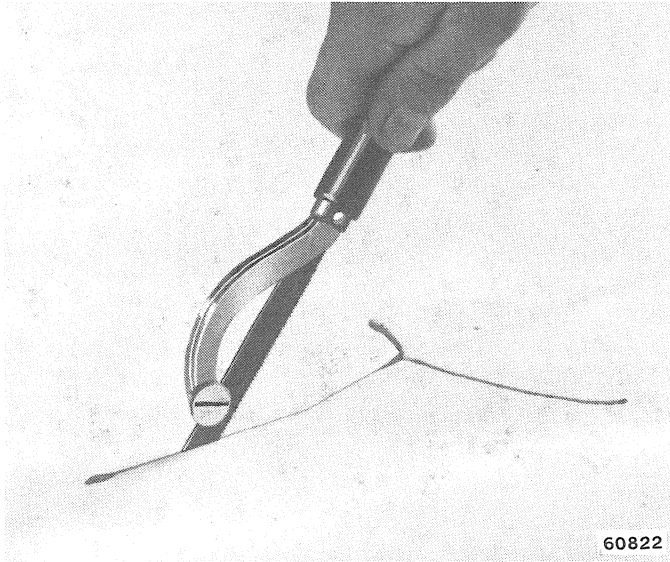

Fig. 3L-5 Cutting to Relieve Crack

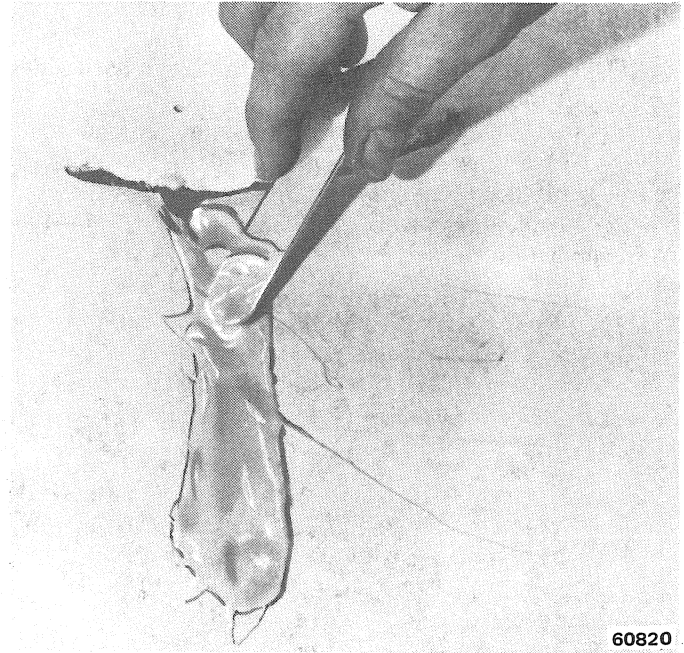

Fig. 3L-7 Applying Structural Adhesive to Fractured Area

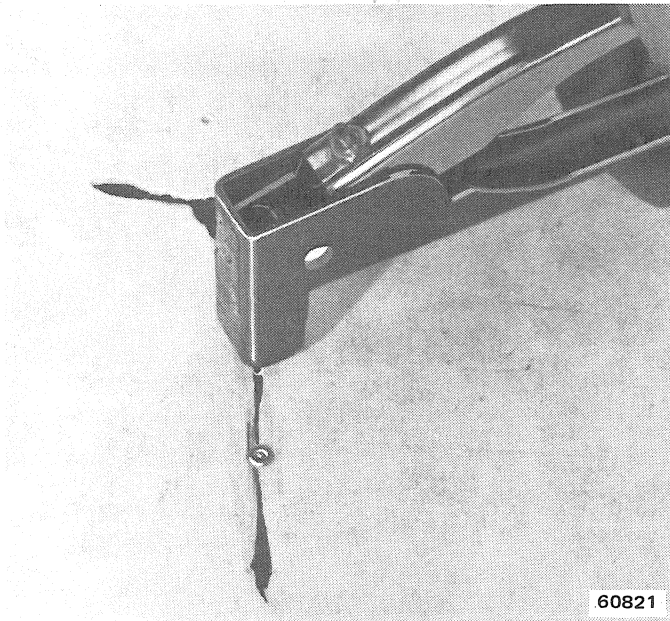

Fig. 3L-6 Installing Pop Rivets in Crack

Paint Repair

- (1) Clean repair area using wax and silicone remover such as DuPont Prep-Sol or Ditzler Acryli-Clean.
- (2) Featheredge affected area as described in the following steps:
 - (a) For rough featheredging, use grade 80 disc on random disc sander.
 - (b) For final featheredging, use grade 180 disc on random disc sander or 220 grade paper on hand sanding block.
- (3) Mix base coat same as any acrylic enamel paint using enamel reducer or lacquer thinner.

NOTE: One paint repair kit is sufficient to paint a complete top. Do not mix more paint than is necessary to cover the area being repaired. The spray equipment being used must be clean.

CAUTION: The solvents in this enamel will dissolve residual lacquers left in the cup or spray gun and may clog the gun or affect the finish surface.

WARNING: Vapor harmful—may cause lung irritation and allergic respiratory reaction. Use only with adequate fresh air ventilation.

- (4) Spray test panel and adjust spray gun as necessary.
- (5) Apply base coat to affected area and allow to dry to touch.

- (5) Mix Structural Adhesive, according to manufacturer's instructions, and apply liberally to crack(s) from inside and outside of enclosure as shown in figure 3L-7.
- (6) Use air file or hand file board and sanding block for shaping of Structural Adhesive.
 - (a) For initial shaping, use grade 24 paper.
 - (b) For shaping and sanding contours in Structural Adhesive, use grade 220 paper on sanding block.
 - (c) For finish sanding, use grade 320 paper.
- (7) Apply base coat and color coat (refer to Paint Repair Procedure).

(6) Empty spray gun.

NOTE: In most cases, it is not necessary to reduce the texture coat. However, if you cannot achieve the desired texture finish it may be necessary to reduce slightly.

(7) Stir texture paint thoroughly.

(8) Spray test panel and adjust spray gun to obtain desired texture finish.

NOTE: Paint must be applied in the desired texture finish. This paint does not wrinkle or change texture during drying. In most cases, it is necessary to use a

pressure-feed type spray gun to produce a coarse enough texture.

(9) Spray affected area with texture color coat, starting in center and working to outside edges.

(10) Empty spray gun and fill cup with reducer.

(11) Spray reducer on edges of painted area to eliminate overspray and blend in repair.

(12) Bake for 30 minutes at temperature not to exceed 140°F or let air dry for 24 hours.

(13) Clean spray equipment thoroughly.

NOTE: Equipment must be cleaned immediately after use.

MANUALLY OPERATED SUN ROOF

	Page		Page
Cherokee-Wagoner	3L-6	General	3L-5
CJ Models	3L-5		

GENERAL

A manually operated sun roof as shown in figure 3L-8 is available on CJ models equipped with the hardtop option. The sun roof can be opened and locked in place or removed entirely. To remove the sun roof glass, pull the retaining rod and disconnect the latch handle assembly. Tilt the glass to an angle greater than 60 degrees, release bayonets from retainers, and remove glass. Safely stow the glass in storage compartment.

CJ MODELS

Sun Roof Glass

The bayonets and handle assembly are retained by screws with circular water seals, and retaining nuts with washers.

Frame

Removal

- (1) Remove glass assembly.
- (2) Remove frame screw cover.
- (3) Remove attaching screws from clamp ring.
- (4) Remove clamp ring.
- (5) Push frame assembly outward and remove frame.

Installation

(1) Clean sun roof frame and roof panel contact surfaces using 3M General Purpose Adhesive Cleaner and Wax Remover, or equivalent.

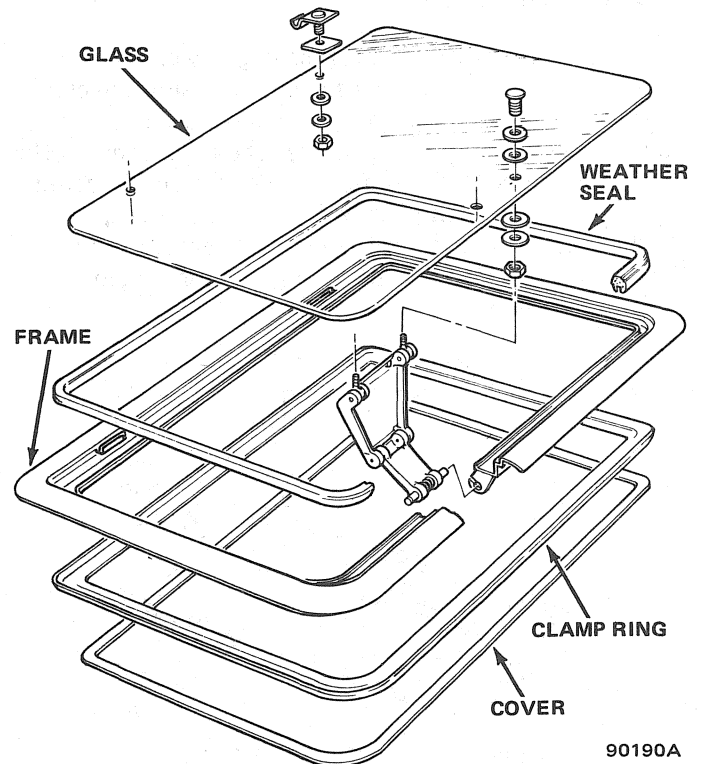

Fig. 3L-8 Sun Roof Component—CJ Models with Hardtop

(2) Apply bead of 3M Clear Super Silicone Sealer, or equivalent, on surface of outer roof panel, 1/8-inch from edge of opening.

(3) Install sun roof frame in roof panel.

(4) Position clamp ring over sun roof frame.

(5) Install attaching screws.

- (6) Wipe excessive sealer from roof panel.
- (7) Install screw cover.
- (8) Install glass assembly.

Glass Frame Weatherseal

To remove the glass frame weatherseal use 3M Release Agent, or equivalent. Apply one application and allow several minutes for penetration. Apply a second application and allow several minutes for the adhesive bond to soften. Use a wooden wand or fiber stick to pry the weatherseal from sun roof glass frame. Clean weatherseal and adhesive residue from the frame channel with 3M General Purpose Adhesive Cleaner, or equivalent.

To install the replacement weatherseal, first apply a thin bead of 3M Super Weatherstrip Adhesive, or equivalent, to the glass frame locating channel. Using wooden wand or fiber stick, install weatherseal in sun roof glass frame. Apply a thin film of petroleum jelly on seal-to-glass contact surfaces.

CHEROKEE-WAGONEER

A manually operated sun roof (fig. 3L-9) is available for Cherokee and Wagoneer models. The sun roof can be opened and locked in place or removed entirely. To remove the sun roof glass, compress the latch arms at the frame bracket and disconnect the latch from the frame. Tilt the glass to an angle greater than 60 degrees, release the bayonets from the retainers and remove the glass. Safely stow the glass in the storage compartment.

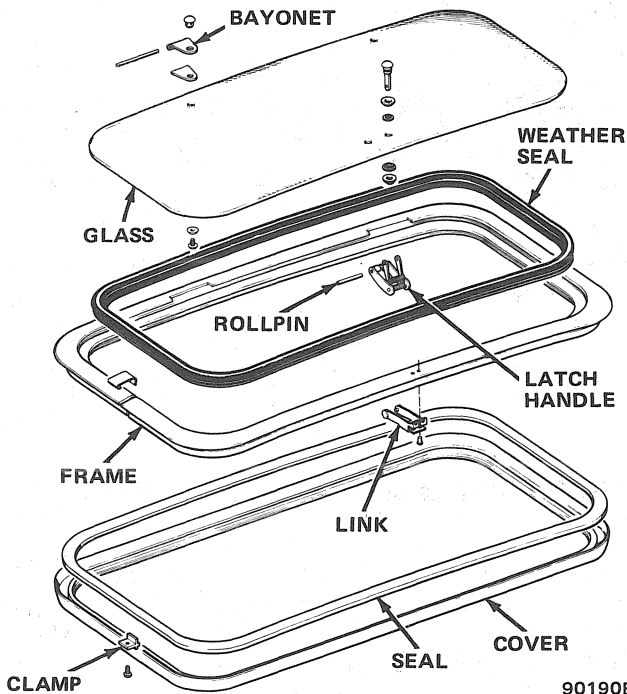

Fig. 3L-9 Sun Roof Components—Cherokee-Wagoneer Models

Glass Frame Weatherseal

Removal

- (1) Remove glass assembly.
- (2) Apply 3M Release Agent, or equivalent, to weatherseal and allow several minutes for penetration.
- (3) Apply second application and allow several minutes for adhesive bond to soften.
- (4) Remove seal from frame.
- (5) Remove all residue from frame with 3M General Purpose Adhesive Remover, or equivalent.

Installation

- (1) Apply thin bead of 3M Super Weatherstrip Adhesive, or equivalent, in channel.
- (2) Install weatherseal in channel.
- (3) Apply thin film of petroleum jelly to seal and glass contact surfaces.
- (4) Install glass assembly.

Frame

Removal

- (1) Remove frame cover (fig. 3L-9).
- (2) Remove headliner as described in Chapter 3P.
- (3) Remove sun roof glass.
- (4) Remove frame attaching screws and clamps.
- (5) Remove frame assembly.

Installation

- (1) Clean sun roof frame and roof panel contact surfaces using 3M General Purpose Adhesive Cleaner and Wax Remover, or equivalent.
- (2) Apply bead of 3M Clear Super Silicone Sealer, or equivalent, on surface of outer roof panel, 1/8-inch from edge of opening.
- (3) Install sun roof frame in roof panel.

CAUTION: Do not install retainers on roof panel indentations. Tighten attaching screws in a criss-cross pattern.

- (4) Install sun roof clamps and attaching screw. Tighten to 7 to 9 inch-pounds (0.79 to 1.02 N•m) torque.
- (5) Wipe excessive sealer from roof panel.
- (6) Install sun roof glass.

NOTE: Check sun roof for waterleaks.

- (7) Install headliner as described in Chapter 3P.
- (8) Install frame cover.

POWER SUN ROOF — WAGONEER LIMITED

	Page		Page
Cable and Side Track	3L-9	Motor Clutch Adjustment	3L-12
General	3L-7	Power Sun Roof Housing	3L-10
Glass Panel	3L-7	Power Sun Roof Motor	3L-12
Glass Panel Height Adjustment	3L-12	Power Sun Roof Switch Removal/Installation	3L-12
Glass Panel Parallel Alignment	3L-12	Sunscreen	3L-7
Halo Assembly	3L-7	Vinyl Roof	3L-10
Headlining	3L-11	Vinyl Top Repair	3L-14
Manual Operation of Glass Panel	3L-13		

GENERAL

A power sun roof is available on Wagoneer Limited models (fig. 3L-10). The sun roof features a sliding glass panel operated by an electric motor and a manually operated sun screen. A nylon knit, one-piece headliner with bonded foam backing and a padded vinyl roof are standard with the optional sun roof.

The electric motor that operates the sliding glass panel is activated by a two-position switch mounted in the windshield header. The electric motor itself is mounted in the forward portion of the sun roof housing assembly. Electrical feed to the motor is through the A/C terminal of the fuse panel. Circuit protection is provided by the A/C terminal fuse and by a 20 amp, in-line fuse in a harness wire located just below the left A-pillar.

An additional feature of the sun roof is the ability to close the sliding glass panel manually if an electrical power failure should occur. A cranking tool is provided with the sun roof for this purpose.

A rubber drain hose is used at each corner of the sun roof housing. These hoses remove any water that may bypass the weatherstrip seal surrounding the roof opening. The forward hoses are routed downward through the A-pillars. The rearward hoses are routed downward through the D-pillars.

HALO ASSEMBLY

Removal

- (1) Open glass panel partially and remove halo assembly attaching screws (fig. 3L-11).
- (2) Grasp center of halo assembly and pull assembly downward to disengage front tabs from track.
- (3) Close glass panel fully, slide halo assembly forward, and remove assembly from vehicle (fig. 3L-12).

Installation

- (1) Close glass panel and position rear portion of halo assembly on glass panel.

- (2) Open glass panel partially.
- (3) Install halo assembly attaching screws.

GLASS PANEL

Removal

- (1) Remove halo assembly. Refer to Halo Assembly Removal.
- (2) Close glass panel and remove outboard screws from front guide shoe assemblies (fig. 3L-13). Then loosen inboard screws and rotate guide shoes to disengage slide portion from track.
- (3) Release rear slide tension springs by rotating them to inboard position.
- (4) Remove screws attaching rear guide shoes and retainers to tabs in glass panel and remove retainers.
- (5) Working from outside of vehicle, raise front of glass panel and slide panel forward and out of vehicle.

Installation

- (1) Position glass panel in vehicle.
- (2) Install rear guide shoes and retainer brackets on glass panel and install guide shoe and retainer bracket attaching screws.
- (3) Install rear slide tension springs (fig. 3L-13).

NOTE: Be sure the spring is positioned under the spring lock roller.

- (4) Engage slide portion of front guide shoe assemblies in track and install guide shoe attaching screws.
- (5) Install halo assembly. Refer to Halo Assembly Installation.

SUNSCREEN

Removal

- (1) Remove halo assembly and glass panel. Refer to Halo Assembly Removal and Glass Panel Removal procedures.
- (2) Open sunscreen fully.

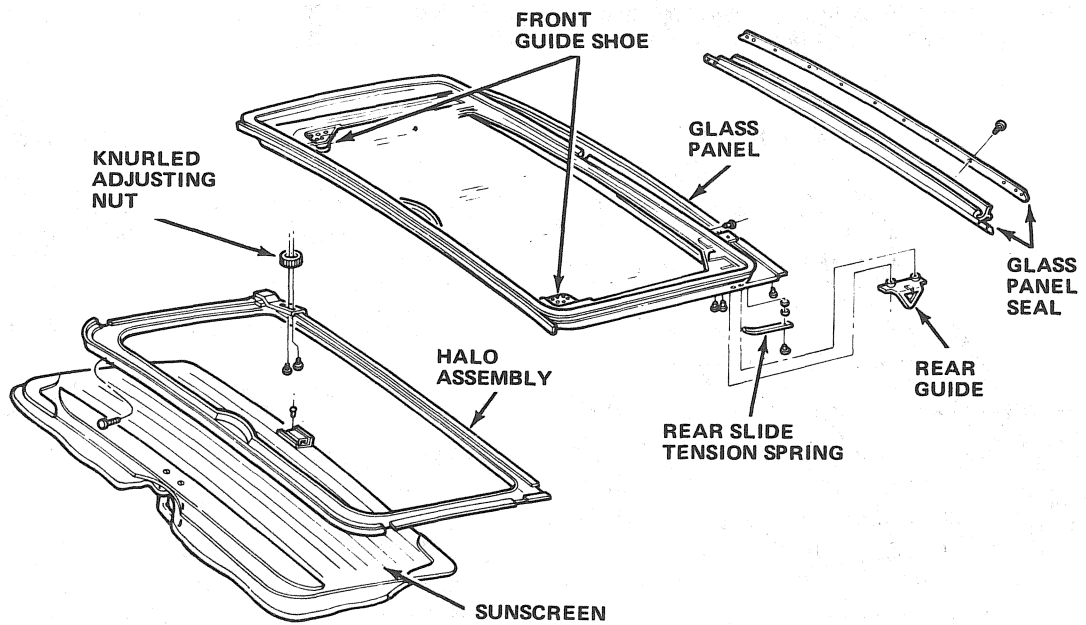

81106F

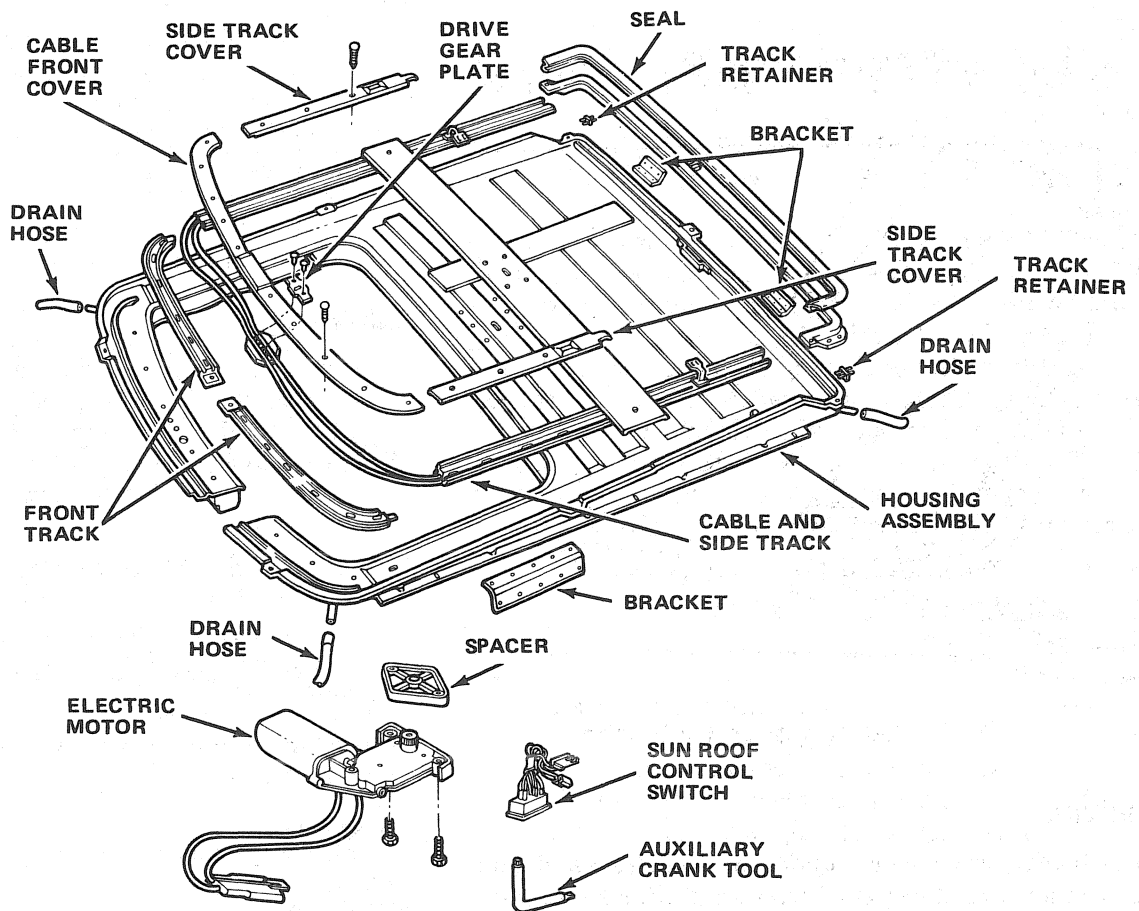

81106E

Fig. 3L-10 Power Sun Roof Assembly

(3) Working from outside of vehicle, push sunscreen upward at center of screen and slide screen forward and upward to remove it (fig. 3L-14).

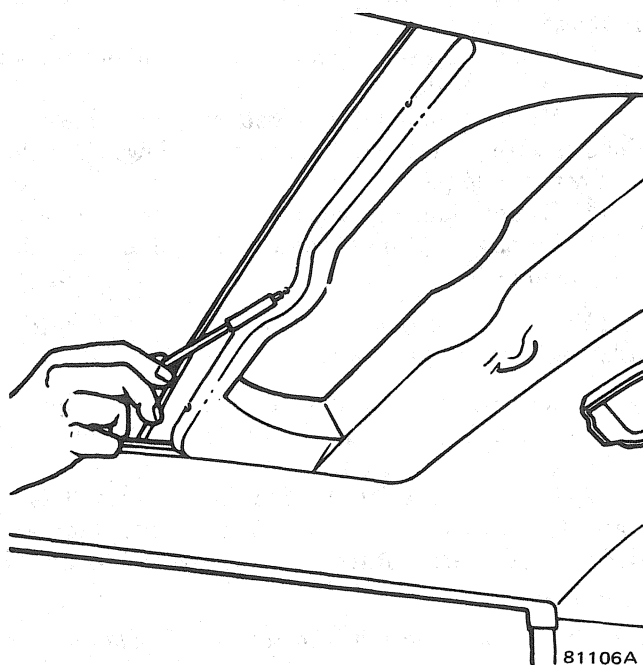

Fig. 3L-11 Removing/Installing Halo Assembly Attaching Screws

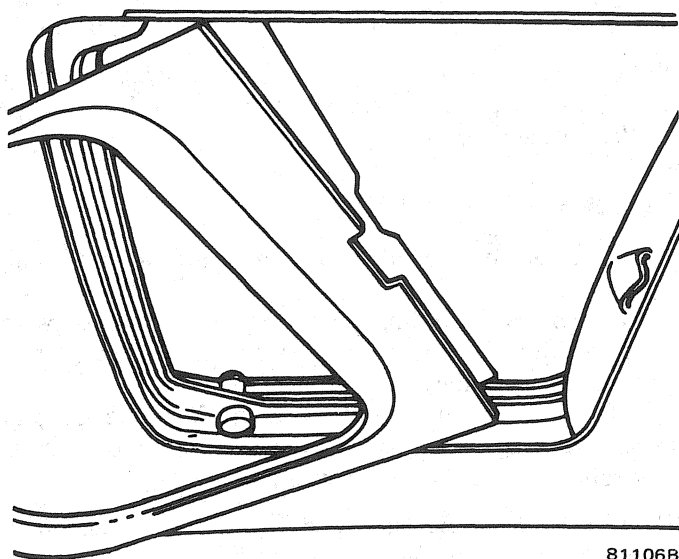

Fig. 3L-12 Removing/Installing Halo Assembly

Installation

(1) Working from outside of vehicle, curve sunscreen upward at center of screen and slide screen rearward and downward into sun roof opening (fig. 3L-14).

(2) Install glass panel and halo assembly. Refer to Glass Panel Installation and Halo Assembly Installation procedure.

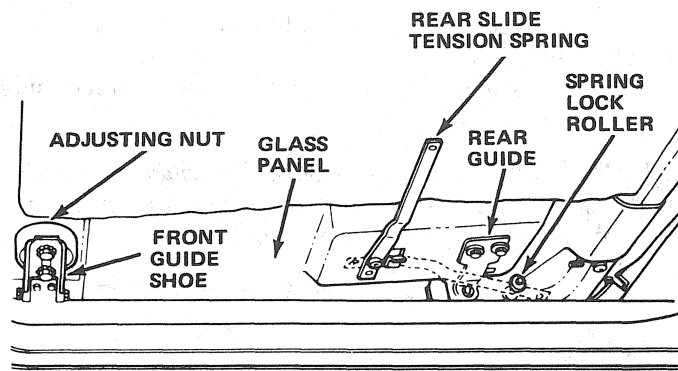

Fig. 3L-13 Front Guide Shoe and Rear Tension Spring

CABLE AND SIDE TRACK

Removal

- (1) Remove halo assembly, glass panel and sunscreen. Refer to removal procedures.
- (2) Remove screws that attach cable front cover and remove cover (fig. 3L-10).
- (3) Remove drive gear plate.
- (4) Remove side track cover screws and remove side track cover.

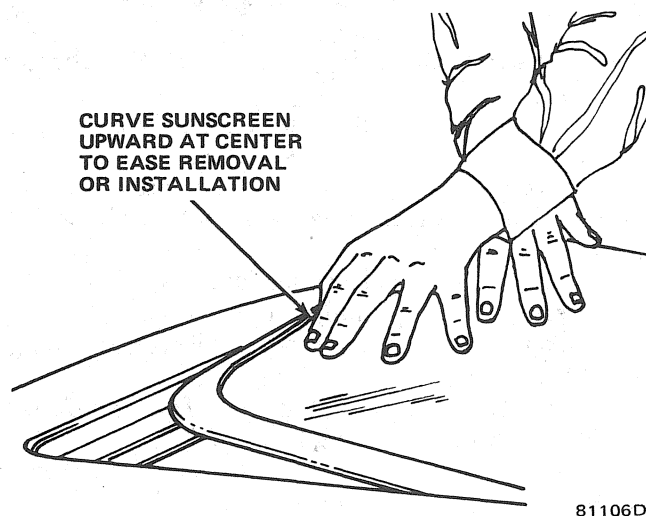

Fig. 3L-14 Sunscreen Removal/Installation

(5) Disengage cable from front track and motor gear and remove cable by pulling it upward and outward.

NOTE: It may be necessary to reposition the front cable guide before the cable can be removed from the track.

(6) Lift side track upward and remove side track.

Installation

(1) Position side track in sun roof housing. Be sure track retainer is seated in hole at rear of housing (fig. 3L-10).

(2) Slide cable assembly into side track and install cover on side track.

(3) Pull cable until rear guide shoe contacts side track cover.

NOTE: *If both cables have been disengaged from the motor gear, be sure both rear guide shoes are in contact with the side track covers before proceeding.*

(4) Position cables in front track and engage cables with teeth of drive gear.

(5) Install drive gear plate.

CAUTION: *Do not operate the motor at this time as the cables could be damaged.*

(6) Install cable front cover.

(7) Install sunscreen, glass panel and halo assembly. Refer to installation procedures outlined in this section.

POWER SUN ROOF HOUSING

Removal

(1) Remove halo assembly, glass panel and sunscreen. Refer to removal procedures outlined in this section.

(2) Remove headlining. Refer to Headlining Removal.

(3) Disconnect ground wire at right A-pillar and move wire away from housing assembly.

(4) Disconnect sun roof switch from motor harness.

(5) Disconnect drain tubes from sun roof housing (fig. 3L-10).

(6) Remove housing attaching nuts.

(7) Remove shims, if equipped.

(8) Support housing and remove housing attaching hardware from brackets.

(9) Lower housing assembly away from reinforcement ring and remove housing from vehicle.

Installation

(1) Position housing assembly in vehicle.

(2) Raise and support housing on reinforcement ring.

(3) Install shims, if equipped, and tighten housing attaching hardware.

(4) Connect drain tubes to housing assembly (fig. 3L-10).

(5) Connect sun roof switch to motor harness.

(6) Position ground wire on housing assembly and connect wire to right A-pillar.

(7) Install headlining. Refer to Headlining Installation.

(8) Install sunscreen, glass panel and halo assembly. Refer to Installation Procedures outlined in this section.

VINYL ROOF

Removal

(1) Remove moulding clips and remove mouldings around vinyl roof.

(2) Remove all sealing material around openings to expose vinyl top edges.

(3) Mask cowl top, sides and rear of vehicle, and windows with paper. Insert paper in windows, then close windows to hold paper in place.

(4) Remove luggage rack.

(5) Loosen vinyl material at front pillars and along windshield header.

NOTE: *If may be easier to remove the vinyl material and padding simultaneously.*

(6) Remove material and sealer from drip rail. Pry sealer loose using screwdriver or other suitable tool if necessary.

(7) If vinyl material and padding is difficult to remove, soak adhesive next to fabric using rag dampened with 3M General Purpose Adhesive Cleaner or equivalent.

NOTE: *It is not necessary to remove the old vinyl top adhesive. However, it is important that the roof surface be smooth and free of irregularities to prevent highlighting after a new cover is installed.*

(8) Remove vinyl material from foam padding using 3M General Purpose Adhesive Cleaner, or equivalent.

WARNING: *Always use rubber gloves when working with solvents and be sure the work area is wellventilated.*

Installation

(1) Remove all dust and foreign material from roof panel.

(2) Position padding on roof panel and cut away foam padding at sun roof opening and luggage rack attaching screw holes.

(3) Remove paper backing from foam padding to expose padding adhesive and bond padding to roof panel. Use roller or soft cloth to ensure positive bond.

NOTE: *Be sure the foam padding is smooth and free from any irregularities to prevent highlighting after a new cover is installed.*

(4) Mark centerline of roof panel above windshield and rear window openings.

(5) Align center of vinyl cover with centerline mark above windshield and rear window.

(6) Secure cover to pinch weld flange at centerline locations with tape.

(7) Check cover for alignment at both sides and at roof extension panels.

(8) Fold cover in half at centerline.

(9) Apply smooth, even coat of 3M Vinyl Trim Adhesive or equivalent to 15-inch wide strip of one side of foam padding and to vinyl cover. Start at center when applying adhesive and work from front to rear.

NOTE: Allow the adhesive applied to the vinyl material and foam padding to dry until it is tacky to the touch.

(10) Bond cover to foam padding using a roller or soft cloth to ensure positive bond and to eliminate air pockets. Bond cover by starting at centerline and working toward side.

NOTE: To remove wrinkles caused by folding, keep the cover fabric taut while installing it.

(11) Apply adhesive to remainder of cover and foam padding and in drip moulding at side of cover being installed. Allow adhesive to dry until tacky.

(12) Apply smooth, even coat of adhesive to 15-inch wide strip of foam padding and to vinyl cover on opposite side of vehicle. Start at center and work from front to rear when applying adhesive. Allow adhesive to dry until tacky.

NOTE: When applying the cover to the foam padding, always work from the center to the outside to eliminate air pockets to ensure positive bonding.

(13) Brush adhesive onto cover, ledge of windshield, and rear window opening. Allow adhesive to dry until tacky before bonding.

(14) Work vinyl cover into crease line areas around roof using smooth fiber stick.

(15) Trim excess cover material from around drip rails, windshield and rear window.

(16) Trim vinyl material around sun roof opening and luggage rack attaching screw holes.

(17) Brush adhesive onto cover and ledge of sun roof opening. Allow adhesive to dry until tacky before bonding.

(18) Position and work vinyl cover into sun roof opening using smooth fiber stick.

(19) Install luggage rack.

(20) Apply bead of 3M Super Silicone Sealer (black preferred) or equivalent along top of windshield rubber weather strip and vinyl cover.

NOTE: It may be necessary to apply sealer to the drip rails also.

(21) Remove excess sealer using 3M General Purpose Adhesive Cleaner or equivalent and remove all masking tape and paper.

(22) Install mouldings and clips.

HEADLINING

Removal

(1) Remove sun visors, escutcheons and center support.

(2) Remove windshield moulding and end caps.

(3) Remove sun roof switch and disconnect switch wires.

(4) Remove sun roof opening trim welt and remove motor cap.

(5) Spray 3M Release Agent or equivalent, across headlining at windshield and around sunroof opening. Allow several minutes for release agent penetration.

CAUTION: When removing the headlining, use care to avoid separating the foam backing from the fabric. If the fabric begins to separate from the backing, make a second application of the release agent.

(6) Remove headlining from roof panel and sun roof opening.

(7) Remove headlining from side retainers.

(8) Remove lens from dome lamp. Remove screws attaching lamp to sun roof housing and remove lamp.

(9) Remove coat hooks.

(10) Remove lens from cargo lamp, then remove screws attaching cargo lamp to roof bow and remove lamp and switch.

(11) Remove tailgate opening moulding and end caps.

(12) Spray 3M Release Agent, or equivalent, across headlining at tailgate opening moulding. Allow several minutes for release agent penetration.

CAUTION: When removing the headlining, use care to avoid separating the foam backing from the fabric. If the fabric begins to separate from the backing, make a second application of release agent.

(13) Remove headlining from tailgate opening.

(14) Remove headlining from side retainers and slide headliner rearward and out of headlining brackets.

(15) Remove headlining from vehicle through tailgate opening.

Installation

(1) Install headlining in vehicle through tailgate opening. Insert headlining in headlining brackets and slide headlining forward.

(2) Spray 3M General Trim Adhesive, or equivalent, across at roof panel at tailgate opening.

(3) Attach headlining to roof panel at tailgate opening and install tailgate opening moulding and end caps.

(4) Pull headlining forward. Install headlining up to coat hook locations along both sides using Installer Tool J-2772-C.

(5) Connect and install cargo lamp and lens.

(6) Connect and install cargo lamp switch.

(7) Spray 3M General Trim Adhesive, or equivalent, on sun roof opening flange.

(8) Install coat hooks.

(9) Pull headlining forward and attach it to sun roof opening flange.

(10) Install sun roof opening trim welt.

(11) Connect and install dome lamp and lens.

(12) Place strip of masking tape across top of windshield at roof panel.

(13) Spray 3M General Trim Adhesive, or equivalent, on roof panel along top of windshield.

(14) Using sun visor holes as guides, pull headlining forward and attach it along windshield.

(15) Install headlining along both sides using Installer Tool J-2772-C.

(16) Connect and install sun roof switch.

(17) Install windshield moulding and end caps, and motor cap.

(18) Install sun visors, escutcheons and center support.

(19) Remove masking tape.

POWER SUN ROOF SWITCH REMOVAL/INSTALLATION

(1) Pull switch downward and disconnect switch wires (fig. 3L-10).

(2) Connect switch wires and install switch in switch opening.

POWER SUN ROOF MOTOR

Removal

(1) Open sun roof glass panel; then disconnect battery negative cable.

(2) Remove sun visors, escutcheons, center support, and windshield moulding and end caps.

(3) Remove sun roof switch and motor cap.

(4) Spray 3M Release Agent, or equivalent, across headlining at windshield. Allow several minutes for release agent penetration.

CAUTION: *When removing the headlining, use care to avoid separating the foam backing from the fabric. If the fabric begins to separate from the backing, make a second application of the release agent.*

(5) Pull front edge of headlining downward.

(6) Remove motor mounting screws and remove motor.

Installation

(1) Position motor in housing and install motor mounting screws.

(2) Place strip of masking tape across top of windshield at roof panel.

(3) Spray 3M General Trim Adhesive, or equivalent, on roof panel along top of windshield.

(4) Pull headlining forward and attach it along windshield. Use sun visor holes as guides when attaching headlining.

(5) Connect wires to sun roof switch and install switch and motor cap.

(6) Install sun visors, escutcheons, windshield trim moulding and end caps, and center support.

(7) Connect battery negative cable, and check sun roof operation.

NOTE: *If the motor slips and does not open and close the glass panel, the motor clutch located in the gear portion of the motor may have to be adjusted. Refer to Motor Clutch Adjustment.*

MOTOR CLUTCH ADJUSTMENT

(1) Remove motor cap to gain access to adjusting screw. Cap is located in headlining just above, and at center of windshield.

(2) Loosen clutch plate adjusting screw jamnut using deep socket.

(3) Tighten adjusting screw to 50 inch-pounds (5.6 N•m) torque.

(4) Tighten jamnut and install motor cap.

GLASS PANEL PARALLEL ALIGNMENT

CAUTION: *Do not operate the electric motor while the glass panel or cables are removed from the track as cable damage could occur.*

(1) Open glass panel approximately 1/4 to 1/2 inch.

(2) Determine how much forward edge of glass panel is out of parallel with forward edge of opening in roof panel and note variation.

(3) Open panel approximately 8 inches to gain access to cable and drive gear mechanism.

(4) Remove cable front cover and drive gear plate.

(5) Remove one cable from track.

(6) Move one side of glass panel slightly fore or aft as required to obtain parallel alignment with forward edge of roof panel opening (fig. 3L-15).

(7) Install cable in front track and insert cable in drive gear teeth.

(8) Install drive gear plate and cable front cover.

(9) Position glass panel approximately 1/4 inch from fully closed position.

(10) Check parallel alignment. Repeat steps (2) through (9) to obtain proper alignment if necessary.

GLASS PANEL HEIGHT ADJUSTMENT

Adjusting Front of Panel

(1) Remove halo assembly. Refer to Halo Assembly Removal.

(2) Loosen front guide shoe attaching screws (fig. 3L-16).

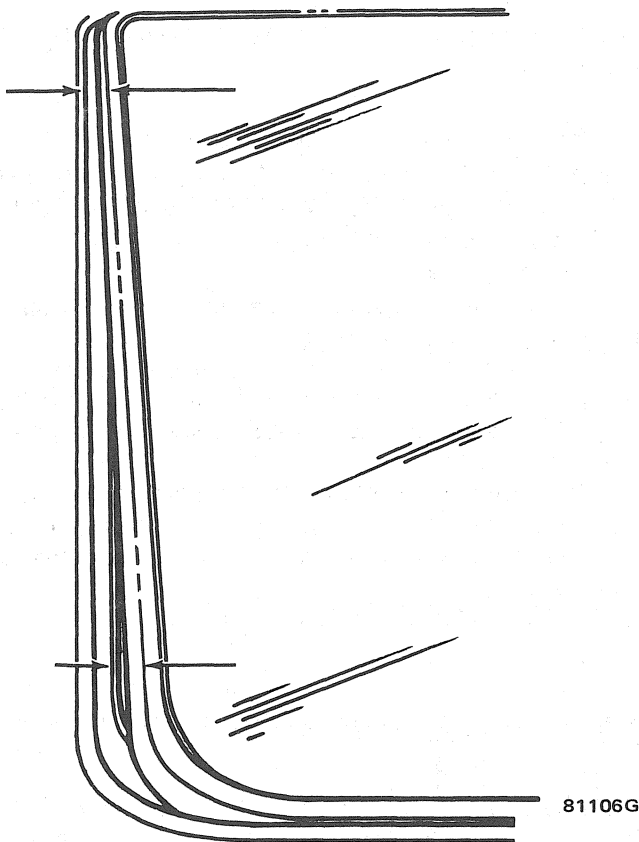

Fig. 3L-15 Glass Panel Parallel Alignment

(3) Turn knurled nut on each front guide shoe clockwise to lower glass panel or counterclockwise to raise panel and obtain desired height adjustment (fig. 3L-16).

(4) Tighten front guide shoe attaching screws to 20 inch-pounds (2.3 Nm) torque after adjusting panel height.

CAUTION: Do not adjust the glass panel too high as it could be damaged when the panel is opened or closed.

(5) Check glass panel alignment and operation in open and closed positions. Repeat steps (2) through (4) to obtain proper height if necessary.

(6) Install halo assembly. Refer to Halo Assembly Installation.

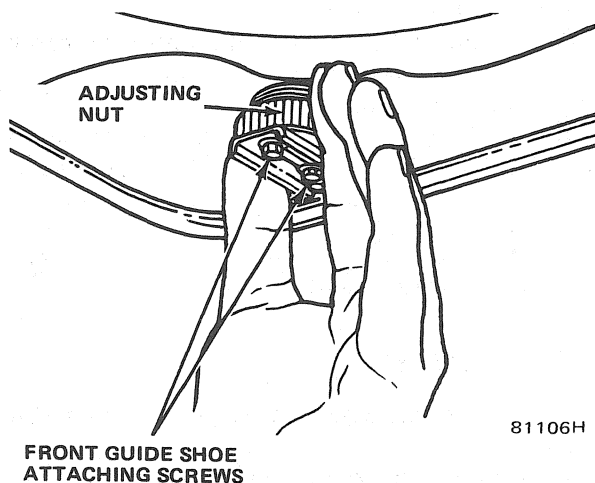

Fig. 3L-16 Glass Panel Front Height Adjustment

Adjusting Rear of Panel

(1) Remove halo assembly. Refer to Halo Assembly Removal.

(2) Release rear slide tension spring and rotate spring to inboard position (fig. 3L-13).

(3) Loosen rear slide adjuster nut (fig. 3L-17) and raise or lower panel as required to obtain desired adjustment.

(4) Tighten rear slide adjuster nut to 30 inch-pounds (3.3 Nm) torque after completing adjustment.

(5) Install halo assembly. Refer to Halo Assembly Installation.

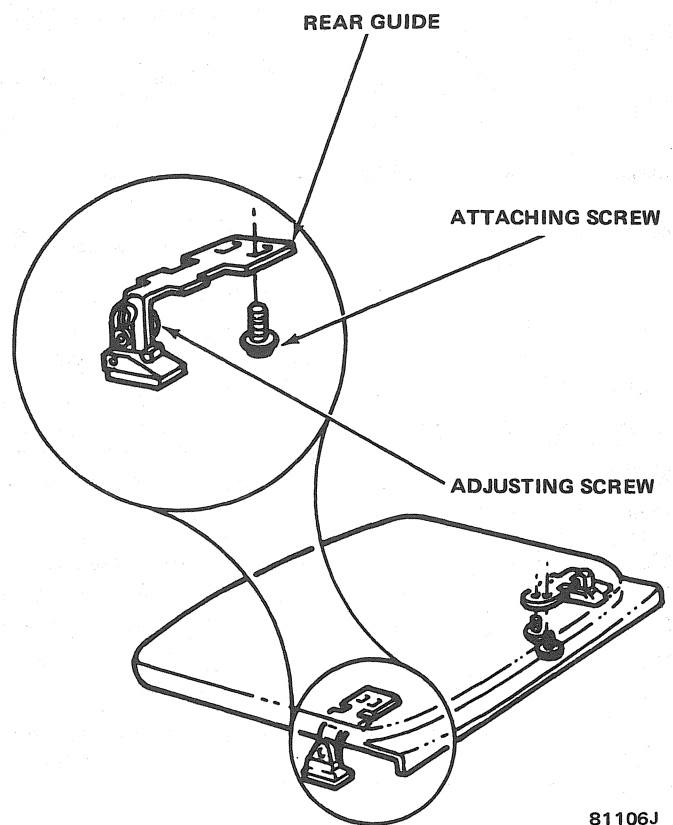

Fig. 3L-17 Glass Panel Rear Height Adjustment

MANUAL OPERATION OF GLASS PANEL

If an electrical malfunction should ever occur, the glass panel can be opened or closed manually as follows:

(1) Remove small round motor cap located in center of windshield header near front edge of sun roof opening. Cap removal will provide access to motor driveshaft.

(2) Remove screw in driveshaft using flat bladed screwdriver or cranking tool blade end (located in glovebox).

(3) Rotate motor driveshaft using cranking tool. Rotate driveshaft clockwise to close glass panel, or counter-clockwise to open panel.

(4) Install screw in driveshaft and install access plug in windshield header after opening/closing glass panel.

VINYL TOP REPAIR

Bulges or Blisters

Bulges or blisters in the vinyl top indicate poor bonding or trapped air. They can be eliminated by piercing the bulge or blister to expel the air. Heat the area for 10 to 15 seconds with Heat Gun J-25070, held 10 to 15 inches from the material.

Immediately press and hold vinyl material firmly against foam padding and metal with a felt pad or roller

until vinyl cover cools. Do not rub vinyl. Rubbing will result in a polished area.

Wrinkles

Minor wrinkles in the vinyl top material may be removed with the application of moist heat as follows:

(1) Wash vinyl top surface thoroughly using AMC Vinyl Cleaner, or equivalent.

(2) Set heat control or household-type flat iron to warm.

(3) Dampen a clean cloth with clean water and apply it over wrinkled area.

(4) With iron at proper operating temperature, move iron continuously over dampened cloth until wrinkle is removed.

Maintain pressure on vinyl top material until material cools.

CAUTION: Apply pressure to the vinyl top material only. Do not rub the vinyl top repair area as this could impair the finish of the vinyl.

LUGGAGE RACK

	Page		Page
Adjustable End Rail	3L-14	Side Rail	3L-15
General	3L-14	Support	3L-14
Roof Slat	3L-15		

GENERAL

The luggage rack (fig. 3L-18) consists of side rails, adjustable end rails, end and center supports, and roof mounted slats. A spanner wrench, located in the vehicle glove box, facilitates securing the adjustable end rails.

The ends and center supports are attached to the roof top with rubber-coated well nuts and machine screws. The roof slats are attached with sheet metal screws.

Luggage rack components can be replaced without removing the entire assembly from vehicle.

SUPPORT

Removal

- (1) Remove screw(s) attaching support to side rail.
- (2) Remove attaching screws from support.

NOTE: Do not apply extreme pressure to support attaching screws during removal or installation as this may cause the well nuts to drop between the roof panel and headliner.

- (3) Remove support and gasket from roof.

Installation

- (1) Position support on side rail.
- (2) Position support and gasket on roof.
- (3) Coat screw threads with 3M Drip-Chek Sealer or equivalent, and install screws. Tighten screws to 28 inch-pounds (3 N•m) torque.
- (4) Install screw(s) attaching support to side rail.

ADJUSTABLE END RAIL

Removal

- (1) Remove screws attaching end supports to side rails.
- (2) Remove attaching screws from end supports.

NOTE: Do not apply extreme pressure to support attaching screws during removal or installation as this may cause the well nuts to drop between the roof panel and headliner.

- (3) Loosen adjustable end rail locknuts and remove adjustable end rail from side rails.

Installation

- (1) Position adjustable end rail in side rails.
- (2) Position end supports on side rails.

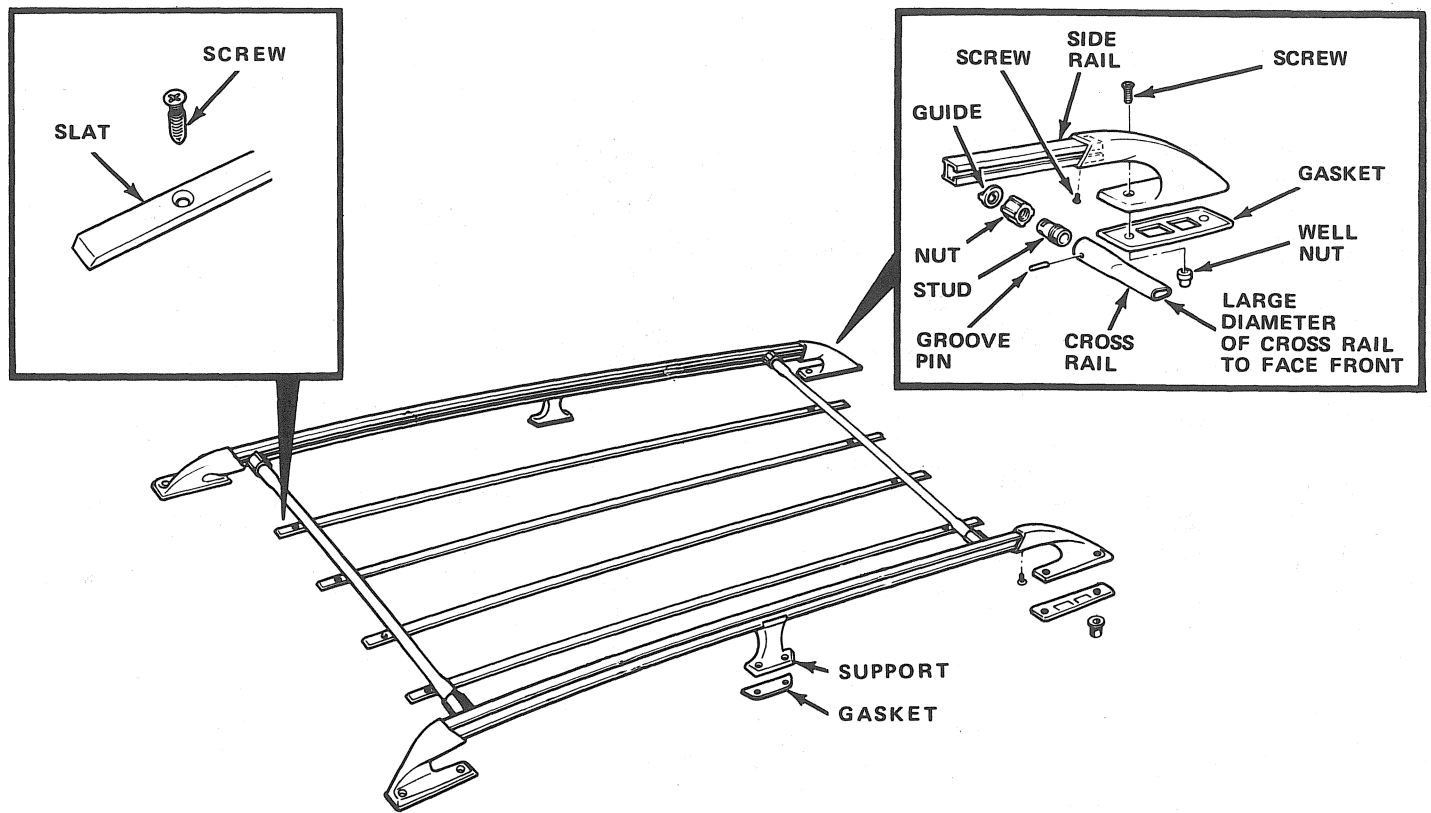

J41007

Fig. 3L-18 Luggage Rack—Cherokee-Wagoneer Models

- (3) Position end supports and gaskets on roof.
- (4) Coat screw threads with 3M Drip-Chek Sealer or equivalent, and install screws. Tighten screws to 28 inch-pounds (3 N•m) torque.
- (5) Install screws attaching end supports to side rails.
- (6) Tighten adjustable end rail locknuts.

SIDE RAIL

Removal

- (1) Remove screws attaching side rail to supports.
- (2) Remove screws attaching end support to roof.

NOTE: Do not apply extreme pressure to support attaching screws during removal or installation as this may cause the well nuts to drop between the roof panel and headliner.

- (3) Remove end support and side rail.

Installation

- (1) Position side rail on supports.
- (2) Position end support and gasket on roof.

- (3) Coat screw threads with 3M Drip-Chek Sealer or equivalent, and install screws. Tighten screws to 28 inch-pounds (3 N•m) torque.
- (4) Install screws attaching side rail to supports.

ROOF SLAT

Removal

- (1) Remove screws attaching roof slat to roof.
- (2) Remove roof slat.

Installation

CAUTION: Exercise care not to damage painted or vinyl surfaces.

NOTE: Surface must be clean and dry for roof slat to adhere.

- (1) Position roof slat on roof panel.
- (2) Install screws attaching roof slat to roof.

TOOLS

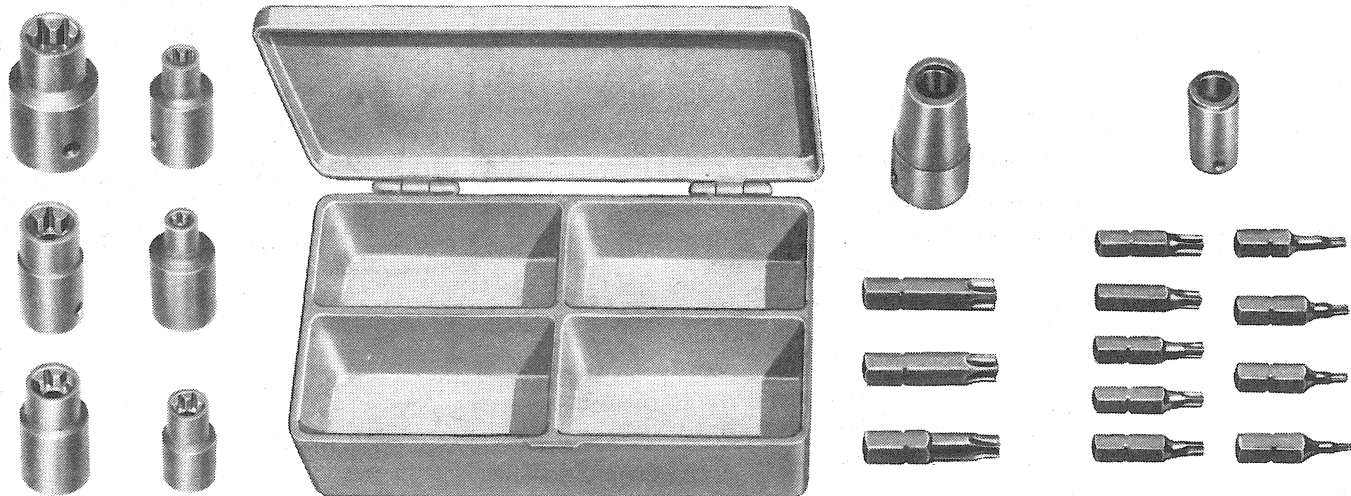

**J-25359-C
TORX BIT AND SOCKET SET**

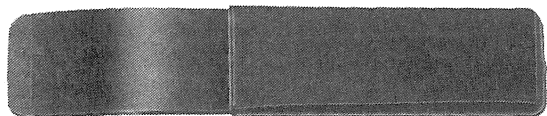

**J-2772-C
HEADLINING INSTALLER**

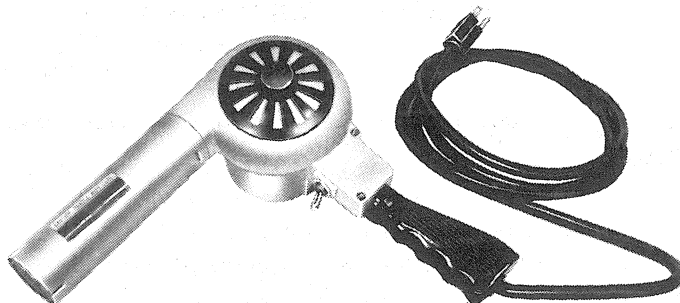

**J-25070
HEAT GUN**