

# LIFTGATES - TAILGATES

# 3H

## SECTION INDEX

	Page		Page
CJ-7 Liftgate	3H-1	CJ-7 Tailgate	3H-4
Cherokee-Wagoneer Tailgates	3H-5	Townside Truck Tailgate	3H-13
CJ-5 Tailgate	3H-4	Sport Truck Tailgate	3H-13

## CJ-7 LIFTGATES

	Page		Page
Hinge System	3H-3	Lock System	3H-2
Liftgate Adjustment	3H-3	Sealing System	3H-1
Liftgate Installation	3H-3	Support System	3H-3
Liftgate Removal	3H-3	Window System	3H-1

### SEALING SYSTEM

#### Rubber Sealer

The liftgate rubber sealer is made of molded latex foam with a smooth rubber skin on the outside.

Plastic retainers are used to retain the rubber sealer to the liftgate. Barbs on the retainers depress when inserted in the holes and spread when fully inserted.

#### Maintenance of Rubber Sealers

Cold weather may cause the rubber sealer to harden and lose resiliency. This may cause the liftgate to loosen in its opening, resulting in noise. When servicing, use a dampened cloth to clean rubber sealer. Clean dirt from all points where rubber sealer contacts the molded top and tailgate. Apply AMC Silicone Lubricant, or equivalent, to rubber sealer.

**CAUTION:** *Do not use graphite, brake fluid, or wax on rubber sealer.*

#### Replacement

Replacement rubber sealers are coated with powder to prevent stickiness in storage. Remove all powder with a cloth dampened with 3M General Purpose Adhesive Cleaner, or equivalent, before installation.

(1) Carefully remove rubber sealer from liftgate, using needlenose pliers to remove plastic retainers from liftgate panel holes.

(2) Remove dust, dirt and old sealer from rubber sealer, liftgate and enclosure.

(3) Install lower corner of sealer to liftgate first.

(4) Press retainers, starting at lower edge of liftgate, into liftgate panel holes.

(5) Apply a bead of 3M Auto Joint and Seam Sealer, or equivalent, around perimeter of liftgate between rubber sealer and liftgate flange to prevent water from passing seal and entering vehicle.

### WINDOW SYSTEM

#### Replacement

(1) Unlock rubber weatherstrip (fig. 3H-1) using wood wand or fiber stick.

(2) Use fiber stick to break seal between glass and rubber weatherstrip.

(3) Push glass and weatherstrip toward outside of vehicle and remove glass.

(4) Remove weatherstrip from liftgate opening.

(5) Inspect weatherstrip and clean sealer from glass cavity and flange cavity.

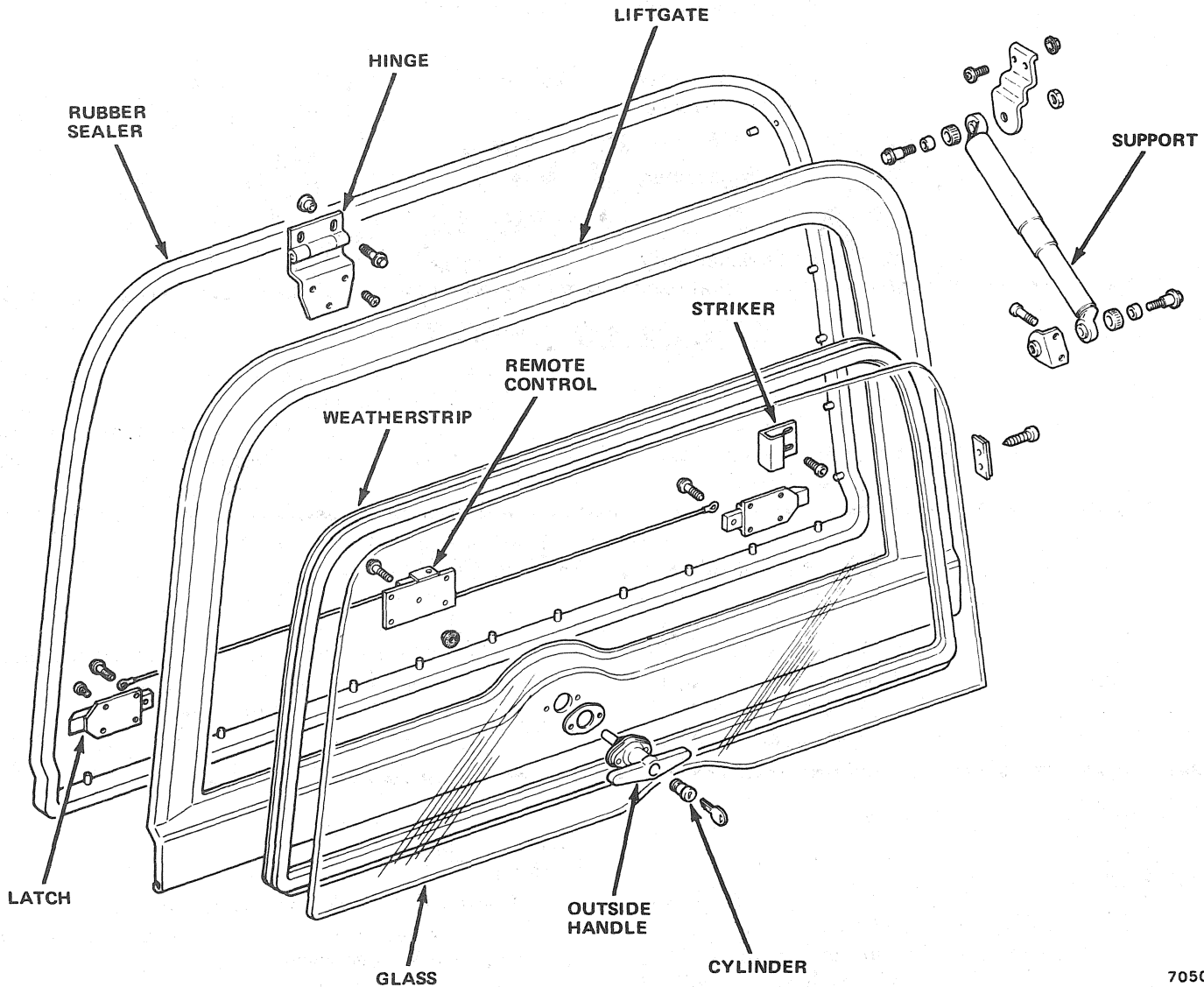

70509

Fig. 3H-1 Liftgate Components

**NOTE:** *Inspect for uneven surfaces or irregularities in the opening flange that could cause stress damage to the glass.*

(6) Before installing weatherstrip on glass, apply 3/16-inch bead of 3M Auto Bedding and Glazing Compound, or equivalent, in weatherstrip flange cavity using pressure-type applicator.

(7) With glass installed in weatherstrip and before installing glass and weatherstrip into opening, insert 1/4-inch cord completely around weatherstrip in flange cavity.

**NOTE:** *The ends of the cord should hang out over the outside surface of the glass approximately in the center of the upper weatherstrip.*

(8) Place glass and weatherstrip into position in window opening with ends of cord hanging outside vehicle.

(9) Pull on ends of cord to pull lip of weatherstrip over body panel. With cord removed, weatherstrip should be positioned correctly.

(10) Use wooden wand to lock weatherstrip.

(11) Using pressure-type applicator, apply 3M Windshield Sealer, or equivalent, between weatherstrip and glass on outside of glass around entire perimeter.

(12) Clean excess sealer from glass and exterior body surface.

(13) Test window for water leaks.

## LOCK SYSTEM

### Outside Handle Replacement

(1) Remove screws attaching remote control to liftgate using Torx Bit Tool J-25359-C.

(2) Remove nuts attaching outside handle to liftgate and remove handle.

**NOTE:** *The replacement outside handle is furnished without the lock cylinder. The lock cylinder is furnished uncoded without keys.*

(3) Code existing door lock key to replacement cylinder.

- (a) Insert key in replacement cylinder.
- (b) File tumblers until flush with cylinder body.
- (c) Remove and install key, and check that tumblers are flush with body.
- (d) Install cylinder in replacement outside handle.

(4) Position outside handle in liftgate and install attaching nuts.

(5) Position remote control on liftgate and install attaching screws using Torx Bit Tool J-25359-C.

### Remote Control Replacement

(1) Loosen screws attaching remote control cables to latch. Disconnect cables from screws.

(2) Remove screws attaching remote control (fig. 3H-1) to liftgate using Torx Bit Tool J-25359-C.

(3) Position remote control on liftgate and install attaching screws using Torx Bit Tool J-25359-C.

(4) Connect remote control cables to latch screws and tighten screws.

### Latch Replacement

(1) Loosen screws attaching remote control cable to latch. Disconnect cable from screw.

(2) Remove screws attaching latch (fig. 3H-1) to liftgate using Torx Bit Tool J-25359-C. Remove latch.

(3) Position latch on liftgate and install attaching screws using Torx Bit Tool J-25359-C.

(4) Connect remote control cable to latch screw and tighten screw.

### Striker Adjustment

The strikers provide durable retention points for the latches and prevent movement of the liftgate. Strikers may be moved in or out to compensate for body and enclosure variations. Use Torx Bit Tool J-25359-C for removal and adjustment.

## SUPPORT SYSTEM

### Replacement

- (1) Open liftgate, support to prevent closing.
- (2) Remove screws attaching supports and remove supports.
- (3) Install supports and attaching screws.

## HINGE SYSTEM

### Replacement

(1) Open liftgate, support to prevent closing.

(2) Remove screws attaching supports to liftgate and fold supports downward.

**WARNING:** *Never remove supports with liftgate closed. The supports are under spring tension and may cause damage or personal injury if removed with liftgate closed. After removal, do not attempt to dismantle or repair the supports.*

(3) Using Torx Bit Tool J-25359-C, remove screws attaching hinge to liftgate.

(4) Using Torx Bit Tool J-25359-C, remove screws attaching hinge to enclosure. Remove hinge from enclosure.

(5) Clean replacement hinge in suitable solvent and blow dry with compressed air.

(6) Color-coat hinge to match enclosure.

(7) Lubricate hinge with 3M 4-Way Spray lubricant, or equivalent.

(8) Position hinge on enclosure and install attaching screws, using Torx Bit Tool J-25359-C.

(9) Position liftgate on hinge and install hinge-to-liftgate attaching screws using Torx Bit Tool J-25359-C.

(10) Position supports on liftgate and install attaching screws.

## LIFTGATE REMOVAL

(1) Open liftgate, support to prevent closing.

(2) Remove screws attaching supports to liftgate and fold supports downward.

**WARNING:** *Never remove supports with liftgate closed. The supports are under spring tension and may cause damage or personal injury if removed with liftgate closed. After removal, do not attempt to dismantle or repair the supports.*

(3) Using Torx Bit Tool J-25359-C, remove screws attaching hinges to liftgate and remove liftgate.

## LIFTGATE INSTALLATION

(1) Position liftgate on hinges and install hinge-to-liftgate attaching screws using Torx Bit Tool J-25359-C.

(2) Position supports on liftgate and install attaching screws.

(3) Check liftgate alignment. Adjust if necessary. (Refer to Liftgate Adjustment.)

## LIFTGATE ADJUSTMENT

(1) Open liftgate, support to prevent closing.

(2) Remove screws attaching supports to liftgate and fold supports downward (fig. 3H-1).

**WARNING:** *Never remove supports with liftgate closed. The supports are under spring tension and may cause damage or personal injury if removed with liftgate closed. After removal, do not attempt to dismantle or repair the supports.*

(3) Using Torx Bit Tool J-25359-C, remove screws attaching latches to liftgate.

**NOTE:** *Do not disconnect remote control cables from latches.*

---

(4) Loosen screws, using Torx Bit Tool J-25359-C, attaching hinges.

(5) Close liftgate and shift liftgate to obtain desired gap (side-to-side).

(6) Open liftgate and tighten hinge-to-liftgate screws using Torx Bit Tool J-25359-C.

(7) Position latches on liftgate and install attaching screws using Torx Bit Tool J-25359-C.

(8) Position supports on liftgate and install attaching screws.

---

## CJ-5 TAILGATE

---

### GENERAL

The hinged tailgate is held in the closed, up position with hooks which pass through slotted brackets on the tailgate and on the body. The hinges are designed in such a way that the tailgate can be removed easily. The body half of the hinge is slotted and the tailgate half has a matching flat surface. However, to prevent accidental dropping of the tailgate, the flat surface on the left hinge pin is not in line with the flat surface on the right hinge pin.

(2) Rotate tailgate an additional few degrees and then disengage left hinge.

### INSTALLATION

(1) Hold tailgate at approximately 45 degrees from full up position and engage right hinge.

(2) Rotate tailgate an additional few degrees and then engage left hinge.

### ADJUSTMENT

(1) Loosen hinge attaching bolts and slide body half of hinge up, down, or to side as needed.

(2) Tighten bolts.

---

## CJ-7 TAILGATE

---

### GENERAL

The new tailgate is hinged at the bottom and held in the closed up position with dual latches. The tailgate is supported in the open position by two steel cables.

(2) Install hinge attaching screws using Torx Bit Tool J-25359-C.

(3) Position support cables on tailgate and install attaching screws and wave washers.

### REMOVAL

(1) Remove screws and wave washers attaching support cables to tailgate.

(2) With tailgate closed, remove screws attaching hinges to tailgate using Torx Bit Tool J-25359-C. Disengage latches and remove tailgate.

### ADJUSTMENT

(1) Loosen hinge-to-body attaching screws and align tailgate to body opening.

(2) Tighten hinge attaching screws.

### INSTALLATION

(1) Position and align tailgate in body opening and engage latches.

### HINGE REPLACEMENT

(1) Remove all hinge attaching screws using Torx Bit Tool J-25359-C and remove hinge.

(2) Clean replacement hinge in suitable solvent and blow dry with compressed air.

(3) Paint hinge to match body with Jeep exterior spray paint.

(4) Lubricate hinge with 3M 4-Way Spray lubricant or equivalent.

(5) Position hinge on body and tailgate and install attaching screws using Torx Bit Tool J-25359-C.

## RUBBER SEALER

The tailgate rubber sealer is made of molded latex foam with a smooth rubber skin on the outside.

Plastic retainers are used to retain the rubber sealer to the tailgate. Barbs on the retainers depress when inserted in the holes and spread when fully inserted.

## Maintenance of Rubber Sealers

Cold weather may cause the rubber sealer to harden and lose resiliency. This may cause the tailgate to loosen in the opening, resulting in vibration and noise. When servicing, use a dampened cloth to clean rubber sealer.

Clean dirt from all points where the rubber sealer contacts the body. Apply AMC Silicone Lubricant, or equivalent, to rubber sealer.

**CAUTION:** Do not use graphite, brake fluid, or wax on rubber sealer.

## Replacement

Replacement rubber sealers are coated with powder to prevent stickiness in storage. Remove all powder with a cloth dampened with 3M General Purpose Adhesive Cleaner, or equivalent, before installation.

(1) Carefully remove rubber sealer from tailgate using needlenose pliers to remove plastic retainers from tailgate panel holes.

(2) Remove dust and dirt from rubber sealer, tailgate, and body.

(3) Install lower corner of rubber sealer to tailgate first.

(4) Press plastic retainers into tailgate panel holes.

# CHEROKEE - WAGONEER TAILGATES

	Page		Page
Adjustment	3H-5	Power Tailgate Window System	3H-9
General	3H-5	Tailgate Installation	3H-7
Hinge Replacement	3H-7	Tailgate Removal	3H-7
Lock System	3H-7	Window System	3H-8

## GENERAL

The tailgate is a horizontally hinged unit equipped with a manual or electrically operated window regulator. An access hole in the inner panel is for installing and servicing the window regulator and latch assemblies (fig. 3H-2).

The torque rods serve to counterbalance and assist in opening as well as closing the tailgate.

Tailgate hinges are accessible at the body side of the hinge for easier adjustment or replacement.

Tailgate weatherseal is body-mounted for better wind and water-leak resistance.

## ADJUSTMENT

Tailgate adjustment is similar to side door adjustments; proper alignment is obtained by changing the position of the hinges relative to the body and tailgate. On models equipped with carpeting, remove carpeting to gain access to hinge cover plates. Cherokee and Wagoneer vehicles have hinge cover plates in the body floor and tailgate for easy access to hinge screws (fig. 3H-2). The dovetail assemblies, which stabilize the tailgate and

function as an overslam bumper, are adjusted by bringing the dovetail studs into alignment with the dovetail cap. The dovetail studs are located on the body pillars near the striker plates, and are adjustable. The dovetail caps are located on the tailgate and are nonadjustable.

## Hinges

(1) Remove dovetail studs from body pillars.

(2) If equipped with carpeting, remove carpeting to gain access to hinge cover plates.

(3) Remove two body hinge cover plates.

(4) Loosen screws attaching hinges to body and adjust floating plates until lower portion of tailgate closes flush or underflush with body sheet metal to ensure proper compression of weatherseal. Tighten hinge screws to 15 to 20 foot-pounds (20 to 27 N•m) torque.

(5) Install body hinge cover plates and carpeting, if equipped.

(6) Install and adjust dovetail studs.

## Dovetail Assemblies

(1) Loosen dovetail stud locking nuts.

(2) Close tailgate into locks.

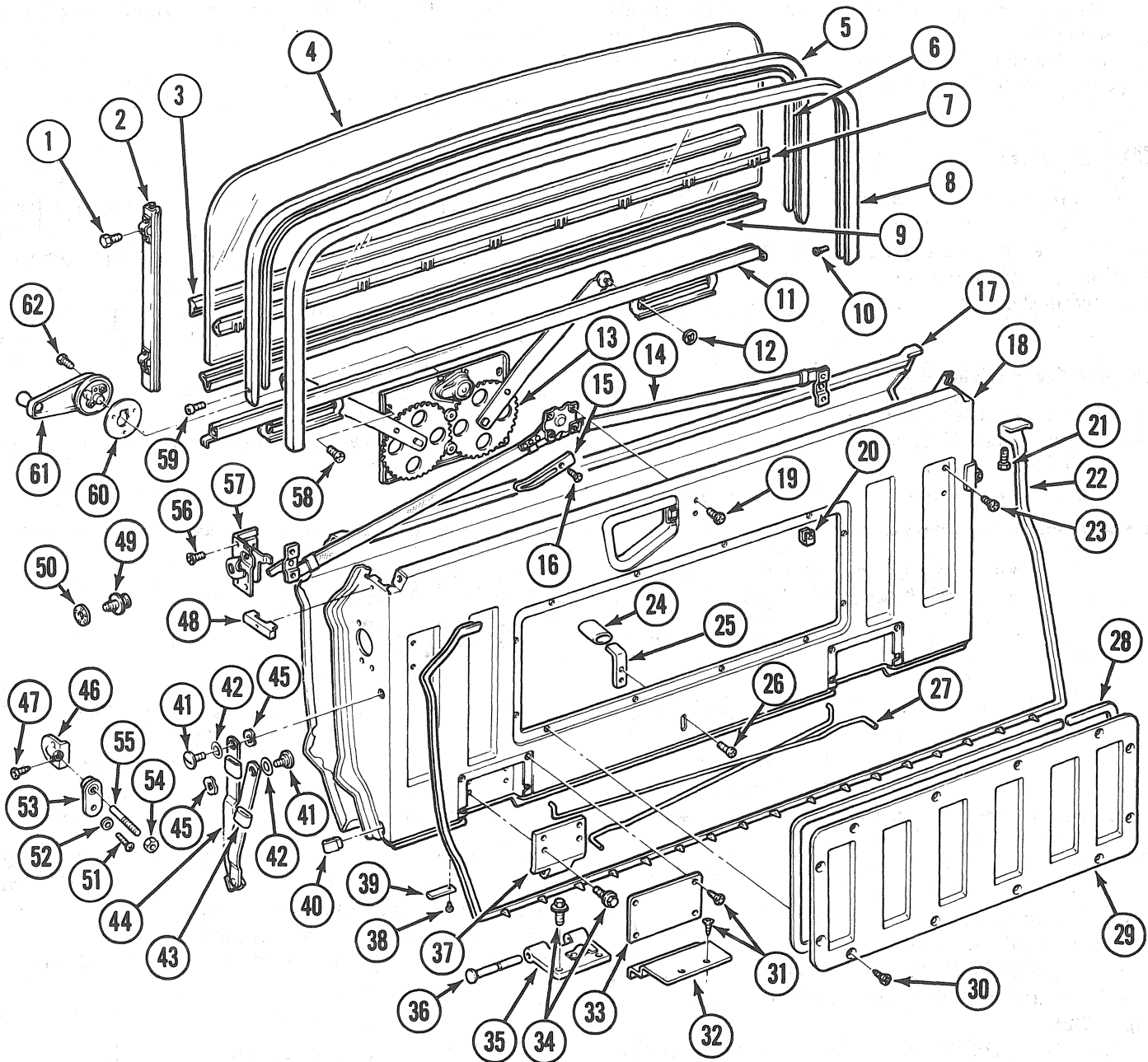

- 1. HEXAGON SCREW
- 2. LOWER CHANNEL
- 3. WEATHERSTRIP
- 4. TAILGATE GLASS
- 5. RUN CHANNEL
- 6. UPPER CUSHION
- 7. WEATHERSTRIP
- 8. GLASS FRAME
- 9. CHANNEL SEALER
- 10. TAPPING SCREW
- 11. BOTTOM CHANNEL
- 12. STUD RETAINER
- 13. WINDOW REGULATOR
- 14. REMOTE CONTROL
- 15. RELEASE HANDLE
- 16. OVAL HEAD SCREW

- 17. OUTER PANEL
- 18. TAILGATE
- 19. MACHINE SCREW
- 20. SPEED NUT
- 21. PLASTIC RIVET
- 22. TAILGATE SEALER
- 23. MACHINE SCREW
- 24. BRACKET BUMPER
- 25. STOP BRACKET
- 26. MACHINE SCREW
- 27. TORQUE ROD
- 28. COVER GASKET
- 29. ACCESS COVER
- 30. TAPPING SCREW
- 31. TAPPING SCREW
- 32. COVER PLATE

- 33. COVER PLATE
- 34. HINGE SCREW
- 35. BODY HALF HINGE
- 36. HINGE PIN
- 37. TAILGATE HALF HINGE
- 38. PLASTIC RIVET
- 39. DUST SEAL
- 40. ARM BUMPER
- 41. SHOULDER BOLT
- 42. SPRING WASHER
- 43. ARM SLEEVE
- 44. SUPPORT ARM
- 45. LOCKWASHER
- 46. DOVETAIL CAP
- 47. TAPPING SCREW
- 48. END CAP

- 49. TAILGATE STRIKER
- 50. STRIKER WASHER
- 51. MACHINE SCREW
- 52. LOCKWASHER
- 53. TAILGATE DOVETAIL
- 54. HEXAGON NUT
- 55. DOVETAIL STUD
- 56. MACHINE SCREW
- 57. TAILGATE LATCH
- 58. MACHINE SCREW
- 59. MACHINE SCREW
- 60. HANDLE GASKET
- 61. REGULATOR HANDLE
- 62. MACHINE SCREW

Fig. 3H-2 Tailgate with Manual Regulator—Cherokee-Wagoneer Models



(3) Adjust dovetail studs, using Torx Bit Tool J-25359-C, into dovetail caps and tighten stud locking nuts.

(4) Check tailgate for proper alignment and adjustment. Be sure tailgate latches properly with strikers and dovetails align into caps.

### Striker Assemblies

(1) Loosen dovetail stud locking nuts.

(2) Latch forks should be aligned and nest in the center of the strikers.

(3) Add or remove striker shims to obtain this adjustment.

(4) Adjust strikers using Torx Bit Tool J-25359-C so latches engage strikers freely and tailgate fits flush with adjacent panels.

(5) Adjust dovetail studs.

### HINGE REPLACEMENT

(1) Open tailgate. If vehicle is equipped with cargo area floor covering, remove mouldings and place floor covering aside.

(2) Remove access hole cover plates from body and tailgate.

(3) Raise tailgate to vertical position to unload counterbalance torque rods, and pry rods from clip welded to body half of hinge.

(4) Using wax pencil, mark outline of existing hinge(s) on body and tailgate for reference.

(5) Support tailgate in horizontal position, remove screws attaching hinge(s), and remove hinge(s).

(6) Clean replacement hinge(s) in suitable solvent and blow dry with compressed air.

**CAUTION:** *Do not immerse hinge in solvent.*

(7) Color coat hinges to match body.

(8) Lubricate hinges with 3M 4-Way Spray lubricant, or equivalent.

(9) Install replacement hinge(s), being careful to align with wax pencil marks. Tighten screws to 15 to 20 foot-pounds (20 to 27 N•m) torque.

(10) Raise tailgate to vertical position and install counterbalance torque rods in welded clips on body half of hinges.

(11) Check tailgate alignment and adjust if necessary.

(12) Install access hole cover plates on body and tailgate and, if equipped, replace cargo area floor covering and mouldings.

### TAILGATE

#### Removal

(1) Remove carpeting from tailgate, if equipped.

(2) Remove tailgate access cover and disconnect wiring.

(3) Remove carpeting, if equipped, to gain access to hinge access hole cover plates.

(4) Remove hinge access hole cover plates on body.

(5) Close tailgate and drive out hinge pins.

(6) With tailgate in vertical position, counterbalance torque rods are unloaded and can be removed from clip which is attached to body half of hinge.

(7) Remove screws holding lower end of support arms to tailgate.

### Installation

(1) Attach support arms to tailgate and raise tailgate to vertical position in tailgate opening.

(2) Insert curved end of one torque rod in hole at bottom edge of tailgate and right-angle tapered end of rod in clip which is attached to body half of hinge. Attach other torque rod in same manner.

(3) Install hinge pins with head of pin on inboard side of hinge.

(4) Install hinge access hole cover plates on body.

(5) Install carpeting, if equipped.

(6) Connect wiring and replace tailgate access cover and carpeting, if equipped.

(7) Adjust tailgate.

### LOCK SYSTEM

#### Remote Control Replacement

(1) Lower tailgate and move tailgate glass to extreme out position so remote control assembly will be accessible. Tailgate glass should be supported to relieve stress on its lower edge.

(2) Remove carpeting from tailgate, if equipped.

(3) Remove access cover and tailgate release handle from remote control.

(4) Remove screws attaching center of remote control assembly.

(5) Remove screws from each end of remote control rods.

(6) Release lower edge of vinyl water shield on vehicle, if equipped.

(7) Pull rods down toward bottom of tailgate to obtain side clearance.

(8) Move remote control assembly toward side of tailgate and free remote control from latch opening in tailgate. Remove remote control assembly through access cover opening.

(9) Position remote control assembly in tailgate.

(10) Install screws attaching end of each remote control rod.

(11) Install screws attaching center of remote control assembly.

(12) Install tailgate access cover and carpeting, if equipped.

### Latch Replacement

(1) Lower tailgate and move tailgate glass to extreme out position so remote control assembly will be accessible. Tailgate glass should be supported to relieve stress on its lower edge.

(2) Remove carpeting from tailgate, if equipped.

(3) Remove access cover and remove screws attaching ends of remote control rods to tailgate.

(4) Remove screws attaching latch assemblies to ends of gate and remove latch assembly.

(5) Clean replacement latch in suitable solvent and blow dry with compressed air.

**CAUTION:** Do not immerse latch in solvent.

(6) Color coat latch to match body.

(7) Position latch assembly in tailgate and install attaching screws.

(8) Install access cover and carpeting, if equipped.

(9) Adjust striker, if necessary.

### WINDOW SYSTEM

#### Glass Replacement

Tailgate glass is operated by a double-arm window regulator which is connected directly to an outside window regulator handle. The complete window assembly will slide up and out of the run channels when the pins at the ends of the regulator arms are withdrawn from the slot in the lifter channel.

(1) Remove carpeting from tailgate, if equipped, and remove access cover on inside tailgate panel.

(2) Remove studs retainers from window regulator arm studs.

(3) Disconnect window regulator arm studs from bottom channel.

(4) Disconnect tailgate window defogger, if equipped.

(5) Remove tailgate glass assembly and discard.

(6) Check tailgate glass operating mechanism for bent or damaged components. Replace as necessary.

(7) Clean lower section of replacement tailgate glass with isopropyl alcohol or equivalent.

**NOTE:** Do not wipe or rub grid area when cleaning glass.

(8) Obtain replacement tailgate glass bottom sealer 8130418 and cut two pieces 53-1/2 inches long.

(9) Position one sealer on top of other with adhesive sides together forming a 0.090-inch thick strip 53-1/2 inches long. Firmly press together.

(10) Position glass with bottom edge facing up and top edge on cushion to prevent damage to glass.

(11) Remove release paper from one side of sealer. Starting at one end, center sealer over edge of glass. Lay sealer along complete bottom length of glass, keeping sealer centered over edge of glass.

**NOTE:** Do not wrap sealer around the bottom edge of the glass at this time.

(12) Remove second release paper from sealer and wrap sealer around bottom edge of glass.

(13) Install replacement bottom channel on glass by pressing or tapping channel into position.

**NOTE:** Ensure channel is fully seated on glass.

(14) Install glass and channel assembly in tailgate.

(15) Connect tailgate window defogger, if equipped.

(16) Connect window regulator arm studs to bottom channel.

**NOTE:** Retainers can be damaged when removed and their condition should be checked. When installing retainers, the tabs must be firmly locked in groove of stud. If difficulty is experienced when installing the retainers, they were probably damaged during removal and should be replaced.

(17) Install stud retainers on window regulator arm studs.

(18) Install access cover.

(19) Install carpeting, if equipped.

#### Regulator Replacement

(1) Remove carpeting from tailgate, if equipped, and remove access cover.

(2) Remove tailgate glass.

(3) Remove regulator by sliding dust cover aside and rotating handle until hole in handle is aligned with screws that attach handle assembly to tailgate. Remove attaching screws and handle.

(4) Remove screws that attach regulator assembly to tailgate.

(5) Remove regulator assembly through access cover opening.

(6) After installation and before access cover is replaced, raise and lower window to check that window fits properly. The window regulator can be adjusted by loosening attaching screws and moving regulator assembly in slotted screw holes until proper window adjustment is obtained.

(7) Adjust handle to be in vertical position when window is full up.

#### Glass Adjustment

The tailgate glass, when closed, must seat fully into the upper glass channel to obtain a positive seal at horizontal weatherstrip located at the top of the tailgate. If tailgate does not seat properly when closed, check the upper glass channel to be certain it is bottomed in the body opening, also check alignment of the tailgate glass run channel.

(1) If adjustment is necessary, loosen two cap-screws on either side panel of tailgate (fig. 3H-3).



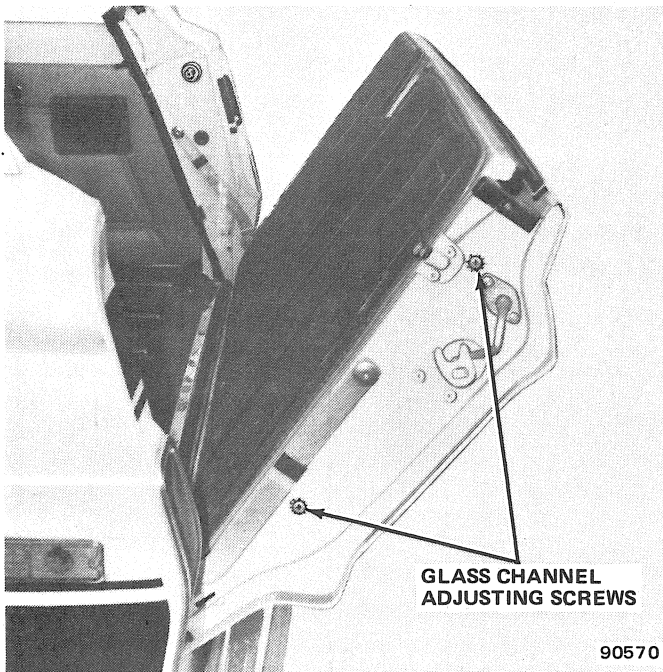

Fig. 3H-3 Glass Channel Adjustment

(2) Raise and lower glass several times with tailgate in closed position. This will align glass with channel.

(3) Open tailgate slightly and tighten adjusting screws with tailgate in vertical position.

## POWER TAILGATE WINDOW SYSTEM

### General

An electrically operated tailgate window is offered on Cherokee and Wagoneer models. When checking for tailgate window motor operation, be sure instrument panel switch black lead is properly grounded. The tailgate motor grounds through this switch. It is necessary to isolate the problem to one of the two operating circuits: (1) tailgate window operation from instrument panel switch and (2) tailgate window operation from tailgate window switch.

### Operation

#### Instrument Panel Switch

Current is supplied from battery to ignition switch to fuse panel, through a 30-amp circuit breaker (located in the fuse panel), and to instrument panel tailgate window switch (fig. 3H-4).

**NOTE:** If the vehicle is equipped with a tailgate window defogger, the defogger and tailgate switches are serviced as an assembly. They cannot be replaced separately. Both switches must be replaced when either is defective.

#### Tailgate Window Switch

Current is supplied directly to fuse panel, through a 30-amp circuit breaker, and to red w/tr (No. 46) wire of tailgate window switch (fig. 3H-4).

#### Testing

##### Instrument Panel Tailgate Window Switch

**NOTE:** Be sure instrument panel tailgate window switch black lead is properly grounded. The tailgate motor grounds through this switch.

- (1) Turn ignition switch to on position.
- (2) Using 12-vdc test lamp, connect one end of test lamp to ground and place probe to red (No. 53) wire of switch. If lamp lights, voltage is present at switch. If lamp does not light, repair problem in feed circuit before proceeding.
- (3) Place test lamp probe to brown (No. 47) wire of switch. Move switch to up position. If lamp lights, proceed to step (4). If lamp does not light, replace switch.
- (4) Place test lamp probe to tan (No. 48) wire of switch. Move switch to down position. If lamp lights, proceed to Tailgate Window Switch Test. If lamp does not light, replace switch.

##### Tailgate Window Switch

**NOTE:** Be sure instrument panel tailgate window switch black lead is properly grounded. The tailgate motor grounds through this switch.

- (1) Using 12-vdc test lamp, connect one end of test lamp to ground and place probe to red w/tr (No. 46) wire of tailgate window switch. If lamp lights, proceed to step (2). If lamp does not light, repair problem in feed circuit before proceeding.
- (2) Place test lamp probe to tan (No. 48A) wire of tailgate switch. Turn tailgate window switch key to down position. If lamp lights, proceed to step (3). If lamp does not light, replace switch.
- (3) Place test lamp probe to brown (No. 47B) wire of tailgate switch. Turn tailgate window switch key to up position. If lamp lights, proceed to next test. If lamp does not light, replace switch.

##### Tailgate Window Safety Switch

- (1) Using 12-vdc test lamp, connect one end of test lamp to ground and place probe to brown wire of safety switch. Turn tailgate window switch to up position. If lamp lights, voltage is present at switch. If lamp does not light, repair feed circuits as necessary.
- (2) Place test lamp probe to brown wire at switch. Turn tailgate window switch to up position and close safety switch. If lamp lights, proceed to next test. If lamp does not light, replace switch.

# 3H-10 LIFTGATES—TAILGATES

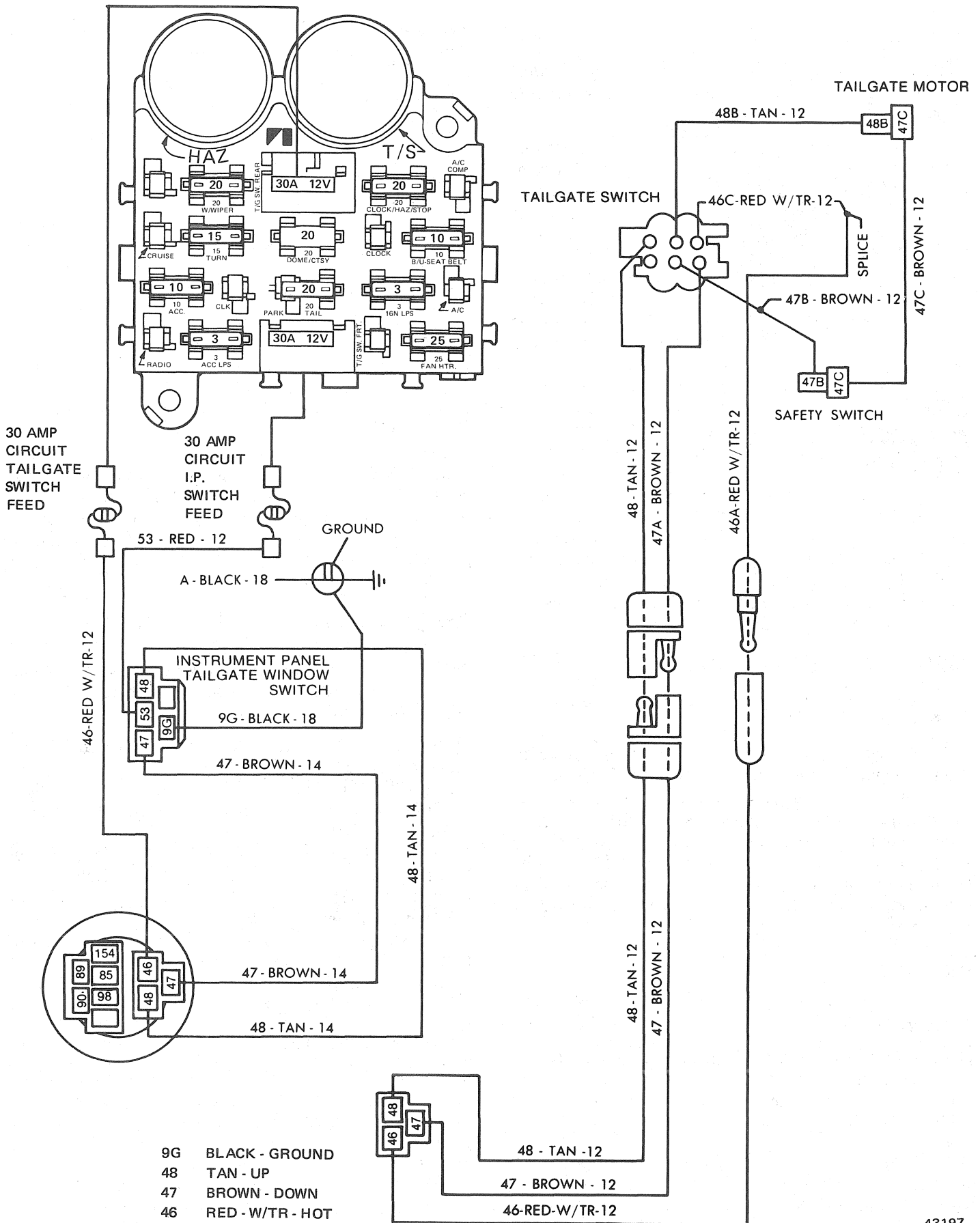

Fig. 3H-4 Power Tailgate Window Circuitry—Cherokee-Wagoneer Models

## Tailgate Window Motor

**NOTE:** *Be sure instrument panel tailgate window switch black lead is properly grounded. The tailgate motor grounds through this switch.*

(1) Using 12-vdc test lamp, connect one end of test lamp to ground and place probe to tan (No. 48B) wire at electrical motor. Close safety switch. Turn tailgate window switch to down position. If lamp lights and motor does not operate, replace motor. If lamp does not light, check feed circuit to motor and repair as necessary.

(2) Place test lamp probe to brown (No. 47C) wire at electric motor. Close safety switch. Turn tailgate window switch to up position. If lamp lights and motor does not operate, replace motor. If lamp does not light, check feed to motor and repair as necessary.

The ignition switch must be in either the accessory or ignition position to energize the window lift circuit.

The rear window control switch is located to the left of the steering column on the instrument panel. The switch is spring-loaded and will return to the neutral position.

The tailgate glass also can be lowered or raised, by inserting the ignition key in the tailgate lock. Turn the key to the left to lower and to the right to raise the tailgate glass.

After the glass has been lowered, the tailgate can be opened by lifting up on the tailgate latch release handle on the inside of the tailgate at the center.

**NOTE:** *The tailgate safety switch is in series with the brown wire which feeds the up or down circuit of the tailgate motor. It prevents operation when the tailgate is open.*

The proper assembly of all movable parts is important for satisfactory operation of the tailgate window.

The glass assembly must be in alignment in the tailgate and glass slide channels to operate with free movement. The window regulator teeth in all gears, the coil springs, and the bottom channel slide sections must be lubricated with 3M 4-Way Spray lubricant, or equivalent, to ensure proper operation of the glass when it is raised or lowered.

## Safety Switch

A safety switch, mounted in the upper left side of the tailgate, prevents operating the glass when the tailgate is in the open position to avoid possible damage to glass channels and regulator.

## Circuit Breakers

The electric tailgate regulator motor and wiring harness are protected by two 30-ampere circuit breakers located in the fuse panel.

## Instrument Panel Switch

The rear window switch is mounted at the lower left side of the instrument panel. For removal, remove knob

by depressing spring clip. Remove attaching screws. Disconnect wiring and remove switch.

## Wiring Harness

The tailgate circuit is a two-section wire harness: the body section, which is routed along the left side of the vehicle, and the section in the tailgate. The two harnesses are connected at the rear body crossmember.

Remove the tailgate access cover to gain access to the wiring harness.

## Key Lock

The tailgate key lock assembly is held in place by two special screws located under the key hole cover. Remove the screws using Torx Bit Tool J-25359-C.

## Window Switch

The tailgate window switch is mounted to the bottom side of the left regulator mounting support. It is fastened with two screws which are visible and accessible after the window regulator is removed.

## Regulator

### Removal

- (1) Remove carpet from tailgate, if equipped.
- (2) Remove tailgate access cover plate.
- (3) Remove retainers attaching regulator arms to channel.
- (4) Disengage regulator arm pins from channel and raise glass.
- (5) Carefully support glass in the raised position.
- (6) Disconnect wiring harness from motor.
- (7) If regulator attaching screws are accessible, remove regulator attaching screws and regulator. If sector gears are covering attaching screws, proceed as follows:
  - (a) Remove motor attaching screws and disconnect motor drive from gear regulator.
  - (b) Grasp regulator arm as far outboard as access hole will allow.
  - (c) Push down on arm until holes in sector gears align with attaching screws and motor.
  - (d) While holding regulator in this position, wedge screw between meshing teeth, using other hand.
  - (e) Remove regulator attaching screws, regulator and motor.
- (8) Release spring tension by using large screwdriver to snap spring from under tension bracket.

### Installation

- (1) Position spring on regulator and snap over tension bracket using large screwdriver.
- (2) Position motor on regulator and install attaching screws.

- (3) Position regulator in tailgate and install attaching screws.
- (4) Connect wiring harness to motor.
- (5) Position channel over regulator arm pins and install replacement retainers.
- (6) Install access cover plate.
- (7) Install carpet, if equipped.

### Motor

### Removal

- (1) Remove tailgate window regulator, as outlined above.
- (2) Remove motor attaching screws (fig. 3H-5) and motor from regulator.

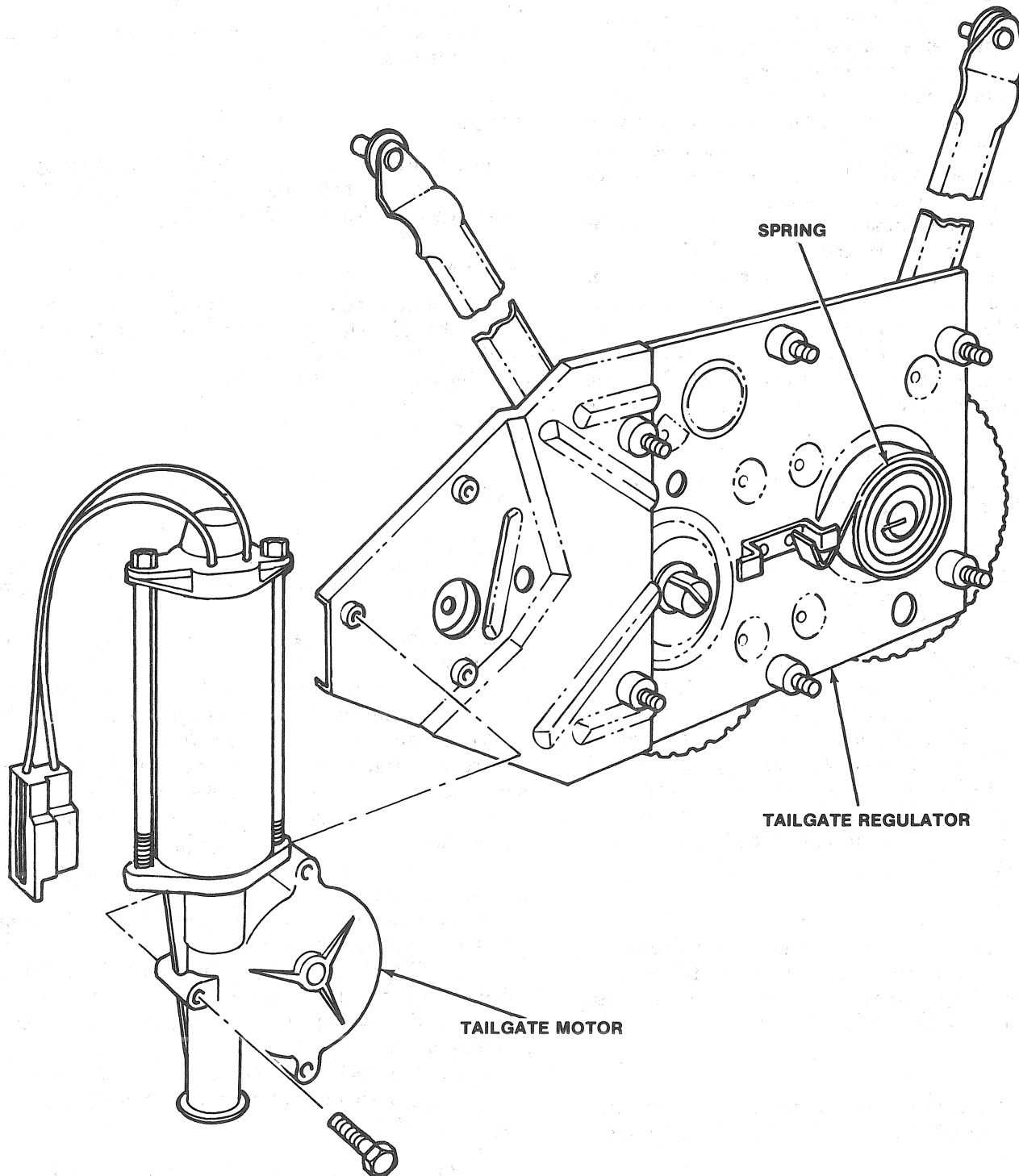

Fig. 3H-5 Power Tailgate Window Regulator and Motor

**Installation**

- (1) Position motor on regulator
- (2) Install motor attaching screws.
- (3) Install tailgate window regulator, as outlined above.
- (4) Check motor operation.

## TOWNSIDE TRUCK TAILGATE

**GENERAL**

The tailgate on the Townside pickup box is hinged at both sides. It is necessary to lower the tailgate for access to the cross-recessed countersunk attaching screws.

The tailgate on the pickup box is held in the up or closed position with spring-loaded latches at the top of the gate. A paddle handle, located in the center of the tailgate operates the latches at each side through connecting rods.

Pin type hinges are located on the sides of the pickup box. The hinge pin brackets are attached with cross-

recessed countersunk attaching screws and cage nuts for easier adjusting.

The left side hinge pin is a solid round bar. The right side pin is similar but with two flat surfaces which correspond with a notch and the two flat surfaces allow the tailgate to be removed quickly from the tailgate opening.

To remove, open and lower the tailgate. Remove the side supports and then raise the tailgate to about 45 degrees from horizontal. Disengage the right side hinge and move the tailgate to the right to disengage the left side hinge.

## SPORT TRUCK TAILGATE

**GENERAL**

The tailgate on the Sport Truck box is hinged at both sides. The hinges can be removed with the tailgate in either the closed or open position.

The tailgate is held in the open or closed position with a chain and hook assembly (fig. 3H-6).

**Removal**

- (1) Disconnect chain assemblies (fig. 3H-6).
- (2) Support tailgate assembly.
- (3) Remove hinge attaching hardware.
- (4) Remove hinge assemblies.
- (5) Remove tailgate assembly.

**Installation**

- (1) Position tailgate and support.
- (2) Position hinge assemblies on tailgate and body.
- (3) Install hinge attaching hardware.

**NOTE:** Do not tighten attaching hardware until both hinges are positioned.

- (4) Align tailgate and tighten attaching hardware.
- (5) Connect chain assemblies.

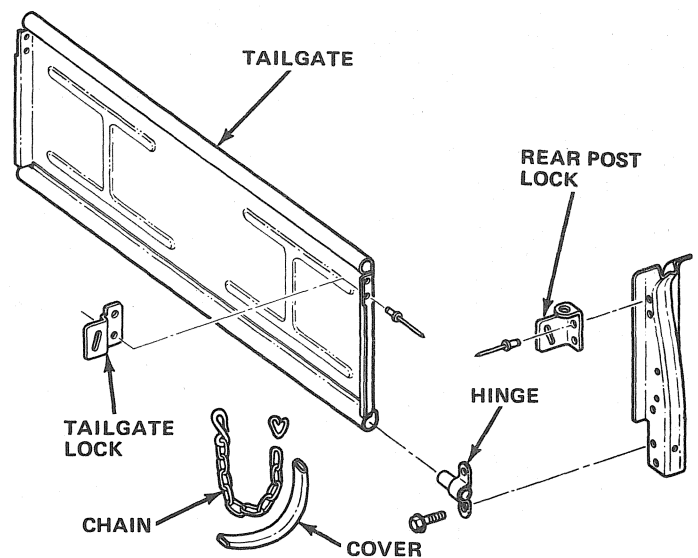

81002B

Fig. 3H-6 Tailgate Assembly—Sport Truck Model

**Tools**

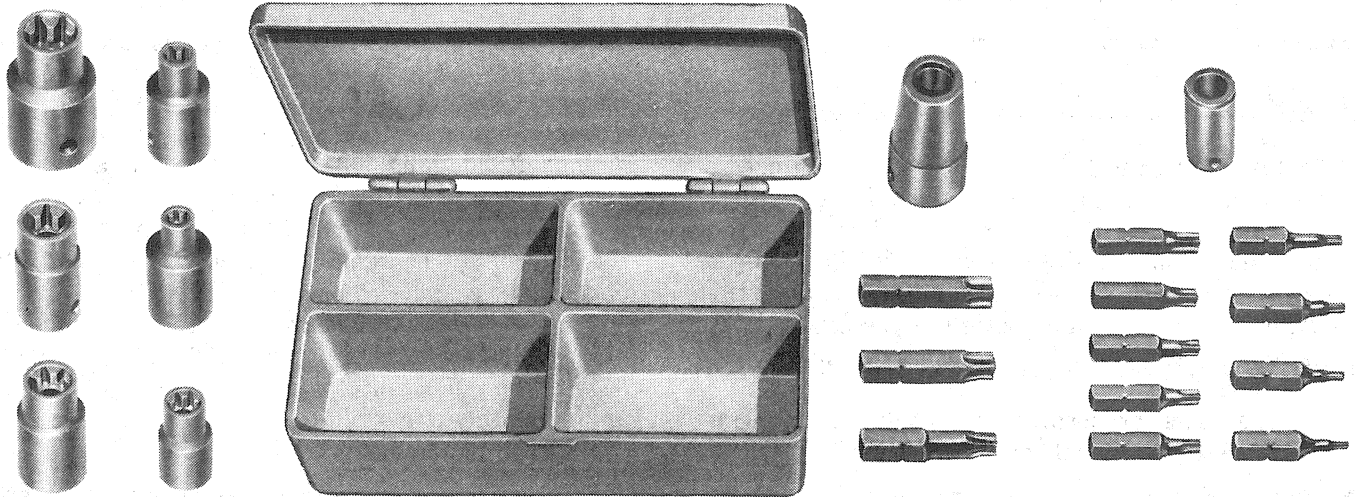

**J-25359-C  
TORX BIT AND SOCKET SET**