

BRAKES 2G

SECTION INDEX

	Page		Page
Brake Hydraulic System	2G-20	General Information	2G-1
Disc Brakes	2G-41	Power Brake Units	2G-31
Drum Brakes	2G-34	Tools	2G-56

GENERAL INFORMATION

	Page		Page
Brake Diagnosis	2G-1	General	2G-1
Brakelamp Switch	2G-17	Parking Brake Adjustment	2G-15
Brakelining Inspection	2G-18	Parking Brake Cables	2G-16
Brake Pedal	2G-14	Service Brake Adjustment	2G-17
Brake Warning Lamp	2G-14	Specifications	2G-19

GENERAL

Jeep vehicles are equipped with single piston, floating caliper front disc brakes and self-energizing rear drum brakes.

Two different disc brake calipers are used. The caliper used on CJ models slides on abutment surfaces machined into the caliper and caliper support bracket. The caliper used on Cherokee, Wagoneer and Truck models slides on pivot bolts installed in the support shield and bracket assembly. Refer to the Brake Size and Application Chart for size and application details.

Two different drum brake units are used. They are similar in construction and operation but differ in method of automatic adjustment. Rear drum brakes on CJ models have cable operated automatic adjusters while rear drum brakes on Cherokee, Wagoneer and Truck models have linkage operated adjusters.

A dual reservoir master cylinder that provides separate hydraulic systems for the front and rear brake units is used on all models.

A three-function combination valve is used on all Jeep models. The valve consists of a one-piece housing containing a front brake metering valve, pressure differential warning valve, and rear brake proportioning valve.

Three power brake units are used. CJ models with optional power assist brakes use an 8 inch (20.3 cm)

single diaphragm power unit. Cherokee, Wagoneer and J-10 Truck models use a 9-1/2 inch (24.1 cm) single diaphragm power unit. J-20 Truck models use a 9-1/2 inch (24.1 cm) tandem diaphragm power unit.

BRAKE DIAGNOSIS

Brake system preliminary diagnosis procedures are outlined in Brake Diagnosis Guides A and B. Guide A applies to all vehicles and Guide B applies to vehicles equipped with power brakes only. Do not use Guide B until all of the steps outlined in Guide A have been completed.

The procedures outlined in the Brake Diagnosis Guides are provided as a method for determining the general problem area. After the general problem area has been defined, refer to the Power Unit, Disc Brake, and Drum Brake Service Diagnosis Charts to determine the specific cause of a brake problem.

In most cases, an owner will describe a brake problem as one or more of the conditions listed in the Service Diagnosis Charts. However, to ensure an accurate diagnosis and avoid ineffective repair, road test the vehicle (if possible), perform the procedures outlined in the Diagnosis Guides, and then consult the Service Diagnosis Charts before attempting problem correction.

Brake Diagnosis Guide A

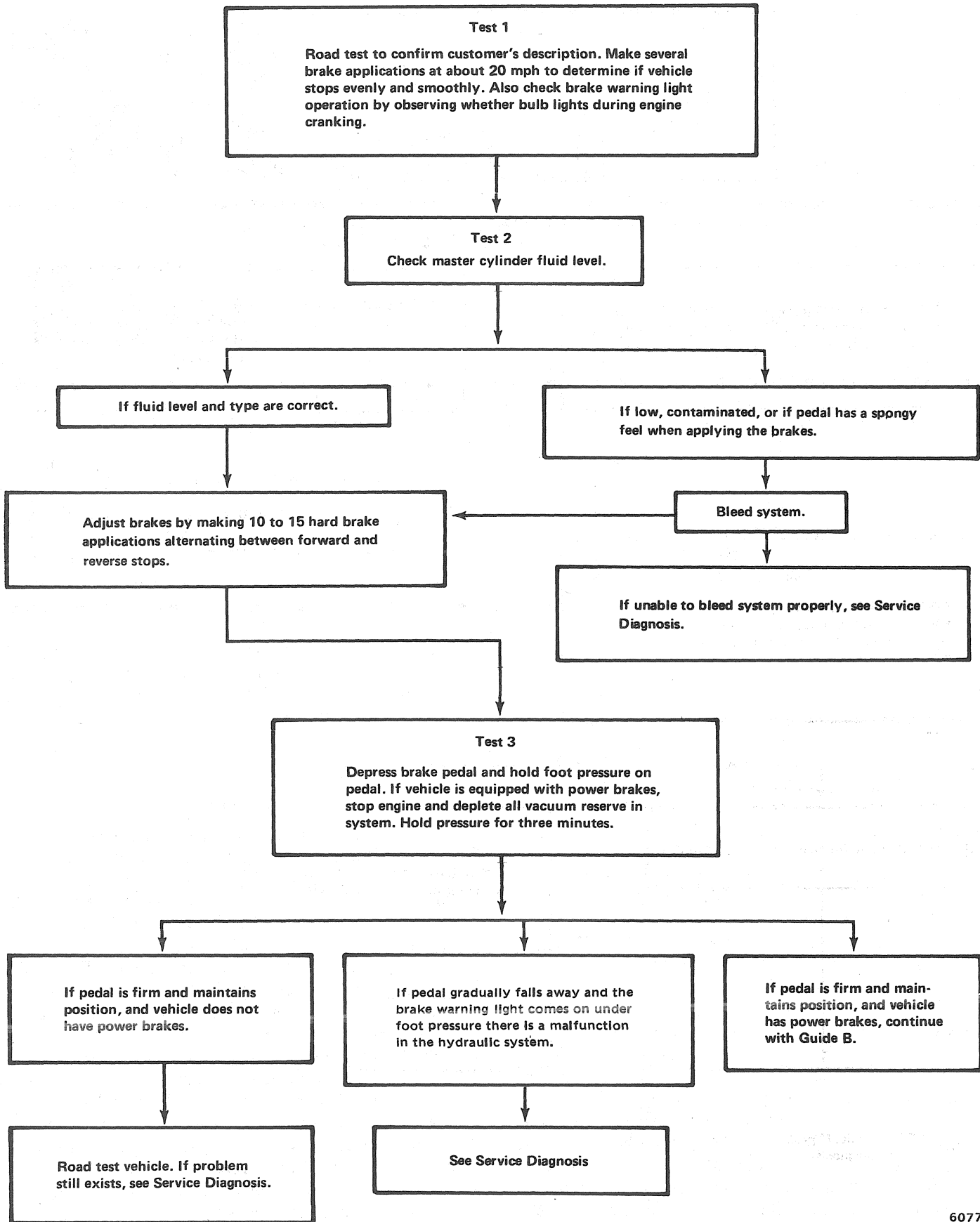

Brake Diagnosis Guide B

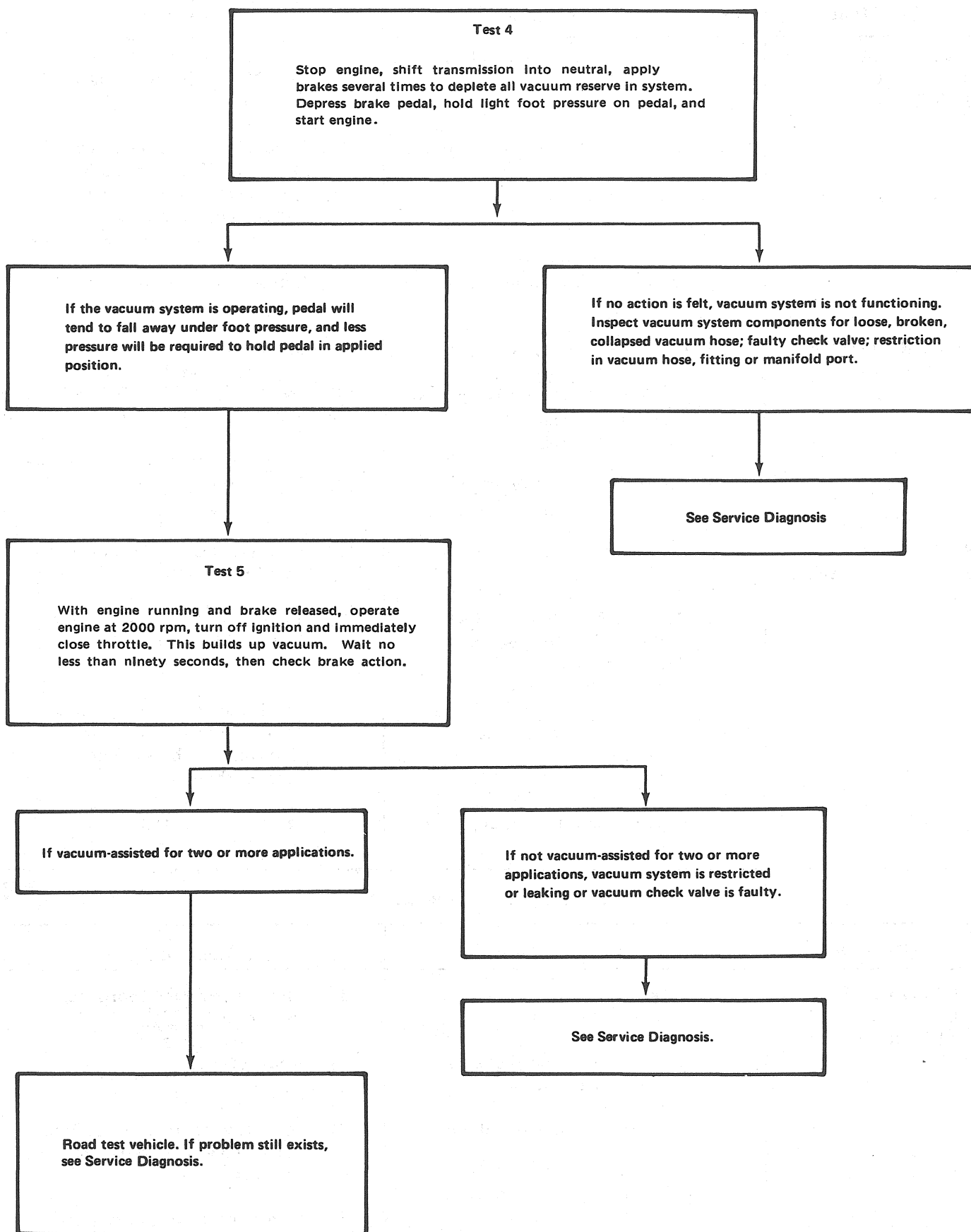

Service Diagnosis-Power Unit

Condition	Possible Cause	Correction
HARD PEDAL (NO POWER ASSIST)	(1) Refer to EXCESSIVE PEDAL EFFORT. (2) Loss of vacuum to power unit. (3) Internal malfunction in power unit.	(1) Refer to EXCESSIVE PEDAL EFFORT in Service Diagnosis Charts. (2) Check for loose hose or check valve seal. Check for collapsed or damaged hose. Inspect vacuum check valve for damage or leak. Replace parts as required. (3) Replace power unit.
SLOW RETURN OF BRAKE PEDAL	(1) Power unit bellcrank pivot pins binding (CJ only) or, pedal binding. See PULLS and GRABBING BRAKES in Brake Service Diagnosis Charts. (2) Internal malfunction in power unit.	(1) Lube all pedal pivot points. Remove, clean, lube and install pivot pins. (2) Replace power unit.
GRABBING OR DRAGGING BRAKES	(1) Bellcrank pivot pins binding (CJ only). (2) Refer to PULLS and GRABBING BRAKES in Service Diagnosis Charts. (3) Push rod (in power unit) binding due to corrosion or burrs on push rod. (4) Internal malfunction in power unit.	(1) Remove, clean, lubricate, and install pivot pins. (2) Refer to PULLS and GRABBING BRAKES in Service Diagnosis Charts. (3) Check and correct as required. Do not lube push rod. Clean push rod with brake fluid and clean cloth only. (4) Replace power unit.

60636

Service Diagnosis-Drum Brakes

Condition	Possible Cause	Correction
LOW PEDAL OR PEDAL GOES TO TOE BOARD	(1) Low fluid level. (2) Excessive clearance between lining and drums. (3) Automatic adjusters not working. (4) Leaking brake lines.	(1) Fill reservoir with approved brake fluid. (2) Adjust brakes. (3) Make forward and reverse stops; if pedal stays low, repair faulty adjusters. (4) Repair or replace faulty parts.

60637A

Service Diagnosis-Drum Brakes (Continued)

Condition	Possible Cause	Correction
LOW PEDAL OR PEDAL GOES TO TOE BOARD (Continued)	(5) Leaking wheel cylinders. (6) Internal leak in master cylinder. (7) Air in system. (8) Improper brake fluid.	(5) Overhaul wheel cylinder. (6) Overhaul master cylinder. (7) Bleed system. (8) Flush system and refill with approved fluid.
SPRINGY, SPONGY PEDAL	(1) Air trapped in hydraulic system. (2) Improper brake fluid. (3) Improper lining thickness or location. (4) Drums worn too thin, (beyond 0.060 (1.52 mm) oversize specification) (5) Master cylinder filler vent clogged (6) Hoses-lines collapsed, kinked, leaking. (7) Master cylinder compensator port blocked.	(1) Remove air by bleeding. (2) Flush and bleed system; use approved brake fluid. (3) Install new lining or replace shoe and lining. (4) Replace drum(s) as required. (5) Clean vent or replace cap; bleed brakes. (6) Replace as required. (7) Disassemble master cylinder. Repair as required.
EXCESSIVE PEDAL PRESSURE REQUIRED TO STOP VEHICLE	(1) Brake adjustment not correct. (2) Incorrect lining. (3) Grease or fluid-soaked lining. (4) Improper fluid. (5) Frozen master or wheel cylinder pistons. (6) Brake pedal binding on shaft. (7) Linings watersoaked. (8) Glazed linings. (9) Bell-mouthed, barrel-shaped, or scored drums.	(1) Adjust brakes. (2) Install new linings. (3) Repair grease seal or wheel cylinder. Install new linings. (4) Flush system; use approved brake fluid. (5) Overhaul master or wheel cylinders. (6) Lubricate pivot points. (7) Drive with brakes lightly applied to dry linings. (8) Replace linings. (9) Replace or resurface drums in left and right hand pairs.

Service Diagnosis-Drum Brakes (Continued)

Condition	Possible Cause	Correction
LIGHT PEDAL PRESSURE-BRAKES TOO SEVERE	<ul style="list-style-type: none"> (1) Brake adjustment not correct. (2) Loose support plates. (3) A small amount of grease or fluid on linings. (4) Pedal linkage binding, or power unit bellcrank pivot pins binding (CJ only). (5) Internal bind in power unit. (6) Incorrect lining. (7) Lining loose on shoe. (8) Bell-mouthed, barrel-shaped, or scored drums. (9) Combination valve faulty. 	<ul style="list-style-type: none"> (1) Adjust brakes. (2) Tighten support plates. (3) Replace the linings. (4) Lube linkage and bellcrank pivot pins. (5) Replace power unit. (6) Install new linings. (7) Replace lining or shoe and lining. (8) Turn drums in pairs or replace. (9) Replace combination valve.
PULSATING BRAKE PEDAL	<ul style="list-style-type: none"> (1) Drums out-of-round. (2) Loose brake drum on hub. (3) Worn or loose wheel bearings. (4) Bent shoes or linings. (5) Bent rear axle shaft. (6) Loose or bent support plate. 	<ul style="list-style-type: none"> (1) Refinish or replace drums. (2) Tighten. (3) Replace or adjust. (4) Replace shoe-lining assembly as required. (5) Replace axle shaft. (6) Tighten or replace support plate.
BRAKE FADE	<ul style="list-style-type: none"> (1) Incorrect lining. (2) Air in lines or improper brake fluid. (3) Master cylinder primary piston worn, or bore scored, corroded. 	<ul style="list-style-type: none"> (1) Replace lining. (2) Bleed system. Drain and flush if fluid is improper type. (3) Disassemble master cylinder. Repair as required.
ALL BRAKES DRAG (ADJUSTMENT IS KNOWN TO BE CORRECT)	<ul style="list-style-type: none"> (1) Power unit bellcrank pivot pins binding (CJ only). (2) Improper fluid. (3) On power brakes (CJ only) push rod height is incorrect. 	<ul style="list-style-type: none"> (1) Lubricate pedal pivot or bellcrank pivot pins. (2) Replace fluid and rubber parts. (3) Adjust push rod height.

Service Diagnosis-Drum Brakes (Continued)

Condition	Possible Cause	Correction
<p>ALL BRAKES DRAG (ADJUSTMENT IS KNOWN TO BE CORRECT (Continued)</p>	<p>(4) Compensating or bypass port of master cylinder closed. (5) Use of inferior hydraulic fluid or rubber parts. (Swollen cups, corroded wheel or master cylinder bores.</p>	<p>(4) Open with compressed air. (5) Overhaul wheel and/or master cylinder.</p>
<p>BRAKE PEDAL TRAVEL DE- CREASING</p>	<p>(1) Master cylinder compensating port plugged. (2) Power unit bellcrank pivot pins binding (CJ only) or pedal pivot binding on manual brakes. (3) Swollen cup in master cylinder. (4) Master cylinder piston not returning. (5) Wheel cylinder pistons sticking.</p>	<p>(1) Use compressed air to unplug. (2) Lube pedal pivot or pivot pins. (3) Replace rubber parts. Flush system. (4) Overhaul master cylinder. (5) Overhaul wheel cylinder.</p>
<p>ONE WHEEL DRAGS</p>	<p>(1) Weak or broken brake shoe retracting springs. (2) Power unit bellcrank pivot pins binding (CJ only) or pedal pivot binding. (3) Insufficient brake shoe-to-drum clearance. (4) Loose wheel bearings. (5) Wheel cylinder piston cups swollen and distorted. (6) Pistons sticking in wheel cylinder. (7) Restriction in brake line. (8) Loose anchor pin. (9) Parking brake components seized or incorrectly adjusted.</p>	<p>(1) Replace the defective brake shoe springs and lubricate the brake shoe ledges. (2) Lube pedal pivot or pivot pins. (3) Adjust brakes. Repair automatic adjusters if necessary. (4) Adjust wheel bearings. (5) Overhaul wheel cylinders. (6) Clean or replace pistons; clean cylinder bore. (7) Clean out or replace. (8) Adjust and tighten lock nut. (9) Repair or replace parts as necessary.</p>
<p>ONE WHEEL LOCKS</p>	<p>(1) Contaminated linings. (2) Worn tire treads.</p>	<p>(1) Replace the linings. (2) Replace tire or, match up tire treads from side to side.</p>

Service Diagnosis-Drum Brakes (Continued)

Condition	Possible Cause	Correction
BRAKES GRAB OR WON'T HOLD IN WET WEATHER	<ul style="list-style-type: none"> (1) Linings water-soaked. (2) Dirt, water in drums. (3) Bent support plate allowing excessive water to enter drum. (4) Scored drums. 	<ul style="list-style-type: none"> (1) Dry out linings by driving with brakes lightly applied. (2) Clean drums. (3) Replace support plate. (4) Replace or resurface in pairs.
BRAKES SQUEAK	<ul style="list-style-type: none"> (1) Support plate bent or shoes twisted. (2) Metallic particles or dust imbedded in lining. (3) Lining rivets loose or lining not held tightly against the shoe at the ends. (4) Drums distorted. (5) Shoes scraping on support plate ledges. (6) Weak or broken hold-down springs. (7) Loose wheel bearings. (8) Charred lining. (9) Loose support plate, anchor, drum, or wheel cylinder. (10) Linings located wrong on shoes. 	<ul style="list-style-type: none"> (1) Replace damaged parts. (2) Sand the surfaces of the linings and drums. Remove all particles of metal that may be found in the surface of the linings. (3) Replace rivets. Replace shoe lining assemblies if damaged. (4) Turn or replace drums. (5) Lubricate. (6) Replace defective parts. (7) Adjust bearings. (8) Replace lining. (9) Tighten. (10) Install linings correctly.
REAR BRAKES DRAG	<ul style="list-style-type: none"> (1) Adjustment not correct. (2) Parking brake cables frozen. (3) Dirty lining. (4) Wheel cylinder cups swollen or piston sticking. (5) Weak retracting springs. (6) Shoes binding on support plate. 	<ul style="list-style-type: none"> (1) Adjust brake shoes and parking brake mechanism. (2) Lubricate or replace as required. (3) Replace lining. (4) Overhaul cylinders. (5) Replace springs. (6) Lubricate support plate ledges

Service Diagnosis-Drum Brakes (Continued)

Condition	Possible Cause	Correction
VEHICLE PULLS TO ONE SIDE	(1) Grease or fluid-soaked lining.	(1) Locate and correct leakage; replace linings.
	(2) Adjustment not correct.	(2) Adjust the brakes.
	(3) Loose wheel bearings, loose support plate(s) or loose spring bolts.	(3) Adjust wheel bearing; tighten support plate(s) and tighten spring bolts.
	(4) Linings not of specified kind or primary and secondary shoes reversed.	(4) Install new linings.
	(5) Power unit bellcrank pivot pins binding (CJ only).	(5) Lube pivot pins.
	(6) Tires not properly inflated or unequal wear of tread. Different tread design side to side.	(6) Inflate the tires to recommended pressures. Rotate tires so that tread surfaces of similar design and equal wear will be installed on the front wheels.
	(7) Water, mud, or foreign matter in brakes.	(7) Remove foreign material from brake parts and inside of the drums. Lubricate the shoe ledges and the rear brake cable ramps.
	(8) Wheel cylinder sticking.	(8) Overhaul or replace wheel cylinder.
	(9) Weak or broken retracting springs.	(9) Check springs. Replace bent, distorted or cracked springs.
	(10) Out-of-round drums.	(10) Resurface or replace drums in left and right hand pairs (both front and both rear).
	(11) Brake dragging.	(11) Check for loose lining. Repair or replace as required.
	(12) Broken spring or loose U-bolts.	(12) Replace spring or tighten U-bolts.
	(13) Loose steering components.	(13) Tighten or repair and adjust as required.
	(14) Unequal camber.	(14) Replace axle housing.
	(15) Clogged or crimped brake line.	(15) Repair or replace line.
	(16) Wheel cylinder incorrect size.	(16) Replace with correct cylinders.
	(17) Worn steering knuckle bearings.	(17) Replace.

Service Diagnosis-Drum Brakes (Continued)

Condition	Possible Cause	Correction
BRAKES CHATTER	(1) Incorrect lining-to-drum clearance. (2) Loose brake support plate. (3) Grease, fluid, road dust on lining. (4) Weak or broken retractor spring. (5) Loose wheel bearings. (6) Drums out-of-round. (7) Cocked or distorted shoes. (8) Tapered or barrel-shaped drums.	(1) Adjust to recommended clearances. (2) Tighten support plate. (3) Clean out dust; replace grease and fluid-soaked lining. (4) Replace. (5) Adjust. (6) Turn or replace drums in pairs. (7) Straighten or replace. (8) Turn or replace drums in pairs.
SHOE CLICK	(1) Shoes lift off support plate and snap back. (2) Holddown springs weak. (3) Shoe bent. (4) Grooves in support plate ledges.	(1) Change drums side to side or turn drums (in pairs). (2) Replace springs. (3) Replace shoes on both sides. (4) Replace support plate.

60637G

Service Diagnosis-Disc Brakes

Condition	Possible Cause	Correction
BRAKE CHATTER OR ROUGHNESS. BRAKE PEDAL PULSATES	(1) Excessive rotor lateral runout. (2) Excessive rotor thickness variation. (3) Loose or worn wheel bearings. (4) Rear drums out-of-round.	(1) Check rotor runout. Refinish if not to specs (refer to Rotor Measurements). Replace if unable to refinish. (2) Check rotor thickness variation. Refinish if out of spec. Replace if unable to refinish. (3) Adjust to specs. Replace if worn or damaged. (4) Check runout. If not to specs turn drum. Do not remove more than .060 inch (1.52 mm)

60638A

Service Diagnosis-Disc Brakes (Continued)

Condition	Possible Cause	Correction
BRAKE CHATTER OR ROUGHNESS. BRAKE PEDAL PULSATES (Continued)	(5) Disc brake shoes reversed (steel side of shoe riding on rotor). (6) Shoes bent or linings worn.	(5) Replace rotor and shoes. (6) Replace shoes.
EXCESSIVE PEDAL EFFORT REQUIRED	(1) Malfunction in power brake unit. (2) Malfunction in front or rear brake system (dual master cylinder) such as: wheel cylinder leaks, defective brake lines, caliper piston seal leak, master cylinder piston cups not holding pressure. (3) Lining worn. (4) Caliper piston sticking. (5) Brake fade caused by incorrect or non-recommended linings. (6) Incorrect master cylinder.	(1) Check operation. Refer to Power Brake Units. (2) Check both brake systems and correct as required. Check for failed brake warning light if brake failure occurred and light did not operate. (3) Check and replace linings as required. (4) Rebuild caliper. (5) Replace with correct or recommended lining. (6) Check and replace if required.
EXCESSIVE PEDAL TRAVEL	(1) Low fluid level. (2) Leak in system. (3) Air in system. (4) Rear brakes not adjusting properly. (5) Worn lining. (6) Bent or broken shoe. (7) Master cylinder mounting bolts loose. (8) Rotor thickness or drum diameter below specification.	(1) Add fluid as required. (2) Inspect and correct as required. (3) Bleed brakes. (4) Adjust rear brakes and repair automatic adjusters. (5) Replace linings. If wear is excessive or premature, check for incorrect lining, sticking caliper pistons, binding park brake cables, shoe drag on support plate, weak return springs on drum brakes, improper rear brake adjustment. (6) Replace as required. (7) Check and retighten. (8) Inspect, measure and replace as required.
DRAGGING BRAKES	(1) Master cylinder pistons not returning properly.	(1) Remove cover, check for spurt of fluid at compensator holes as brake pedal is depressed. Rebuild master cylinder if fluid spurt is not observed. Inspect compensator ports for blockage, use compressed air to clear passages.

NOTE: A very light drag occurring after releasing the brake pedal is a characteristic of disc brakes.

Service Diagnosis-Disc Brakes (Continued)

Condition	Possible Cause	Correction
	<p>(2) Restrictions in brake lines or hoses.</p> <p>(3) Incorrect parking brake adjustment.</p> <p>(4) Rear shoes not returning to normal position.</p> <p>(5) Caliper pistons not releasing. Pistons stuck due to piston scoring or corrosion or piston cocking in bore.</p> <p>(6) Lines to combination valve installed incorrectly.</p> <p>(7) Bind in brake pedal or power unit bellcrank pivot pins (CJ only)</p> <p>(8) Check valve installed in master cylinder outlet port.</p>	<p>(2) Check for kinks or dents in steel lines . Check rubber hoses for swelling or restrictions inside hose.</p> <p>(3) Check and readjust to specification. Inspect cables for bind or frayed conditions.</p> <p>(4) Return springs weak. Shoes dragging on support plate due to lack of lube or ridges on support plate ledges. Wheel cylinder cups swollen or pistons sticking. Repair or replace faulty parts as required.</p> <p>(5) Repair or replace pistons or caliper as required.</p> <p>(6) Check and correct as required. Port marked inlet goes to master cylinder; port marked outlet goes to calipers.</p> <p>(7) Lube pedal pivot or pivot pins.</p> <p>(8) Check outlet. Remove valve if present. Bleed brakes.</p>
GRABBING BRAKES	<p>(1) Refer to all conditions listed under PULLS WHEN BRAKES ARE APPLIED.</p> <p>(2) Power brake unit malfunction or bellcrank pivot pins binding (CJ only).</p> <p>(3) Combination valve malfunction.</p> <p>(4) Incorrect power unit.</p>	<p>(1) See PULLS WHEN BRAKES ARE APPLIED.</p> <p>(2) Check operation and replace or repair as required. Refer to POWER UNIT SERVICE DIAGNOSIS Chart.</p> <p>(3) Replace valve and bleed system.</p> <p>(4) Check and replace as required.</p>
PULLS WHEN BRAKES ARE APPLIED	<p>(1) Incorrect tire pressures.</p> <p>(2) Mismatched tires on same axle.</p> <p>(3) Wheel bearings misadjusted or worn.</p>	<p>(1) Inflate to spec.</p> <p>(2) Install equal size, type tires.</p> <p>(3) Adjust or replace as required.</p>

Service Diagnosis-Disc Brakes (Continued)

Condition	Possible Cause	Correction
	(4) Malfunction in caliper.	(4) Check for stuck piston.
	(5) Damaged or contaminated shoe and lining (grease on lining or bent shoe).	(5) Replace shoe and lining on both sides. Replace axle seals, wheel cylinder cups, or caliper piston seals, if leaking.
	(6) Rear brake problem: automatic adjusters inoperable, contaminated lining, defective wheel cylinders, seized or improperly adjusted park brake cables, shoes binding on support plate, linings worn, linings charred or cracked, bent support plate, weak retracting springs, drums out-of-round.	(6) Inspect and repair or replace malfunctioning parts. Check for equal size wheel cylinders on rear brakes.
	(7) Loose calipers.	(7) Check mounting bolt torque, inspect threads on bolts for galling or stripped threads, check support plate for broken welds.
	(8) Loose suspension parts.	(8) Inspect and correct as required.
	(9) Front end out of alignment.	(9) Check and correct as required.
	(10) Lining soaked with water after operation in heavy rains, or flooding conditions.	(10) Allow lining to air dry, or while driving, keep brakes lightly applied to warm up lining and evaporate water.
	(11) Disc brake rotor out of tolerance.	(11) Check and refinish or replace as required.
REAR DRUM BRAKES SKID PREMATURELY ON HARD BRAKE APPLICATION	(1) Combination valve proportioner section malfunctioning.	(1) Replace valve and bleed brakes.
	(2) Check items listed under PULLS and GRABBING.	(2) See PULLS and GRABBING.
SPONGY PEDAL	(1) Air in system.	(1) Bleed brakes. Inspect for broken lines, loose fittings, leaking caliper pistons, or wheel cylinders; check rubber seal on master cylinder cover. Check cover itself for distortion or cracks, check all bleed valves for proper torque.
	(2) Rear drums thin or cracked.	(2) Inspect and correct as required.
	(3) Calipers loose.	(3) Check mounting bolt torque.
	(4) Loose master cylinder or brake booster attaching parts.	(4) Check and correct as required.

Service Diagnosis-Disc Brakes (Continued)

Condition	Possible Cause	Correction
SPONGY PEDAL (Continued)	(5) Compensator port blocked in master cylinder.	(5) Check and correct as required.
	(6) Improper (low quality) brake fluid in system. Fluid boils and becomes aerated.	(6) Drain and flush system.

60638E

BRAKE PEDAL

A suspended brake pedal is used on all models. The pedal is attached to the pedal support bracket by a pivot bolt (figs. 2G-1 and 2G-2). The pivot bolt serves as both attaching part and pivoting member for the pedal.

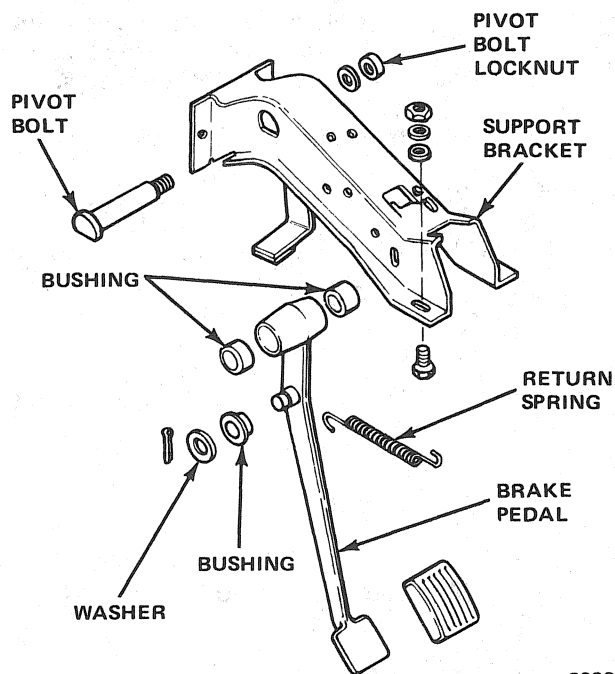

80338

Fig. 2G-1 Brake Pedal—CJ Models

The pedal linkage should be lubricated and inspected regularly for binding, looseness, or excessive play. Binding can cause improper pedal release which may result in brake drag and rapid lining wear. In addition, worn pedal linkage may cause a low pedal condition or frequent need for brake adjustment.

Pedal free play should be 1/16 to 1/4 inch (1.58 to 6.35 mm). Inadequate free play can result in brake drag or grab while excessive free play can produce a low pedal condition. Free play on models with nonpower brakes is governed by pedal push rod length which is preset at manufacture. The push rod is not adjustable on these

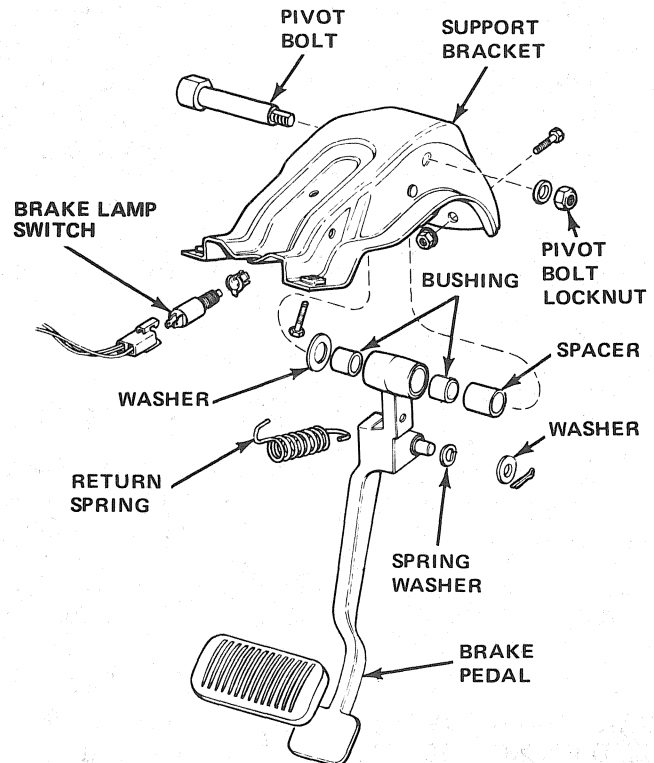

80337

Fig. 2G-2 Brake Pedal—Cherokee-Wagoneer-Truck Models

models and under normal circumstances should not require further attention. Power brake equipped vehicles utilize a single push rod in the power unit which is also preset at manufacture and is not adjustable. When replacing a power unit, use the push rod supplied with the replacement power unit as it has been properly gauged for use with the replacement unit. Pedal free play for power brake equipped vehicles is the same as for vehicles with nonpower brakes.

BRAKE WARNING LAMP

A dual purpose warning lamp is located in the instrument cluster on all Jeep vehicles. The primary function of this lamp is to alert the driver if a pressure

differential between front and rear brake hydraulic systems should ever occur.

On vehicles with a parking brake warning system, the lamp also functions as a signal device to alert the driver when the parking brakes are applied.

In the parking brake signal mode, the lamp is activated by a mechanically operated switch mounted on the parking brake lever assembly. In the brake hydraulic pressure differential warning mode, the lamp is activated by a plunger-type switch located in the combination valve.

If a pressure loss should occur in either the front or rear brake hydraulic systems, a pressure differential of 70 to 300 psi (483 to 2 068 kPa) will cause a piston in the pressure differential section of the combination valve to shuttle toward the low pressure side of the valve. As the piston moves toward this side of the valve, ramps on the piston contact the differential switch plunger forcing it upward and closing the switch internal contacts. This completes the electrical circuit between switch and warning lamp causing the lamp to light. Unless the ignition lock cylinder is turned to the Off position, the

lamp will remain illuminated until the cause of the pressure differential is corrected.

In normal operation, with the ignition lock cylinder turned to the Start Position, the warning lamp will illuminate and remain so until the engine is started and the lock cylinder is returned to the On position, or when the parking brakes are released. This feature is provided as a means of checking warning lamp bulb and circuit operation.

PARKING BRAKE ADJUSTMENT

NOTE: *The service brakes must be adjusted before adjusting the parking brakes.*

- (1) Release parking brakes.
- (2) Loosen equalizer locknuts to release tension on cables (figs. 2G-3 and 2G-4).
- (3) Inspect all cables for binds, kinks, or frayed condition. Replace damaged cables.
- (4) Tighten equalizer locknut until slight drag is produced at wheels.
- (5) Loosen equalizer locknut until wheels rotate freely and brake drag is eliminated.

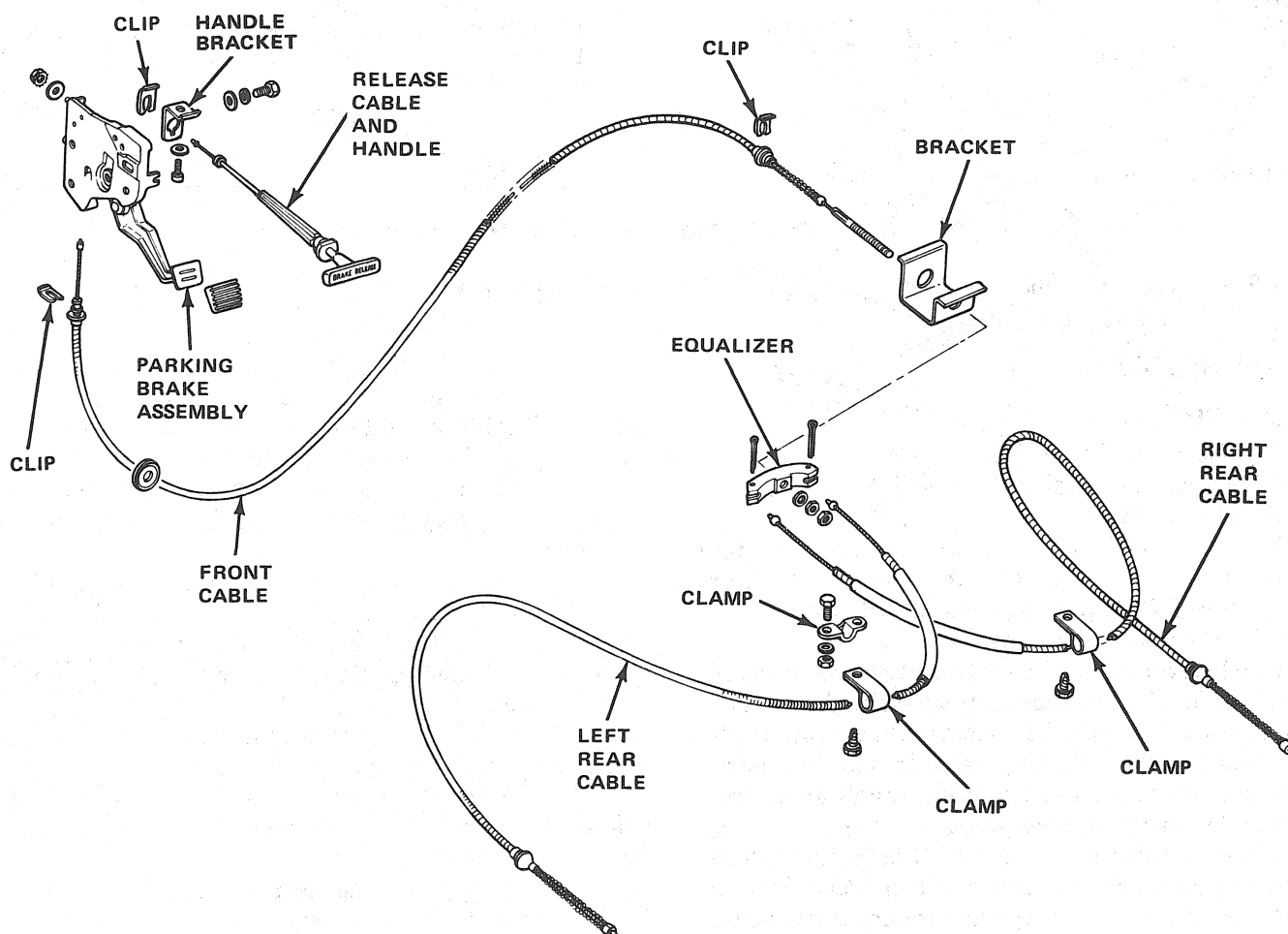

Fig. 2G-3 Parking Brake Assembly—CJ Models

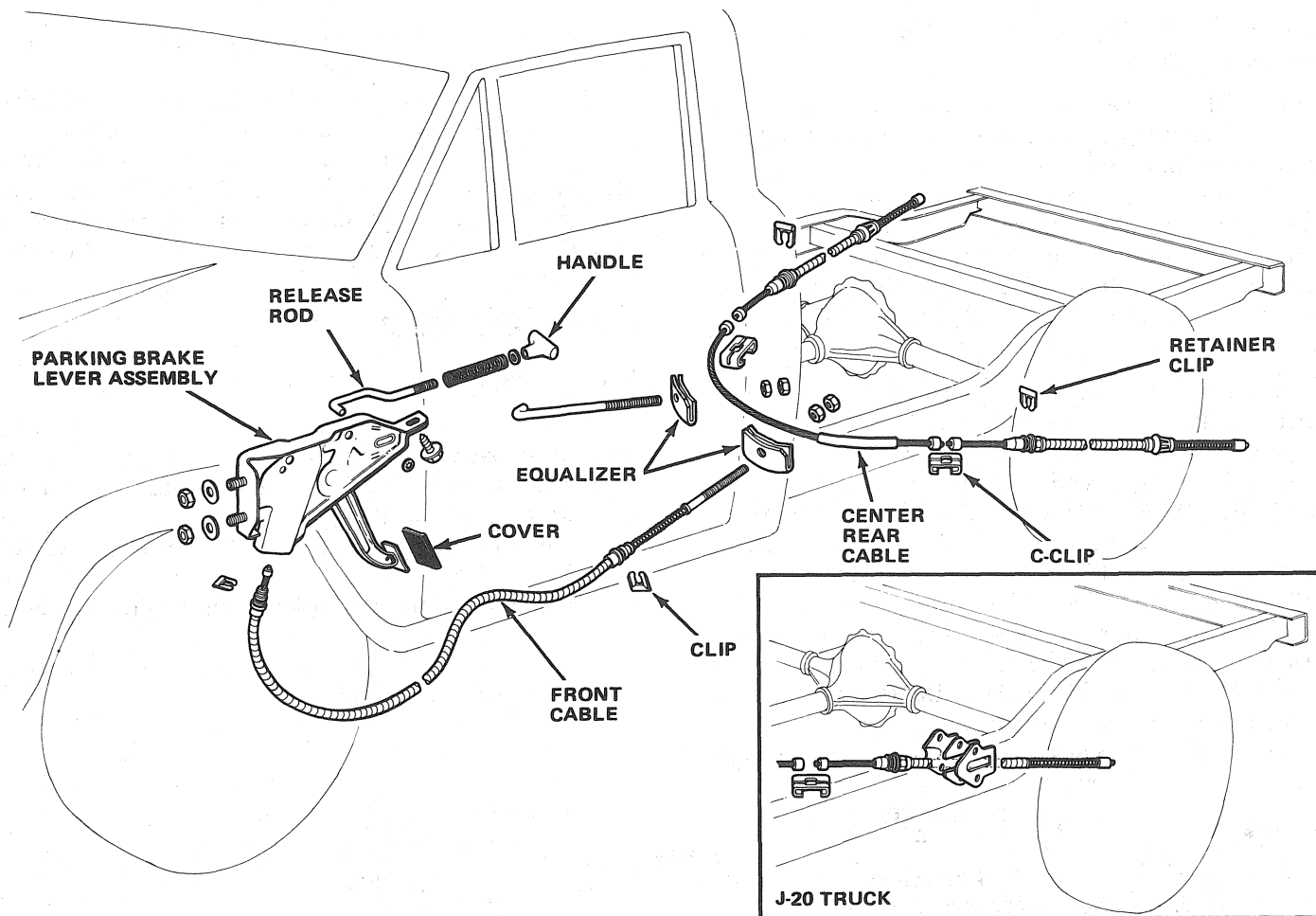

Fig. 2G-4 Parking Brake Assembly—Cherokee-Wagoneer-Truck Models

80339

- (6) Tighten equalizer locknuts securely.
- (7) Check parking brake operation.

PARKING BRAKE CABLES

Removal—Rear Cable

- (1) Raise vehicle.
- (2) Loosen cable adjuster locknuts at equalizer (figs. 2G-2 and 2G-3).
- (3) On CJ models, remove necessary cable locating clamps, remove cotter pin retaining cable in equalizer, and remove cable end from equalizer (fig. 2G-3).
- (4) On Cherokee, Wagoneer and Truck models, disengage cable from connector attached to center cable.
- (5) On Cherokee, Wagoneer and Truck models, if left cable is being removed, remove fuel tank skid plate.
- (6) Remove clip retaining cable in frame bracket and unhook locating spring from cable (fig. 2G-4).
- (7) Disassemble necessary rear drum brake unit as outlined in this chapter.
- (8) On all vehicles except those with Model 60 rear axle, compress cable lock tabs at brake support plate using small hose clamp and remove cable. On vehicles with Model 60 rear axle, remove bolts attaching cable mounting bracket to support plate and remove cable.

Installation—Rear Cable

- (1) On all vehicles except those with Model 60 rear axle, insert cable in support plate and pull cable through plate until cable lock tabs engage in support plate.
- (2) On vehicles with Model 60 rear axle, insert cable end through support plate, position cable mounting bracket on support plate, and install mounting bracket attaching bolts.
- (3) Reassemble rear drumbrake unit as outlined in this chapter.
- (4) On CJ models, engage cable end in equalizer, install cable retaining cotter pin, and install necessary cable locating clamps.
- (5) On Cherokee, Wagoneer and Truck models, engage cable end in center cable connector.
- (6) Insert cable in frame bracket, install cable-to-bracket retainer clip in cable ferrule, and engage cable end in center cable connector.
- (7) On Cherokee, Wagoneer and Truck models, install fuel tank skid plate if removed.
- (8) Tighten cable adjuster locknuts and adjust parking brakes as outlined in this chapter.
- (9) Lower vehicle.

Removal—Front Cable

- (1) Raise vehicle.
- (2) Remove equalizer from front cable.
- (3) On CJ models, remove clip retaining cable to frame bracket.
- (4) On Cherokee, Wagoneer and Truck models, remove clip retaining cable to rear crossmember.
- (5) Lower vehicle.
- (6) Disconnect front cable return spring at parking brake lever assembly if equipped.
- (7) Roll carpet back and remove front cable ferrule-to-parking brake lever assembly retaining clip.
- (8) Disengage cable end from parking brake lever assembly.
- (9) Remove cable.
- (10) If cable is to be replaced, remove insulator or grommet from lever end of cable.

Installation—Front Cable

- (1) Install front cable through floorpan and install cable grommet or insulator in floorpan.
- (2) Install cable ferrule-to-parking brake lever assembly retaining clip and reposition carpet.
- (3) Engage cable end in parking brake lever assembly and install cable return spring if equipped.
- (4) On CJ models, install clip retaining cable to frame bracket.
- (5) On Cherokee, Wagoneer and Truck models, install clip retaining cable to rear crossmember.
- (6) Raise vehicle.
- (7) Install cable equalizer and locknuts. On CJ models, be sure cable is properly positioned in frame bracket as well as equalizer (fig. 2G-3).
- (8) Adjust parking brakes as outlined in this section.
- (9) Lower vehicle.

BRAKELAMP SWITCH

The brakelamp switch is mounted on a flange attached to the brake pedal support bracket (fig. 2G-2). A spring-loaded plunger in the switch opens and closes the stoplamp circuit.

When the brake pedal is in the released position, the pedal arm contacts the switch plunger, holding it in the off position. When the brake pedal is pressed, the spring loaded plunger extends with brake pedal movement until the switch is in the On position.

Brakelamp Switch Adjustment

- (1) On CJ models with air conditioning, remove screws attaching evaporator housing to instrument panel and move housing away from panel.
- (2) Press and hold brake pedal in applied position.
- (3) Push brakelamp switch through mounting bracket until it stops against brake pedal bracket.

(4) Release brake pedal to set switch in proper position.

(5) Check switch position. Switch plunger should be in ON position and activate brakelamps after 3/8 to 5/8 inch (9.52 to 15.87 mm) brake pedal travel. Measure pedal travel from center of brake pedal pad.

(6) On CJ models with air conditioning, reposition evaporator housing on panel and install housing attaching screws.

SERVICE BRAKE ADJUSTMENT

The rear drum brakes are the only adjustable service brakes on Jeep vehicles. If the rear brakes are disassembled for any reason, an initial adjustment must be performed before installing the drum. In addition, if diagnosis indicates the need, the rear brakes can be adjusted manually as follows:

(1) To perform initial adjustment with drums removed, use Brakeshoe-to-Drum Clearance Gauge J-21107-01 to preset brakelining adjustment (fig. 2G-5).

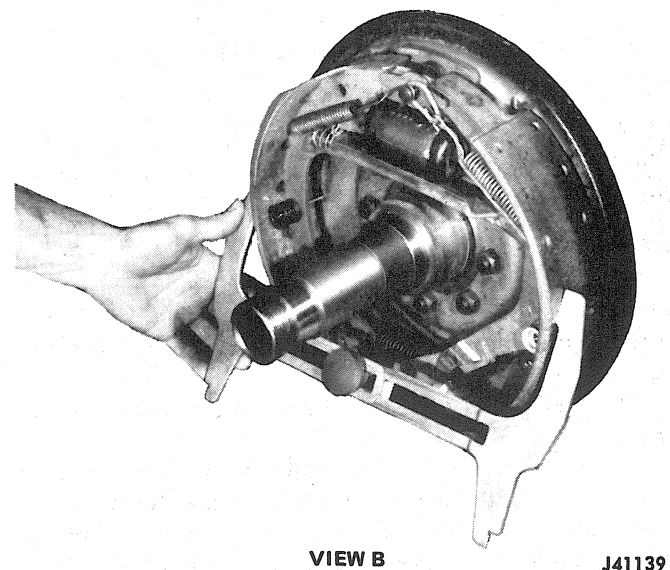
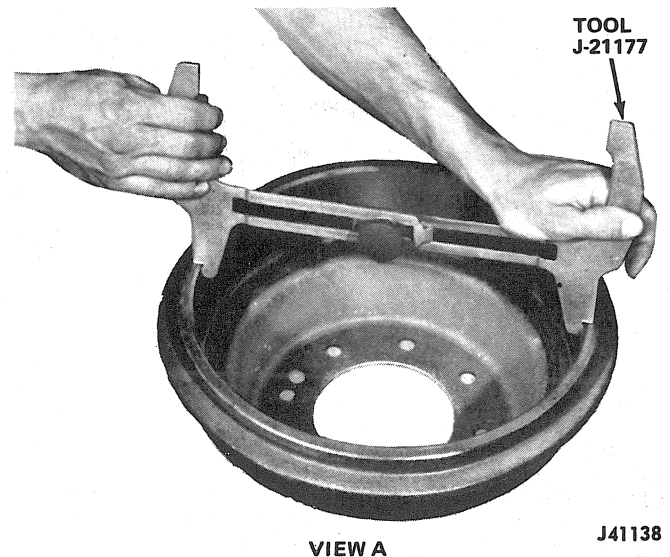

Fig. 2G-5 Presetting Brakeshoe-To-Drum Clearance

Drums should fit over brakelining with slight drag.

(2) To manually adjust rear brakes with drums in place, proceed to next step.

(3) Remove access slot covers from brake support plates.

(4) Rotate adjusting screw in clockwise direction using brake adjusting tool until brakes are locked.

(5) Rotate adjuster screw in counterclockwise direction until wheel rotates freely (fig. 2G-6).

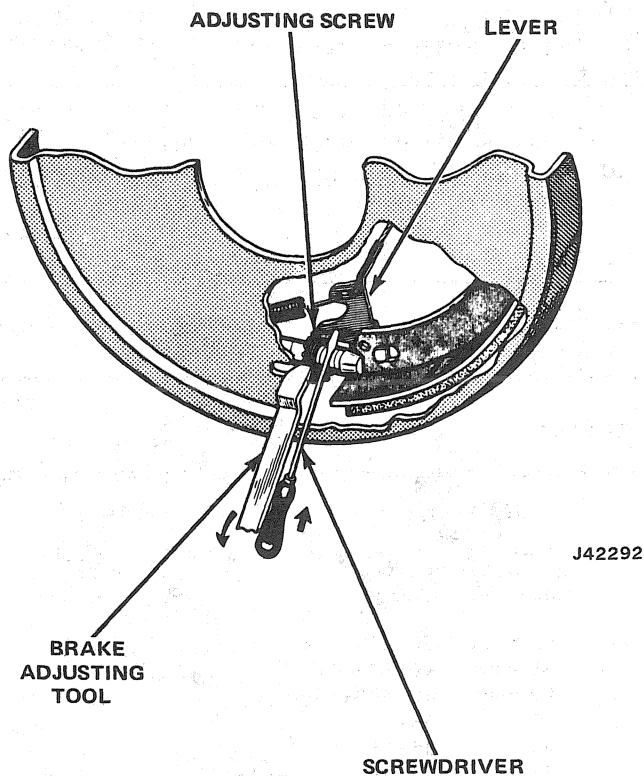

Fig. 2G-6 Adjusting Drum Brakes Manually

CAUTION: The automatic adjuster lever must be disengaged from the adjuster screw before the screw can be rotated. Use a thin blade screwdriver or section of 1/8 welding rod to unseat the adjuster lever (fig. 2G-6).

(6) Install access slot cover in brake support plate.

(7) Check brake operation before moving vehicle.

(8) Complete rear brake and pedal travel adjustment by driving vehicle in reverse and making 10 to 15 firm brake applications. Make one forward brake application between each reverse application to equalize adjustment.

BRAKELINING INSPECTION

Disc Brakes

The brakelining should be inspected whenever the wheels are removed for tire rotation or at the intervals specified in the Maintenance Schedule.

It is not necessary to remove the front calipers for brakelining inspection. The outboard lining can be viewed from either end of the caliper and the inboard lining can be viewed through the inspection port in the caliper body (fig. 2G-7). The lining should be replaced when it has worn to the approximate thickness of the metal brakeshoe.

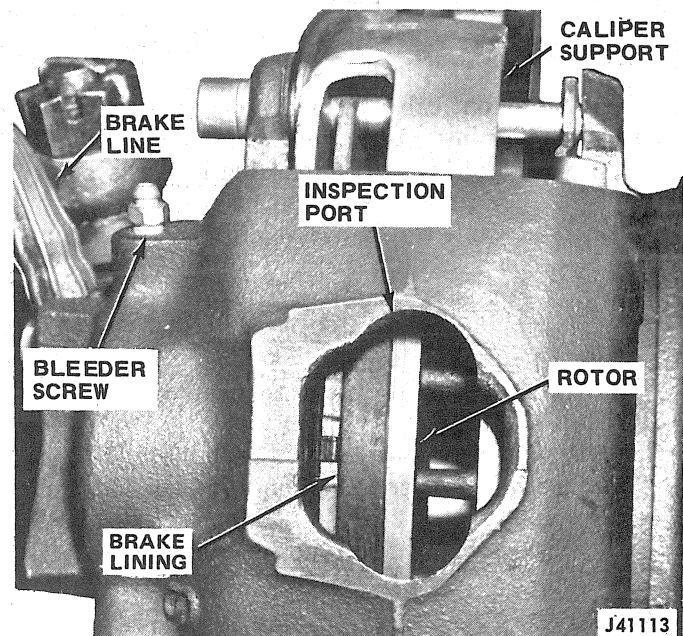

Fig. 2G-7 Caliper Inspection Port

NOTE: The disc brakeshoes used on Cherokee, Wagoneer and Truck models have a wear sensor attached to the inboard brakeshoe. When the lining wears sufficiently, the sensor contacts the rotor making a high pitched noise to warn the driver that replacement is necessary.

Drum Brakes

Inspect the rear drum brakelining whenever the rear wheels and drums are removed or at the intervals specified in the Mechanical Maintenance Schedule. Bonded linings should be replaced whenever the lining has worn to a thickness of 1/16 inch (1.58 mm) or less. Riveted linings should be replaced whenever the lining has worn to within 1/32 inch (0.79 mm) of the rivet heads.

SPECIFICATIONS

Brake Size and Application Chart

Model	Master Cylinder Bore Diameter	Front Brakes		Rear Brakes		Power Brake Unit Type
		Brake Size And Type	Caliper Piston Diameter	Brake Size And Type	Wheel Cyl. Diameter	
CJ	1.00 (25.4 mm)	11.7 Disc. (29.7 cm)	2.6 Single Piston (6.60 cm)	10 x 1.75 Drum (25.4 x 4.44 cm)	.875 (22.2 mm)	8.00 Single Diaphragm (20.3 cm)
Cherokee Wagoneer	1.125 (28.5 mm)	12.0 Disc. (30.48 cm)	2.937 Single Piston (7.45 cm)	11 x 2 Drum (27.94 x 5.08 cm)	.937 (23.79 mm)	9 1/2 Single Diaphragm (24.13 cm)
J-10 Truck	1.125 (28.5 mm)	12.0 Disc. (30.48 cm)	2.937 Single Piston (7.45 cm)	11 x 2 Drum (27.94 x 5.08 cm)	.937 (23.79 mm)	9 1/2 Single Diaphragm (24.13 cm)
J-20 Truck 6800 GVW	1.125 (28.5 mm)	12.5 Disc. (31.75 cm)	2.937 Single Piston (7.45 cm)	12 x 2.5 Drum (30.48 x 6.35 cm)	1.125 (28.5 mm)	9 1/2 Tandem Diaphragm (24.13 cm)
J-20 Truck 7600 GVW	1.125 (28.5 mm)	12.5 Disc. (31.75 cm)	2.937 Single Piston (7.45 cm)	12 x 2.5 Drum (30.48 x 6.35 cm)	1.125 (28.5 mm)	9 1/2 Tandem Diaphragm (24.13 cm)
J-20 Truck 8400 GVW	1.125 (28.5 mm)	12.5 Disc. (31.75 cm)	2.937 Single Piston (7.45 cm)	12 x 2.5 Drum (30.48 x 6.35 cm)	1.125 (28.5 mm)	9 1/2 Tandem Diaphragm (24.13 cm)

41102

Torque Specifications

Service Set-To Torques should be used when assembling components. Service In-Use Recheck Torques should be used for checking a pre-torqued item.

	USA (ft -lbs)		Metric (N-m)	
	Service Set - to Torque	In - Use Recheck Torque	Service Set - to Torque	In - Use Recheck Torque
Brakeline-to-Caliper Fitting Bolt (Cke, Wag, Trk)	160 in-lbs.	120 - 200 in-lbs.	18	14 23
Bleeder Screw (1/4 - 28)	45 in-lbs.	40 - 50 in-lbs.	5	5 - 6
Bleeder Screw (3/8 - 24)	90 in-lbs.	40 - 140 in-lbs.	10	5 16
Brake Support Plate Mounting Bolts/Nuts (J-20 Trk)	50	45 - 55	68	61 - 75
Brake Support Plate Mounting Bolts/Nuts (Cke, Wag, J10 Trk)	45	35 - 55	61	47 - 75
Brake Support Plate Mounting Bolts/Nuts (CJ)	33	30 - 35	45	41 - 47
Caliper Anchor Bracket to Steering Knuckle (CJ)	85	75 - 95	115	102 - 129
Master Cylinder Mounting Bolts/Nuts	30	25 - 35	41	34 - 47
Master Cylinder-to-Power Unit Mounting Nuts	25	20 - 30	34	27 - 41
Power Brake Unit-to-Dash Mounting Bolts/Nuts	22	18 - 25	30	24 - 34
Brake Line-to-Caliper Fitting Bolt (CJ)	25	20 - 30	34	27 - 41
Brake Line-to-Wheel Cylinder Fitting	160 in-lbs.	120 - 200 in-lbs.	18	14 23
Parking Brake Cable Clamp-to-Support Plate Bolts (5/16 - 18)	10	8 - 12	14	11 - 16
Wheel Nuts (CJ)	75	65 - 90	102	88 - 122
Wheel Nuts (Cke, Wag, Trk)	75	65 - 80	102	88 - 108
Wheel Nuts (8400 GVW Trk)	130	110 - 150	176	149 - 203
Brake Pedal-to-Power Unit Push Rod Bolt/Nut	35	25 - 40	47	34 - 54
Caliper Mounting Bolts (Cke, Wag, Trk)	35	30 - 40	47	41 - 54
Caliper Support Key Retaining Screw (CJ)	15	15 - 18	20	20 - 24
Disc. Brake Shield Bolts (Cke, Wag, Trk)	8	5 - 10	11	7 - 14
Disc. Brake Shield Nuts (Cke, Wag, Trk)	35	30 - 40	47	41 - 54
Wheel Bearing Outer Locknut (All)	50(min.)		68 (min.)	
Wheel Bearing Inner Locknut (Bearing Adjuster):				
CJ	Tighten to 50 ft-lbs. (68 N-m) and back off 1/3 turn while rotating wheel.			
Cke, Wag, Trk	Tighten to 50 ft-lbs. (68 N-m), loosen and retighten to 35 ft-lbs. (47 N-m), then back off 1/3 turn - all while rotating wheel.			

All Torque values given in foot-pounds and newton-meters with dry fits unless otherwise specified.

60647

BRAKE HYDRAULIC SYSTEM

	Page
Brake Bleeding	2G-27
Brake Fluid	2G-20
Brake Fluid Level	2G-21
Combination Valve	2G-26
General	2G-20

	Page
Hydraulic System Inspection	2G-21
Master Cylinder	2G-21
Specifications	2G-29
Wheel Cylinder	2G-25

GENERAL

The brake hydraulic system consists of the dual reservoir master cylinder, combination valve, front disc brake calipers, rear drum brake wheel cylinders, and the connecting brake lines, hoses, and fittings (fig. 2G-8).

The hydraulic system is a closed system and must remain free of contaminants in order to function properly. When servicing the system, prevent the entry of contaminants by capping all lines and ports, and by avoiding the use of cleaning solvents that have a mineral oil base.

CAUTION: *Never use gasoline, kerosene, carbon tetrachloride, paint thinner, alcohol, or any similar fluid containing mineral oil, to clean or lubricate hydraulic*

system components. These materials will cause swelling, deterioration, and premature aging of rubber parts. Use brake fluid or brake cleaning solvent only.

To determine if dirt, moisture, or mineral oil base fluids have contaminated the hydraulic fluid, drain off a sample and check for suspended particles, discoloration, or separation of the fluid into distinct layers. Layering indicates the presence of water or mineral oil. If system contamination should occur, drain and flush the entire brake hydraulic system with an approved brake fluid only.

BRAKE FLUID

When refilling or adding brake fluid to the hydraulic system, use Jeep Brake Fluid or equivalent grade marked SAE J1703 or DOT 3 only. Do not use any brake

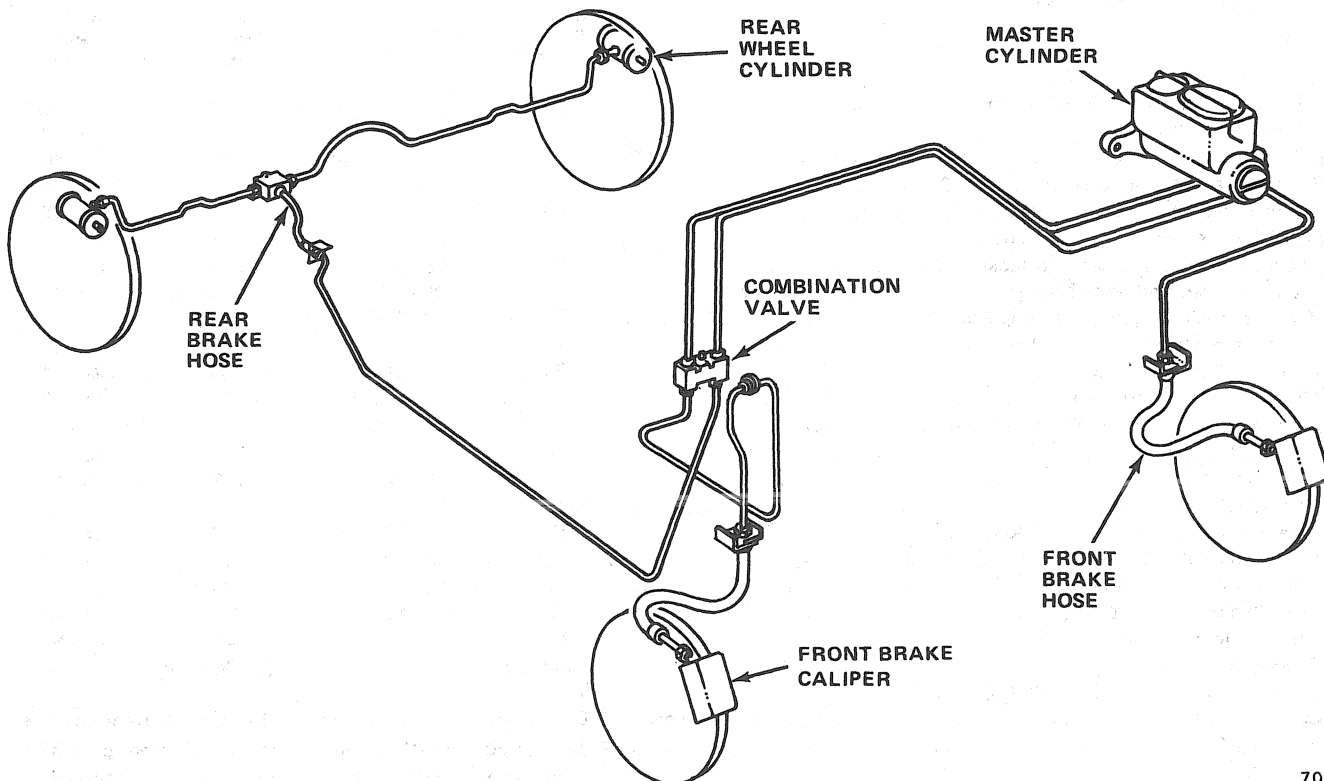

Fig. 2G-8 Brake Hydraulic System—Typical

fluid that does not have these grade markings. The use of nonapproved fluids can result in low fluid levels, spongy pedal, fluid aeration, brake fade, and deterioration of brake system components.

CAUTION: *Never refill or add used or reclaimed brake fluid to the hydraulic system.*

BRAKE FLUID LEVEL

The master cylinder fluid level should be checked at least four times a year or every 5,000 miles (8 046 km). Refer to the Maintenance Schedule for details.

When refilling or adding fluid to the system, fill the master cylinder fluid reservoirs to within 1/4 inch (6.35 mm) of each reservoir rim. This is the proper fluid level for all Jeep vehicles.

When checking the fluid level, also inspect the rubber diaphragm seal on the cylinder cover for cracks, cuts, distortion, or any other condition that might allow air or foreign material to enter the master cylinder reservoirs. In addition, when the cover is removed for any reason, do not allow the seal to contact dirt, grease, or other foreign material which could be transferred to the fluid reservoirs.

HYDRAULIC SYSTEM INSPECTION

(1) Clean master cylinder and cylinder cover thoroughly before checking fluid level.

(2) Check master cylinder cover retaining spring for proper tension and fit. Spring should provide enough tension on cover to maintain airtight seal.

(3) Remove cylinder cover and inspect cover and rubber diaphragm seal for cracks and distortion.

(4) Check master cylinder fill level.

(5) Check for dirt and foreign material in reservoirs. If fluid contamination is suspected, drain fluid sample into clean glass container and test for contamination as evidenced by fluid layering.

(6) Inspect all fittings and brake lines for leakage, kinks, or other damage.

(7) Inspect condition of front brake hoses. Replace hoses if cut, cracked, swollen, or leaking.

(8) Check for evidence of fluid leakage at rear wheel cylinders and front calipers. Repair as necessary.

MASTER CYLINDER

A dual reservoir master cylinder is used on all Jeep vehicles. The hydraulic system for the front brakes is

completely separate from the rear brakes. In the event of hydraulic brake failure in the front system, the rear hydraulic brakes will still operate. If a failure occurs in the rear brakes, the front brakes will still operate.

The dual master cylinder has two outlet ports, two fluid reservoirs, and two hydraulic pistons which are operated in tandem by a single push rod.

When the master cylinder fluid reservoirs are filled and the front and rear brake systems purged of air, there is a solid column of fluid on the forward side of both the primary and secondary pistons.

During brake application, fluid is displaced by the master cylinder pistons into the front caliper and rear wheel cylinders to activate the brakes. At brake release, fluid returns from the calipers and wheel cylinders to the master cylinder reservoirs.

Cherokee, Wagoneer and Truck models are equipped with a master cylinder designed to be compatible with the low drag disc brake calipers now used on these vehicles. This unit incorporates a quick take-up feature which means the master cylinder delivers a large volume of brake fluid (at low pressure) to the wheel brakes upon initial brake application. This fluid quickly displaces the retracted caliper and rear wheel cylinder pistons which position the brake linings in contact with the brake rotors and drums.

Master Cylinder Service—All Models

Removal

(1) Disconnect brake lines at master cylinder. Cap or tape outlet ports in master cylinder and open ends of brake lines to prevent entry of dirt.

(2) On models with nonpower brakes, disconnect master cylinder push rod at brake pedal.

(3) Remove bolts or nuts attaching master cylinder to dash panel or power unit and remove master cylinder.

Disassembly

(1) Remove cover and diaphragm seal and drain fluid from master cylinder. Mount master cylinder in vise.

NOTE: *On Cherokee, Wagoneer and Truck models:*

A. *Remove reservoir using pry bar (fig. 2G-9).*

B. *Remove reservoir grommets.*

C. *Remove retaining ring and quick take-up valve.*

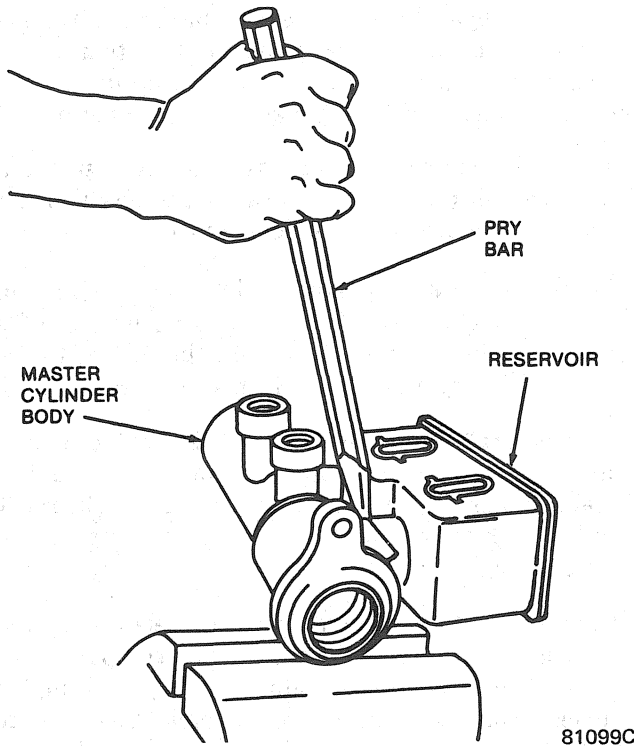

**Fig. 2G-9 Removing Master Cylinder
—Cherokee-Wagoneer-Truck Models**

(2) On models with nonpower brakes, remove boot (figs. 2G-10 and 2G-11).

(3) Push primary piston inward using wood dowel or push rod and remove snap ring from groove in master cylinder bore.

(4) Remove primary and secondary piston assemblies from cylinder bore. Air pressure applied through compensator port in front reservoir will aid in removal of secondary piston assembly.

(5) On CJ models, remove push rod from primary piston as follows:

(a) Clamp push rod in vise with brake pedal eyelet facing downward and rear face of primary piston positioned just above vise jaws.

(b) Pry piston off push rod using suitable tool inserted between piston and vise.

(c) Remove rubber insert from primary piston and discard insert. It is not reusable.

CAUTION: *The rubber insert which retains the push rod in the primary piston on CJ models will be damaged when the piston is removed from the push rod. Do not attempt to reuse this insert. A replacement insert must be installed at assembly.*

(6) Remove piston seal and piston cups from secondary piston only. It is not necessary to disassemble primary piston as piston is supplied as complete assembly in repair kit.

(7) Clean and inspect master cylinder. Replace unit if bore is severely scored, corroded, or pitted, or if body is cracked, porous, or has sustained other damage. Check compensator and bypass ports in reservoirs. If plugged or dirty, open them using brake cleaning solvent and air pressure only. Never use wire to open ports as wire may create burr in port and push burr into cylinder bore.

CAUTION: *Clean the master cylinder with brake fluid or an approved brake cleaning solvent only. Never use solvents containing mineral oil such as gasoline, kerosene, alcohol, or carbon tetrachloride. Mineral oil is very harmful to the rubber piston cups and seals.*

(8) Inspect tube seats in outlet ports. Replace seats only if cracked, scored, cocked in bore, or loose. If replacement is necessary, remove seats as follows:

(a) On Cherokee, Wagoneer and Truck models, thread 6-32 x 5/8 self-tapping screw into tube seat. Pry upward on screw using two screwdrivers to remove seat. Remove chips using brake cleaning solvent.

(b) On CJ models, enlarge hole in tube seats using 13/64 drill. Place flat washer on each outlet port and thread 1/4-20 x 3/4 screw into seat. Tighten screw until seat is loosened. Remove seat, screw, and washer. Remove chips using brake cleaning solvent and compressed air.

Assembly

(1) Install replacement tube seats (if removed) using spare tube fitting nuts to press seats into place. Do not allow seats to become cocked during installation. Be sure seats are bottomed. Remove tube fitting nuts and check for burrs or chips. Remove burrs or chips. Rinse master cylinder in brake cleaning solvent and blow out all passages with compressed air.

(2) Install piston cups on secondary piston. Piston cup installed in groove at end of piston should have lip facing away from piston. Install next cup so lip faces piston (figs. 2G-10 and 2G-11).

(3) Install seal protector, piston seal, spring retainer, and return spring on secondary piston (figs. 2G-10 and 2G-11). Install piston seal so lip faces interior of master cylinder bore when assembly is installed. Be sure return spring seats against retainer and that retainer is located inside lip of piston seal.

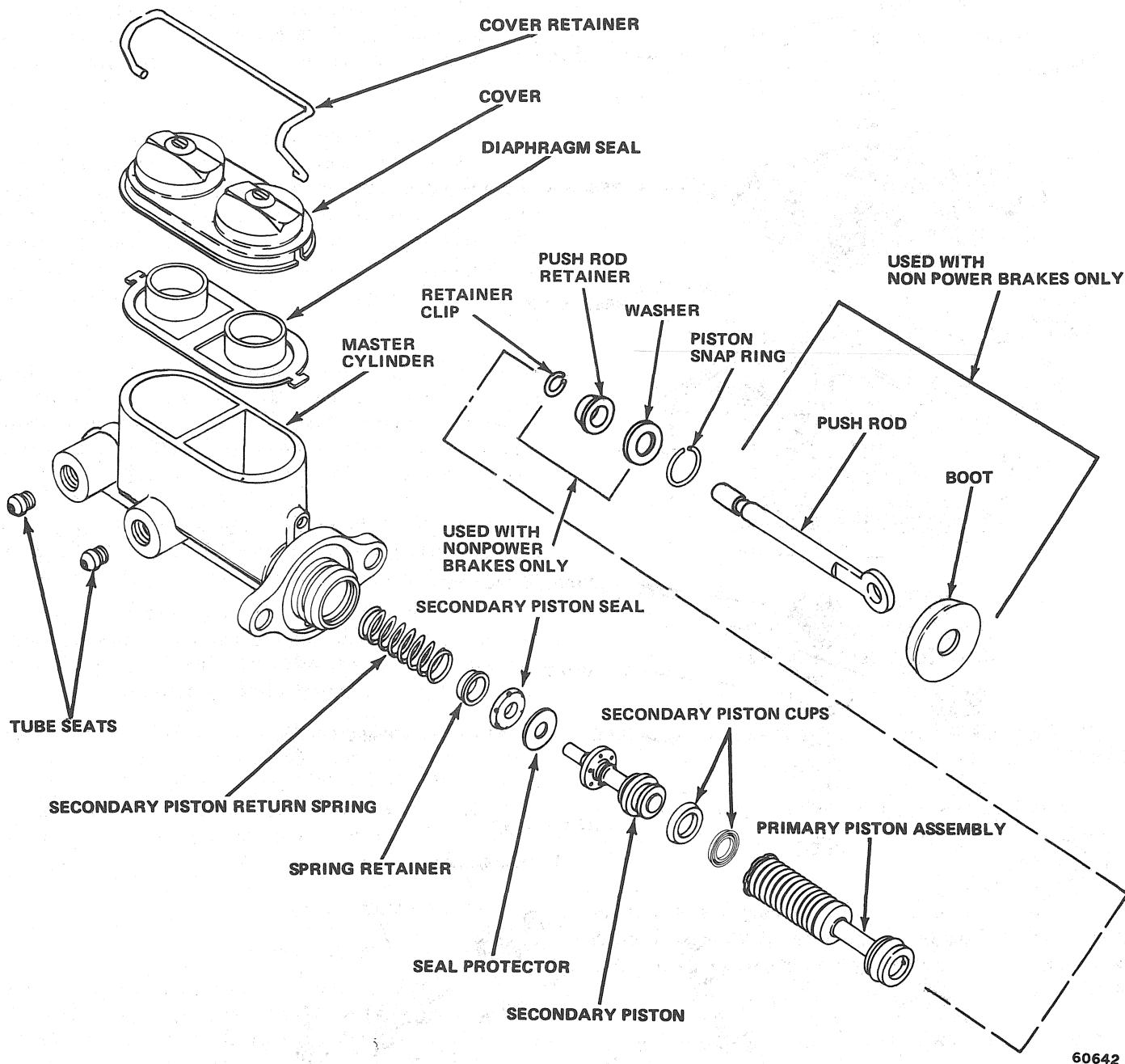

60642

Fig. 2G-10 Master Cylinder—CJ Models

(4) Lubricate master cylinder bore and secondary piston seal and cups with clean brake fluid and install secondary piston assembly in cylinder bore.

(5) Lubricate seals on primary piston assembly with clean brake fluid and install assembly in master cylinder bore.

(6) On Cherokee, Wagoneer, and Truck models:

(a) Press primary piston inward using wood dowel and install snap ring in groove of master cylinder bore.

(b) Install quick take-up valve and secure with retaining ring. Be sure retaining ring is properly seated in master cylinder body groove.

(c) Install new reservoir grommets in master cylinder body. Be sure grommets are properly seated.

(d) Lay reservoir on flat, hard surface (fig. 2G-12). Press master cylinder onto reservoir using rocking motion.

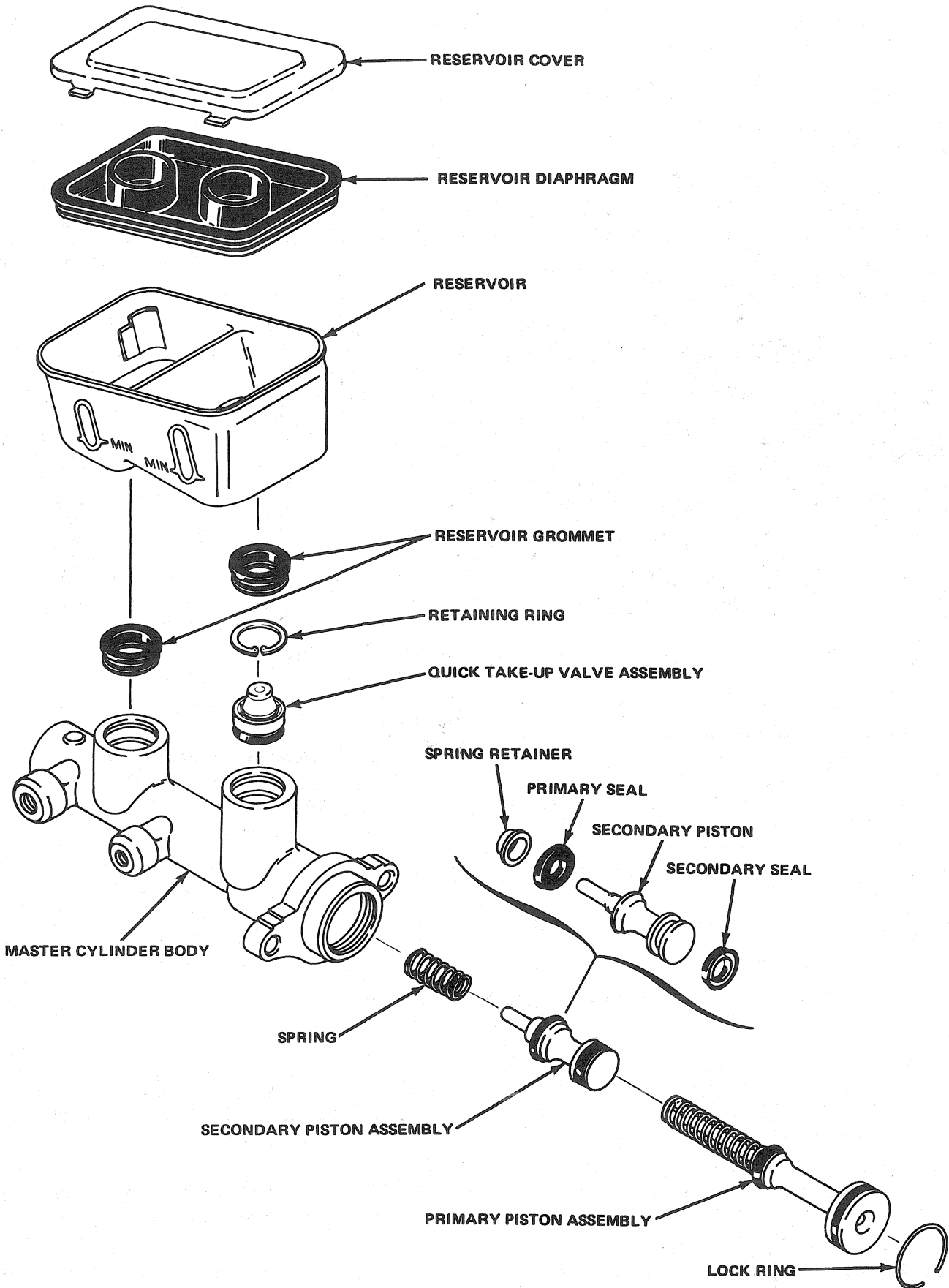
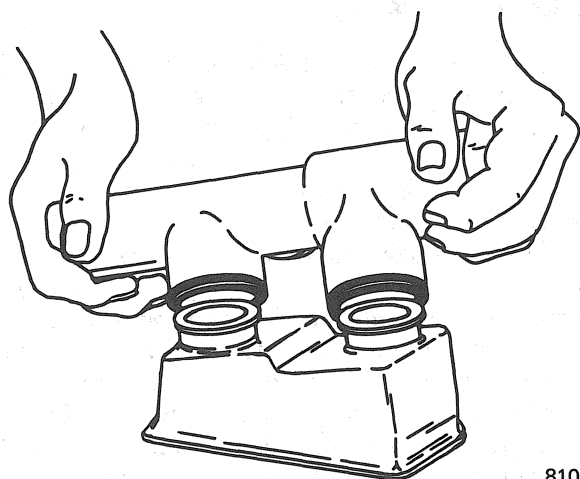

Fig. 2G-11 Master Cylinder—Cherokee-Wagoneer-Truck Models



81099D

**Fig. 2G-12 Installing Master Cylinder Reservoir—
Cherokee-Wagoneer-Truck Models**

(7) On CJ models, press primary piston inward using push rod and install snap ring in groove of master cylinder bore. Then continue pressing push rod into primary piston until rod is seated in rubber insert.

(8) On models with nonpower brakes, install boot.

(9) Install replacement diaphragm seal on master cylinder cover.

(10) Remove master cylinder from vise.

Installation

(1) Position master cylinder on dash panel or power unit and install attaching nuts and washers. Tighten nuts to 30 foot-pounds (41 N•m) torque.

(2) Connect brake lines to master cylinder.

(3) Fill master cylinder reservoirs to within 1/4 inch (6.35 mm) of rim with Jeep Brake Fluid or equivalent grade marked SAE J-1703 or DOT 3.

(4) Install cover and diaphragm seal.

(5) On models with nonpower brakes, connect push rod to brake pedal.

(6) Bleed entire brake system as outlined under Brake Bleeding.

WHEEL CYLINDER

The rear drum brake wheel cylinder consists of a cast iron housing with a piston bore machined in it. Two opposed pistons, rubber piston cups, and a compression spring with integral cup expanders are contained within the piston bore (fig. 2G-13). Rubber dust boots are installed at each end of the cylinder to prevent entry of dirt and water. Each cylinder is equipped with a bleeder screw to facilitate brake bleeding.

The compression spring is used to hold the piston cups tightly against the pistons and the integral cup expanders hold the piston cups tightly against the walls of the piston bore. The expanders prevent air from being

drawn past the cups and into the hydraulic system when the brakes are released.

Removal

(1) Remove wheels, brakedrums, and brakeshoes. Refer to Drum Brake Section for procedure.

(2) Disconnect brake line at wheel cylinder. Do not bend line away from cylinder. When cylinder is removed, line will separate from cylinder easily.

(3) Remove cylinder-to-support plate bolts and remove cylinder.

Overhaul

(1) Remove brakeshoe links and dust boots.

(2) Push pistons, piston cups, and compression spring and expanders out of piston bore. Discard piston cups, they are not reusable.

(3) Clean all cylinder components using brake cleaning solvent or brake fluid only.

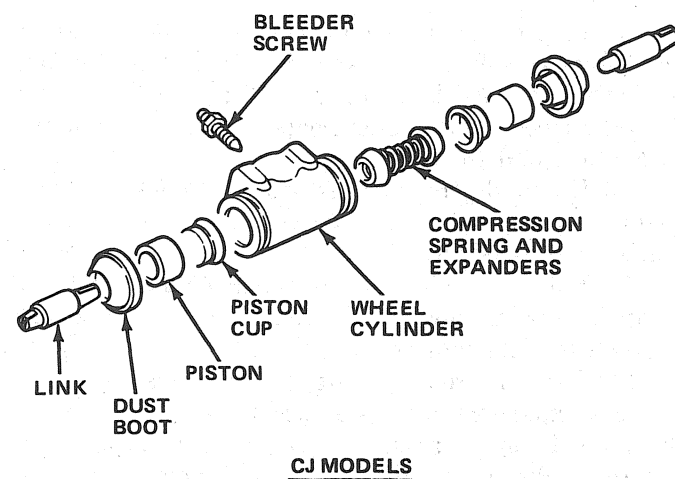

CJ MODELS

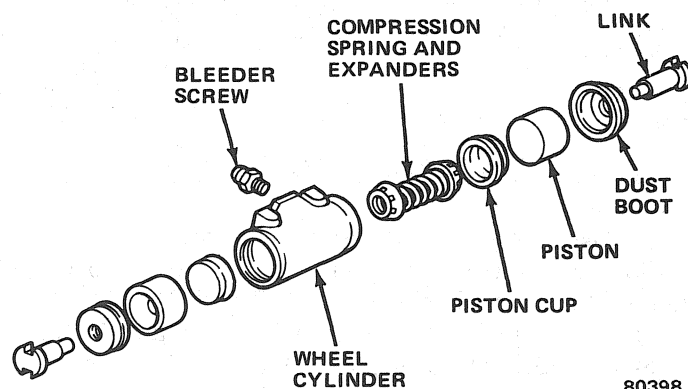

**CHEROKEE, WAGONEER
TRUCK MODELS**

80398

Fig. 2G-13 Wheel Cylinder

CAUTION: Do not clean brake parts with solvents containing mineral oil such as gasoline, carbon tetrachloride, kerosene, alcohol, paint thinner or similar fluids. Mineral oil causes swelling, deterioration, and premature aging of all rubber parts in the hydraulic system. Use clean brake fluid or an approved brake cleaning solvent only.

(4) Inspect wheel cylinder and pistons. Replace cylinder if bore or pistons are scored, corroded, rusted, pitted, worn, or cracked. If bore or pistons are only discolored, or stained, polish bore or pistons lightly using crocus cloth only. Do not polish cylinder bore in lengthwise direction, polish by rotating cylinder around crocus cloth supported on fingers.

CAUTION: Do not hone the wheel cylinders at any time or for any reason.

(5) Inspect bleeder screw and screw threads in cylinder. Screw must turn freely. Replace screw if damaged or replace cylinder if cylinder threads are damaged.

(6) Inspect compression spring and integral expanders. Replace spring if broken, distorted, lacks tension, or if expanders are damaged in any way.

(7) Inspect rubber dust boots. Replace boots if cut, torn, cracked, distorted.

(8) If cylinder bore or pistons were polished, clean them using brake fluid or brake cleaning solvent and dry using compressed air.

(9) Lubricate cylinder bore and all cylinder internal components with new brake fluid. Do not lubricate dust boots. Install them dry only.

(10) Position replacement piston cups on compression expanders and install assembled parts in cylinder bore. Be sure expanders are seated in piston cups and that cups are installed with lips facing one another and toward interior of cylinder bore.

(11) Install pistons in cylinder bore. Be sure pistons are installed with flat sides facing interior of bore.

(12) Install dust boots.

Installation

(1) Clean wheel cylinder mounting surface of support plate.

(2) Clean brake line fitting and threads.

(3) Start brake line fitting into cylinder. Do not tighten fitting completely.

(4) Position cylinder on support plate and install cylinder mounting bolts. Tighten bolts to 18 foot-pounds (24 N•m) torque.

(5) Insert brakeshoe connecting links through dust boots and into pistons.

(6) Install Wheel Cylinder Clamp Tool J-8002 over cylinder to retain internal components in cylinder.

(7) Tighten wheel cylinder brake line fitting.

COMBINATION VALVE

A three-function combination valve is used on all Jeep models. The valve consists of a one-piece housing containing a front brake metering valve, a pressure differential warning valve, and a rear brake proportioning valve. The combination valve also serves as the junction block for the front brakes.

Two different combination valves are used. Some models may be equipped with the type-W valve (fig. 2G-14), while other models may be equipped with the type-D valve (fig. 2G-15). Although the two valve types differ in external appearance and in internal component design, valve function and operation is the same for both.

Combination valve location is the same for all models. The valve is mounted on the inner side of the left frame rail adjacent to the transmission (fig. 2G-16).

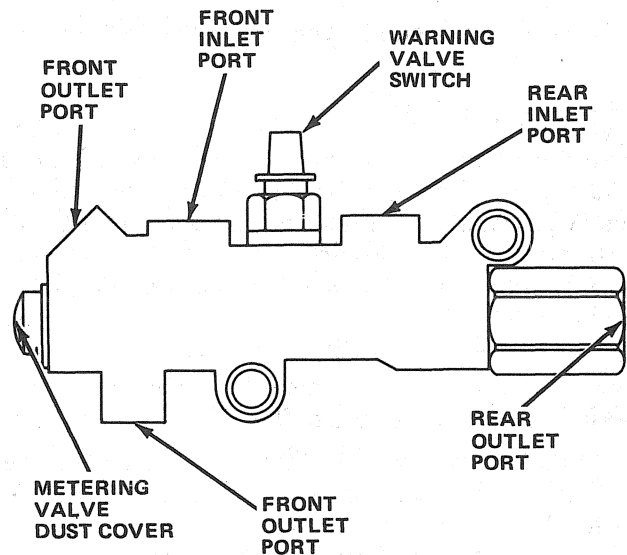

70569

Fig. 2G-14 Type-W Combination Valve

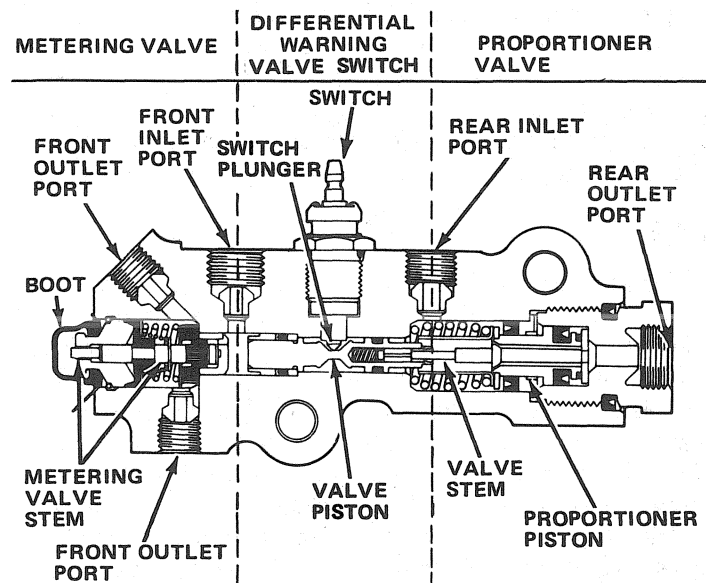

41120

Fig. 2G-15 Type-D Combination Valve

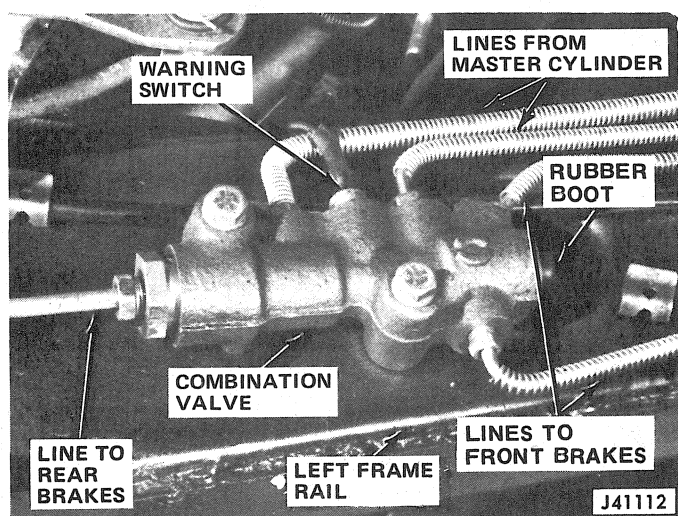

Fig. 2G-16 Combination Valve Location (Type-D Valve Shown)

Combination Valve Operation

The front brake metering valve assists in providing balanced front-to-rear braking. To accomplish this, the metering valve holds off (delays) full hydraulic fluid pressure to the front disc brakes until the rear drum brakes overcome return spring tension and the linings contact the drums.

When the brakes are not applied, the metering valve permits the free flow of brake fluid. This feature allows the fluid to expand and contract with changes in temperature.

When bleeding the front disc brakes, the metering valve stem must be held out using tool J-26869 on type-W valves or tool J-23709 on type-D valves. Refer to Brake Bleeding for specific details regarding tool use.

The pressure differential warning valve activates the brake warning lamp if a pressure loss in the front or rear hydraulic system should ever occur. This feature is provided as a method for alerting the driver if such a system malfunction ever occurs.

The valve consists of a valve piston, and plunger-type switch. If a pressure loss in either system occurs, a pressure differential of 70 to 300 psi (483 to 2 068 kPa) will cause the piston to shuttle toward the low pressure side of the valve. As the piston moves, ramps on the piston force the switch contact plunger upward closing the switch contacts. This action completes the electrical circuit between the switch and brake warning lamp causing the light to illuminate. Unless the lock cylinder is turned to the Off position, the warning light will remain illuminated until the cause of the malfunction is corrected and the valve recentered.

NOTE: The type D and W combination valves are hydraulic self-reset types which do not require manual recentering.

The rear brake proportioning valve provides balanced front-to-rear braking action during high pedal pressure stops. During light pedal pressure application, the proportioner does not operate. Brake fluid normally flows through the proportioner valve and into the rear brake wheel cylinders. Spring pressure on the valve piston holds it against the piston stop plate for normal brake pressures.

Combination Valve Service

The combination valve is not repairable. If any section of the valve is found defective, the entire valve assembly must be replaced.

BRAKE BLEEDING

General

The brake hydraulic system must be purged of air whenever a line has been disconnected or if air has entered the system.

In most cases, it will be necessary to bleed only that portion of the hydraulic system (front or rear) being serviced. However, if a firm brake pedal cannot be obtained, or if diagnosis indicates the need, the entire system must be bled.

Brake bleeding can be performed manually or with pressure equipment. Bleeder screws are provided at the calipers and wheel cylinders to simplify the bleeding procedure.

Manual Bleeding Procedure

- (1) Remove all accumulated dirt from master cylinder and cover.
- (2) Remove master cylinder cover.
- (3) Fill master cylinder if required and install cover.
- (4) On vehicles equipped with type-W combination valve, remove dust cover from metering valve stem and install tool J-26869 on stem to hold valve open (fig. 2G-17).
- (5) On vehicles equipped with type-D combination valve, loosen valve front mounting bolt and insert slotted end of tool J-23709 under bolt. Push metering valve stem inward (using tool) to hold valve open and tighten mounting bolt to secure tool (fig. 2G-18).

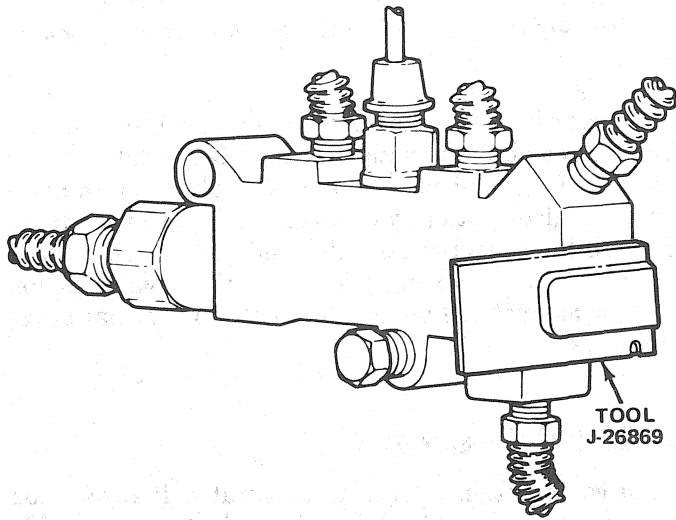

70570

Fig. 2G-17 Metering Valve Tool Installation
Type-W Combination Valve

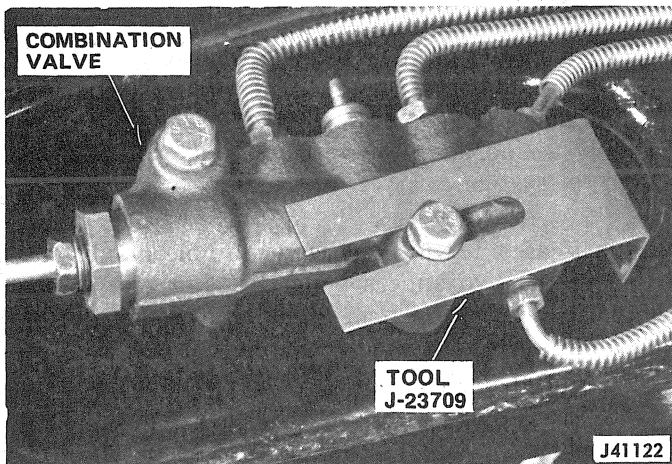

Fig. 2G-18 Metering Valve Tool Installation
Type-D Combination Valve

- (6) Bleed brake system in following sequence:
- (a) right rear wheel
 - (b) left rear wheel
 - (c) right front wheel
 - (d) left front wheel
 - (e) master cylinder brake line connections

NOTE: Correct bleeding procedure is as follows: Place wrench on bleeder screw. Install rubber hose on screw with free end of hose submerged in a transparent container partially filled with clean brake fluid. Open bleeder screw 3/4 turn. Have helper depress brake pedal. Close bleeder screw before pedal reaches end of travel. Have helper pump up pedal each time bleeder screw is closed to ensure a good surge of fluid when the screw is reopened. Repeat bleeding process until fluid comes out in a solid stream without the presence of air bubbles.

CAUTION: Do not allow the supply of fluid in the master cylinder to become exhausted. Check the fluid level frequently while bleeding and refill as required. Do not bleed two wheels at a time and do not bleed the system with the front calipers or rear drums not in place.

- (7) Remove master cylinder cover and refill as required. Fill reservoir to within 1/4 inch (6.35 mm) of reservoir rim. Install cover. Make sure cover retainer is in place.
- (8) Remove metering valve tool.
- (9) Test brake operation before moving vehicle.

Pressure Bleeding Procedure

- (1) Remove all accumulated dirt from master cylinder and cover.
- (2) Remove cover and rubber diaphragm seal. Place cover on work bench or on lint-free cloth. Do not allow diaphragm seal to contact dirt or foreign material.
- (3) Fill master cylinder if required.
- (4) Install brake bleeder adapter cover on master cylinder (figs. 2G-19 and 2G-20).

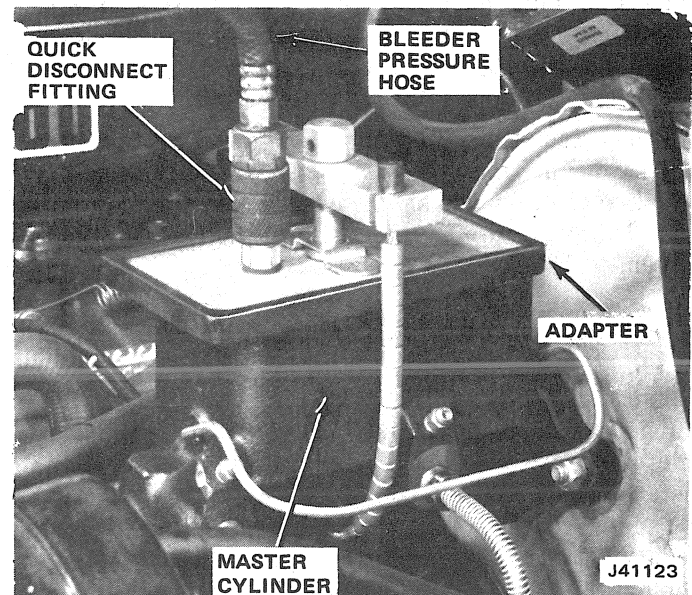
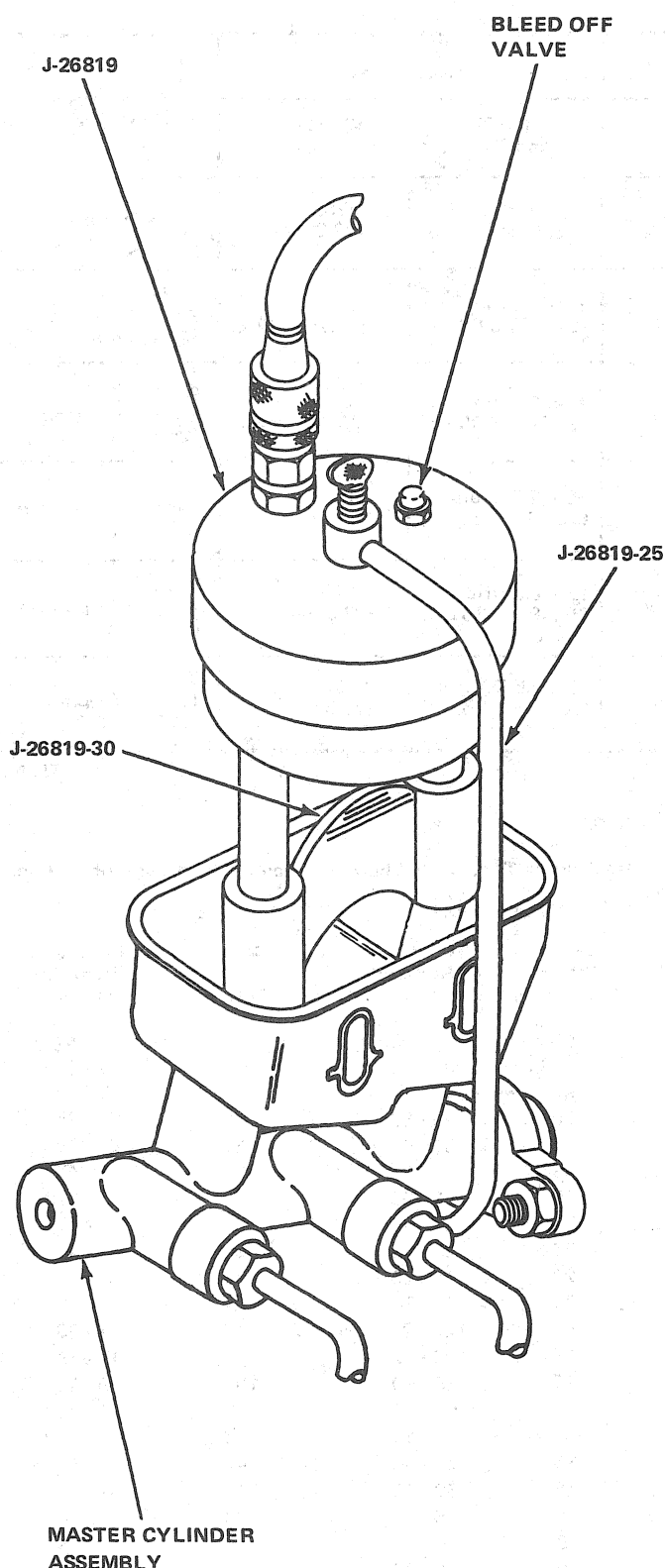

Fig. 2G-19 Pressure Bleeder Adapter Installation—Typical



(5) Connect hose from pressure bleeder to fitting on adapter and open pressure bleeder release valve.

(6) On vehicles with type-W combination valve, remove dust cover from metering valve stem and install tool J-26869 on stem to hold valve open (fig. 2G-17).

(7) On vehicles equipped with type-D combination valve, loosen valve front mounting bolt and insert slotted end of tool J-23709 under bolt. Push metering valve stem inward (using tool) to hold valve open and tighten mounting bolt to secure tool (fig. 2G-18).

(8) Bleed brake system in following sequence:

- (a) right rear wheel
- (b) left rear wheel
- (c) right front wheel
- (d) left front wheel
- (e) master cylinder brake line connections

NOTE: When using pressure equipment, the bleeding procedure is the same as outlined in the Manual Bleeding Procedure except that a helper is not required to apply the brake pedal. The pressure bleeder develops enough system pressure to permit bleeding without the use of the brake pedal.

(9) When system has been purged of all air, turn off pressure bleeder and close bleeder fluid release valve.

(10) Disconnect pressure bleeder hose at adapter fitting and remove master cylinder cover adapter.

(11) Refill master cylinder reservoirs to within 1/4 inch (6.35 mm) of reservoir rims.

(12) Install cover and rubber diaphragm seal. Make sure cover retainer is in place.

(13) On vehicles equipped with type-W combination valve, remove tool J-26869 from metering valve stem and install dust cover. On vehicles equipped with type-D combination valve, loosen valve front mounting bolt, remove tool J-23709, and retighten mounting bolt.

(14) Test brake operation before moving vehicle.

SPECIFICATIONS

General Specifications

Brake Fluid	Use Jeep brake fluid or equivalent marked DOT 3 or SAE-J-1703 only.
Brake Fluid Level	Fill master cylinder reservoirs to within 1/4 inch (6.35 mm) of reservoir rims.

81099A

Fig. 2G-20 Pressure Bleeder Adapter Installation—
Cherokee-Wagoneer-Truck Models

Brake Size and Application Chart

Model	Master Cylinder Bore Diameter	Front Brakes		Rear Brakes		Power Brake Unit Type
		Brake Size And Type	Caliper Piston Diameter	Brake Size And Type	Wheel Cyl. Diameter	
CJ	1.00 (25.4 mm)	11.7 Disc. (29.7 cm)	2.6 Single Piston (6.60 cm)	10 x 1.75 Drum (25.4 x 4.44 cm)	.875 (22.2 mm)	8.00 Single Diaphragm (20.3 cm)
Cherokee Wagoneer	1.125 (28.5 mm)	12.0 Disc. (30.48 cm)	2.937 Single Piston (7.45 cm)	11 x 2 Drum (27.94 x 5.08 cm)	.937 (23.79 mm)	9 1/2 Single Diaphragm (24.13 cm)
J-10 Truck	1.125 (28.5 mm)	12.0 Disc. (30.48 cm)	2.937 Single Piston (7.45 cm)	11 x 2 Drum (27.94 x 5.08 cm)	.937 (23.79 mm)	9 1/2 Single Diaphragm (24.13 cm)
J-20 Truck 6800 GVW	1.125 (28.5 mm)	12.5 Disc. (31.75 cm)	2.937 Single Piston (7.45 cm)	12 x 2.5 Drum (30.48 x 6.35 cm)	1.125 (28.5 mm)	9 1/2 Tandem Diaphragm (24.13 cm)
J-20 Truck 7600 GVW	1.125 (28.5 mm)	12.5 Disc. (31.75 cm)	2.937 Single Piston (7.45 cm)	12 x 2.5 Drum (30.48 x 6.35 cm)	1.125 (28.5 mm)	9 1/2 Tandem Diaphragm (24.13 cm)
J-20 Truck 8400 GVW	1.125 (28.5 mm)	12.5 Disc. (31.75 cm)	2.937 Single Piston (7.45 cm)	12 x 2.5 Drum (30.48 x 6.35 cm)	1.125 (28.5 mm)	9 1/2 Tandem Diaphragm (24.13 cm)

41102

Torque Specifications

Service Set-To Torques should be used when assembling components. Service In-Use Recheck Torques should be used for checking a pre-torqued item.

	USA (ft -lbs)		Metric (N-m)	
	Service Set - to Torque	In - Use Recheck Torque	Service Set - to Torque	In - Use Recheck Torque
Brakeline-to-Caliper Fitting Bolt (Cke, Wag, Trk)	160 in-lbs.	120 - 200 in-lbs.	18	14 - 23
Bleeder Screw (1/4 - 28)	45 in-lbs.	40 - 50 in-lbs.	5	5 - 6
Bleeder Screw (3/8 - 24)	90 in-lbs.	40 - 140 in-lbs.	10	5 - 16
Brake Support Plate Mounting Bolts/Nuts (J-20 Trk)	50	45 - 55	68	61 - 75
Brake Support Plate Mounting Bolts/Nuts (Cke, Wag, J10 Trk)	45	35 - 55	61	47 - 75
Brake Support Plate Mounting Bolts/Nuts (CJ)	33	30 - 35	45	41 - 47
Caliper Anchor Bracket to Steering Knuckle (CJ)	85	75 - 95	115	102 - 129
Master Cylinder Mounting Bolts/Nuts	30	25 - 35	41	34 - 47
Master Cylinder-to-Power Unit Mounting Nuts	25	20 - 30	34	27 - 41
Power Brake Unit-to-Dash Mounting Bolts/Nuts	22	18 - 25	30	24 - 34
Brake Line-to-Caliper Fitting Bolt (CJ)	25	20 - 30	34	27 - 41
Brake Line-to-Wheel Cylinder Fitting	160 in-lbs.	120 - 200 in-lbs.	18	14 - 23
Parking Brake Cable Clamp-to-Support Plate Bolts (5/16 - 18)	10	8 - 12	14	11 - 16
Wheel Nuts (CJ)	75	65 - 90	102	88 - 122
Wheel Nuts (Cke, Wag, Trk)	75	65 - 80	102	88 - 108
Wheel Nuts (8400 GVW Trk)	130	110 - 150	176	149 - 203
Brake Pedal-to-Power Unit Push Rod Bolt/Nut	35	25 - 40	47	34 - 54
Caliper Mounting Bolts (Cke, Wag, Trk)	35	30 - 40	47	41 - 54
Caliper Support Key Retaining Screw (CJ)	15	15 - 18	20	20 - 24
Disc. Brake Shield Bolts (Cke, Wag, Trk)	8	5 - 10	11	7 - 14
Disc. Brake Shield Nuts (Cke, Wag, Trk)	35	30 - 40	47	41 - 54
Wheel Bearing Outer Locknut (All)	50(min.)		68 (min.)	
Wheel Bearing Inner Locknut (Bearing Adjuster):				
CJ	Tighten to 50 ft-lbs. (68 N-m) and back off 1/6 turn while rotating wheel.			
Cke, Wag, Trk	Tighten to 50 ft-lbs. (68 N-m) and back off 1/6 turn while rotating wheel.			

All Torque values given in foot-pounds and newton-meters with dry fits unless otherwise specified.

60647

POWER BRAKE UNITS

	Page		Page
General	2G-31	Power Unit Removal	2G-33
Power Unit Diagnosis	2G-33	Power Unit Service	2G-33
Power Unit Installation	2G-33	Specifications	2G-33

GENERAL

Three power units are used on Jeep vehicles. An 8-inch single diaphragm unit is used on CJ models (fig. 2G-21). A 9-1/2 single diaphragm unit is used on Cherokee, Wagoneer and J-10 Truck models (fig. 2G-22) and a 9-1/2 tandem diaphragm unit is used on J-20 Truck models.



Fig. 2G-21 Power Brake Unit and Bellcrank—CJ Models

The power units consist of a two-piece outer shell containing the single or dual diaphragms, air inlet valve, air filter, control valve, power piston, reaction plate and master cylinder push rod, and vacuum check valve (figs. 2G-23 and 2G-24).

Power Unit Operation

The power unit utilizes a combination of engine vacuum and atmospheric pressure to increase brake apply force without increasing brake pedal efforts.

In the neutral (nonapplied) position, a vacuum is present within the chamber formed by the two halves of the outer shell and on both sides of the power piston and diaphragm.

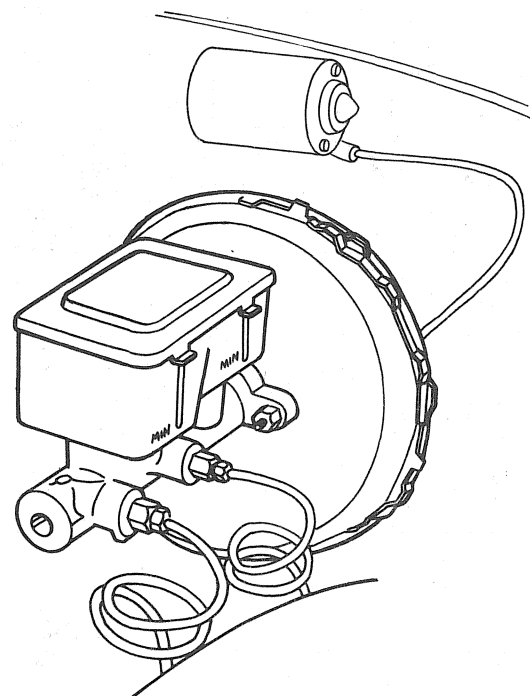

60645

**Fig. 2G-22 Power Brake Unit
Cherokee-Wagoneer-Truck Models**

As the brake pedal is pressed, the brake pedal push rod moves the air inlet valve away from the control valve (figs. 2G-23 and 2G-24). The control valve then follows the air inlet valve until the control valve contacts the raised seat on the power piston. When contact occurs, vacuum to the chamber space at the right side of the power piston is shut off.

At vacuum shut off, air under an atmospheric pressure of 14.7 psi (101.3 kPa), then flows into the right side of the chamber through the air filter. Since a vacuum still exists in the left side of the chamber, the force of air at atmospheric pressure on the right side of the power piston forces the piston and master cylinder push rod to the left applying the brakes.

When the brake pedal is released, the control valve returns to its seat against the air inlet valve shutting off the supply of air under atmospheric pressure. At this point, engine vacuum coming through the vacuum check valve again enters the right side of the chamber past the power piston.

In operation, the single and tandem diaphragm units function in exactly the same manner with one exception.

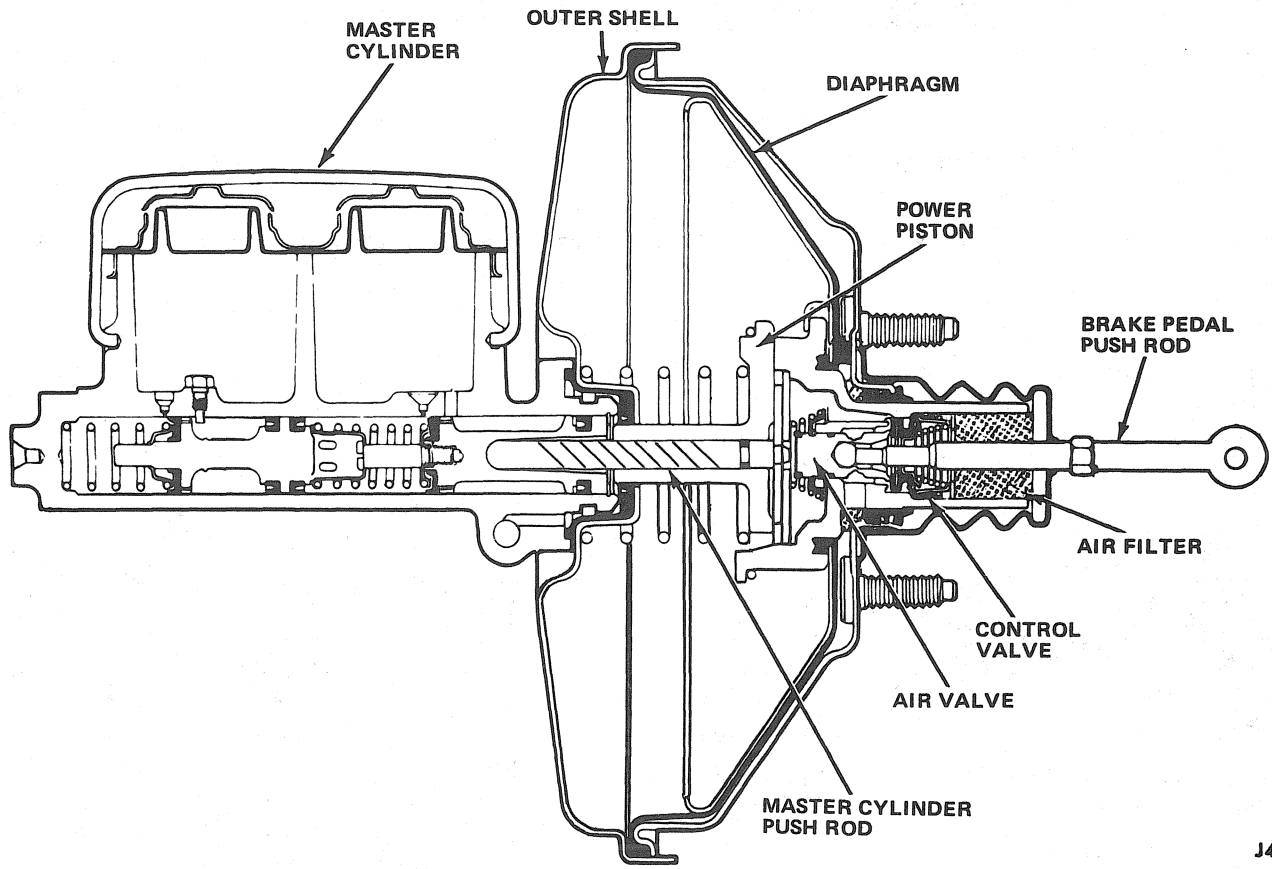

J41110

Fig. 2G-23 Single Diaphragm Power Unit—Typical

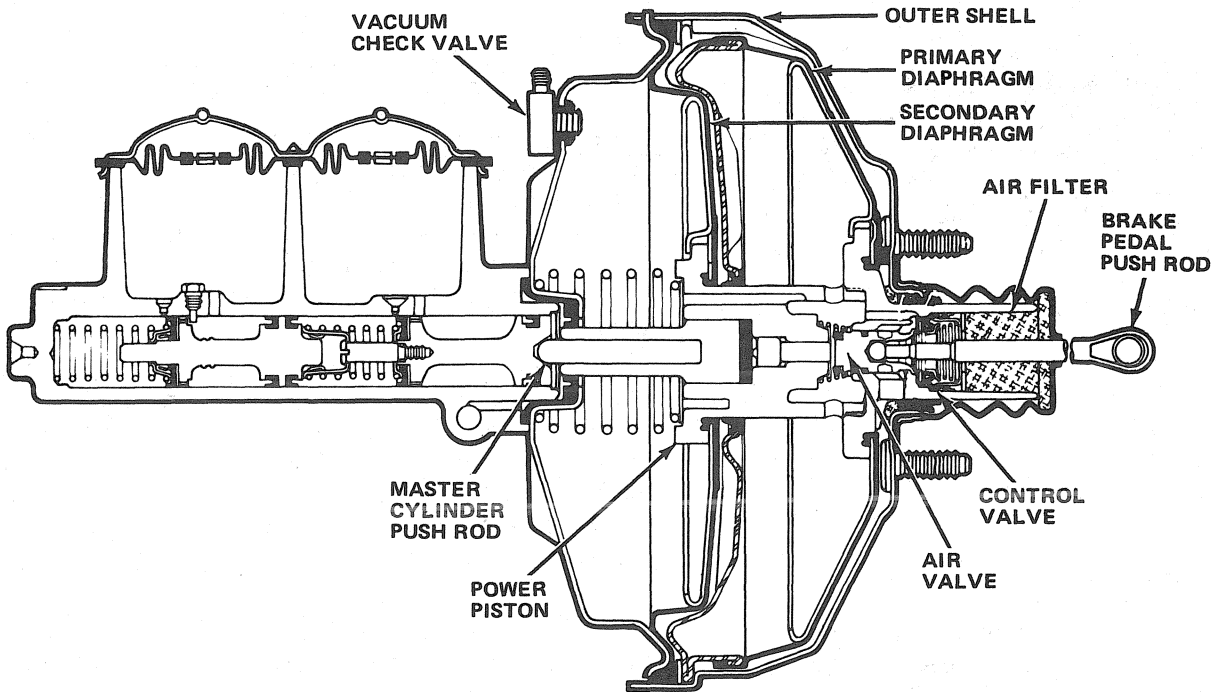

80383

Fig. 2G-24 Tandem Diaphragm Power Unit—Typical

The tandem unit utilizes two chambers on the right side of the power piston to develop atmospheric air pressure on the power piston.

POWER UNIT SERVICE

All power units are serviced as assemblies only. If diagnosis indicates that an internal malfunction has occurred within a power unit, replace the unit as an assembly. Do not attempt to repair the unit.

All power units have a single master cylinder push rod of a preset, nonadjustable length. When replacing a power unit, use the push rod supplied with the replacement power unit only. This push rod has been correctly gauged to the replacement unit.

POWER UNIT DIAGNOSIS

Power unit malfunction should be diagnosed using Brake Diagnosis Guide B and the Power Unit and Service Diagnosis Charts. When diagnosing suspected power unit malfunctions, always perform the preliminary diagnosis procedures outlined in Brake Diagnosis Guide A first. This is an important step in avoiding inaccurate diagnosis and ineffective repair.

POWER UNIT REMOVAL

- (1) Disconnect power unit push rod at brake pedal. Discard bolt and nut attaching rod to pedal.
- (2) Disconnect vacuum at power unit check valve.
- (3) Remove nuts and washers attaching master cylinder to power unit and move master cylinder aside. Do not disconnect brake lines at master cylinder.

(4) On CJ models, remove nuts and bolts attaching power unit bellcrank to dash panel and remove power unit and bellcrank as assembly.

(5) On Cherokee, Wagoneer and Truck models, remove nuts and washers attaching power unit to dash panel and remove power unit.

NOTE: *If the power unit is to be replaced on CJ models, remove the bellcrank from the original power unit, lubricate the bellcrank pivot pins with chassis lubricant, and transfer the bellcrank to the replacement unit.*

POWER UNIT INSTALLATION

(1) On Cherokee, Wagoneer and Truck models, mount power unit on dash panel and install attaching washers and nuts. Tighten nuts to 35 foot-pounds (47 N•m) torque.

(2) On CJ models, mount assembled power unit and bellcrank on dash panel. Install bellcrank-to-dash panel attaching bolts and nuts. Tighten bolts to 35 foot-pounds (47 N•m) torque.

(3) Connect vacuum hose to power unit check valve.

(4) Position master cylinder on power unit and install cylinder attaching washers and nuts. Tighten nuts to 30 foot-pounds (41 N•m) torque.

(5) Align power unit push rod and brake pedal and install replacement pedal attaching bolt and nut. Tighten bolt and nut to 35 foot-pounds (47 N•m) torque.

SPECIFICATIONS

Brake Size and Application Chart

Model	Master Cylinder Bore Diameter	Front Brakes		Rear Brakes		Power Brake Unit Type
		Brake Size And Type	Caliper Piston Diameter	Brake Size And Type	Wheel Cyl. Diameter	
CJ	1.00 (25.4 mm)	11.7 Disc. (29.7 cm)	2.6 Single Piston (6.60 cm)	10 x 1.75 Drum (25.4 x 4.44 cm)	.875 (22.2 mm)	8.00 Single Diaphragm (20.3 cm)
Cherokee Wagoneer	1.125 (28.5 mm)	12.0 Disc. (30.48 cm)	2.937 Single Piston (7.45 cm)	11 x 2 Drum (27.94 x 5.08 cm)	.937 (23.79 mm)	9 1/2 Single Diaphragm (24.13 cm)
J-10 Truck	1.125 (28.5 mm)	12.0 Disc. (30.48 cm)	2.937 Single Piston (7.45 cm)	11 x 2 Drum (27.94 x 5.08 cm)	.937 (23.79 mm)	9 1/2 Single Diaphragm (24.13 cm)
J-20 Truck 6800 GVW	1.125 (28.5 mm)	12.5 Disc. (31.75 cm)	2.937 Single Piston (7.45 cm)	12 x 2.5 Drum (30.48 x 6.35 cm)	1.125 (28.5 mm)	9 1/2 Tandem Diaphragm (24.13 cm)
J-20 Truck 7600 GVW	1.125 (28.5 mm)	12.5 Disc. (31.75 cm)	2.937 Single Piston (7.45 cm)	12 x 2.5 Drum (30.48 x 6.35 cm)	1.125 (28.5 mm)	9 1/2 Tandem Diaphragm (24.13 cm)
J-20 Truck 8400 GVW	1.125 (28.5 mm)	12.5 Disc. (31.75 cm)	2.937 Single Piston (7.45 cm)	12 x 2.5 Drum (30.48 x 6.35 cm)	1.125 (28.5 mm)	9 1/2 Tandem Diaphragm (24.13 cm)

Torque Specifications

Service Set-To Torques should be used when assembling components. Service In-Use Recheck Torques should be used for checking a pre-torqued item.

	USA (ft -lbs)		Metric (N-m)	
	Service Set - to Torque	In - Use Recheck Torque	Service Set - to Torque	In - Use Recheck Torque
Brakeline-to-Caliper Fitting Bolt (Cke, Wag, Trk)	160 in-lbs.	120 - 200 in-lbs.	18	14 - 23
Bleeder Screw (1/4 - 28)	45 in-lbs.	40 - 50 in-lbs.	5	5 - 6
Bleeder Screw (3/8 - 24)	90 in-lbs.	40 - 140 in-lbs.	10	5 - 16
Brake Support Plate Mounting Bolts/Nuts (J-20 Trk)	50	45 - 55	68	61 - 75
Brake Support Plate Mounting Bolts/Nuts (Cke, Wag, J10 Trk)	45	35 - 55	61	47 - 75
Brake Support Plate Mounting Bolts/Nuts (CJ)	33	30 - 35	45	41 - 47
Caliper Anchor Bracket to Steering Knuckle (CJ)	85	75 - 95	115	102 - 129
Master Cylinder Mounting Bolts/Nuts	30	25 - 35	41	34 - 47
Master Cylinder-to-Power Unit Mounting Nuts	25	20 - 30	34	27 - 41
Power Brake Unit-to-Dash Mounting Bolts/Nuts	22	18 - 25	30	24 - 34
Brake Line-to-Caliper Fitting Bolt (CJ)	25	20 - 30	34	27 - 41
Brake Line-to-Wheel Cylinder Fitting	160 in-lbs.	120 - 200 in-lbs.	18	14 - 23
Parking Brake Cable Clamp-to-Support Plate Bolts (5/16 - 18)	10	8 - 12	14	11 - 16
Wheel Nuts (CJ)	75	65 - 90	102	88 - 122
Wheel Nuts (Cke, Wag, Trk)	75	65 - 80	102	88 - 108
Wheel Nuts (8400 GVW Trk)	130	110 - 150	176	149 - 203
Brake Pedal-to-Power Unit Push Rod Bolt/Nut	35	25 - 40	47	34 - 54
Caliper Mounting Bolts (Cke, Wag, Trk)	35	30 - 40	47	41 - 54
Caliper Support Key Retaining Screw (CJ)	15	15 - 18	20	20 - 24
Disc. Brake Shield Bolts (Cke, Wag, Trk)	8	5 - 10	11	7 - 14
Disc. Brake Shield Nuts (Cke, Wag, Trk)	35	30 - 40	47	41 - 54
Wheel Bearing Outer Locknut (All)	50(min.)		68 (min.)	
Wheel Bearing Inner Locknut (Bearing Adjuster):				
CJ	Tighten to 50 ft-lbs. (68 N-m) and back off 1/6 turn while rotating wheel.			
Cke, Wag, Trk	Tighten to 50 ft-lbs. (68 N-m) and back off 1/6 turn while rotating wheel.			

All Torque values given in foot-pounds and newton-meters with dry fits unless otherwise specified.

60647

DRUM BRAKES

	Page		Page
Brakedrum Service	2G-39	General	2G-34
Brake Service—Cherokee-Wagoneer-Truck Models	2G-38	Operation and Wear Compensation	2G-34
Brake Service—CJ Models	2G-36	Specifications	2G-40

GENERAL

Two different drum brake units are used on Jeep vehicles. The brakes used on CJ models have a cable operated automatic adjuster mechanism, while the brakes used on Cherokee, Wagoneer and Truck models have a linkage operated automatic adjuster mechanism. Although the units differ slightly in construction, operation and service procedures for both units are similar.

Each drum brake unit consists of a support plate, a primary and a secondary brakeshoe, two brakeshoe return springs, an adjusting screw assembly, two hold-down springs, automatic adjuster components, and a wheel cylinder assembly (figs. 2G-25 and 2G-26).

OPERATION AND WEAR COMPENSATION

Operation

When the brakes are applied, fluid pressure developed in the master cylinder is transmitted to the wheel cylinders forcing the cylinder pistons outward. This motion is transferred to the upper ends of the brakeshoes through links which interconnect the brakeshoes and wheel cylinder pistons.

As the brakeshoes are expanded and contact the drum, they tend to rotate with the drum. This action causes the primary brakeshoe to pivot downward and away from the support plate anchor pin and the secondary brakeshoe to pivot upward and against the anchor pin.

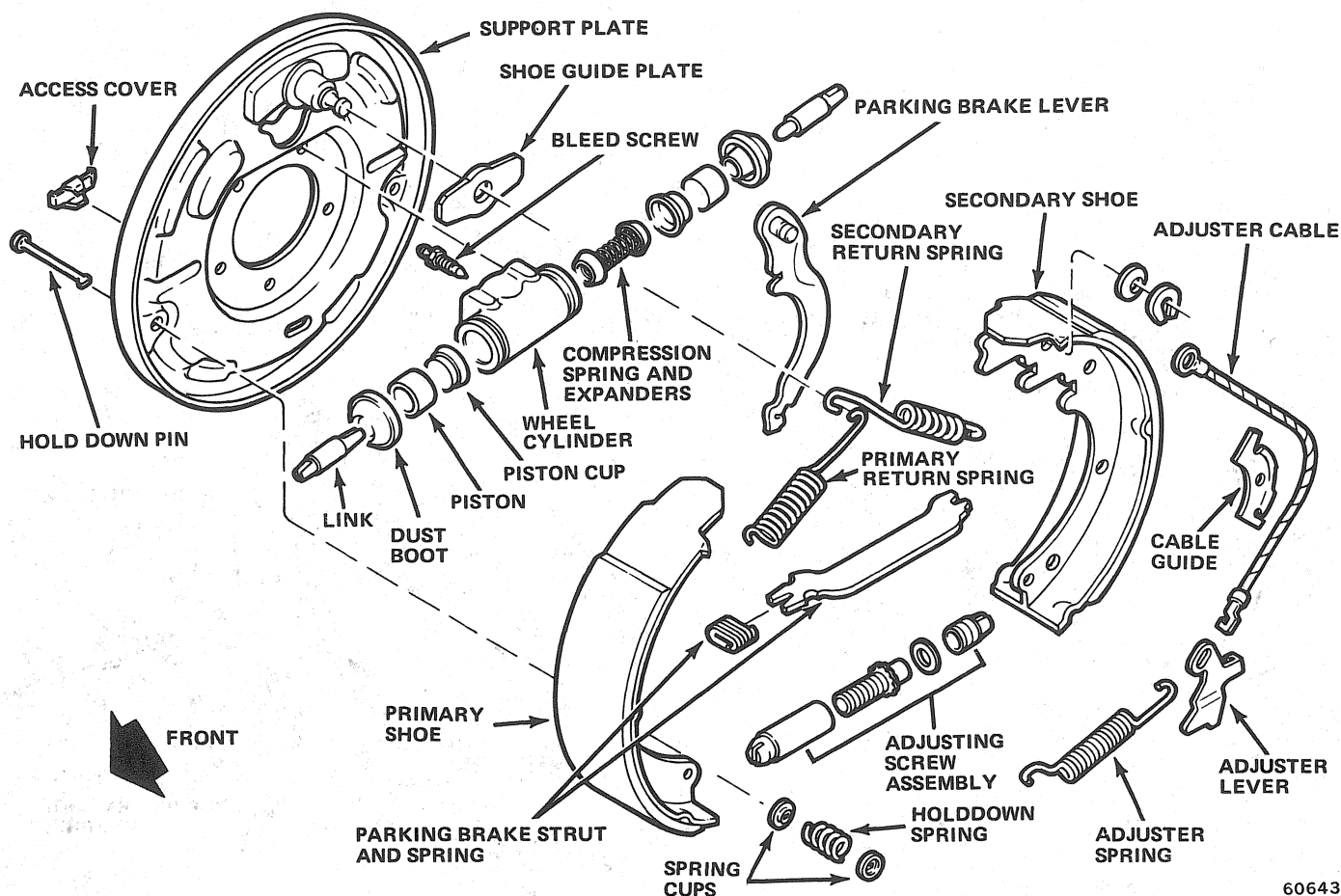

60643

Fig. 2G-25 Drum Brake Assembly—CJ Models

As the primary brakeshoe pivots downward, it exerts a rearward force on the adjuster screw assembly. Since the adjuster screw interconnects the lower ends of the brakeshoes, this additional force is transmitted directly to the secondary brakeshoe increasing its braking action. The additional force applied to the secondary brakeshoe accounts for the fact that the secondary brakeshoe linings are generally thicker and have more contact area.

When the brakes are released, the return springs overcome the diminishing fluid pressure and return the brakeshoes and wheel cylinder pistons to the neutral position.

During a reverse stop, the drum brakes operate in the same mode as for a forward stop. However, because the drum is rotating in the opposite direction, the secondary brakeshoe now operates, in effect, as the primary brakeshoe.

Parking Brake Operation

The parking brake lever is mounted on the back of the brakeshoe and is connected to it by a pivot pin

installed in the upper end of the lever. The pin is retained in the brakeshoe by a washer and U-clip. The parking brake cable is attached to the lower end of the lever. A strut, located just below the pivot pin, connects the lever to the primary brakeshoe. The strut is notched at each end and fits into matching notches in the brakeshoe and lever. The strut is positioned in the brakeshoe by an oval shaped spring.

When the parking brakes are applied, the cable pulls the lower end of the lever forward causing the connecting strut to push the primary brakeshoe forward also. At the same time, the upper end of the lever pushes the secondary brakeshoe rearward. The combined action of lever and strut expands the brakeshoes forcing them against the drum to develop braking action.

Wear Compensation

The automatic adjuster mechanism continuously maintains correct lining-to-drum operating clearance by adjusting the brakes in small increments in direct proportion to lining wear. This continuous adjustment prevents a gradual increase in brake pedal travel as the linings wear. The adjuster mechanism also adds the

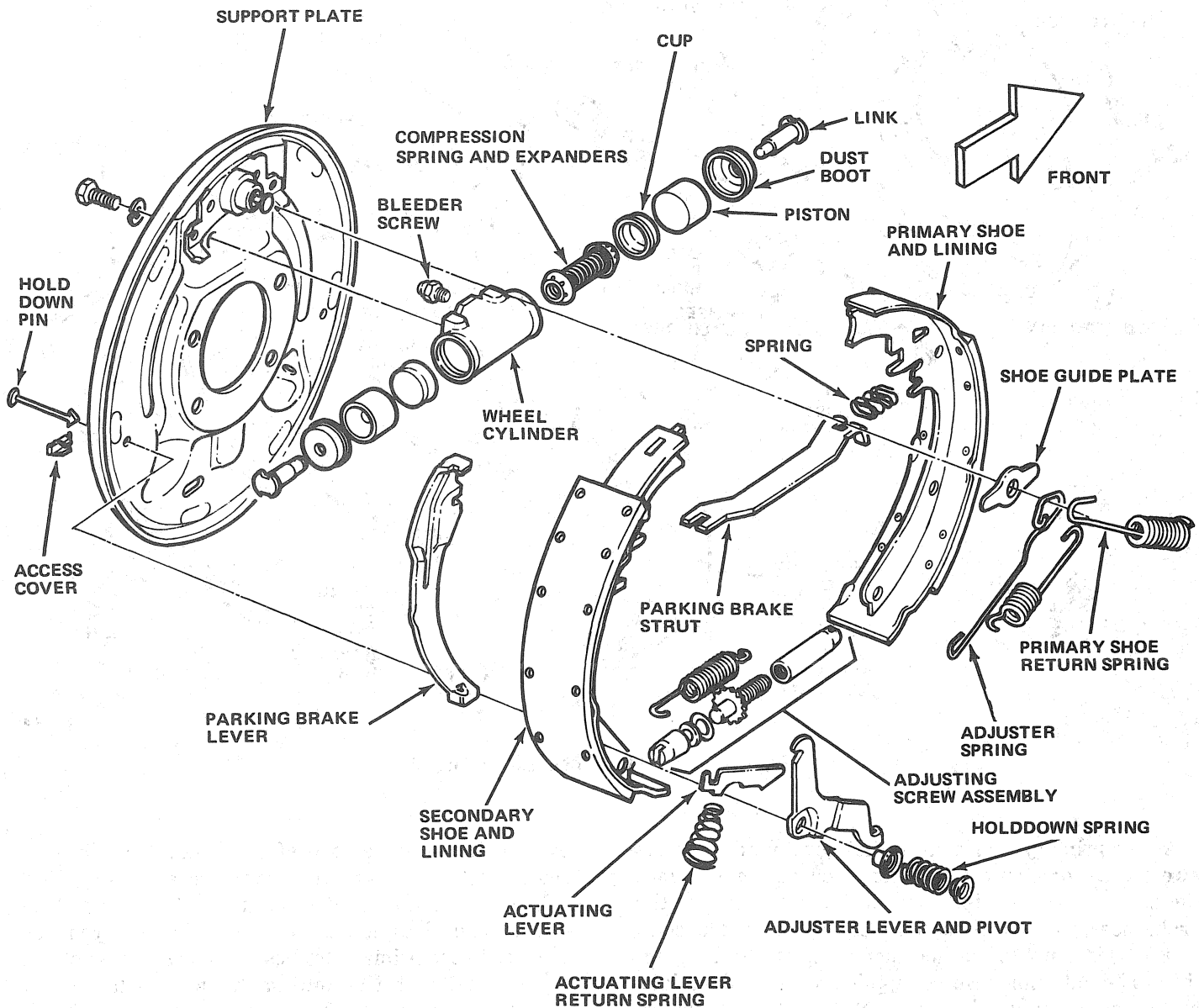

60241

Fig. 2G-26 Drum Brake Assembly—Cherokee-Wagoneer-Truck Models

safety feature of maintaining adequate pedal reserve during the service life of the lining.

When the lining wears enough to require adjustment, the adjusting cable (CJ) or actuating lever (Cherokee, Wagoneer and Truck) lifts the lever into engagement with the next tooth of the adjusting screw during reverse brake applications. When the brakes are released, the brakeshoes return to the anchor pin.

The adjuster mechanism utilizes movement of the secondary shoes during reverse brake applications to actuate the adjuster mechanism.

This action will repeat on subsequent brake applications until the drum-to-lining clearance is reduced to a point where shoe movement is no longer sufficient to

cause the adjuster mechanism to lift the lever to the next adjuster screw tooth.

BRAKE SERVICE—CJ MODELS

Disassembly

WARNING: When servicing wheel brake parts, do not create dust by grinding or sanding brakelinings or by cleaning wheel brake parts with a dry brush or with compressed air. Use water dampened cloths only to remove dirt from brake parts prior to disassembly. Many wheel brake parts contain asbestos fibers which can

become airborne if dust is created during servicing. Breathing dust containing asbestos fibers may cause serious bodily injury.

- (1) Raise vehicle.
- (2) Remove wheels and drums.
- (3) Grasp adjusting lever with pliers and remove lever tang from hole in secondary shoe.
- (4) Place Brake Cylinder Clamps J-8002 over wheel cylinders to hold pistons in place while shoes are removed.
- (5) Remove return springs using Brake Spring Remover Tool J-8057.
- (6) Remove secondary return spring, adjuster cable, primary return spring, cable guide, adjuster lever, and adjuster springs.
- (7) Remove holddown springs and brakeshoes.
- (8) Disengage parking brake cable from parking brake lever.

Cleaning and Inspection

Clean all parts, except the brakeshoes and brake drums, with brake cleaning solvent only. Clean brake drums with a soap and water solution only and replace brakeshoes that are contaminated with grease or brake fluid. Remove dirt and dust from the support plate using water dampened shop cloths only.

Pull the wheel cylinder dust boots aside and check for evidence of leakage. If leakage is observed, overhaul the wheel cylinders.

Polish the brake support plate ledges with fine sandpaper or emery cloth. If grooves, which may restrict shoe movement, still exist after polishing, replace the support plate. Do not attempt to remove grooves by grinding the ledges smooth as this could result in improper shoe-to-drum contact.

Inspect the lining wear pattern. If the wear across the width of the lining is uneven, check the drums for a bell-mouthed condition, inspect the drums for correct positioning, and inspect the support plate for distortion. Inspect all springs for evidence of overheating (discoloration), fractures, or distortion.

On CJ models, inspect the adjuster cable for kinks, fraying, or for an elongated (worn) eyelet. On all other models, inspect the adjuster levers for wear, cracks, or distortion.

Inspect the adjusting screw for freedom of rotation and the adjuster lever for wear and distortion.

Inspect the brake lines for evidence of leakage, swelling, distortion, kinks, or cracks.

Clean the support plates using compressed air or dry cloths and polish the anchor pins with crocus cloth. Also check the pins for being loose, worn, or damaged. Inspect the support plates for distortion or cracks and check the support plate-to-axle flange bolt torques.

Clean the brakedrums with a soap and water solution only. Inspect the drums for excessive wear, scoring, runout, cracks, heat checks, hard spots, or distortion.

Mount the drums on a brake lathe and check runout using a dial indicator. Radial runout must not exceed 0.005 inch. If runout exceeds this figure, replace or turn the drum. If the drums are machined, do not remove more than 0.030 inch (0.76 mm) total. Maximum allowable oversize for any drum is 0.060 inch (1.52 mm) over the original diameter. In addition, do not attempt to refinish drums with hard spots. Replace drums with this condition.

Assembly and Adjustment

NOTE: When it is necessary to replace the brakeshoes on one wheel, the brakeshoes must also be replaced on the opposite wheel to maintain braking balance.

- (1) Lubricate support plate ledges, anchor pin, self-adjuster cable guide, adjuster screw threads and pivot, and parking brake cable lever and pivot with molydisulphide grease or chassis lubricant.
- (2) Install parking brake lever on secondary brake-shoe and install washer and replacement lever retaining U-clip. Crimp ends of clip using pliers to retain it on pivot.
- (3) Position brakeshoes on brake support plate and install holddown springs (figs. 2G-25 and 2G-26).
- (4) Install parking brake cable in lever and install parking brake strut and positioning spring.
- (5) Place adjuster cable eyelet on anchor pin.
- (6) Install primary return spring (fig. 2G-27).

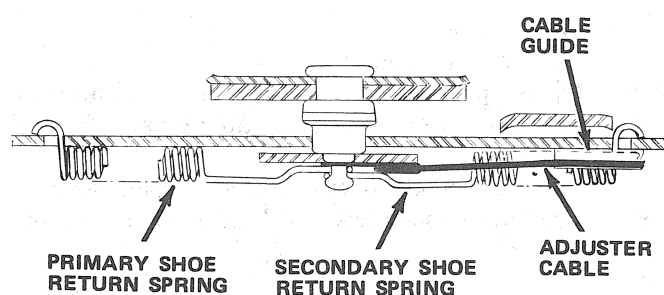

Fig. 2G-27 Return Spring Installation

- (7) Install cable guide on secondary brakeshoe.
- (8) Install secondary return spring (fig. 2G-27).
- (9) Install adjusting screw and spring on brakeshoes. Insert small hooked end of spring in large hole in primary brakeshoe and large hooked end of spring in adjuster lever.
- (10) Position adjuster cable in cable guide groove insert hooked end of cable in adjuster lever.
- (11) Grip adjuster lever with pliers and hook lever tang in large hole at bottom of secondary brakeshoe.

(12) Perform initial brake adjustment using clearance gauge or manual adjustment procedure. Refer to Service Brake Adjustment.

(13) Install brakedrums.

(14) If any brake lines were disconnected, bleed brakes. Refer to Brake Bleeding.

(15) Install rear wheels and tires.

(16) Lower vehicle.

(17) Check brake operation before moving vehicle.

(18) Drive vehicle in reverse and make 10 to 15 firm brake applications to complete brake adjustment. Make one forward brake application after each reverse application to equalize adjustment.

NOTE: If the vehicle has an automatic transmission, do not use the forward range to halt vehicle movement in reverse. This procedure will prevent the automatic adjuster mechanism from operating properly resulting in unsatisfactory pedal heights. All stops must be completed.

BRAKE SERVICE—CHEROKEE-WAGONEER-TRUCK MODELS

WARNING: When servicing wheel brake units, do not create dust by grinding or sanding brakelinings or by cleaning wheel brake parts with a dry brush or with compressed air. Use water dampened cloths only to remove dirt and dust from brake parts prior to disassembly. Many wheel brake parts contain asbestos fibers which can become airborne if dust is created during servicing operations. Breathing dust containing asbestos fibers may cause serious bodily harm.

Disassembly

(1) Raise vehicle.

(2) Remove rear wheels and drums.

(3) Release parking brake and loosen locknuts at parking brake equalizer to relieve cable tension before removing rear drums.

(4) On Truck models with Model 60 full-floating rear axle, remove two screws that locate rear drums on hubs (fig. 2G-28).

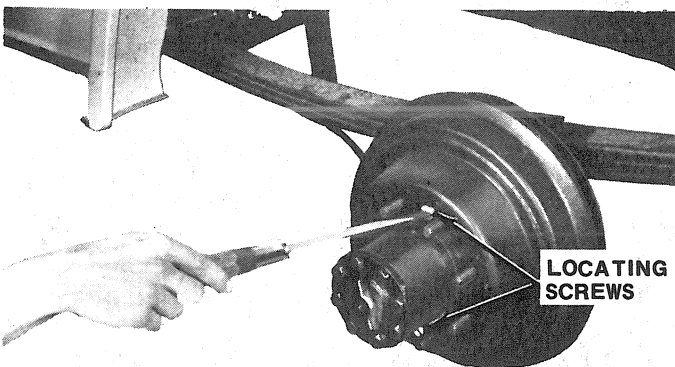

Fig. 2G-28 Brakedrum Locating Screw Removal—Model 60 Axle

(5) Remove primary brakeshoe return spring (fig. 2G-26).

(6) Remove automatic adjuster actuating spring and secondary brakeshoe return spring using Spring Remover Tool J-8057.

(7) Remove holddown springs and remove brakeshoes.

(8) Disengage parking brake cable from parking brake lever on secondary brakeshoe.

(9) Place Wheel Cylinder Clamps J-8002 over wheel cylinders to retain pistons (fig. 2G-29).

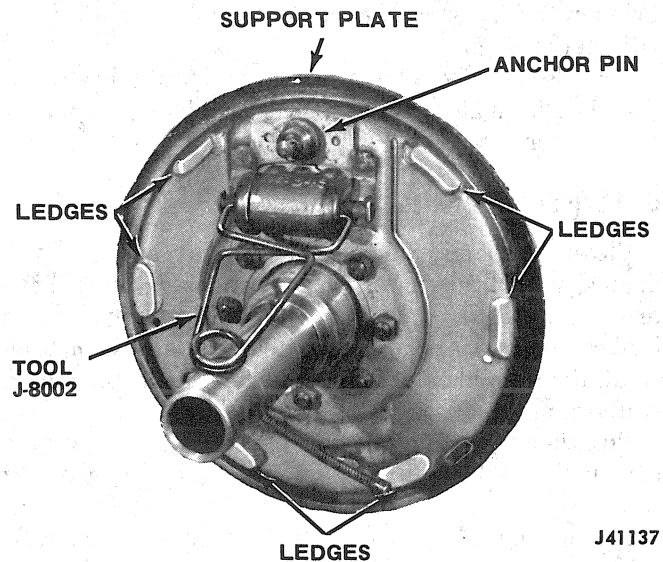

Fig. 2G-29 Wheel Cylinder Clamps Installed

Cleaning and Inspection

Inspect brakelining wear. Replace riveted lining if it is worn to within 1/32 inch (0.79 mm) of the rivet heads. Replace bonded lining if it is worn to a total thickness of approximately 1/16 inch (1.58 mm) or less.

Inspect the lining wear pattern. If wear is uneven across the width of the lining, replace the lining and check the drum for distortion and runout. Inspect the lining for cracks, charred surface, or broken rivets. Replace the lining if contaminated with brake fluid, axle lubricant, or similar contaminants or if the lining exhibits any of the conditions described previously.

Inspect the adjusting screw spring, return springs, holddown springs, actuating lever return spring, and automatic adjuster spring. Replace any springs that are distorted, broken, discolored (overheated), or lack tension.

Inspect the parking brake lever, automatic adjuster lever and pivot, and actuating lever for wear and defects. Replace levers if bent, broken, or excessively worn.

Inspect the adjusting screw pivot and screw threads. The screw must rotate freely. Inspect the screw serrations for excessive wear which could effect automatic adjustment.

Inspect the parking brake cables for being frayed, worn, kinked, or seized. Also check for missing or loose cable end retainer buttons. Inspect the parking brake lever for distortion, worn pivot pin, and for proper cable retention.

Inspect the wheel cylinders for evidence of leakage. Pull back the dust boots and check for signs of leakage past the piston cups. If necessary, overhaul the cylinder as described in this chapter. Inspect the bleeder screw and hydraulic line connection for evidence of leakage or damaged threads. Replace the wheel cylinder if the internal threads are damaged. Check the brake lines for swelling, distortion, kinks, or cracks. Replace any line exhibiting these conditions.

Clean the support plates using shop cloths or compressed air. Polish the anchor pins with crocus cloth and polish the support plate ledges with emery cloth. If the ledges have deep grooves or ridges which might restrict shoe movement, the support plate should be replaced. Do not attempt to reduce deep ridges or grooves by grinding. This can result in improper shoe-to-drum contact. Inspect the support plates for distortion or cracks and check the support plate-to-axle flange bolt torques. Inspect the anchor pins for wear or for being loose. Replace the support plate if it exhibits any of the conditions described previously.

Clean the brakedrums using a soap and water solution only.

CAUTION: Do not use brake fluid, gasoline, kerosene, or similar solvents to clean the drums. Use a soap and water solution only to clean the drums.

Inspect the drums for scoring, cracks, heat checking, hard spots, and distortion and check the drums for excessive runout. Mount the drums on a brake lathe and check runout using a dial indicator. Drum runout must not exceed 0.005 inch (0.12 mm). If drum runout is excessive, replace or remachine the drum.

CAUTION: When machining drums, do not remove more than 0.030 inch (0.76 mm). Maximum allowable oversize for any drum is 0.060 inch (1.52 mm) over original diameter. In addition, do not attempt to machine drums with hard spots. Replace drums with this condition.

Assembly and Adjustment

NOTE: When it is necessary to replace the brakelining on one wheel, the lining must also be replaced on the opposite wheel to maintain braking balance.

(1) Apply thin film of molydisulphide grease, or chassis lubricant to support plate ledges, anchor pin, adjusting screw threads and pivot, adjuster lever-to-

secondary brakeshoe contact surface, parking brake lever pivot and portion of lever that contacts secondary brakeshoe.

(2) Connect parking brake cable to parking brake lever on secondary brakeshoe.

NOTE: When installing the parking brake lever on replacement brakeshoes, pinch the U-clip to retain the lever on the shoe.

(3) Install secondary brakeshoe, automatic adjuster lever, and lever pivot as assembly and install brakeshoe holddown spring.

(4) Install actuating lever and adjusting lever. Install return spring on actuating lever tang. Large end of tapered spring should rest on brakeshoe.

(5) Install primary shoe and holddown spring.

(6) Install guide plate on anchor pin.

(7) Install parking brake strut and spring on brakeshoes.

(8) Install adjusting screw and spring. Short hooked end of spring goes on primary brakeshoe. Long hooked end goes on secondary brakeshoe (fig. 2G-26).

(9) Install return springs and adjuster spring in following sequence (fig. 2G-26):

(a) install adjuster spring.

(b) install secondary brakeshoe return spring on brakeshoe and adjuster spring.

(c) install primary shoe return spring.

CAUTION: Be sure the brakeshoes are seated against the anchor pin after installing the springs.

(10) Perform initial brake adjustment. Refer to Service Brake Adjustment.

(11) Install brakedrums.

(12) If brake lines were disconnected, bleed brakes. Refer to Brake Bleeding.

(13) Install wheels and tires.

(14) Lower vehicle.

(15) Test brake operation before moving vehicle.

(16) Perform final brake adjustment by making 10 to 15 forward and reverse stops to equalize adjustment and until satisfactory brake pedal height is obtained.

NOTE: If the vehicle has an automatic transmission, do not use the forward range to halt reverse movement of the vehicle. This procedure will prevent the automatic adjusters from operating properly resulting in unsatisfactory pedal heights. All stops must be completed.

BRAKEDRUM SERVICE

Inspection and Measurement

(1) Raise and support vehicle.

(2) Remove wheels.

(3) Remove brakedrums.

(4) Clean drums using soap and water solution. If drums are grease or oil contaminated, clean drums with alcohol before cleaning with soap and water.

(5) Inspect drums for cracks, severe scoring, distortion, or hard spots (a series of shiny or dark colored spots on contact surface). Replace drums that exhibit these conditons. If drums appear in good condition, proceed to next step.

(6) Refer to Specifications and measure drum inside diameter. If diameter is within limits and refinishing would not create an oversize condition, proceed to next step. If diameter exceeds limits or if drum needs refinishing but would exceed allowable size limits after machining, replace drum.

(7) Mount drum in lathe according to lathe manufacturer's instructions.

(8) Mount dial indicator on lathe so indicator stylus contacts lining surface of drum; zero dial indicator.

(9) Measure drum radial runout.

(a) Rotate drum 360 degrees and observe readings.

(b) Move indicator stylus until readings have been taken across entire contact surface of drum.

(c) Drum runout must not exceed 0.005 inch (0.12 mm) total indicator reading at any point. Also note if indicator readings increase or decrease greatly as stylus is moved across drum surface. Large changes may indicate tapered or bell-mouthed drum.

(10) If drum is within limits and does not need re-finishing, install drum. If drum is not within limits or is lightly scored, refinish drum. Refer to Brakedrum Refinishing.

Brakedrum Refinishing

(1) Sharpen or replace cutting tool bit if necessary.

(2) Install anti-chatter band on drum.

(3) Machine drum according to lathe manufacturer recommendations for feed and speed. Do not remove more than 0.010 inch (0.25 mm) of stock during any cut.

(4) Check drum radial runout again after completing machining operations.

NOTE: When brakeshoes are replaced on one wheel, they must also be replaced on the opposite wheel to ensure balanced braking.

SPECIFICATIONS

General Specifications

Brake Drum Radial Runout Limit	0.005 inches (0.12 mm)
Brake Drum Internal Diameter Limit:	
CJ Models	10.060 inches (25.5 cm)
Cherokee—Wagoneer—J-10 Truck	11.060 inches (28.09 cm)
J-20 Truck	12.060 inches (30.6 cm)
Brake Lining Wear Limits:	
Riveted Lining	Replace when worn to within 1/32 inch (0.79mm) of rivet heads.
Bonded Lining	Replace when worn to thickness of approximately 1/16 inch (1.58 mm) or less.

80393

Torque Specifications

Service Set-To Torques should be used when assembling components. Service In-Use Recheck Torques should be used for checking a pre-torqued item.

	USA (ft -lbs)		Metric (N-m)	
	Service Set - to Torque	In - Use Recheck Torque	Service Set - to Torque	In - Use Recheck Torque
Brakeline-to-Caliper Fitting Bolt (Cke, Wag, Trk)	160 in-lbs.	120 - 200 in-lbs.	18	14 - 23
Bleeder Screw (1/4 - 28)	45 in-lbs.	40 - 50 in-lbs.	5	5 - 6
Bleeder Screw (3/8 - 24)	90 in-lbs.	40 - 140 in-lbs.	10	5 - 16
Brake Support Plate Mounting Bolts/Nuts (J-20 Trk)	50	45 - 55	68	61 - 75
Brake Support Plate Mounting Bolts/Nuts (Cke, Wag, J10 Trk)	45	35 - 55	61	47 - 75
Brake Support Plate Mounting Bolts/Nuts (CJ)	33	30 - 35	45	41 - 47
Caliper Anchor Bracket to Steering Knuckle (CJ)	85	75 - 95	115	102 - 129
Master Cylinder Mounting Bolts/Nuts	30	25 - 35	41	34 - 47
Master Cylinder-to-Power Unit Mounting Nuts	25	20 - 30	34	27 - 41
Power Brake Unit-to-Dash Mounting Bolts/Nuts	22	18 - 25	30	24 - 34
Brake Line-to-Caliper Fitting Bolt (CJ)	25	20 - 30	34	27 - 41
Brake Line-to-Wheel Cylinder Fitting	160 in-lbs.	120 - 200 in-lbs.	18	14 - 23
Parking Brake Cable Clamp-to-Support Plate Bolts (5/16 - 18)	10	8 - 12	14	11 - 16
Wheel Nuts (CJ)	75	65 - 90	102	88 - 122
Wheel Nuts (Cke, Wag, Trk)	75	65 - 80	102	88 - 108
Wheel Nuts (8400 GVW Trk)	130	110 - 150	176	149 - 203
Brake Pedal-to-Power Unit Push Rod Bolt/Nut	35	25 - 40	47	34 - 54
Caliper Mounting Bolts (Cke, Wag, Trk)	35	30 - 40	47	41 - 54
Caliper Support Key Retaining Screw (CJ)	15	15 - 18	20	20 - 24
Disc. Brake Shield Bolts (Cke, Wag, Trk)	8	5 - 10	11	7 - 14
Disc. Brake Shield Nuts (Cke, Wag, Trk)	35	30 - 40	47	41 - 54
Wheel Bearing Outer Locknut (All)	50(min.)		68 (min.)	
Wheel Bearing Inner Locknut (Bearing Adjuster):				
CJ	Tighten to 50 ft-lbs. (68 N-m) and back off 1/6 turn while rotating wheel.			
Cke, Wag, Trk	Tighten to 50 ft-lbs. (68 N-m) and back off 1/6 turn while rotating wheel.			

All Torque values given in foot-pounds and newton-meters with dry fits unless otherwise specified.

DISC BRAKES

	Page		Page
Brakeshoe Replacement—Cherokee-Wagoneer-Truck Models	2G-44	General	2G-41
Brakeshoe Replacement—CJ Models	2G-48	Disc Brake Operation	2G-43
Caliper Overhaul—Cherokee-Wagoneer-Truck Models	2G-45	Rotor Service	2G-53
Caliper Overhaul—CJ Models	2G-50	Specifications	2G-55

GENERAL

Jeep vehicles are equipped with single piston, floating caliper front disc brakes. Two different calipers are used. On CJ models, the caliper is positioned on abutment surfaces machined into the leading and trailing

edges of the caliper anchor bracket (fig. 2G-30). On Cherokee, Wagoneer, and Truck models, the caliper is positioned on mounting bolts located in the caliper support bracket (fig. 2G-31). Although the two caliper designs differ in construction, caliper operation and service procedures are similar.

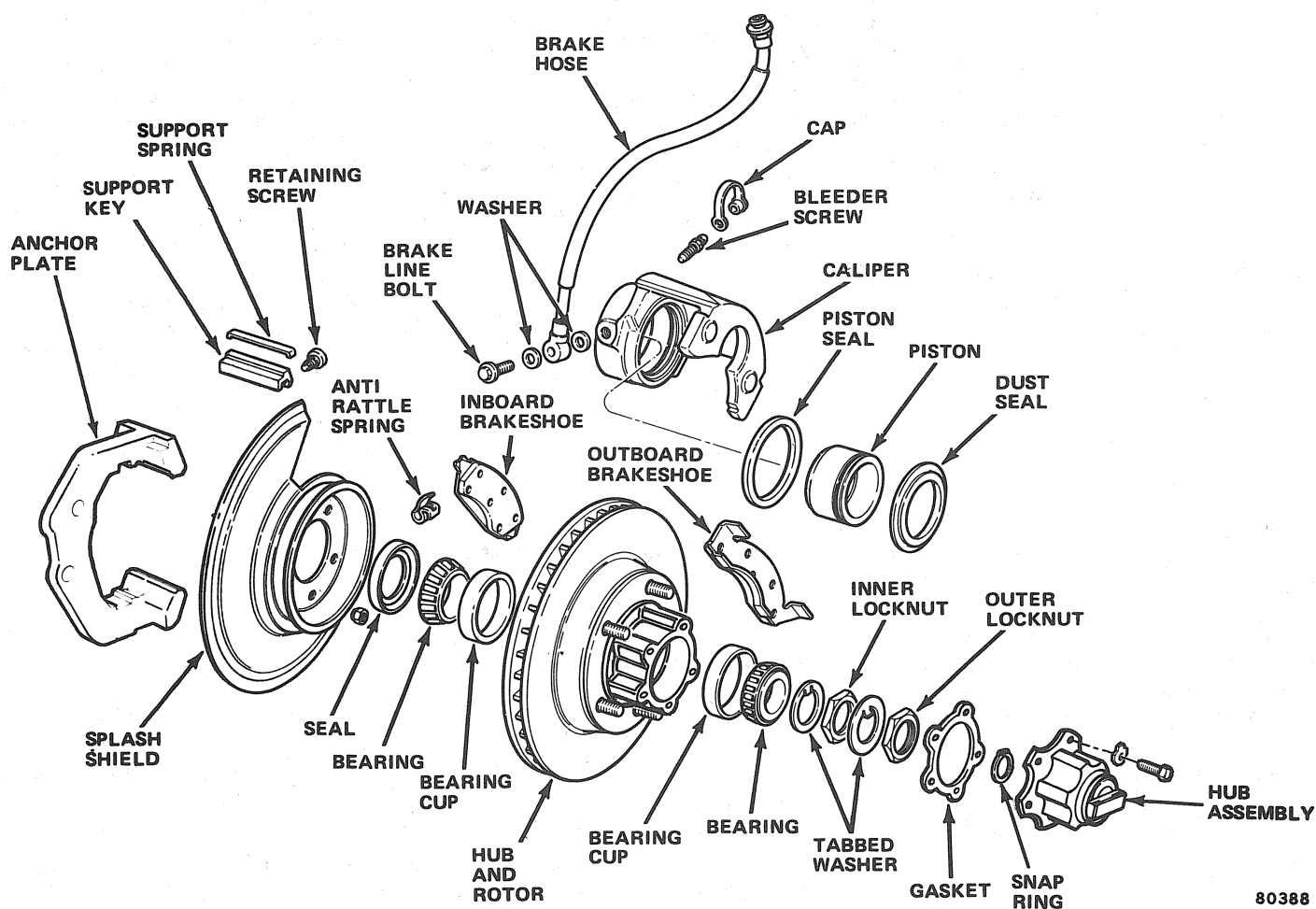
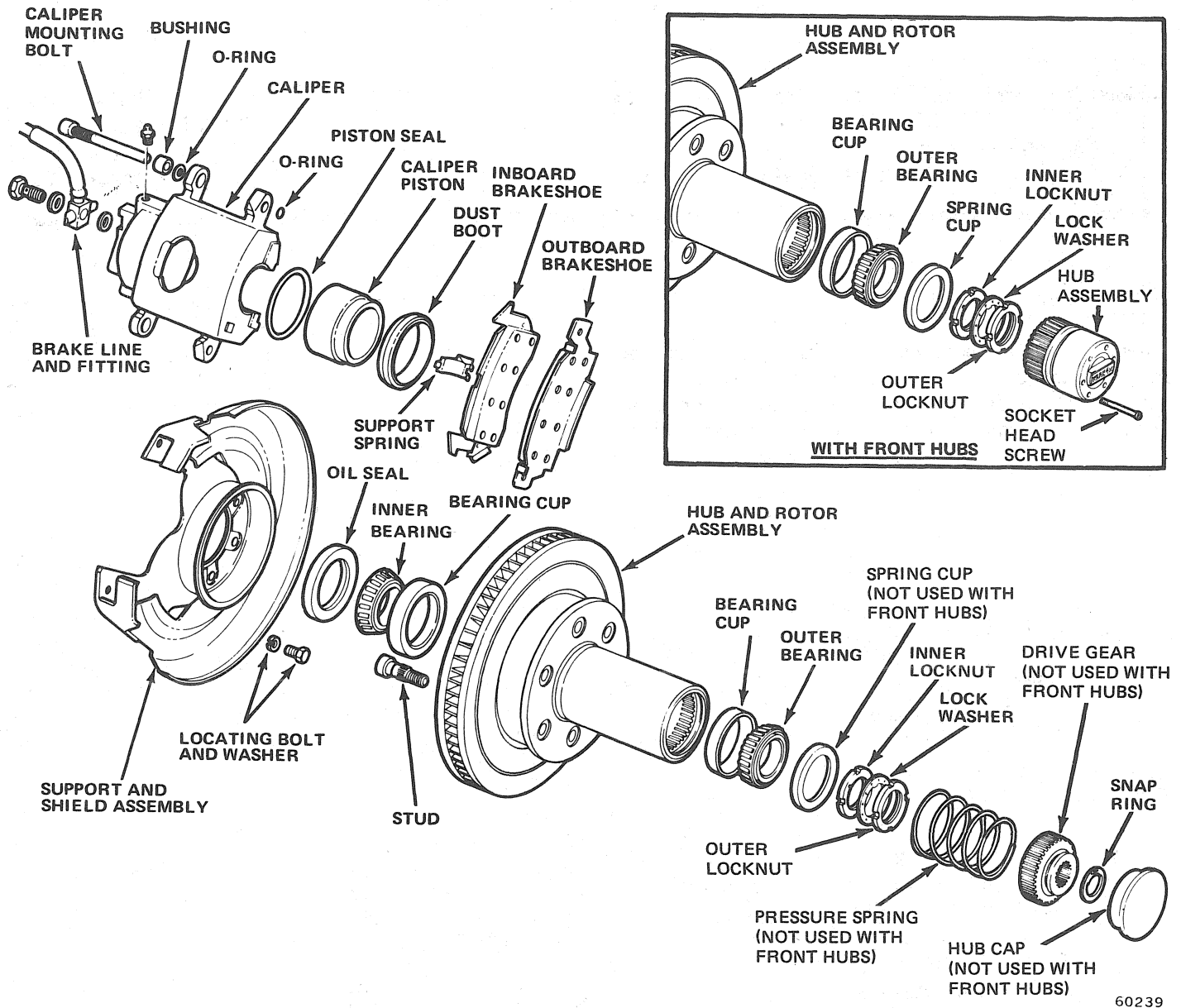

Fig. 2G-30 Disc Brake Assembly—CJ Models



60239

Fig. 2G-31 Disc Brake Assembly—Cherokee-Wagoneer-Truck Models

All models are equipped with an integral-type hub and rotor. CJ models use an 11.7 inch (29.71 cm) rotor. Cherokee, Wagoneer and J-10 Truck models use a 12.0 inch (30.48 cm) rotor. J-20 Truck models use a 12.5 inch (31.75 cm) rotor.

Both caliper types consist of a one-piece casting containing a piston, piston bore, bleeder screw and fluid inlet ports. The piston and piston seal are contained within the piston bore. The piston seal is located in a groove machined in the bore wall. An all-rubber dust boot is used on CJ models while a combination rubber boot with integral metal retainer is used on Cherokee, Wagoneer, and Truck models. The boot is located in a counterbore or groove machined in the upper edge of the

piston bore and in a groove machined in the exterior surface of the piston.

All caliper pistons are precision ground and plated to provide a hard, durable surface. A return spring is not used in the piston bore in either caliper. Lining wear is compensated for by the lateral sliding movement of the caliper and by increased piston extension (fig. 2G-32).

A brakelining wear sensor, which consists of a strip of flanged metal, is attached to the inboard brakeshoe on Cherokee, Wagoneer and Truck models (a sensor is not used on CJ model lining). When the brakelining wears to the point of replacement, the sensor contacts the rotor surface making a high-pitched noise to alert the driver (fig. 2G-33).

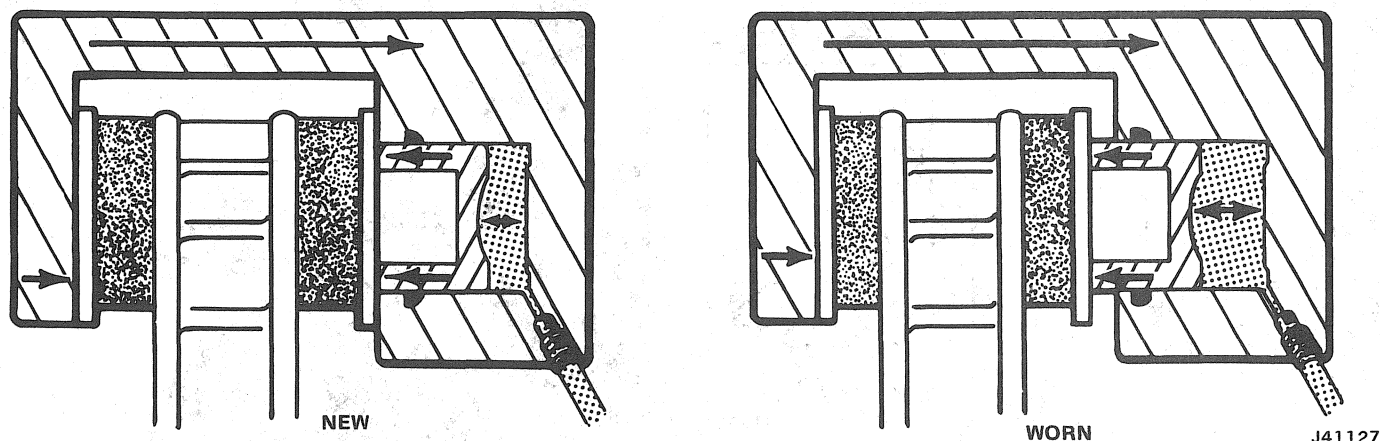

Fig. 2G-32 Piston Extension—Now and Worn Linings

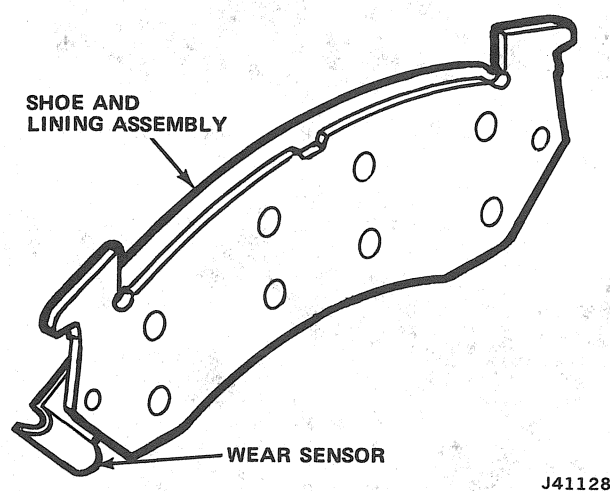

Fig. 2G-33 Brake Lining Wear Sensor
Location—Cherokee-Wagoneer-Truck Models

Any application or release of brake apply pressure produces very slight piston and caliper movement. At release, the piston and caliper return to a neutral position. Cherokee, Wagoneer and J-10 Truck models are equipped with low drag calipers. The caliper piston seal in this caliper design retracts each caliper piston more fully than in previous designs. The result is less vehicle rolling resistance because brake lining drag on each brake rotor is reduced.

As the linings wear, the piston extends farther out of the caliper bore causing the caliper to reposition itself to maintain lining-to-rotor clearance. When the piston extends, additional brake fluid flows into the bore to compensate for the increase in bore volume caused by piston extension (fig. 2G-32).

DISC BRAKE OPERATION

Operation

The significant feature of disc brake operation is that the caliper is free to slide laterally on the mounting bolts or anchor plate abutment surfaces.

When the brakes are applied, fluid pressure is exerted equally against the piston and piston bore surfaces. Pressure applied to the piston is transmitted to the inboard shoe and lining pressing the lining against the rotor inboard surface. At the same time, pressure applied to the piston bore forces the caliper to slide inboard. This movement causes the outboard portion of the caliper to press the outboard shoe and lining assembly against the rotor outboard surface.

Wear Compensation

The piston seal maintains operating clearance between the rotor and lining and adjusts for wear during each brake application. When the brakes are applied, the seal is deflected by hydraulic pressure and by friction between the piston and seal. When hydraulic pressure is released, the seal reverts to its original shape and retracts the piston just enough to provide the necessary operating clearance.

As the linings wear, piston travel begins to exceed the seal deflection limit. The piston then moves outward through the seal just far enough to compensate for lining wear and reestablish normal seal deflection (fig. 2G-34).

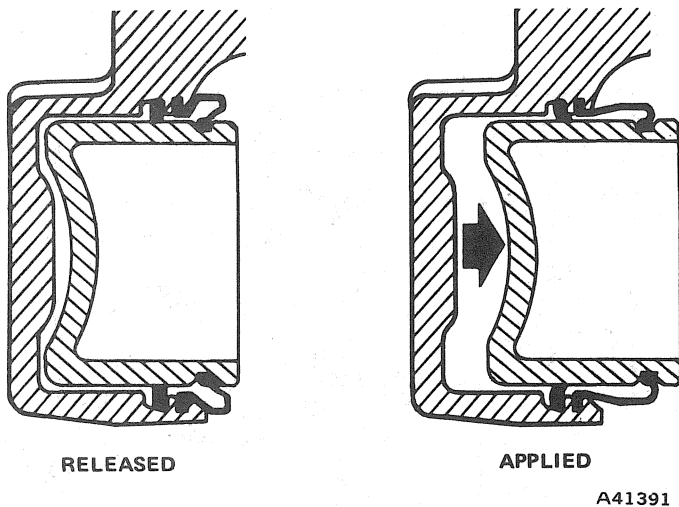

Fig. 2G-34 Piston and Seal Movement

BRAKESHOE REPLACEMENT—CHEROKEE-WAGONEER-TRUCK MODELS

WARNING: When servicing wheel brake parts, do not create dust by grinding or sanding brakelinings or by cleaning wheel brake parts with a dry brush or with compressed air. Use water dampened shop cloths only to remove dirt and dust from brake parts prior to disassembly. Many wheel brake parts contain asbestos fibers which can become airborne if dust is created during servicing operations. Breathing dust containing asbestos fibers may cause serious bodily harm.

- (1) Remove two-thirds of brake fluid from master cylinder front reservoir.
- (2) Raise vehicle.
- (3) Remove front wheel and tire.
- (4) Bottom caliper piston in bore. Insert screwdriver between piston and inboard shoe and press piston into bore. If piston is difficult to move using screwdriver, use large C-clamp.
- (5) Remove caliper mounting bolts using hex wrench (fig. 2G-35).
- (6) Remove caliper by lifting it upward and out of shield and support (fig. 2G-36). Place caliper on front spring or other suitable support. Do not allow brake hose to support weight of caliper.
- (7) Remove brakeshoes from caliper.
- (8) Remove support spring from inboard shoe. Note spring position for assembly reference (fig. 2G-36).
- (9) Remove sleeves and rubber bushings from mounting bolt bores in caliper mounting ears (fig. 2G-30).
- (10) Clean mounting bolts, bolt bores, and bushing grooves in caliper mounting ears with brake cleaning solvent. Replace mounting bolts if corroded or if threads are damaged.

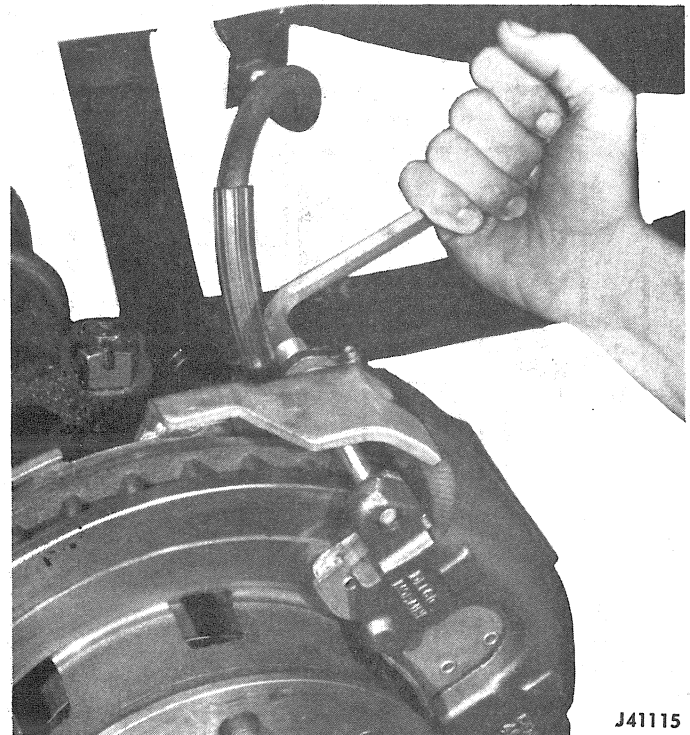

Fig. 2G-35 Caliper Mounting Bolt Removal

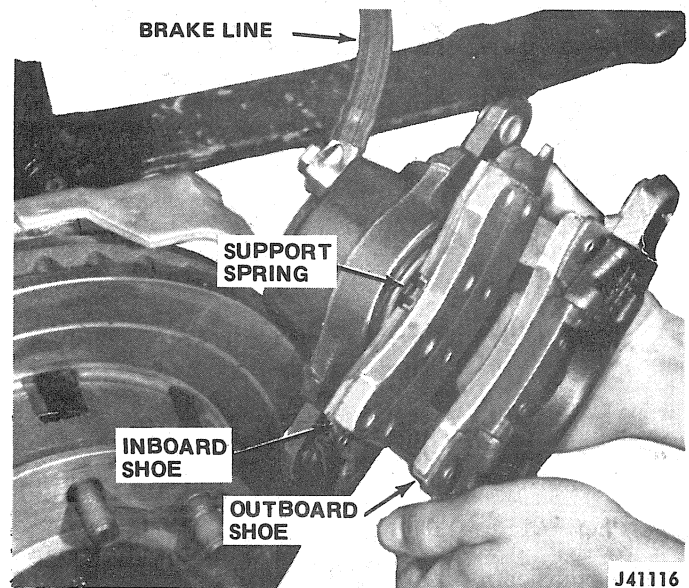

Fig. 2G-36 Caliper Removal

NOTE: Do not use abrasives to clean or polish the mounting bolts. Abrasives will destroy the protective plating on the bolts.

- (11) Clean caliper interior and dust boot using shop cloths only. Inspect dust boot for cuts, cracks, and for proper seating in piston bore. If evidence of fluid leakage is noted during inspection, overhaul caliper.

CAUTION: Do not use compressed air to clean the caliper interior or dust boot. The force of compressed air will unseat the boot. Use shop cloths only.

(12) Lubricate replacement bushings, sleeves, bushing grooves, and small ends of mounting bolts with silicone lubricant.

(13) Install rubber bushings in caliper mounting ears.

CAUTION: Do not use the original old bushings or sleeves. Use replacement parts only.

(14) Install sleeves in inboard mounting ears of caliper. Position sleeves with sleeve end facing shoe and lining flush with machined surface of mounting ear.

(15) Install support spring on inboard shoe. Place single tang end of spring over notch in shoe (fig. 2G-37).

(16) Install inboard shoe in caliper (fig. 2G-38). Be sure shoe is flush against piston and that support spring is fully seated in piston (fig. 2G-38).

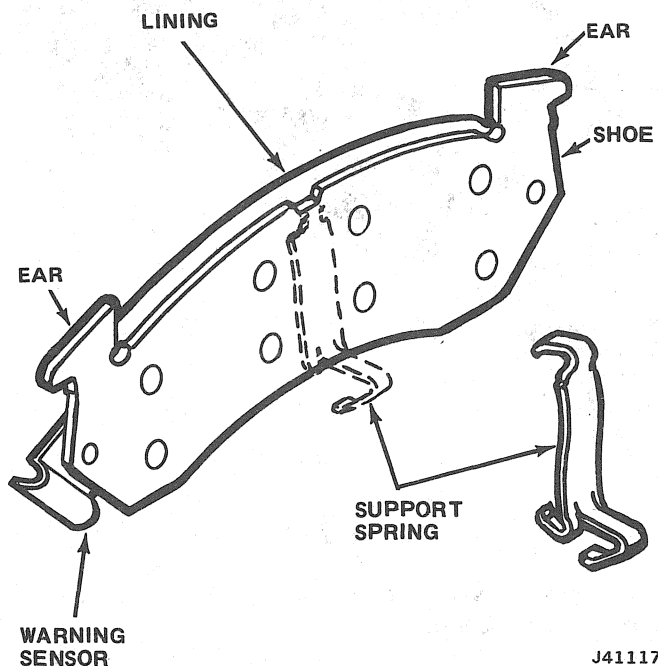

J41117

Fig. 2G-37 Support Spring Installation

(17) Install outboard shoe. Shoe ears should rest on upper surface of caliper mounting ears and lower shoe tab should fit into cutout in caliper. Be sure shoe is fully seated.

(18) Position caliper over rotor and in support shield and bracket. Align mounting holes in caliper and bracket.

(19) Install caliper mounting bolts. Be sure bolts pass under inboard shoe retaining ears and insert bolts until they enter bores in outboard shoe and caliper mounting ears. Thread bolts into support bracket and tighten to 35 foot-pounds (47 N•m) torque.

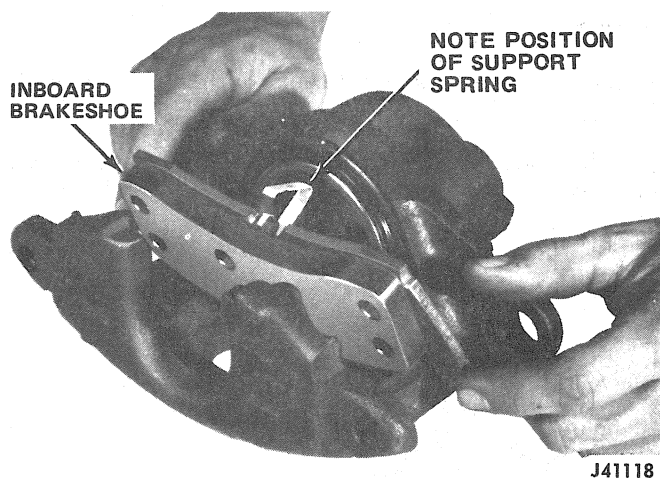

J41118

Fig. 2G-38 Inboard Brakeshoe Installation

(20) Fill master cylinder with brake fluid and pump brake pedal to seat shoes.

(21) Clinch upper ears of outboard shoe until radial clearance between shoe and caliper is eliminated.

NOTE: Outboard shoes with formed ears are designed for original installation only and are fitted to the caliper. These shoes should never be relined or reconditioned for future installation.

(22) Install wheel and tire.

(23) Lower vehicle.

(24) Check master cylinder fluid level. Add fluid as required to within 1/4 inch (6.35 mm) of reservoir rim.

(25) Apply brakes several times to seat brakeshoes.

(26) Check and correct master cylinder fluid level as necessary.

(27) Test brake operation before moving vehicle.

CALIPER OVERHAUL—CHEROKEE-WAGONEER-TRUCK MODELS

Removal

(1) Remove two-thirds of brake fluid from master cylinder front reservoir.

(2) Raise vehicle.

(3) Remove wheel and tire.

(4) Bottom caliper piston using screwdriver or large C-clamp.

(5) Clean brake line hose connection thoroughly using shop cloth.

(6) Disconnect brake line at caliper. Remove brake line bolt and copper gaskets. Discard copper gaskets.

(7) Cap or tape open end of brake hose to prevent dirt entry.

(8) Remove caliper and remove brakeshoes from caliper.

NOTE: Work on one caliper at a time only. If shoes are to be reused, mark their location for assembly reference.

Disassembly

- (1) Clean caliper exterior with brake cleaning solvent.
- (2) Drain remaining fluid from caliper and place caliper on clean work surface.
- (3) Pad caliper interior with clean shop cloths (fig. 2G-39).

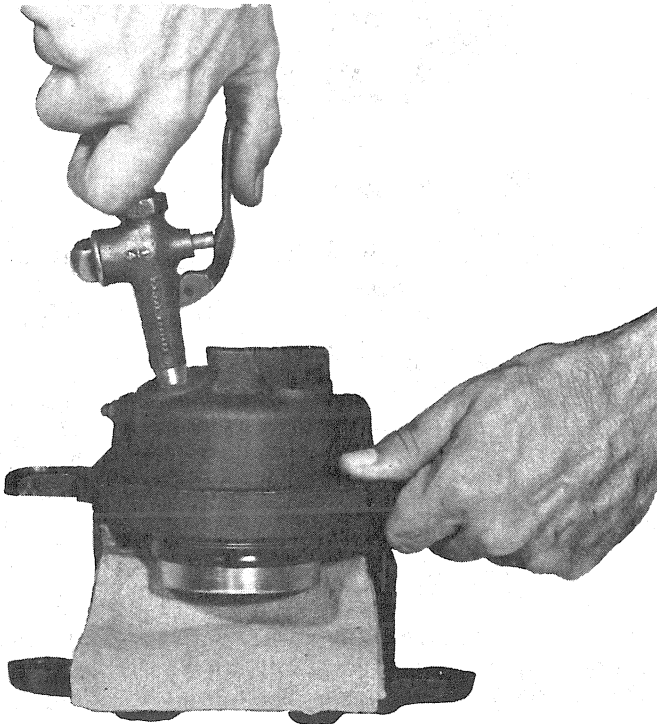

J41162

Fig. 2G-39 Piston Removal

WARNING: Do not, under any circumstances, place fingers in front of the piston in an attempt to catch or protect it. In addition, use only enough air pressure to ease the piston out of the bore. Excessive air pressure can eject the piston with enough force to cause damage or injury.

- (4) Insert air nozzle into caliper fluid inlet hole and slowly apply just enough air pressure to ease piston out of bore (fig. 2G-39).
- (5) Remove and discard dust boot. Use screwdriver to pry boot from bore (fig. 2G-40). Do not scratch piston bore during boot removal.
- (6) Remove and discard piston seal. Use pencil or similar wood implement to remove seal (fig. 2G-41).

CAUTION: Remove the seal using a pencil, wooden stick, piece of plastic, or similar tool only. Do not use a

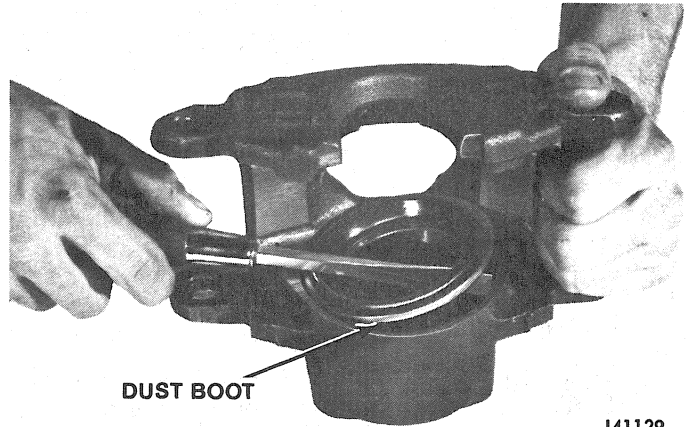

J41129

Fig. 2G-40 Dust Boot Removal

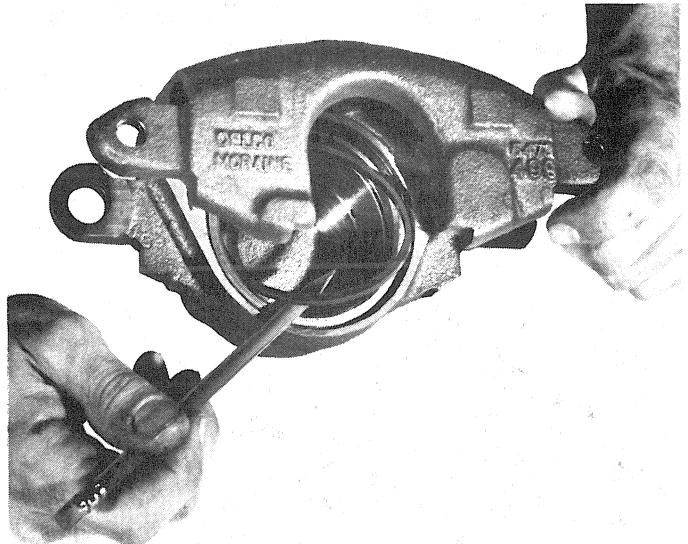

J41130

Fig. 2G-41 Piston Seal Removal

metal tool or similar object to remove the seal as the bore could be scored.

- (7) Remove bleeder screw.
- (8) Remove and discard sleeves and rubber bushings from caliper mounting ears.

Cleaning and Inspection

Clean all parts in brake cleaning solvent or clean brake fluid only. Blow out all caliper passages using filtered compressed air only.

Replace the mounting bolts if corroded or if the threads are damaged. Do not attempt to clean or polish the mounting bolts with abrasives as the protective plating will be removed.

Inspect the caliper piston. Replace the piston if nicked, scratched, corroded, or if the protective plating has worn off.

CAUTION: Do not attempt to refinish the piston in any way. The outside diameter is the sealing surface and is manufactured to very close tolerances. Removal of the nickel-chrome protective plating will lead to pitting, rusting, and eventual piston seizure.

Inspect the piston bore. Replace the caliper if the bore is nicked, scratched, worn, cracked, or badly corroded. However, minor stains or corrosion can be removed using crocus cloth.

CAUTION: Do not use emery cloth or similar abrasives on the piston bore. If the bore does not clean up with crocus cloth, replace the caliper. Clean the caliper thoroughly with brake fluid or brake cleaning solvent if the bore was polished.

Assembly

(1) Lubricate piston bore and replacement seal with brake fluid.

(2) Install seal in bore groove. Work seal into groove using fingers only.

(3) Lubricate piston with brake fluid.

(4) Install replacement dust boot on piston. Slide metal retainer portion of boot over open end of piston and pull boot rearward until rubber boot lip seats in piston groove (fig. 2G-42).

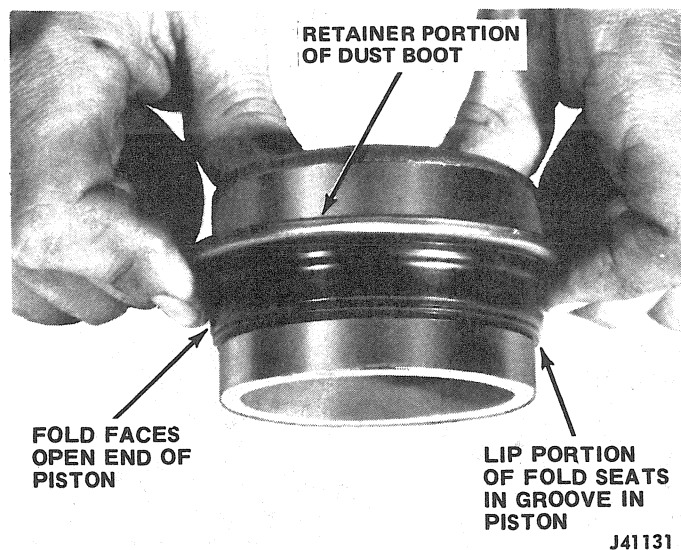

Fig. 2G-42 Installing Dust Boot on Piston

(5) Push metal retainer portion of boot forward until retainer is flush with rim at open end of piston and boot fold snaps into place (fig. 2G-43).

(6) Insert piston into bore and into piston seal. Do not unseat seal.

(7) Press piston to bottom of bore using hammer handle. Approximately 50 to 100 pounds (23 to 45 kg) of force is required to bottom piston in bore.

(8) Seat metal retainer portion of dust boot in counterbore at upper end of piston bore using tool J-22904 (fig. 2G-44).

CAUTION: The metal portion of the dust boot must be seated evenly and below the face of the caliper.

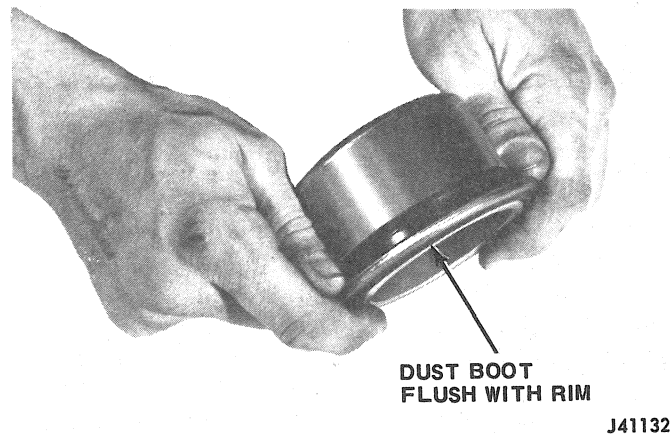

Fig. 2G-43 Snapping Dust Boot Fold in Place

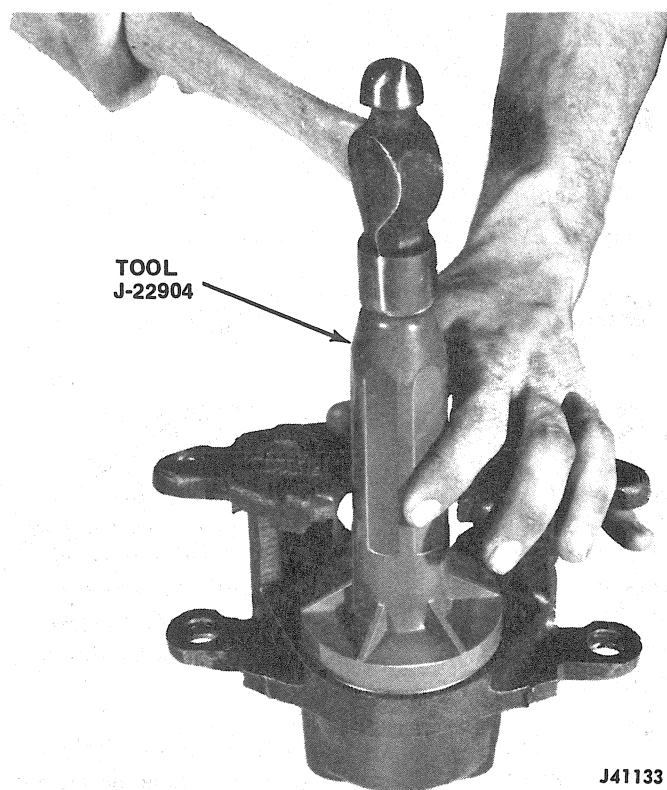

Fig. 2G-44 Seating Dust Boot in Counterbore

(9) Install bleeder screw. Tighten screw securely but not to required torque until brakes have been bled.

Installation

(1) Install replacement copper gaskets on brake line and connect line to caliper. Tighten brake line bolt to 160 inch-pounds (18 N•m) torque.

- (2) Install brakeshoes, and replacement sleeves and bushings as outlined in Brakeshoe Replacement.
- (3) Position caliper on rotor and support bracket and install caliper mounting bolts. Tighten bolts to 35 foot-pounds (47 N•m) torque.
- (4) Bleed brakes as outlined in Brake Bleeding.
- (5) Install wheel and tire.
- (6) Lower vehicle.
- (7) Check brake operation before moving vehicle.

BRAKESHOE REPLACEMENT—CJ MODELS

WARNING: When servicing wheel brake parts, do not create dust by grinding or sanding brakelinings or by cleaning brake parts with a dry brush or with compressed air. Use a water dampened cloth only to remove dirt and dust from brake parts prior to disassembly. Many brake parts contain asbestos fibers which can become airborne if dust is created during service operations. Breathing dust containing asbestos fibers may cause serious bodily harm.

- (1) Remove and discard two thirds of fluid from largest master cylinder reservoir.
- (2) Remove hub cap and loosen wheel retaining nuts.
- (3) Raise vehicle.
- (4) Remove front wheels.

NOTE: Work on one caliper at a time only.

- (5) Press caliper piston to bottom of bore using screwdriver (fig. 2G-45). If piston is difficult to move, use large C-clamp.

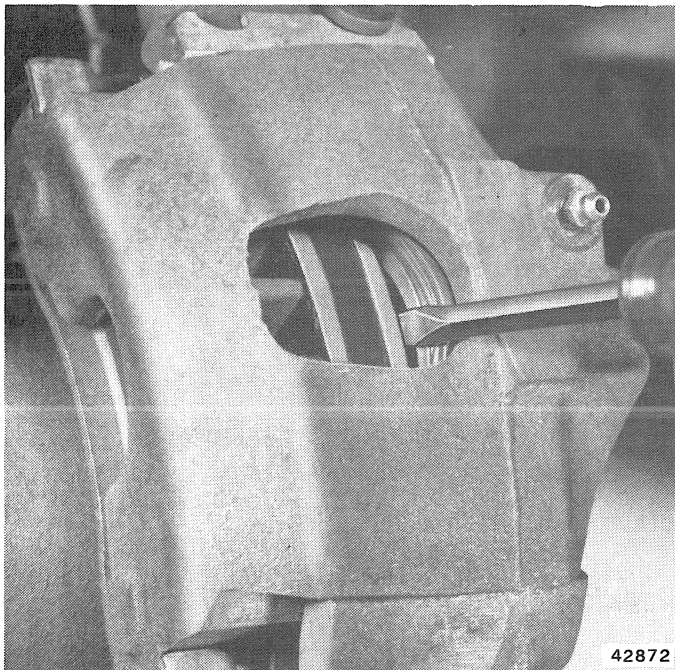

Fig. 2G-45 Bottoming Caliper Piston

- (6) Remove caliper support key retaining screw using 1/4 hex wrench (fig. 2G-46).

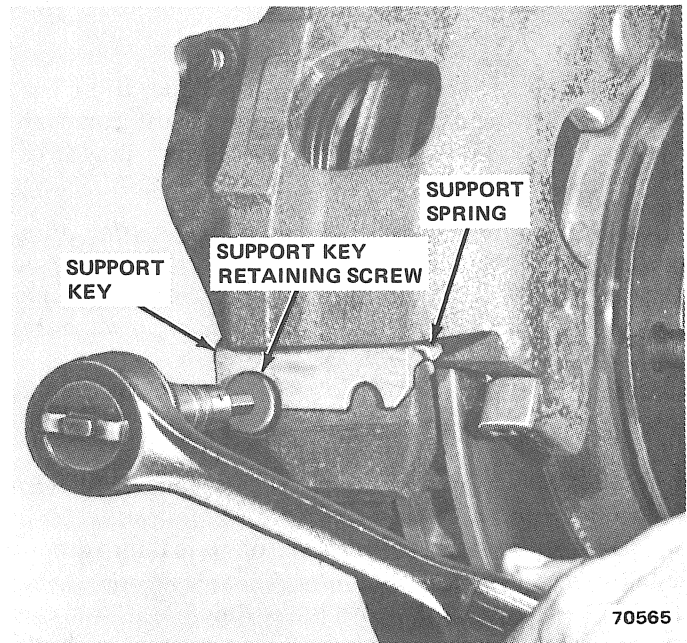

Fig. 2G-46 Support Key Retaining Screw Removal

- (7) Remove caliper support key and spring using punch and hammer (fig. 2G-47).
- (8) Lift caliper upward and out of anchor plate and off of rotor (fig. 2G-48).
- (9) Place caliper on front suspension spring. Do not let brake hose support weight of caliper.
- (10) Remove inboard brakeshoe from anchor plate (fig. 2G-49).

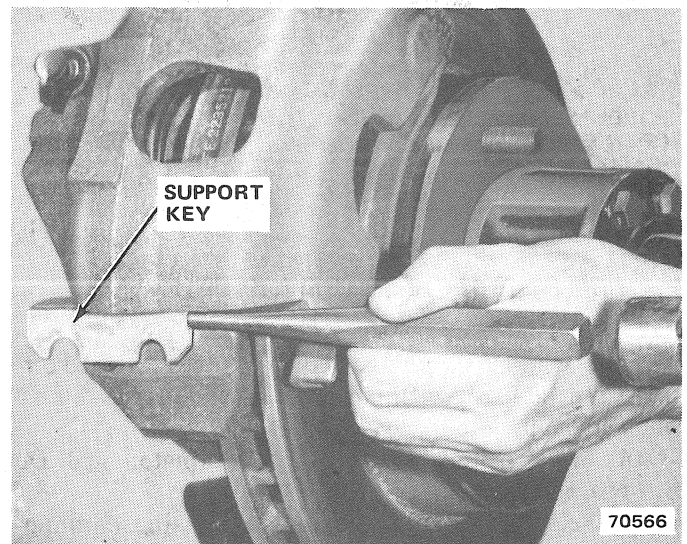

Fig. 2G-47 Support Key and Spring Removal

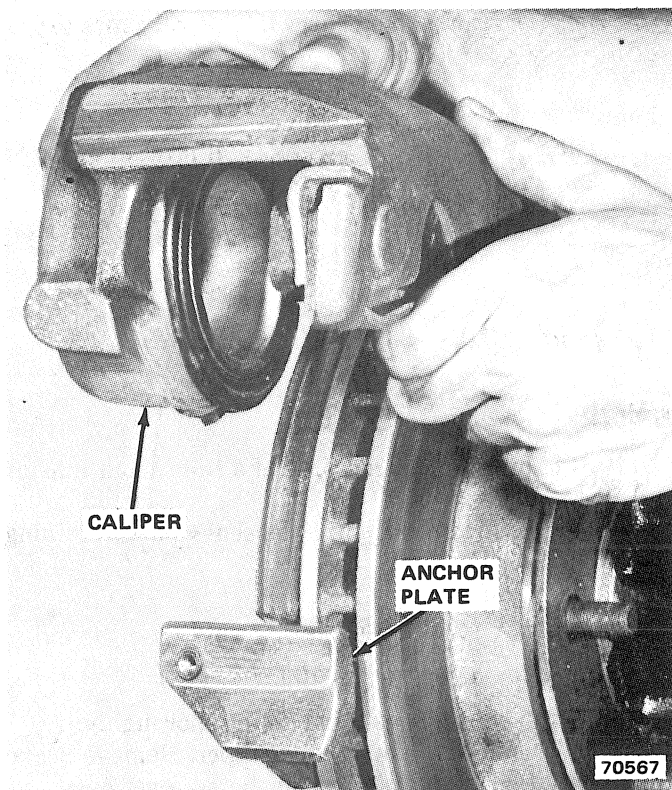

Fig. 2G-48 Caliper Removal/Installation

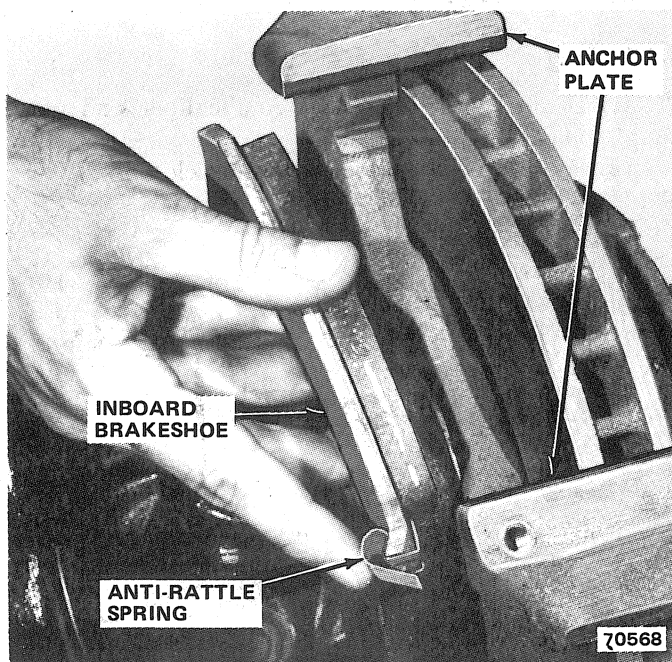

Fig. 2G-49 Inboard Brakeshoe and Anti-Rattle Spring Removal

(11) Remove anti-rattle spring from inboard brakeshoe (fig. 2G-49). Note spring position for assembly reference.

(12) Remove outboard brakeshoe from caliper.

(13) Clean caliper interior using shop cloths only.

CAUTION: Do not use compressed air to clean the caliper interior. The force of compressed air is enough to dislodge or damage the dust boot.

(14) Inspect caliper for evidence of leakage from piston bore. If leakage is evident, overhaul caliper. Refer to Caliper Overhaul—CJ Models.

(15) Inspect abutment (sliding) surfaces of caliper and anchor plate for rust or corrosion (fig. 2G-50). Clean these surfaces using stiff wire brush and fine grit sandpaper and lubricate them with molydisulphide grease.

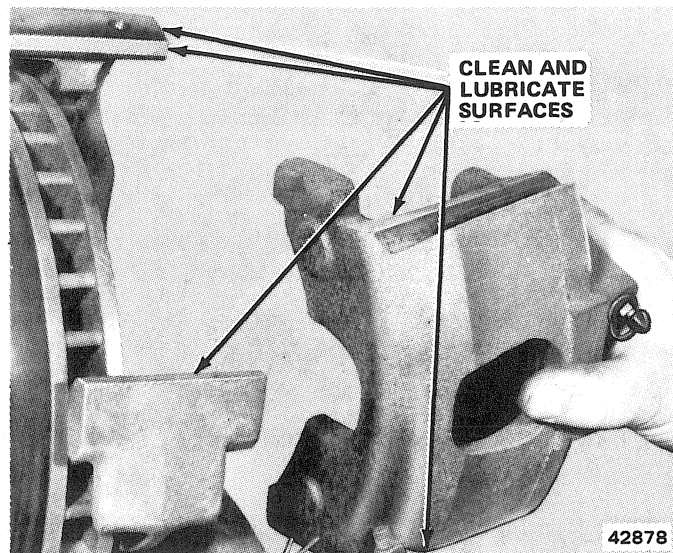

Fig. 2G-50 Abutment Surfaces

CAUTION: It is important that the abutment surfaces be clean, smooth, and lubricated with molydisulphide grease. Rust, corrosion, or foreign material on these surfaces will impair the sliding action of the caliper in the anchor plate.

(16) Install inboard brakeshoe anti-rattle spring on rear flange of inboard brakeshoe. Be sure looped section of spring faces away from rotor (fig. 2G-51).

(17) Install assembled inboard brakeshoe and anti-rattle spring in caliper anchor plate (fig. 2G-49). Do not dislodge anti-rattle spring during shoe installation.

(18) Install outboard brakeshoe in caliper (fig. 2G-52).

(19) Install caliper over rotor and in anchor plate (fig. 2G-48).

CAUTION: Be very careful to avoid tearing or dislodging the dust boot when installing the caliper. A damaged or displaced boot will expose the caliper piston to road splash resulting in corrosion and eventual piston seizure.

(20) Align caliper and anchor plate and insert support key and spring between abutment surfaces at trailing end of caliper (fig. 2G-46).

ANTI-RATTLE SPRING

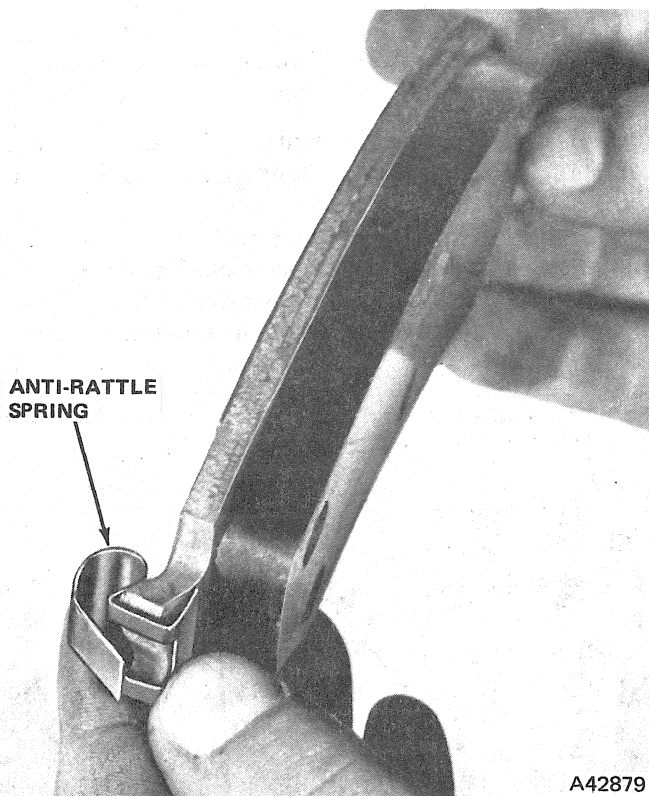

A42879

Fig. 2G-51 Installing Anti-Rattle Spring on Inboard Brakeshoe

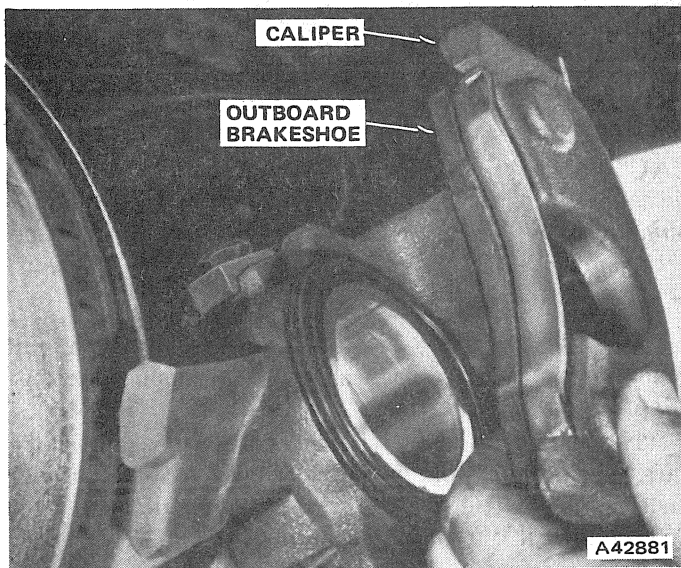

A42881

Fig. 2G-52 Inboard Brakeshoe Installation

(21) Complete installation of support key and spring using hammer and punch.

(22) Install support key retaining screw and tighten screw to 15 foot-pounds (20 N•m) torque. Be sure screw is properly seated in support key notch before tightening.

(23) Fill master cylinder reservoir to within 1/4 inch (6.35 mm) of reservoir rim.

(24) Press firmly on brake pedal several times to seat shoes.

(25) Install wheels and tires.

(26) Lower vehicle.

(27) Recheck master cylinder fluid level and correct if necessary.

CAUTION: Check for a firm brake pedal before moving the vehicle.

CALIPER OVERHAUL—CJ MODELS

Removal

(1) Remove two-thirds of brake fluid from master cylinder front reservoir.

(2) Remove hub cap and loosen wheel retaining nuts.

(3) Raise and support vehicle.

(4) Remove front wheels.

NOTE: Work on one caliper at a time only.

(5) Clean caliper brake line fitting thoroughly.

(6) Disconnect brake line at caliper. Remove brake line bolt and washers. Discard washers. Cover open end of brake line with cloth or tape.

(7) Remove caliper and brakeshoes as outlined in Brakeshoe Replacement—CJ Models.

Disassembly

(1) Drain remaining fluid from caliper and place caliper on clean work surface.

(2) Pad caliper interior with shop cloths (fig. 2G-53).

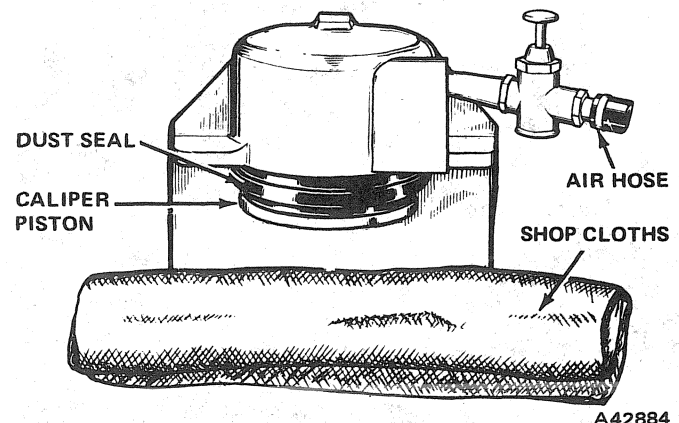

A42884

Fig. 2G-53 Caliper Piston Removal

(3) Insert air nozzle in caliper fluid inlet port and slowly apply just enough air pressure to ease piston out of bore.

WARNING: Do not, under any circumstances, place fingers in front of the piston in an attempt to catch or protect it. In addition, use only enough air pressure to

ease the piston out of the bore. Excessive air pressure can eject the piston with enough force to cause damage or personal injury.

(4) Remove and discard dust boot (fig. 2G-54).

(5) Remove piston seal from bore using plastic or wood tool only. Discard piston seal.

CAUTION: Do not use metal tools to remove the piston seal. Metal tools may damage the piston bore.

(6) Remove bleeder screw protective cap and bleeder screw.

Cleaning and Inspection

Remove rust and corrosion from the caliper and anchor plate abutment surfaces using a wire brush and fine grit sandpaper and lubricate these surfaces with molydisulphide grease (fig. 2G-50).

Clean the caliper and piston with brake cleaning solvent and dry both parts using filtered compressed air. Be sure to blow out all passages in the caliper.

Inspect the caliper piston for damage. Replace the piston if worn, scored, pitted, or corroded.

Inspect the caliper for damage. Replace the caliper if the bore or seal grooves are worn, nicked, pitted, or badly corroded. Minor corrosion in the bore can be removed using a fiber brush only.

Inspect the anti-rattle spring, support key, support key spring, and support key retaining screw. Replace any parts that are damaged or worn. Replace the support spring and anti-rattle springs if they are flattened, distorted, or lack tension.

Assembly

(1) Lubricate piston bore and replacement piston seal with brake fluid.

(2) Install piston seal in bore. Work seal into groove using fingers only.

(3) Install bleeder screw and protective cap.

(4) Install caliper piston and replacement dust boot using Installer Tool J-24837. Refer to Piston and Boot Replacement with Installer Tool J-24837.

NOTE: If a boot installer tool is not available, refer to Piston and Boot Installation without Installer Tool.

(1) Lubricate piston and replacement dust boot with brake fluid.

(2) Mount dust boot on Installer Tool J-24837 (fig. 2G-55). Allow approximately 1/4 inch (6.35 mm) of tool to extend beyond small lip of dust boot.

(3) Position assembled boot and installer tool over piston bore. Reach through installer tool and work large lip of boot into boot groove in upper edge of piston bore (fig. 2G-56). Be sure boot is completely seated in groove.

(4) Lubricate caliper piston with brake fluid.

(5) Insert piston through installer tool and center piston in bore.

(6) Press piston half-way into bore. Use hammer handle and steady pressure to install piston (fig. 2G-57). Do not strike hammer handle or piston to install. Piston must be pressed into bore only.

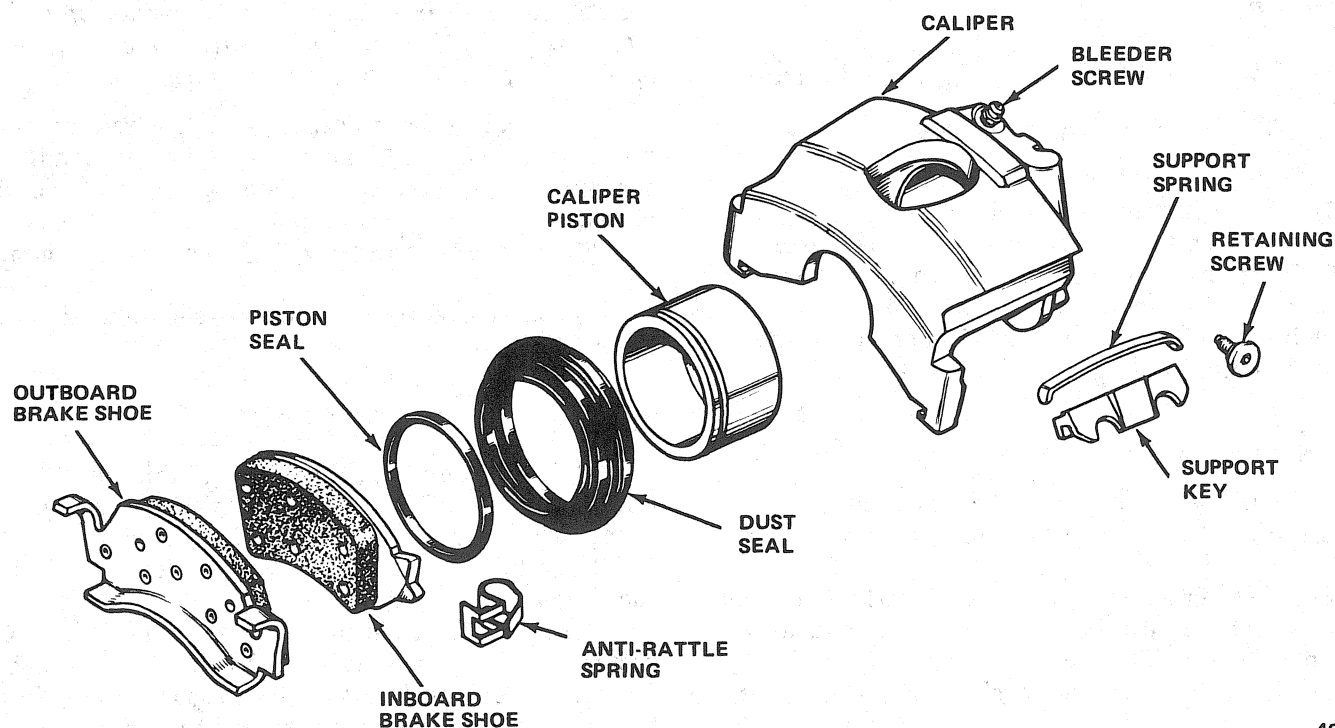

Fig. 2G-54 Caliper Assembly—CJ Models

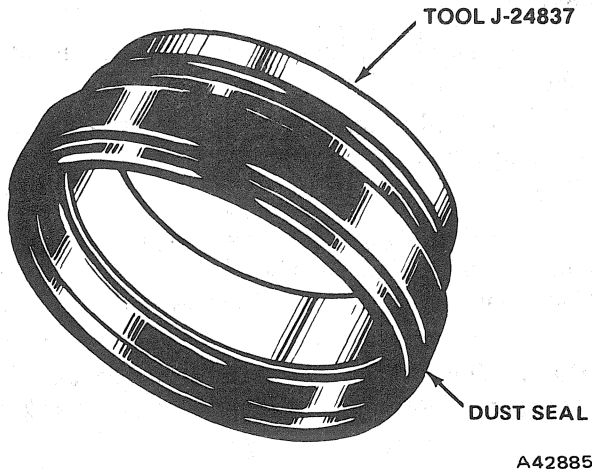

Fig. 2G-55 Positioning Dust Seal on Installer Tool

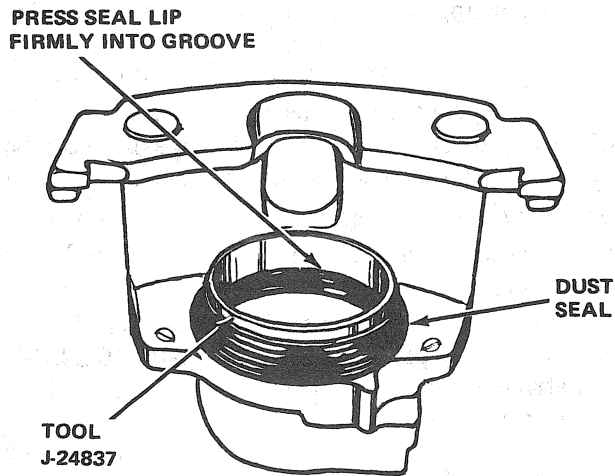

Fig. 2G-56 Dust Seal Installation

- (7) Remove boot installer tool.
- (8) Seat rubber lip of dust boot in piston groove.
- (9) Press piston to bottom of bore using hammer handle.
- (10) Inspect rotor and install caliper and brakeshoes. Refer to Installation.

Piston and Boot Installation without Installer Tool

- (1) Lubricate piston bore with brake fluid.
- (2) Position dust boot on piston bore. Do not lubricate boot.
- (3) Reach through top of boot and work large lip of boot into boot groove at upper edge of bore. Be sure boot is completely seated in groove.
- (4) Lubricate piston and small lip of dust boot with brake fluid.
- (5) Position piston over small lip of boot.

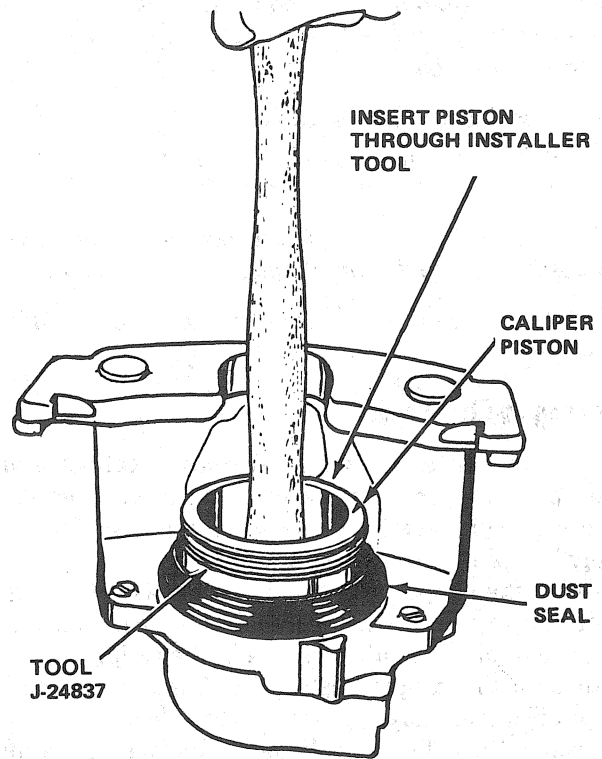

Fig. 2G-57 Caliper Piston Installation

(6) Hold piston in position over boot lip and direct reduced air pressure of approximately 15 psi (103 kPa) compressed air into caliper fluid inlet port.

NOTE: Reduce air pressure to a maximum of 15 psi (103 kPa) by closing air supply valve completely; then opening it approximately 1/4 to 1/2 turn.

- (7) As air pressure expands boot, carefully work piston into boot until boot lip seats in piston groove. When boot lip is seated in piston groove, release air pressure.
- (8) Press piston to bottom of bore using hammer handle.
- (9) Inspect rotor and install caliper and brakeshoes. Refer to Installation.

Installation

- (1) Check rotor lateral runout and thickness variation. Inspect rotor for scoring, cracks, and broken ventilating ribs. Refer to Rotor Service for procedures.
- (2) Install brakeshoes and caliper. Refer to Brake-shoe Replacement—CJ Models.
- (3) Install replacement washers on brake line connector or fitting and connect brake line to caliper. Tighten brake line bolt to 160 inch-pounds (18 N•m) torque. Or, if equipped with brake line fitting, tighten fitting to 25 foot-pounds (34 N•m) torque.

- (4) Fill master cylinder to within 1/4 inch (6.35 mm) of reservoir rims.
- (5) Press brake pedal firmly several times to seat brakeshoes.
- (6) Refill master cylinder if necessary and bleed brakes. Refer to Brake Bleeding.
- (7) Install wheels.
- (8) Lower vehicle.
- (9) Check brake operation before moving vehicle.

ROTOR SERVICE

Rotor Inspection

- (1) Raise and support front of vehicle.
- (2) Remove front wheels.
- (3) Remove caliper (do not disconnect brake line).
- (4) Inspect rotor braking surfaces. If surfaces are only lightly rusted or scored, proceed to step (5). If surfaces are severely scored, cracked, chipped, excessively worn, or have hard spots (a series of shiny or dark colored spots), replace rotor.
- (5) If rotor surfaces are only lightly scaled, rusted or scored, remove rotor, bearings and seal from rotor. Clean rotor hub bearing surfaces and mount rotor in brake lathe. Clean surfaces using flat sanding discs while rotor is turning in lathe.
- (6) Remove rotor from lathe.
- (7) Check rotor thickness at center of lining contact area. Thickness must be larger than minimum (replacement) specification and provide sufficient stock for refinishing if necessary. If rotor is within limits, proceed to next step. If rotor is less than minimum thickness specification or refinishing would leave it below minimum thickness specification, replace rotor.
- (8) Install bearings and seal in rotor.
- (9) Install rotor on steering spindle and check runout and thickness variation. Refer to Specifications for Tolerances.

Rotor Measurement

- (1) Measure rotor lateral (face) runout (fig. 2G-58).
 - (a) Mount dial indicator on support stand or steering spindle.
 - (b) Position indicator stylus so it contacts center of rotor lining contact area and zero indicator.
 - (c) Turn rotor 360 degrees and note indicator reading. Runout must not exceed limit stated in Rotor Specifications.
 - (d) Refinish rotor if runout exceeds stated limit. Replace rotor if runout is so severe that machining would cause rotor to fall below minimum (replacement) thickness specification. Refer to Rotor Specifications.
 - (e) If runout is within limits, proceed to step (2).

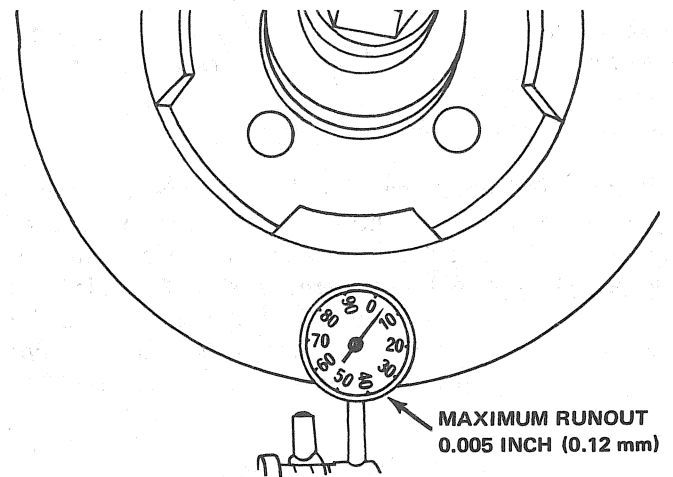

42889

Fig. 2G-58 Checking Lateral Runout

NOTE: Excessive lateral runout will cause rotor wobble resulting in chatter, vibration and pedal pulsation.

- (2) Measure rotor thickness variation (fig. 2G-59).

- (a) Measure variation using micrometer or two dial indicators.
- (b) Take readings at four or more equally spaced points around rotor circumference and one inch (25 mm) inward from outer edge of rotor.
- (c) Thickness variation, from point-to-point, must not vary by more than limit stated in Rotor Specifications.
- (d) Refinish rotor if thickness variation exceeds stated limit. Replace rotor if machining will not correct variation or if machining would cause rotor to fall below minimum thickness specification.

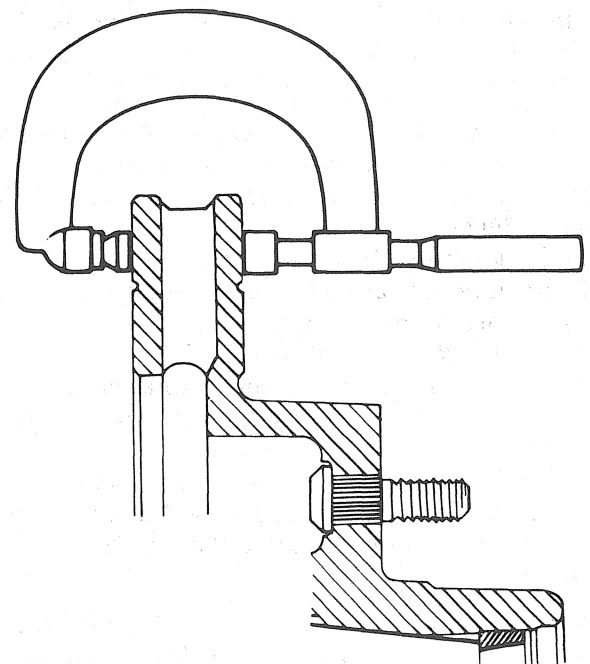

42890

Fig. 2G-59 Checking Thickness Variation

NOTE: Excessive thickness variation will cause pedal pulsation and vibration when the brakes are applied.

Rotor Refinishing

Rotor refinishing should only be performed using equipment that will machine both of the rotor surfaces simultaneously (machining one side at a time can produce a tapered rotor). The correct surface finish is 15 to 80 microinches for CJ models; 20 to 60 microinches for Cherokee, Wagoneer and Truck models and must not have tool marks (grooves) after machining (fig. 2G-60).

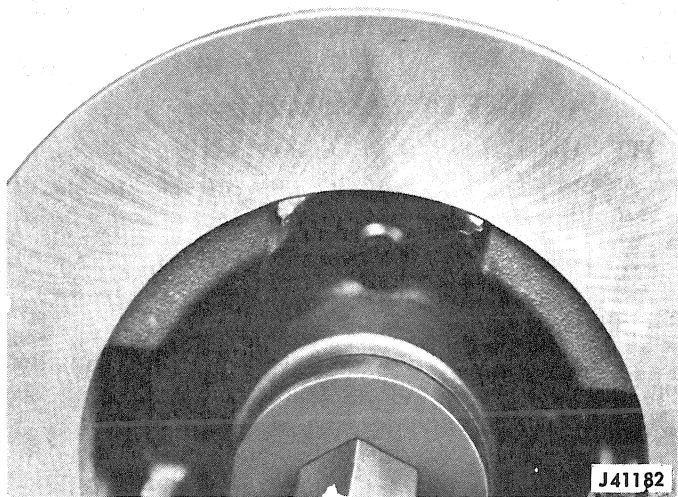

Fig. 2G-60 Correct Rotor Finish (Nondirectional Crosshatch Pattern)

NOTE: If a rotor is glazed or highly polished, sanding the rotor may not produce the required rotor finish. It may be necessary to turn the rotor to meet the finish requirements.

To ensure a correct surface finish, follow the lathe manufacturer's recommendations for feed and speed and either sharpen or replace dull cutting tool bits before machining rotor.

- (1) Remove rotor from steering spindle.
- (2) Remove bearings and seal from rotor and clean bearing surfaces in rotor hub thoroughly.
- (3) Mount rotor in lathe according to manufacturer's instructions and install anti-chatter band.
- (4) Sharpen or replace cutting tool bits as necessary.
- (5) Machine rotor as necessary and according to lathe manufacturer's instructions only. Make two cuts if required and do not remove more than 0.007 inch (0.18 mm) at a time.

CAUTION: Do not attempt to refinish the rotor if machining would cause the part to fall below the minimum (replacement) thickness specification for that rotor. Refer to the Specifications section.

NOTE: If one disc brake assembly requires a new set of brakeshoes, the shoes on the other assembly must also be replaced to ensure even braking.

Rotor Replacement—CJ Models

Removal

- (1) Raise and support vehicle.
- (2) Remove wheel.
- (3) Remove caliper. Refer to Brakeshoe Replacement—CJ Models.
- (4) Remove bolts attaching hub body to hub clutch and remove hub body.
- (5) Remove retaining ring from axle shaft and remove hub clutch and bearing assembly.
- (6) Straighten lip of outer locknut retaining washer.
- (7) Remove outer locknut and retaining washer and remove inner locknut and retaining washer.
- (8) Remove hub and rotor.
- (9) Remove wheel bearings from rotor.

Installation

- (1) Lubricate wheel bearings with EP-type, waterproof wheel bearing lubricant.
- (2) Install wheel bearings and replacement grease seal in rotor.
- (3) Install rotor.
- (4) Install tabbed inner washer and inner locknut.
- (5) Install wheel but do not tighten wheel nuts completely.
- (6) Tighten inner locknut to 50 foot-pounds (68 N•m) torque using tool J-25103. Rotate wheel while tightening locknut to seat bearings uniformly.
- (7) Back off inner locknut 1/6 turn (45°-65°).
- (8) Install outer tabbed washer and outer locknut. Tighten outer locknut to minimum of 50 foot-pounds (68 N•m) torque and bend lip of tabbed washer over locknut.
- (9) Install hub clutch and bearing assembly on axle shaft.
- (10) Install retaining ring on axle shaft.
- (11) Install new gasket on hub body and install body on clutch and bearing assembly.
- (12) Align bolt holes in hub body and rotor hub and install hub attaching bolts and tabbed lockwashers. Tighten bolts to 30 foot-pounds (41 N•m) torque.
- (13) Install caliper. Refer to Brakeshoe Replacement—CJ Models.
- (14) Lower vehicle.

Rotor Replacement—Cherokee-Wagoneer-Truck Models

Removal

- (1) Remove wheel cover, if equipped, and loosen wheel retaining nuts.

- (2) Raise vehicle.
- (3) Remove wheels.
- (4) Remove caliper. Refer to Brakeshoe Replacement—Cherokee-Wagoneer-Truck Models.
- (5) On models without front hubs:
 - (a) Remove rotor hub cap.
 - (b) Remove drive gear snap ring and remove drive gear, pressure spring, and spring cup.
- (6) On models with front hubs:
 - (a) Remove socket head screws attaching hub body to hub clutch and remove hub body from clutch.
 - (b) Remove large and small hub retaining rings.
 - (c) Remove hub clutch from axle shaft.
- (7) Straighten lip of outer locknut retaining washer.
- (8) Remove wheel bearing outer and inner locknuts and retaining washers using tool J-6893.
- (9) Remove rotor.
- (10) Remove wheel bearings from rotor.

Installation

- (1) Lubricate wheel bearings with EP-type, water-proof wheel bearing lubricant.
- (2) Install wheel bearings and replacement grease seal in rotor.
- (3) Install rotor.
- (4) Install inner locknut using tool J-6893.

NOTE: *The bearing adjuster inner locknut has a locating peg on one side. When installed, this peg must face away from the bearing.*

- (5) Install wheel on rotor but do not tighten wheel nuts completely at this time.
- (6) Tighten inner locknut to 50 foot-pounds (68 N•m) torque using tool J-6893. Rotate wheel while tightening locknut to seat bearings uniformly.
- (7) Back off inner locknut 1/6 turn (45°-65°) while rotating wheel.

- (8) Install retaining washer and outer locknut.

NOTE: *Be sure the inner locknut locating peg is engaged in one of the retaining washer holes before installing the outer locknut.*

- (9) Tighten outer locknut to minimum of 50 foot-pounds torque (68 N•m) using tool J-6893.
- (10) On models without front hub:
 - (a) Install pressure spring cup.

CAUTION: *The spring cup must be installed so the recessed side of the cup faces the outboard bearing and the flat side of the cup faces the pressure spring.*

- (b) Install pressure spring, drive gear and snap ring.
- (c) Coat rim of chrome hub cap with Permatex Form-A-Gasket number 3 (or equivalent) and install cap in rotor hub.
- (11) On models with front hubs:
 - (a) Install hub clutch on axle.
 - (b) Install large and small hub retaining rings.
 - (c) Install hub body on clutch and install socket head screws. Tighten screws to 30 inch-pounds (3 N•m) torque.
- (12) Remove wheel and install caliper. Refer to Brakeshoe Replacement—Cherokee-Wagonner-Truck models.
- (13) Reinstall wheel but do not tighten wheel nuts completely.
- (14) Lower vehicle.
- (15) Tighten wheel nuts to 75 foot-pounds (102 N•m) torque on Cherokee, Wagoneer and Truck. On 8400 GVW J-20 Truck, tighten nuts to 130 foot-pounds (176 N•m) torque.
- (16) Install wheel cover, if equipped.

SPECIFICATIONS

General Specifications

Caliper Piston Diameter:

CJ Models	2.6 inches (6.60 cm)
Cherokee-Wagoneer-Truck	2.94 inches (7.45 cm)

Minimum Rotor Thickness:

CJ Models	.815 inches (20.7 mm)
Cherokee-Wagoneer-Truck	1.215 inches (30.86 mm)

Rotor Diameter:

CJ Models	11.7 inches (29.7 cm)
Cherokee-Wagoneer-J10 Truck	12.0 inches (30.48 cm)
J-20 Truck	12.5 inches (31.75 cm)

Rotor Hub-To-Bore Runout Limit 0.010 inches (0.25 mm)

Rotor Lateral Runout Limit 0.005 inches (0.12 mm)

Rotor Thickness Variation 0.001 inches (0.02 mm)

Torque Specifications

Service Set-To Torques should be used when assembling components. Service In-Use Recheck Torques should be used for checking a pre-torqued item.

	USA (ft-lbs)		Metric (N-m)	
	Service Set-To Torque	Service In-Use Recheck Torque	Service Set-To Torque	Service In-Use Recheck Torque
Caliper Mounting Bolts (Cke-Wag-Trk)	35	30-40	47	41-54
Caliper Support Key Retaining Screw (CJ)	15	15-18	20	20-24
Caliper Brake Line Fitting	160 in-lbs.	150-170 in-lbs.	18	17-19
Disc Brake Shield Bolts (Cke-Wag-Trk)	8	5-10	11	7-14
Disc Brake Shield Nuts (Cke-Wag-Trk)	35	30-40	47	41-54
Front Wheel Bearing Adjusting Locknuts	50	50-55	68	68-75
Wheel Retaining Lugnuts:				
CJ Models	75	65-80	102	88-108
Cherokee—Wagoneer—J-10 Truck	75	65-80	102	88-108
J-20 Truck (8400 GVW)	130	110-150	176	149-203

All torque values given in foot-pounds and newton-meters with dry fits unless otherwise specified.

80396

Tools

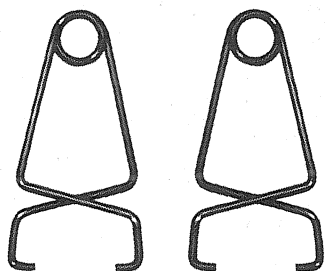

J-8002
WHEEL CYLINDER CLAMPS

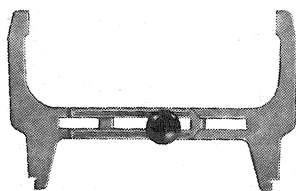

J-21177
DRUM BRAKE
CLEARANCE GAUGE

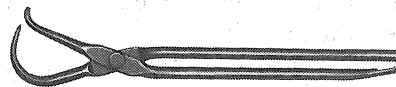

J-8057
BRAKE SPRING TOOL



J-23709
METERING VALVE TOOL
(TYPE-D VALVE)

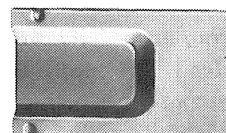

J-26869
METERING VALVE TOOL
(TYPE-W VALVE)

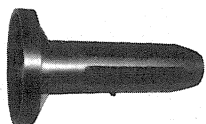

J-22904
DUST BOOT INSTALLER

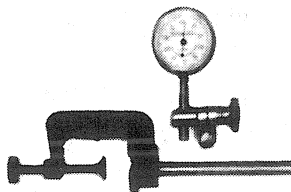

J-8001
DIAL INDICATOR SET

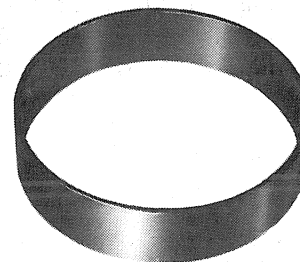

J-24837
CALIPER PISTON
INSTALLER

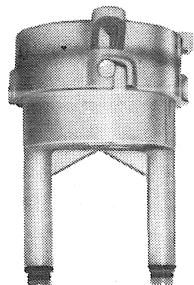

J-26819-24
BRAKE BLEEDER
ADAPTER

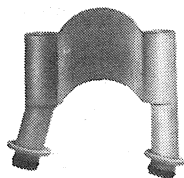

J-26819-30
BRAKE BLEEDER
EXTENSION



J-26819-25
BLEEDER ADAPTER
CLAMP

80397